

BR/EDR Radio Physical Layer (RF)

Bluetooth® Test Suite

- **Revision:** RF.TS.p37
- **Revision Date:** 2026-05-05
- **Prepared By:** BTI
- **Published during TCRL:** TCRL.pkg103



This document, regardless of its title or content, is not a Bluetooth Specification as defined in the Bluetooth Patent/Copyright License Agreement (“PCLA”) and Bluetooth Trademark License Agreement. Use of this document by members of Bluetooth SIG is governed by the membership and other related agreements between Bluetooth SIG Inc. (“Bluetooth SIG”) and its members, including the PCLA and other agreements posted on Bluetooth SIG’s website located at www.bluetooth.com.

THIS DOCUMENT IS PROVIDED “AS IS” AND BLUETOOTH SIG, ITS MEMBERS, AND THEIR AFFILIATES MAKE NO REPRESENTATIONS OR WARRANTIES AND DISCLAIM ALL WARRANTIES, EXPRESS OR IMPLIED, INCLUDING ANY WARRANTY OF MERCHANTABILITY, TITLE, NON-INFRINGEMENT, FITNESS FOR ANY PARTICULAR PURPOSE, THAT THE CONTENT OF THIS DOCUMENT IS FREE OF ERRORS.

TO THE EXTENT NOT PROHIBITED BY LAW, BLUETOOTH SIG, ITS MEMBERS, AND THEIR AFFILIATES DISCLAIM ALL LIABILITY ARISING OUT OF OR RELATING TO USE OF THIS DOCUMENT AND ANY INFORMATION CONTAINED IN THIS DOCUMENT, INCLUDING LOST REVENUE, PROFITS, DATA OR PROGRAMS, OR BUSINESS INTERRUPTION, OR FOR SPECIAL, INDIRECT, CONSEQUENTIAL, INCIDENTAL OR PUNITIVE DAMAGES, HOWEVER CAUSED AND REGARDLESS OF THE THEORY OF LIABILITY, AND EVEN IF BLUETOOTH SIG, ITS MEMBERS, OR THEIR AFFILIATES HAVE BEEN ADVISED OF THE POSSIBILITY OF SUCH DAMAGES.

This document is proprietary to Bluetooth SIG. This document may contain or cover subject matter that is intellectual property of Bluetooth SIG and its members. The furnishing of this document does not grant any license to any intellectual property of Bluetooth SIG or its members.

This document is subject to change without notice.

Copyright © 2003–2026 by Bluetooth SIG, Inc. The Bluetooth word mark and logos are owned by Bluetooth SIG, Inc. Other third-party brands and names are the property of their respective owners.



Contents

1	Scope	5
2	References, definitions, and abbreviations	6
2.1	References	6
2.2	Definitions	6
2.3	Acronyms and abbreviations	6
3	Test Suite Structure (TSS)	7
3.1	Test Strategy	7
3.2	Test groups	8
3.2.1	Protocol groups	8
3.2.2	Main test groups	8
4	Test cases (TC)	9
4.1	Introduction	9
4.1.1	Test case identification conventions	9
4.1.2	Conformance	9
4.2	Common test case conditions	10
4.3	Pass/Fail verdict conventions	10
4.4	Common Packet Contents	10
4.4.1	Fields and Bits Reserved for Future Use	10
4.5	Transmitter	10
	RF/TRM/CA/BV-01-C [Output Power]	10
	RF/TRM/CA/BV-02-C [Power Density]	11
	RF/TRM/CA/BV-03-C [Power Control]	13
	RF/TRM/CA/BV-04-C [TX Output Spectrum – Frequency Range]	14
	RF/TRM/CA/BV-06-C [TX Output Spectrum – Adjacent Channel Power]	16
	RF/TRM/CA/BV-07-C [Modulation Characteristics]	17
	RF/TRM/CA/BV-08-C [Initial Carrier Frequency Tolerance]	19
	RF/TRM/CA/BV-09-C [Carrier Frequency Drift]	20
	RF/TRM/CA/BV-10-C [EDR Relative Transmit Power]	22
	RF/TRM/CA/BV-11-C [EDR Carrier Frequency Stability and Modulation Accuracy]	23
	RF/TRM/CA/BV-12-C [EDR Differential Phase Encoding]	26
	RF/TRM/CA/BV-13-C [EDR In-band Spurious Emissions]	27
	RF/TRM/CA/BV-14-C [Enhanced Power Control]	29
	RF/TRM/CA/BV-15-C [EDR Guard Time]	31
	RF/TRM/CA/BV-16-C [EDR Synchronization Sequence and Trailer]	34
4.6	Receiver	35
4.6.1	Packet sensitivity	35
	RF/RCV/CA/BV-01-C [Sensitivity - single slot packets]	35
	RF/RCV/CA/BV-02-C [Sensitivity - multi-slot packets]	35
	RF/RCV/CA/BV-03-C [C/I Performance]	37
	RF/RCV/CA/BV-04-C [Blocking Performance]	39
	RF/RCV/CA/BV-05-C [Intermodulation Performance]	40
	RF/RCV/CA/BV-06-C [Maximum Input Level]	41
4.6.2	Sensitivity bit error rate	43
	RF/RCV/CA/BV-07-C [EDR Sensitivity]	43
	RF/RCV/CA/BV-08-C [EDR BER Floor Performance]	43
	RF/RCV/CA/BV-09-C [EDR C/I Performance]	45
	RF/RCV/CA/BV-10-C [EDR Maximum Input Level]	47



5	Test case mapping	48
6	Annex	49
6.1	Reference Signal Definition	49
6.1.1	2 Mbps Reference Signal (EDR)	50
6.1.2	3 Mbps Reference Signal (EDR)	50
6.2	Frequencies for testing	50
6.2.1	Operating frequency bands	50
6.2.2	Frequencies for testing, loopback, hopping off	51
6.2.3	Frequencies for testing, TX-Test, hopping off	51
6.3	Normal test conditions	51
6.3.1	Normal temperature and humidity	51
6.3.2	Nominal Power source	52
6.4	Bit error rate (BER) measurements	52
6.5	Definition of the position of Bit p0	53
6.6	Definition of the reference sensitivity level	53
6.7	Antenna gain	53
6.8	Measurement Uncertainty	53
6.8.1	Conducted measurements:	53
6.8.2	Relative RF power	53
6.8.3	Radiated measurements	53
6.8.4	Absolute radio frequency	54
6.8.5	Relative drift radio frequency	54
6.8.6	Peak frequency deviation	54
7	Revision history and acknowledgments	55

1 Scope

This Bluetooth document contains the Test Suite Structure (TSS) and test cases to test the implementation of the Bluetooth RF layer, including Enhanced Data Rate, with the objective to provide a high probability of air interface interoperability between the tested implementation and other manufacturers' Bluetooth devices.

2 References, definitions, and abbreviations

2.1 References

This document incorporates provisions from other publications by dated or undated reference. These references are cited at the appropriate places in the text, and the publications are listed hereinafter. Additional definitions and abbreviations can be found in [1] and [2].

- [1] Specification of the Bluetooth System, Version 2.1 + EDR or later, Core System Package, Volume 2, Part A
- [2] Test Strategy and Terminology Overview
- [3] ICS Proforma for BR/EDR Radio Physical Layer (RF)
- [4] ETS 300 328: "Electromagnetic compatibility and Radio spectrum Matters (ERM); Wideband transmission systems; Data transmission equipment operating in the 2,4 GHz ISM band and single wide band modulation techniques; Harmonized EN covering the essential requirements of article 3.2 of the R&TTE Directive v 1.9.1 (2015-02)"
- [5] FCC Part 15: CFR 47, Part 15 "Radio Frequency Device", Sections 15.205, 15.209, 15.247
- [6] Specification of the Bluetooth System, Core System Package, Volume 2, Part B, Baseband (BB)
- [7] IXIT Proforma for Bluetooth Conformance Test Suites
- [8] Specification of the Bluetooth System, Version 5.4 or later, Core System Package, Volume 2, Part A

2.2 Definitions

In this Bluetooth document, the definitions from [1] and [2] apply.

2.3 Acronyms and abbreviations

In this Bluetooth document, the definitions, acronyms, and abbreviations from [1] and [2] apply.

3 Test Suite Structure (TSS)

3.1 Test Strategy

The Bluetooth RF is layer 1 of the Bluetooth protocol stack.

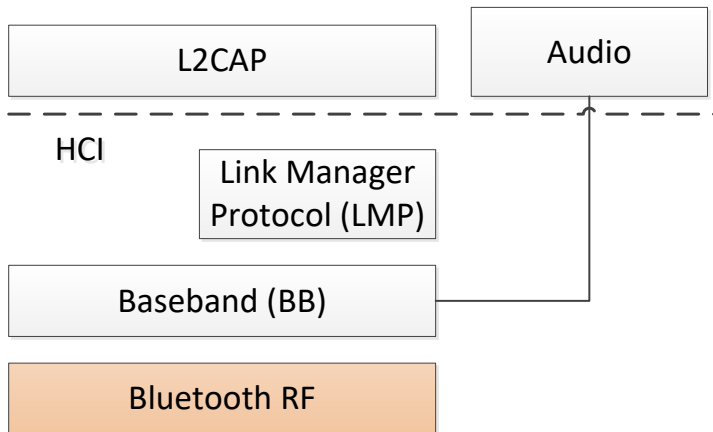

Figure 3.1: Bluetooth protocol stack, Basic Layers

Bluetooth RF Test Suite Structure

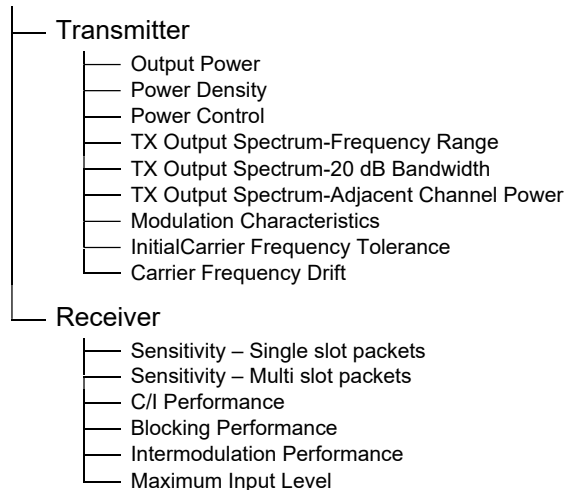

Figure 3.2: Test Suite Structure for Bluetooth RF

Bluetooth EDR RF Test Suite Structure

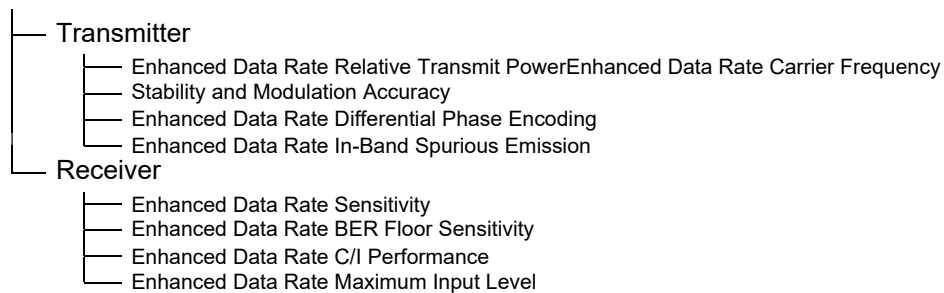

Figure 3.3: Test Suite Structure for Bluetooth EDR RF

3.2 Test groups

The test groups are organized in three levels. The first level defines the protocol groups representing the protocol services. The second level separates the protocol services in functional modules. The last level in each branch contains the standard ISO subgroups BV and BI (not shown in [Figure 3.3](#)).

3.2.1 Protocol groups

The protocol group identifies the kind of test for Bluetooth RF test purposes:

- Transmitter
- Receiver

3.2.2 Main test groups

The main test groups are the capability group, the valid behavior group and the invalid behavior group.

3.2.2.1 Capability (CA) tests

This subgroup provides testing of the major IUT capabilities aiming to ensure that the claimed capabilities are correctly supported, according to the ICS.

3.2.2.2 Valid Behavior (BV) tests

This subgroup provides testing to verify that the IUT reacts in conformity with the Bluetooth standard, after receipt or exchange of a valid Protocol Data Units (PDUs). Valid PDUs means that the exchange of messages and the content of the exchanged messages are considered as valid.

3.2.2.3 Invalid Behavior (BI) tests

This subgroup provides testing to verify that the IUT reacts in conformity with the Bluetooth standard, after receipt of a syntactically or semantically invalid PDU.

4 Test cases (TC)

4.1 Introduction

4.1.1 Test case identification conventions

Test cases are assigned unique identifiers per the conventions in [2]. The convention used here is: **<spec abbreviation>/<IUT role>/<class>/<feat>/<func>/<subfunc>/<cap>/<xx>-<nn>-<y>**.

Identifier Abbreviation	Spec Identifier <spec abbreviation>
RF	Radio
Identifier Abbreviation	Feature Identifier <feat>
RCV	Receiver Tests
TRM	Transmitter Tests

Table 4.1: RF TC feature naming conventions

4.1.2 Conformance

When conformance is claimed for a particular specification, all capabilities are to be supported in the specified manner. The mandated tests from this Test Suite depend on the capabilities to which conformance is claimed.

The Bluetooth Qualification Program may employ tests to verify implementation robustness. The level of implementation robustness that is verified varies from one specification to another and may be revised for cause based on interoperability issues found in the market.

Such tests may verify:

- That claimed capabilities may be used in any order and any number of repetitions not excluded by the specification
- That capabilities enabled by the implementations are sustained over durations expected by the use case
- That the implementation gracefully handles any quantity of data expected by the use case
- That in cases where more than one valid interpretation of the specification exists, the implementation complies with at least one interpretation and gracefully handles other interpretations
- That the implementation is immune to attempted security exploits

A single execution of each of the required tests is required to constitute a Pass verdict. However, it is noted that to provide a foundation for interoperability, it is necessary that a qualified implementation consistently and repeatedly pass any of the applicable tests.

In any case, where a member finds an issue with the test plan generated by the Bluetooth SIG qualification tool, with the test case as described in the Test Suite, or with the test system utilized, the member is required to notify the responsible party via an erratum request such that the issue may be addressed.

4.2 Common test case conditions

Unless stated otherwise in individual test cases the following applies throughout this Test Suite:

1. The IUT is connected to the tester via a 50Ω connector. If there is no antenna interface, a temporary 50Ω interface or a suitable coupling device may be used.
2. The test case is to be performed at normal operating conditions.

4.3 Pass/Fail verdict conventions

Each test case has an Expected Outcome section. The IUT is granted the Pass verdict when all the detailed pass criteria conditions within the Expected Outcome section are met.

The convention in this Test Suite is that, unless there is a specific set of fail conditions outlined in the test case, the IUT fails the test case as soon as one of the pass criteria conditions cannot be met. If this occurs, then the outcome of the test is a Fail verdict.

4.4 Common Packet Contents

4.4.1 Fields and Bits Reserved for Future Use

Unless a specific test states otherwise, all fields within packets and all bits within fields that are described as reserved for future use are set to 0 in packets sent by the Upper and Lower Testers.

4.5 Transmitter

RF/TRM/CA/BV-01-C [Output Power]

- Test Purpose

Verification of the maximum average RF output power.

- Reference

[1] 3

- Initial Condition

- IUT in test mode loop back or TX mode.
- IUT hopping on or off.
- The IUT transmits to the Lower Tester at maximum supported output power.
- TSPX_Antenna_Gain is declared by the manufacturer of the IUT in the IXIT [7].

- Test Procedure

The test is run using the supported modulation mode that has the highest output power.

- a) Tester transmits longest supported packet in the chosen modulation mode, with full payload with PRBS9 as payload to the IUT. (See Section 6.1 “Reference Signal Definition”.)
- b) If Hopping is off, IUT transmits at lowest operating TX frequency.
- c) The spectrum analyzer settings are as follows:
 - Center frequency: the lowest operating frequency
 - Span: Zero Span
 - Resolution Bandwidth: 3 MHz



- Video Bandwidth: 3 MHz
 - Detector: Peak
 - Mode: Clear/Write
 - Sweeptime: depending on packet type (one complete packet)
 - Trigger: extern (to signaling unit.)
- d) Tester calculates average power P_{AV} over at least 20% to 80% of the duration of the burst (position of p0 defines the begin of the burst)
or
 if the measuring system is not able to determine the p0 bit in the burst:
 Tester calculates average power P_{AV} over at least 20% to 80% of the duration of the burst. (The duration of the burst is the time between the leading and trailing 3 dB points compared to the average power).
- e) Repeat b)–d) while the analyzer center frequency is set to:
 the mid operating frequency; and the highest operating frequency.
- These frequencies are defined in Section 6.2.2, “Frequencies for testing, loopback, hopping off.”
- NOTE: When using test equipment that can follow the hopping sequence the low, mid, and upper frequencies can be tested when hopped to.
- f) The TSPX_Antenna_Gain (in dBi) is added to the results (in dBm) measured in part a)–e) to calculate average equivalent isotropic radiated power $P_{AV\ EIRP}$.
- Test Condition
 Common Test Case Conditions defined in Section 4.2 apply.
 - Expected Outcome
Pass verdict
 All values as measured fulfill the following conditions.
 $P_{AV\ EIRP} < 100\ \text{mW}$ (20 dBm) EIRP
 If the IUT is a power class 1 equipment:
 - $P_{AV} > 2.5\ \text{mW}$ (4 dBm)
 If the IUT is not a power class 1 equipment:
 - $P_{AV} \leq 2.5\ \text{mW}$ (4 dBm)
 - Notes
 If the test is performed using loopback mode, then it is recommended that the payload content is checked as well.

RF/TRM/CA/BV-02-C [Power Density]

- Test Purpose
 Verification of the maximum RF-output power density.
- Reference
[\[4\]](#)



- Initial Condition
 - IUT in test mode loop back or TX mode.
 - Hopping on.
 - The IUT transmits to the Lower Tester at maximum supported output power.
- Test Procedure

The test is run using the supported modulation mode that has the highest output power.

 - a) Tester transmits longest supported packet in the chosen modulation mode, with full payload with PRBS9 as payload to the IUT. (See Section 6.1 “Reference Signal Definition”.)
 - b) The spectrum analyzer settings are as follows:
 - Center frequency: 2441 MHz
 - Span: ≥ 80 MHz
 - Resolution Bandwidth: 100 kHz
 - Video Bandwidth: 100 kHz
 - Detector: Peak
 - Mode: Maxhold
 - Sweeptime: 1 sec per 100 kHz span
 - Trigger: freerun.

If the measurement equipment is not able to store one sample for each 100 kHz frequency range, the span may be split for several measurements.
 - c) A trace is done and the peak value of the trace is found.
 - d) The spectrum analyzer is set to Zero Span, the center frequency is set to the frequency found in Step c), and the sweep time is set to 1 minute. A single sweep is running.
 - e) The power density is calculated as the peak value of the trace captured in Step d).
 - f) The antenna gain G (in dBi) is added to the results (in dBm) measured in part a)–e).
- Test Condition

Common Test Case Conditions defined in Section 4.2 apply.
- Expected Outcome

Pass verdict

All values as measured fulfill the following conditions.

Power Density < 100 mW (20dBm) per 100 kHz EIRP.
- Notes

If the test is performed using loopback mode, then it is recommended that the payload content is checked as well.

RF/TRM/CA/BV-03-C [Power Control]

- Test Purpose

Verification of the TX power control.
- Reference

[1] 3
- Initial Condition
 - The IUT is in test mode loop back or TX mode.
 - Hopping is off.
 - The IUT transmits to the Lower Tester at maximum supported output power.
 - TSPX_Timer_TX_Power_Control is declared by the manufacturer of the IUT in the IXIT [7].
- Test Procedure
 - a) The tester sets the IUT to the lowest operating TX frequency using LMP commands.

Repeat Steps b)–d) for each supported modulation mode. In Step d), P_{AV} is stored for each modulation mode and output power in each repeat.
 - b) The tester transmits the longest supported packet in the modulation mode being tested, with full payload with PRBS9 as payload to the IUT. (See Section 6.1 “Reference Signal Definition”.)
 - c) The spectrum analyzer settings are as follows:
 - Center frequency: the lowest operating frequency
 - Span: Zero Span
 - Resolution Bandwidth: 3 MHz
 - Video Bandwidth: 3 MHz
 - Detector: Peak
 - Mode: Clear/Write
 - Sweptime: one complete DH1 packet
 - Trigger: extern (to signaling unit)
 - d) The tester calculates average power P_{AV} over at least 20%–80% of the duration of the burst (position of p0 defines the begin of the burst)

or

if the measuring system is not able to determine the p0 bit in the burst:
The tester calculates average power P_{AV} over at least 20%–80% of the duration of the burst. (The duration of the burst is the time between the leading and trailing 3 dB points compared to the average power).
 - e) Decrease the IUT output power for one power step.

The next measurement starts after the IUT has reached the new power step (TSPX_Timer_TX_Power_Control, default value = 1 second, see Section 5).

Record the measurement for each supported modulation.
 - f) Repeat Steps b)–f) until the minimum possible output power step of the IUT is reached.

- g) The tester increases IUT's output power one step using an LMP command. Repeat Steps b)–e). Step size is recorded by the tester.
- h) Repeat Step g) to the maximum possible output power setting of the IUT.
- i) Repeat Steps b)–h) while the IUT receives (f_{RX}) / loops back (FTX) at: the mid operating frequency and the highest operating frequency.
- j) These frequencies are defined Section 6.2.2, "Frequencies for testing, loopback, hopping off".

- Test Condition

Common Test Case Conditions defined in Section 4.2 apply.

- Expected Outcome

Pass verdict

All values as measured fulfill the following conditions.

Expected Outcome refers to the step size and to the minimum output power. The latter depends on the power class of the IUT.

Step size of the power control: $2\text{dB} \leq \text{step size} \leq 8\text{ dB}$ for each supported modulation mode

For power class 1 equipment:

- At minimum power step: $P_{AV} < 4\text{dBm}$ for each supported modulation mode

When the power level is increased or decreased, P_{AV} for each supported modulation mode changes in the same direction, and the power levels of the supported modulation modes remain within 10 dB of each other.

- Notes

If the test is performed using loopback mode, then it is recommended that the payload content is checked as well.

RF/TRM/CA/BV-04-C [TX Output Spectrum – Frequency Range]

- Test Purpose

Verification that the emissions inside the operating frequency range are within the limits.

- Reference

[1] 3

- Initial Condition

- IUT in test mode loop back or TX mode.
- Hopping off.
- IUT transmits to the Lower Tester at maximum supported output power.

- Test Procedure

The test is run using the supported modulation mode that has the highest output power.

- a) IUT is set to lowest TX frequency.
- b) Tester transmits longest supported packet in the chosen modulation mode, with full payload with PRBS9 as payload to the IUT. (See Section 6.1 "Reference Signal Definition".)



- c) The spectrum analyzer settings are set as follows:
- Resolution bandwidth (RBW): 100 kHz
 - Video bandwidth: 300 kHz
 - Center frequency: lowest supported TX frequency
 - Start frequency: see [Table 4.1](#)
 - Stop frequency: see [Table 4.1](#)
 - Detector: Peak
 - Mode: averaging
 - Sweep time: 2s (at least one burst per sample)
 - Trigger: extern (to signaling unit)
 - Number of sweeps: 50.

TX channel	Start frequency/MHz	Stop frequency/MHz
Lowest	2399	2405
Highest	2475	2485

Table 4.1: Start and Stop Frequency

- d) Find lowest frequency below the operating frequencies at which spectral power density drops below the level of -80 dBm/Hz e.i.r.p (-30 dBm if measured in a 100 kHz bandwidth). This frequency is called fL. It is recorded in the test report.
- e) Set IUT to transmit on highest TX frequency.
- f) Set spectrum analyzer center frequency to highest TX frequency. The other spectrum analyzer settings are as in Step c).
- g) Find highest frequency above the operating frequencies at which spectral power density drops below the level of -80 dBm/Hz e.i.r.p (-30 dBm if measured in a 100 kHz bandwidth). This frequency is called fH. It is recorded in the test report.
- IUT Test Condition
Common Test Case Conditions defined in Section [4.2](#) apply.
 - Expected Outcome
Pass verdict
All values as measured fulfill the following conditions.
fL, fH within the allowed frequency band:
2.4 GHz – 2.4835 GHz
 - Notes
If the test is performed using loopback mode it is recommended that the payload content is checked as well.

RF/TRM/CA/BV-06-C [TX Output Spectrum – Adjacent Channel Power]

- Test Purpose

Verification that the emissions inside the operating frequency range are within the limits.

- Reference

[1] 3.1.2.1

- Initial Condition

- IUT in test mode loop back.
- Hopping off.
- IUT transmits to the Lower Tester at maximum supported output power.

- Test Procedure

The test is run using GFSK.

The transmit frequency is defined by the index M (transmit frequency $f(M)$ is calculated according to Section 6.2, “Frequencies for testing” substituting M for k). In the same way, the measurement frequency is defined by the index N.

- IUT is set to transmit on ($f_{TX} = f(3)$) ($M = 3$)
- Set $N := 0$.
- Tester transmits longest supported GFSK packet, with full payload with PRBS9 as payload to the IUT (see Section 6.1, Reference Signal Definition).
- The Spectrum Analyzer is set as follows:
 - Span: Zero Span
 - Center frequency: $f(N) - 450$ kHz
 - Resolution bandwidth: 100 kHz
 - Video bandwidth: 300 kHz
 - Detector: Average
 - Mode: maxhold
 - Sweep time: 100 ms
 - Number of sweeps: 10
- Determine maximum value P_{TXn} of the trace.
- Increase center frequency for 100 kHz.
- Repeat Steps e)–f) until center frequency = $f(N) + 450$ kHz.
- Calculate $P_{TX}(f) = \sum(P_{TXi}), i = 1 \dots 10$.
- Increase center frequency by 1 MHz: $N := N+1$ AND skip to next frequency if the increased frequency equals to f_{TX} or " $f_{TX} - 1$ MHz" or " $f_{TX} + 1$ MHz".
- Repeat Steps c)–i) until $f(N)$ is above the maximum TX frequency.



- k) Set the IUT transmit frequency (f_{TX}) to:
- The mid operating frequency; and
 - The frequency $f(M_{max} - 3)$ where $f(M_{max})$ corresponds to the highest operating frequency.

These frequencies (mid, high) and the related RX frequencies for polling are defined in Section 6.2.2, “Frequencies for testing, loopback, hopping off”.

l) Set $N := 0$.

m) Repeat Steps c)–j).

- Test Condition

Common Test Case Conditions defined in Section 4.2 apply.

- Expected Outcome

Pass verdict

All values as measured fulfill the following conditions.

The IUT is transmitting on channel M and the adjacent channel power is measured on channel number N. N is chosen to cover the whole regulatory range, see Section 6.2.1, “Operating frequency bands”.

$$P_{TX}(f) \leq -20 \text{ dBm for } |M-N| = 2$$

$$P_{TX}(f) \leq -30 \text{ dBm for } |M-N| \geq 3$$

For each operating frequency M, exceptions in up to three bands are allowed where $|M-N| \geq 3$. For exceptions, $P_{tx}(f) \leq -20 \text{ dBm}$.

- Notes

If the test is performed using loopback mode, then it is recommended that the payload content is checked as well.

RF/TRM/CA/BV-07-C [Modulation Characteristics]

- Test Purpose

Verification of the modulation index.

- Reference

[1] 3.1.1

- Initial Condition

- IUT in test mode loop back with whitening turned off or TX mode.
- Hopping off.
- IUT transmits to the Lower Tester at maximum supported output power.

- Test Procedure

The test is run using GFSK.

a) IUT transmits (f_{TX}) at: lowest operating frequency



- b) Tester transmits longest supported GFSK packet with full payload with 11110000...-Bit pattern as payload.

The measurement bandwidth of the tester is at least 1.3 MHz. Passband ripple to ± 550 kHz: is a maximum of 0.5 dB (peak to peak)

It is recommended that the test equipment should use a measurement filter with the following specification:

Transition band minimum attenuations:

- ± 650 kHz: -3 dB
 - ± 1 MHz: -14 dB
 - ± 2 MHz: -44 dB
- c) Tester determines the position of bit p0 (see Section 6.5, "Definition of the position of Bit p0") in the packets looped back by the IUT. This is the timing reference to identify the bits in the payload field.
- d) Tester calculates for each "00001111" 8 bit sequence in the payload the average frequency over the frequency values of the 8 bits. To determine the correct deviation value of each bit it is oversampled at least four times. Then take the average over these at least four samples as the deviation for each bit. For each second, third, sixth and seventh of the 8 bits the deviation from the average frequency within the bit period is recorded as $\Delta f1_{max}$.
- e) The average of all the $\Delta f1_{max}$ deviation values measured before is calculated, and recorded as $\Delta f1_{avg}$.
- f) Tester transmits longest supported DM or DH packet with full payload (1, 3 or 5 slot) with 101010...-Bit pattern as payload.
- g) Tester determines the position of bit p0 (see Section 6.5, "Definition of the position of Bit p0") in the packets looped back by the IUT. This is the timing reference to identify the bits in the payload field.
- h) Starting with the second payload bit, the STE calculates for each "01010101" 8 bit sequence in the payload the average frequency over these 8 bits. For each of the 8 bits the maximum deviation from this average within the bit period is recorded as $\Delta f2_{max}$.
- i) The average of all the maximum deviation values measured before is calculated, and recorded as $\Delta f2_{avg}$.
- j) Repeat Steps b)–i) for at least 10 packets.
- k) Repeat Steps b)–j) while the IUT transmits (f_{TX}) at:
- The mid operating frequency; and
 - The highest operating frequency.

These frequencies and the related RX frequencies are defined in Section 6.2.2, "Frequencies for testing, loopback, hopping off".

- Test Condition

Common Test Case Conditions defined in Section 4.2 apply.



- Expected Outcome

Pass verdict

All values as measured fulfill the following conditions.

The average of all frequency deviations $\Delta f_{1\text{avg}}$, as measured, is within 140 kHz and 175 kHz.

At least 99.9% of all frequency deviations $\Delta f_{2\text{max}}$, as measured, are greater than 115 kHz.

The ratio of all frequency deviations $\Delta f_{2\text{avg}}$, as measured, and $\Delta f_{1\text{avg}}$ does not lie below 80%.

$$140 \text{ kHz} \leq \Delta f_{1\text{avg}} \leq 175 \text{ kHz}$$

$$\Delta f_{2\text{max}} \geq 115 \text{ kHz for at least 99.9\% of all } \Delta f_{2\text{max}}$$

$$\frac{\Delta f_{2\text{avg}}}{\Delta f_{1\text{avg}}} \geq 0.8$$

- Notes

Whitening is disabled while the test case is performed.

Alternatively, it is allowed to use TX mode instead of loop back mode for sending the 1010. bit pattern and 1111000 ... bit pattern, if possible.

The figure of 99.9% was used to compensate the influence of the statistical distribution of the measured values as each single value is considered in the verdict.

If the test is performed using loopback mode, then it is recommended that the payload content is checked as well.

It is allowed for the tester to change the order of the test sequence in loopback and TX test mode. The tester can send and measure packets with either payload in any order.

RF/TRM/CA/BV-08-C [Initial Carrier Frequency Tolerance]

- Test Purpose

Verification of the transmitter carrier frequency accuracy

- Reference

[1] 3.1.3

- Initial Condition

- IUT in test mode loop back or TX mode.
- Hopping off.
- IUT transmits to the Lower Tester at maximum supported output power,

- Test Procedure

The test is run using GFSK.

- a) IUT transmits DH1 packets with PRBS9 as payload to the tester.
- b) Tester measures packets received at the lowest operating frequency. The measurement bandwidth of the tester is at least 1.3MHz. Passband ripple to $\pm 550\text{kHz}$: is a maximum of 0.5 dB (peak to peak)

It is recommended that the test equipment should use a measurement filter with the following specification:

Transition band minimum attenuations:

- ± 650 kHz: -3 dB
 - ± 1 MHz: -14 dB
 - ± 2 MHz: -44dB
- c) Tester determines the position of bit p0 (see Section 6.5, “Definition of the position of Bit p0”) in the packets looped back by the IUT. This is the timing reference to identify the bits in the payload field.
- d) The tester makes an integration of the packet’s 4 preamble bits and the first bit after the 4th preamble bit on the IUT’s f_{TX} channel. The measurement starts at the center of the first preamble bit until the center of the first bit following the 4th preamble bit.
- e) The IUT’s carrier frequency is assumed to be the result of this integration done in d) and is named f_0 .
- f) Repeat Steps b)–e) for at least 10 packets.
- g) Repeat Steps c)–f) with packets measured:
- The mid operating frequency; and
 - The highest operating frequency.

These frequencies can be found in Section 6.2.2.

- Test Condition

Common Test Case Conditions defined in Section 4.2 apply.

- Expected Outcome

Pass verdict

All values as measured fulfill the following conditions.

Each of the IUT’s carrier frequency f_0 as measured is within ± 75 kHz from the IUT’s chosen nominal carrier frequency f_{TX} .

$$f_{TX} - 75 \text{ kHz} \leq f_0 \leq f_{TX} + 75 \text{ kHz}.$$

RF/TRM/CA/BV-09-C [Carrier Frequency Drift]

- Test Purpose

Verification of the transmitter center frequency drift within a packet.

- Reference

[1] 3.1.3

- Initial Condition

- IUT in loop back mode with whitening turned off or TX mode.
- Hopping off.
- IUT transmits to the Lower Tester at maximum supported output power.



- Test Procedure
 - a) IUT transmits packets with a 1010-sequence as payload. All supported packets (DH1/3/5) with the longest supported payload length are used.
 - b) Tester measures packets received at the lowest operating frequency. The measurement bandwidth of the tester is at least 1.3MHz. Passband ripple to $\pm 550\text{KHz}$: is a maximum of 0.5 dB (peak to peak)

It is recommended that the test equipment should use a measurement filter with the following specification:

Transition band minimum attenuations:

$\pm 650\text{ kHz}$: -3 dB

$\pm 1\text{ MHz}$: -14 dB

$\pm 2\text{ MHz}$: -44dB

- c) Tester determines the position of bit p0 (see Section 6.5, “Definition of the position of Bit p0”) in the packets looped back by the IUT. This is the timing reference to identify the bits in the payload field.
- d) The tester makes an integration of the packet’s 4 preamble bits and the first bit after the 4th preamble bit on the IUT’s f_{TX} channel. The measurement starts at the center of the first preamble bit until the center of the first bit following the 4th preamble bit. The IUT’s carrier frequency is assumed to be the result of this integration and is named f_0 .
- e) Tester integrates the frequency deviations of every 10 bit symbols in the payload body (k-th measurement leads to f_k). The measurement starts with the 2nd payload bit, so that the first 10 bit block includes payload bit 2-11.
- f) Repeat Steps b)–e) for at least 10 packets.
- g) Repeat Steps b)–f) for all supported packet lengths (DH1/3/5 packets).
- h) Repeat Steps c)–g) with packets measured at:
 - Mid operating frequency; and
 - Highest operating frequency.

These frequencies can be found in Section 6.2.2, “Frequencies for testing, loopback, hopping off”.

- Test Condition

Common Test Case Conditions defined in Section 4.2 apply.

- Expected Outcome

Pass verdict

All values as measured fulfill the following conditions.

The transmitter center frequency is not allowed to drift more than the limits given in [Table 4.2](#).

Type of Packet	Frequency Drift
One slot packet	± 25 kHz
Three slot packet	± 40 kHz
Five slot packet	± 40 kHz

Table 4.2: Frequency Drift within a packet

The frequency drift limits apply to the difference between the average frequency of the 4 preamble bits f_0 and the average frequency of any 10 bits in the payload field of the returned packets f_k .

The maximum drift rate applies to the difference between any two 10-bit groups separated by 50 μ s within the payload field of the returned packets.

$$|f_{k+5} - f_k| \leq 20000 \text{ Hz, } k=1 \dots \text{max.}$$

RF/TRM/CA/BV-10-C [EDR Relative Transmit Power]

- Test Purpose

Verification of the acceptable range for the difference in average transmit power during frequency modulated [GFSK] and phase modulated [DPSK] portions of a packet.

- Reference

[1] 3.2.4

- Initial Condition

- IUT in test mode loop back or TX mode, with whitening off.
- Hopping off (transmit and receive frequencies are defined in [Section 6.2.2](#)).
- The IUT transmits to the Lower Tester at maximum supported output power.

- Test Procedure

- IUT transmits longest supported $\pi/4$ -DQPSK packet type (2-DHx or 2-EVx) with maximum length payload containing PRBS9.
- IUT transmits at lowest operating TX frequency.
- The spectrum analyzer is set as follows:
 - Center frequency: IUT transmit frequency
 - Span: Zero Span
 - Resolution Bandwidth: 3 MHz



- Video Bandwidth: 3 MHz
 - Detector: Average (Sample may also be used)
 - Mode: Clear Write (continuous update)
 - Sweeptime: depending on packet type (one complete packet)
 - Trace Average: 10
- d) Tester calculates average power PGFSK over at least 80% of the GFSK portion (Access Code & Header period) of the packet.
- e) Tester calculates the average power PDPSK over at least 80% of the DPSK portion of the packet (Synchronization sequence and payload).
- f) Repeat Steps d)–f) while the IUT transmits at:
- The mid operating frequency; and
 - The highest operating frequency.
- g) If power control is supported, repeat Steps c)–f) with IUT transmitting minimum output power. If the IUT does not support power control, continue to Step h).
- h) If 8DPSK modulation is supported by the IUT, repeat Steps b)–h) while the IUT transmits longest supported 8DPSK packet type (3-DHx or 3-EVx) with maximum length payload containing PRBS9.
- Test Conditions

Common Test Case Conditions defined in Section 4.2 apply.
 - Expected Outcome

Pass verdict

For all pairs of results: (PGFSK – 4dB) < PDPSK < (PGFSK + 1dB)

RF/TRM/CA/BV-11-C [EDR Carrier Frequency Stability and Modulation Accuracy]

- Test Purpose

Verification of the transmitter carrier frequency stability and modulation accuracy.
- Reference

[1] 3.2.1.4, 3.2.3
- Initial Condition
 - IUT in test mode loop back or TX mode, with whitening off.
 - Hopping off (transmit and receive frequencies are defined in Section 6.2.2).
 - IUT transmits to the Lower Tester at maximum supported output power.
- Test Procedure
 - a) IUT transmits the longest supported $\pi/4$ -DQPSK packet type (2-DH1, 2-DH3, 2-DH5, 2-EV3, or 2-EV5). The user payload bytes contain PRBS9 pseudo-random data. The number of user payload bytes is 31 for 2-DH1 packets, 58 for 2-EV3 packets, 356 for 2-DH3 packets, 358 for 2-EV5 packets or 656 for 2-DH5 packets.
 - b) IUT transmits at the lowest operating frequency.



- c) Tester calculates the initial center frequency error for a packet transmitted by the IUT using the following method applied to the basic rate portion of the packet:
- Tester determines the start time of the first preamble bit p_0 using the measurement method.
 - Tester calculates the frequency deviations at the bit centers (referenced to p_0) of the packet header bits, relative to the ideal carrier frequency.
 - Tester selects those bits from the header that have the same value as both the previous and following bits so are not significantly affected by inter-symbol interference (there will be at least 18 bits of this type). The tester may also select other bits from the header, but the frequency deviations of these bits are compensated to remove inter-symbol interference.
 - Tester calculates the average frequency deviation $\Delta\omega_1$ of those selected packet header bits that represent a transmitted '1'.
 - Tester calculates the average frequency deviation $\Delta\omega_2$ of those selected packet header bits that represent a transmitted '0'.
 - Tester calculates the initial frequency error $\omega_i = (\Delta\omega_1 + \Delta\omega_2)/2$.
- d) Tester compensates the Enhanced Data Rate portion of the packet for the initial frequency error ω_i of the packet.
- e) Tester applies a square-root raised cosine measurement filter with a roll-off factor of 0.4 and a 3 dB bandwidth of ± 500 kHz to the Enhanced Data Rate portion of the packet.
- f) Tester partitions the output of the measurement filter into non-overlapping blocks of 50 μ secs beginning at the nominal start of the synchronization symbol following the reference symbol and finishing at the nominal end of the final payload CRC symbol (the number of user payload bytes has been chosen to make this an integral number of blocks).
- g) For each block, tester calculates the sampling phase ϵ_0 and frequency error ω_0 for the RMS DEVM for the block, as defined Appendix C of the Enhanced Data Rate RF Specification (note that this computation includes information from the symbol immediately before the block to generate the 50 differential error vectors). The frequency error ω_0 and the RMS DEVM for each block are recorded.
- h) For each block, tester calculates the DEVM for each symbol in the block using the sampling phase ϵ_0 and frequency error ω_0 for the block as calculated in Step g). The DEVM for each symbol is recorded.
- i) Repeat Steps c)–h) for further packets transmitted by the IUT until a total of 200 blocks have been measured (any remaining blocks from the end of the final packet should be discarded).
- j) Repeat Steps b)–i) while the IUT transmits at:
- The mid operating frequency; and
 - The highest operating frequency.
- k) If 8DPSK modulation is supported by the IUT, repeat Steps b)–j) using the longest supported 8DPSK packet type (3-DH1, 3-DH3, 3-DH5, 3-EV3, or 3-EV5). The user payload bytes contain PRBS9 pseudo-random data. The number of user payload bytes is 11 for 3-DH1 packets, 88 for 3-EV3 packets, 536 for 3-DH3 packets, 538 bytes for 3-EV5 packets or 986 for 3-DH5 packets.

- Test Condition

Common Test Case Conditions defined in Section 4.2 apply.

- Expected Outcome

Pass verdict

If the IUT does not support 8DPSK modulation then the outcomes based on this modulation do not apply.

All values as measured fulfill the following conditions:

1. Carrier frequency stability:

-75 kHz < ω_i < +75 kHz, for all packets

-75 kHz < ($\omega_i + \omega_0$) < +75 kHz, for all blocks

-10 kHz < ω_0 < +10 kHz, for all blocks

2. RMS DEVM:

RMS DEVM \leq 0.20, for all $\pi/4$ -DQPSK blocks

RMS DEVM \leq 0.13, for all 8DPSK blocks

3. Peak DEVM:

DEVM \leq 0.35 for all $\pi/4$ -DQPSK symbols

DEVM \leq 0.25 for all 8DPSK symbols

4. 99% DEVM:

DEVM \leq 0.30, for 99% of $\pi/4$ -DQPSK symbols

DEVM \leq 0.20, for 99% of 8DPSK symbols

- Notes

The tester checks that the correct packet type (for loop back and TX test modes) and payload (for loop back test mode only) have been transmitted by the IUT; any invalid packets should be discarded to avoid corruption of the measurements.

For measurements based on basic rate symbols:

- The requirements on the measurement bandwidth of the tester are the same as used in TRM/CA/BV-07-C Modulation Characteristics.
- The method for measuring the position of bit p0 in the basic rate signal is that same as used in TRM/CA/BV-07-C Modulation Characteristics.
- The minimum sampling rate for the basic rate portion of the packet is 8 samples per bit period to obtain a sufficiently accurate estimate of the initial frequency error (interpolation may be used to obtain this sampling rate from a lower initial sampling rate).
- It is recommended that the tester uses combinations of UAP and AM_ADDR values that result in non-whitened packet headers with at least five 1's and at least five 0's (including the HEC, but prior to FEC) to ensure a good estimate of initial carrier frequency.

For measurements based on Enhanced Data Rate symbols:

- The number of user payload bytes has been chosen to be as close as possible to the maximum packet size, subject to the constraint that the synchronization symbols, the two payload header bytes (for n-DHx packets), the user payload and the two CRC bytes constitute an integer number

of DEVM blocks. This ensures that the modulation accuracy of all symbols, other than the trailer symbols, is measured.

- The PRBS9 pseudo random generator is initialized with a seed of all ones at the beginning of each test packet. The first PRBS9 output bit represents the least significant bit of the first user payload byte.
- The definition of the square-root raised cosine measurement filter is given in [RF Spec]. The measurement filter frequency response is accurate of ± 0.25 dB up to 0.65 MHz from the carrier frequency and provides at least 40 dB suppression for frequencies more than 0.8 MHz from the carrier frequency. The measurement filter requirement is referenced to the connector on the IUT, so includes the contributions due to all aspects of the signal processing applied by the tester.
- The tester gives an RMS DEVM of less than 3% and a Peak DEVM of less than 8% when a test signal from a reference signal generator is applied and the defined test procedure is followed. This requirement is met when the test signal has any frequency error up to ± 75 kHz and any symbol rate error up to ± 20 ppm.

RF/TRM/CA/BV-12-C [EDR Differential Phase Encoding]

- Test Purpose

Verification that the modulator correctly differential phase encodes the data.

- Reference

[1] 3.2.1.2

- Initial Condition

- IUT in TX mode with whitening turned off.
- Hopping off (transmit and receive frequencies are defined in Section 6.2.2).
- IUT transmits to the Lower Tester at maximum supported output power.

- Test Procedure

- a) IUT transmits 2-DH1 or 2-EV3 packets to the tester with maximum length payload containing PRBS9.
- b) IUT transmits at lowest operating frequency.
- c) Tester demodulates 100 packets and compares each payload with the expected PRBS9 data.
- d) If 8DPSK modulation is supported by the IUT repeat Steps b)–c) using 3-DH1 or 3-EV3 packets with maximum length payload containing PRBS9.

- Test Condition

Common Test Case Conditions defined in Section 4.2 apply.

- Expected Outcome

Pass verdict

The expected outcome of this test is zero errors detected by the tester in 99% of the packets.

- Notes

The PRBS9 pseudo random generator is initialized with a seed of all ones at the beginning of each test packet. The first PRBS9 output bit represents the least significant bit of the first user payload byte.

RF/TRM/CA/BV-13-C [EDR In-band Spurious Emissions]

- Test Purpose

Verification that the level of unwanted signals from the DPSK transmitter, within the frequency range used by the device, is below the required level.

- Reference

[1] 3.2.2.1

- Initial Condition

- IUT in test mode loop back or TX mode, with whitening off.
- Hopping off (transmit and receive frequencies are defined in Section 6.2.2).
- IUT transmits to the Lower Tester at maximum supported output power.

- Test Procedure

The transmit frequency is defined by the index M (transmit frequency $f(M)$ is calculated according to Section 6.2, (substituting M for k). In the same way the measurement frequency is defined by the index N. N is chosen to cover the whole regulatory range, see Section 6.2.1.

- Tester transmits longest supported $\pi/4$ -DQPSK packet type (2-DHx or 2-EVx) with maximum length payload containing PRBS9.
- IUT is set to transmit on $f_{TX} = f(3)$ ($M = 3$)
- Set $N := 0$
- The Spectrum Analyzer is set as follows:
 - Span: Zero Span
 - Center frequency: $f(N) - 450$ kHz
 - Resolution bandwidth: 100 kHz
 - Video bandwidth: 300 kHz
 - Detector: Average
 - Mode: maxhold
 - Sweep time: 100 ms
 - Number of sweeps: 10
- If $|M-N| > 1$,
 - Set center frequency to $f(N) - 450$ kHz and set $n := 1$
 - Determine maximum value PTX_n of the trace
 - Increase center frequency by 100 kHz and set $n := n+1$

- iv) Repeat Steps ii) and iii) until center frequency $> f(N) + 450\text{kHz}$
 - v) Calculate $\text{PTX}(f) = \sum(\text{PTX}_i), i = 1 \dots 10$
 - f) If $(M-N) = +1$,
 - i) Set center frequency to $f(N) - 450\text{kHz}$ and set $n := 1$
 - ii) Determine maximum value PTX_n of the trace
 - iii) Increase center frequency by 100 kHz and set $n := n+1$
 - iv) Repeat Steps ii) and iii) until center frequency $> f(N) - 50\text{kHz}$
 - v) Calculate $\text{PTX} - 26\text{dB}(f) = \text{Sum}(\text{PTX}_i)/5, i = 1 \dots 5$
 - g) If $(M-N) = 0$,
 - i) Set center frequency to $f(N) - 450\text{kHz}$ and set $n := 1$
 - ii) Determine maximum value PTX_n of the trace
 - iii) Increase center frequency by 100 kHz and set $n := n+1$
 - iv) Repeat Steps ii) and iii) until center frequency $> f(N) + 450\text{kHz}$
 - v) Calculate $\text{PTX}_{\text{ref}}(f) = \max(\text{PTX}_i), i = 1 \dots 10$
 - h) If $(M-N) = -1$,
 - i) Set center frequency to $f(N) + 50\text{kHz}$ and set $n := 1$
 - ii) Determine maximum value PTX_n of the trace
 - iii) Increase center frequency by 100 kHz and set $n := n+1$
 - iv) Repeat Steps ii) and iii) until center frequency $> f(N) + 450\text{kHz}$
 - v) Calculate $\text{PTX} - 26\text{dB}(f) = \text{Sum}(\text{PTX}_i)/5, i = 1 \dots 5$
 - i) Set $N := N+1$
 - j) Repeat Steps d)–h) until $f(N)$ is above the maximum TX frequency.
 - k) Repeat Steps c)–i) with the IUT transmit frequency (f_{TX}) set to:
 - The mid operating frequency; and
 - The frequency $f(M_{\text{max}}-3)$, where $f(M_{\text{max}})$ is the highest operating frequency.
 - These frequencies and the related receive frequencies are defined in Section 6.2.2.
 - l) If 8DPSK modulation is supported by the IUT, repeat Steps b)–j) while the IUT transmits longest supported 8DPSK packet type (3-DHx or 3-EVx) with maximum length payload containing PRBS9.
- Test Conditions
 - Common Test Case Conditions defined in Section 4.2 apply.

- Expected Outcome

Pass verdict

All values as measured fulfill the following conditions.

- $PTX_{-26dB}(f) \leq PTX_{ref} - 26 \text{ dB}$ for $|M-N| = 1$
- $PTX(f) \leq -20 \text{ dBm}$ for $|M-N| = 2$
- $PTX(f) \leq -30 \text{ dBm}$ for $|M-N| \geq 3$

For each operating frequency M, exceptions in up to three bands are allowed where $|M - N| \geq 3$. For exceptions, $Ptx(f) \leq -20 \text{ dBm}$.

- Notes

This test is similar to TRM/CA/BV-06-C except here the measurement is gated to cover only the DPSK portion of the packet.

RF/TRM/CA/BV-14-C [Enhanced Power Control]

- Test Purpose

Verification of the TX Enhanced power control.

- Reference

[1] 3

- Initial Condition

- IUT in test mode loop back or TX mode may be used, whitening off.
- Hopping off.
- The tester puts the IUT at maximum output power using the LMP_POWER_CONTROL_REQ PDU with the power adjustment_req set to "go to max."

- Test Procedure

- Tester sets IUT to lowest operating TX frequency using LMP commands.
- Tester transmits DH1 packets with PRBS9 as payload to the IUT. (See Section 6.1, "Reference Signal Definition").
- The spectrum analyzer settings are as follows:
 - Center frequency: the lowest operating frequency
 - Span: Zero Span
 - Resolution Bandwidth: 3 MHz
 - Video Bandwidth: 3 MHz
 - Detector: Peak
 - Mode: Clear/Write
 - Sweeptime: one complete packet as selected under Step b)
 - Trigger: extern (to signaling unit)
- Tester calculates average power PAV over at least 20% - 80% of the duration of GFSK header of the burst (position of p0 defines the beginning of the burst).

- e) Repeat Steps b)–e) for the IUT transmitting 2-DH1 and 3-DH1 packet types (EDR packets) if they are supported.
- f) Tester uses the power change request LMP command to decrease the IUT output power for one power step.

The next measurement starts after the Tester has received the power change response for the power change request from the IUT.

- g) Repeat Steps b)–g) until minimum output power of the IUT is indicated by the Power change response for all supported modulations.

The power step size of each modulation, if the response indicates a power change for the modulation, and the difference between the GFSK header of the different modulations, are recorded for each step.

- h) Tester uses the power change request LMP command to increase the IUT output power one step.

The next measurement starts after the Tester has received the power change response for the power change request from the IUT.

- i) Repeat Steps b)–f) and i) until the maximum output power of the IUT is indicated by the Power change response for all modulations supported.

The power step size of each modulation, if the response indicates a power change for the modulation, and the difference between the GFSK header of the different modulations, are recorded for each step.

- j) Repeat Steps b)–j) while the IUT transmits (f_{TX}) / loops back $(f_{RX} - f_{TX})$ at: the mid operating frequency; and the highest operating frequency.

These frequencies are defined in Section 6.2.2, “Frequencies for testing, loopback, hopping off”.

- Test Condition

Common Test Case Conditions defined in Section 4.2 apply.

- Expected Outcome

Pass verdict

All values as measured fulfill the following conditions.

Expected outcome depends on the power class of the IUT.

- Step size for the enhanced power control requests for all supported modulations $2\text{dB} \leq \text{step size} \leq 8\text{ dB}$.
- The power differences between GFSK headers of the supported modulations at every stage within 10dB ($\leq 10\text{dB}$).
- For power class 1 equipment: At minimum power step of all supported modulations: $P_{AV} \leq 4\text{dBm}$.
- The Maximum power level for each of the supported modulations measured in stage e) at the start of the test is within $\pm 3\text{dB}$ of the power measured at the end of the test sequence when the IUT has reported maximum power for each of the supported modulations.

- Notes

If the test is performed using loopback mode, then it is recommended that the payload content is checked as well.



RF/TRM/CA/BV-15-C [EDR Guard Time]

- Test Purpose

Verify the duration of the guard time between the basic rate packet header and the Enhanced Data Rate synchronization sequence.
- Reference

[6] 6.6.1
- Initial Condition
 - IUT in test mode loop back or TX mode (or manual configuration if loopback is not available), whitening off.
 - Hopping off.
 - IUT transmits at maximum output power back to the Lower Tester.
- Test Procedure
 - a) IUT transmits maximum length 2-DH1 or 2-EV3 packets containing PRBS9.
 - b) Lower Tester demodulates a packet.
 - c) Lower Tester determines the start time of the first preamble bit p0 using the measurement method defined in Section 6.6 of the Radio Frequency Test Suite [5].
 - d) Lower Tester determines the start time of the reference symbol of the Enhanced Data Rate portion of the packet from the Enhanced Data Rate synchronization sequence. The start time of the reference symbol is defined as 1 μ s before the time when the symbol following the reference symbol becomes the dominant contributor to the transmitter's instantaneous phase. The required method of determining the start time of the reference symbol is provided in the Notes section.
 - e) Lower Tester determines the guard time, that is the time difference between the end of the last header symbol (defined as 126 microseconds after p0) and the start of the reference symbol of the Enhanced Data Rate portion, referenced to the output of the IUT transmitter.
 - f) Repeat Steps b)–e) for 100 packets
 - g) If Enhanced Data Rate 3 Mbps payload data rate is supported by the IUT, repeat Steps b)–f) using maximum length 3-DH1 or 3-EV3 packets containing PRBS9 data.
- Test Condition

Common Test Case Conditions defined in Section 4.2 apply.
- Expected Outcome

Pass verdict

95% of the measured guard times of the packets must fall within the range $4.75 - \varepsilon \mu\text{s} < \text{guard time} < 5.25 + \varepsilon \mu\text{s}$, where $\varepsilon = 0.15 \mu\text{s}$ is the allowed uncertainty due to the measurement process.
- Notes

The Lower Tester should use all the symbols in the synchronization sequence to determine the timing of the reference symbol.

Background of Method of Measurement

The method of determining the start time of the reference symbol is based on the following observation.

According to Section 3.2.1.3 of [5], the lowpass equivalent information bearing signal $v(t)$ is given by:

$$v(t) = \sum_k S_k p(t - kT)$$

Symbol K becomes the dominant contributor to the transmitter phase when:

$$p(t - KT) > \left(\sum_k p(t - kT) \right) - p(t - KT)$$

$$2p(t - KT) > v(t)$$

The instantaneous frequency of the signal will be:

$$f = fc + \frac{d}{dt} \tan^{-1} \left(\frac{\text{imag}(v(t))}{\text{real}(v(t))} \right)$$

It can be shown that:

$$2p(t - KT) = vt \Rightarrow \frac{df}{dt} = 0$$

At the point where symbol K becomes the dominant contributor then the instantaneous frequency will have an extreme value.

The position of the start of the reference symbol, s_0 , is calculated using an averaging based on the position of all the frequency extremes in the sync word.

Required Measurement Method

The required method of measuring the start of the reference symbol and thus the guard time is defined below.

Set the test equipment to vector analyzer mode and turn on FM demodulation with symbol rate 1 MHz. Trigger by any means to achieve reliable viewing of the guard period. Look for and identify the synchronization sequence. The start of the reference symbol is defined to be one micro-second preceding the first frequency extreme of the synchronization sequence.

For the 10 frequency extreme values in the sync word, the i 'th frequency extreme value time is $t(i)$ in μsec , this is the start of symbol i .

$$1 \leq i \leq 10$$

The start of symbol s_0 is then

$$t_0 = \frac{1}{10} \sum_{i=1}^{10} (t(i) - i \times \text{symbol time})$$

where symbol time is 1 μsec .



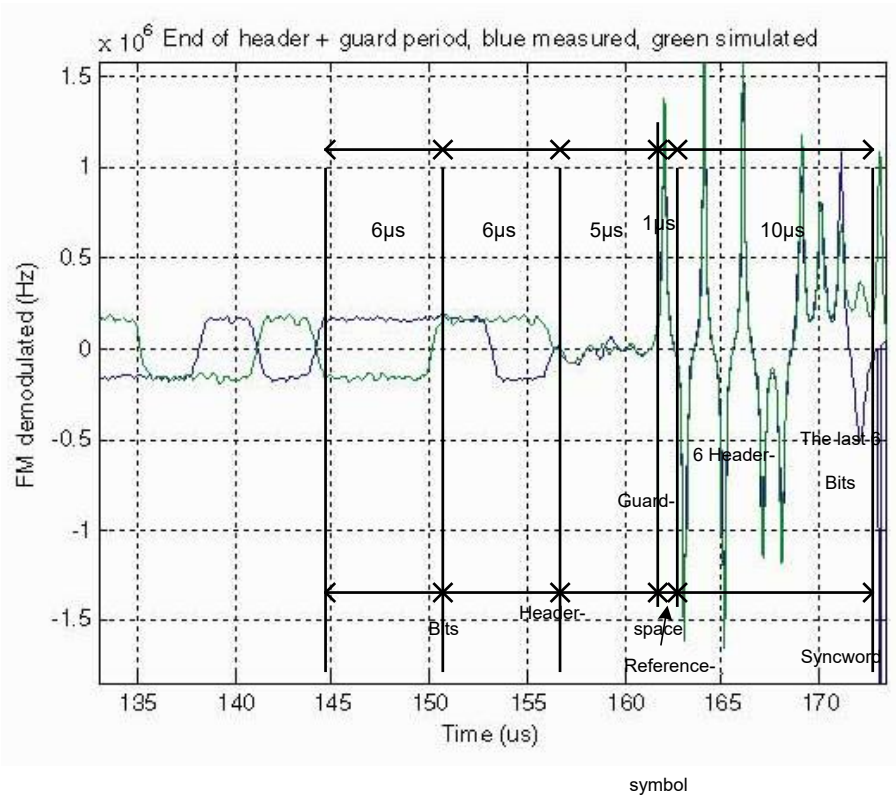

Figure 4.1: Instantaneous Frequency of Signal about the Guard Time

Instantaneous Frequency of Signal about the Guard Time is a plot of how the instantaneous frequency will look during the last bits of the header and the EDR sync word:

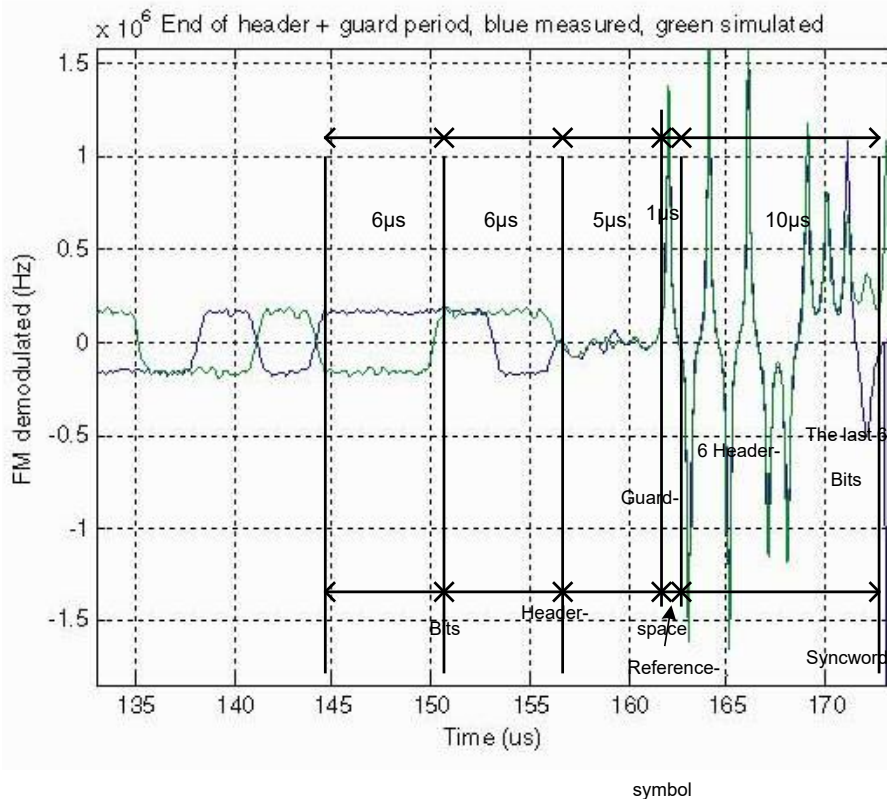

Figure 4.2: Instantaneous Frequency of Signal about the Guard Time

RF/TRM/CA/BV-16-C [EDR Synchronization Sequence and Trailer]

- Test Purpose

Verify the synchronization sequence and trailer symbols that are transmitted in Enhanced Data Rate packets.

- Reference

[6] 6.6.1

- Initial Condition

- IUT in test mode loop back or TX mode (or manual configuration if loopback is not available), whitening off.
- Hopping off.
- IUT transmits at maximum output power back to the Lower Tester.

- Test Procedure

- IUT transmits maximum length 2-DH1 or 2-EV3 packets containing PRBS9 data.
- Lower Tester demodulates a packet, including the synchronization sequence and the two trailer symbols.
- Lower Tester compares the demodulated bits corresponding to the synchronization sequence with the correct bit sequence defined in [1] and compares the demodulated trailer bits with zeros.

- d) Repeat Steps b)–c) for 50 packets.
- e) If Enhanced Data Rate 3 Mbps payload data rate is supported by the IUT, repeat Steps b)–d) with maximum length 3-DH1 or 3-EV3 packets containing PRBS9 data.

- Test Condition

Common Test Case Conditions defined in Section 4.2 apply.

- Expected Outcome

Pass verdict

For each modulation, the Expected Outcome over all 50 tested packets is zero bit errors in the synchronization sequences and no more than one bit error in all the trailer symbols.

4.6 Receiver

4.6.1 Packet sensitivity

Test	Packet	Packet type	Synchronized sine wave frequency modulation	Frequency modulation
RF/RCV/CA/BV-01-C [Sensitivity - single slot packets]	Single slot	DH1	± 25 kHz	1.6kHz
RF/RCV/CA/BV-02-C [Sensitivity - multi-slot packets]	Multi slot	DH5 or DH3 if DH5 is not supported	± 40 kHz	500 Hz for 3 slot packets 300 Hz for 5 slot packets

Table 4.3: Packet sensitivity tests

Set of parameters	Carrier frequency offset	Modulation index	Symbol time period error
1	75 kHz	0.28	- 20 ppm
2	14 kHz	0.30	- 20 ppm
3	- 2 kHz	0.29	+ 20 ppm
4	1 kHz	0.32	+ 20 ppm
5	39 kHz	0.33	+ 20 ppm
6	0 kHz	0.34	- 20 ppm
7	-42 kHz	0.29	- 20 ppm
8	74 kHz	0.31	- 20 ppm

Set of parameters	Carrier frequency offset	Modulation index	Symbol time period error
9	-19 kHz	0.28	- 20 ppm
10	-75 kHz	0.35	+ 20 ppm

Table 4.4: Dirty transmitter packets

- Test Purpose

The sensitivity is tested using a non-ideal transmitter. These test cases define the signal sent to the IUT in detail. The IUT is to meet the required sensitivity for this non-ideal signal.

- Reference

[1] 4.1.1

- Initial Condition

- IUT in test mode. Loop back.
- Hopping off.
- IUT transmits at maximum output power back to the tester.
- The tester's transmit power is chosen such that the input power to the IUT receiver is – 70 dBm.

- Test Procedure

When multiple power classes are declared in the ICS, the test is performed using the power class representing the highest power supported.

1. IUT receives (f_{RX})/loops back (f_{TX}) at:
 - the lowest operating frequency.
2. The tester continuously sends the packet type specified in Table 4.3 to the IUT. The Payload is PRBS9.
3. The properties of the packets are chosen according to Table 4.4. Beside those parameters, the reference signal settings of Section 6.1, "Reference Signal Definition" have to be used. The tester transmits the first 20 ms using the first parameter set (see Table 4.4). The second 20 ms are transmitted with parameter set 2 and so forth. After the 10th set of parameters has been used, the tester continues using the first set again.
4. The returned packets are received and the BER is measured by the tester according to Section 6.4 "Bit error rate (BER) measurements" (minimum number of samples, 1 600 000 returned payload bits.)
5. Repeat Steps 2–4 while the IUT receives (f_{RX}) /loops back (f_{TX}) at:
 - the mid operating frequency; and
 - the highest operating frequency.

These frequencies and the related RX frequencies are defined in Section 6.2.2, "Frequencies for testing, loopback, hopping off".

Additionally, to the described dirty transmitter signal parameters in Table 4.4, a synchronized sine wave frequency modulation (alternate packets will switch start phase between 0 and 180 degrees)

and a modulation frequency defined in [Table 4.3](#) is to be modulated on the signal to realize the carrier frequency drift.

- Test Condition

Common Test Case Conditions defined in [Section 4.2](#) apply.

- Expected Outcome

Pass verdict

All values as measured are to fulfill the following conditions.

$BER \leq 0.1\%$ (minimum number of samples, 1 600 000 returned payload bits).

- Uncertainties

It is fixed if the measurement equipment can support a dirty transmitter as specified in this test case.

- Notes

If suitable test equipment is available this test case should be done with hopping on.

RF/RCV/CA/BV-03-C [C/I Performance]

- Test Purpose

Verification of the receiver's performance in presence of co-/adjacent channel interference.

- Reference

[1] 4.1.1

- Initial Condition

- IUT in test mode loop back.
- Hopping off.
- IUT transmits at maximum output power back to the tester.
- TSPX_Inband_Image_Frequency is declared by the manufacturer of the IUT in the IXIT [7].

- Test Procedure

When multiple power classes are declared in the ICS, the test is performed using the power class representing the highest power supported.

- IUT receives (f_{RX}) / loops back (f_{TX}) at low operating frequency (see [Table 4.5](#)).
- Tester transmits at the same time:
 - Wanted signal (Reference Bluetooth signal, see [Section 6.1](#), "Reference Signal Definition"): DH1 packet with PRBS9 as payload for interfering signal on Co-channel: -67 dBm.
 - Bluetooth modulated interfering signal with PRBS15 as payload (see [Section 4.9](#) "Reference Signal Definition"). This interfering signal is operating at $f_1 = f_{RX}$. For the interference power level see [Table 4.6](#).
- The returned packets are received and the BER is measured by the tester according to [Section 6.4](#) "Bit error rate (BER) measurements" (minimum number of samples, 1 600 000 returned payload bits).

- d) Repeat Steps b)–c) for all frequencies $f_i + k$ MHz, that are regular Bluetooth transmit frequencies.
- e) Repeat Steps b)–d) for the wanted signal at the frequencies (Mid operating frequency, high operating frequency) that are specified in [Table 4.5](#).

Low operating frequency		Mid operating frequency		High operating frequency	
IUT fRX	IUT fTX	IUT fRX	IUT fTX	IUT fRX	IUT fTX
2405 MHz	2405 MHz	2441 MHz	2441 MHz	2477 MHz	2477 MHz

Table 4.5: Low, Mid, and High Operating Frequency

Interferer Frequency	Ratio
Co-Channel interference, C/I co-channel	11 dB
Adjacent (1 MHz) interference ^{Note 1} , C/I _{1MHz}	0 dB
Adjacent (2 MHz) interference ^{Note 1} , C/I _{2MHz}	-17 dB
Adjacent (≥ 3 MHz) interference ^{Note 1} , C/I _{≥ 3MHz}	-27 dB
Image frequency Interference ^{Notes 1, 2, 3} , C/I _{Image}	-9 dB
Adjacent (1 MHz) interference to in-band mirror frequency ^{Notes 1, 2, 3} , C/I _{Image\pm1MHz}	-15 dB

Table 4.6: Interferer and wanted signal settings

Note 1: If two adjacent channel specifications from [Table 4.6](#) are applicable to the same channel, the more relaxed specification applies.

Note 2: If the image frequency $\neq n*1$ MHz, then the image reference frequency is defined as closest $n*1$ MHz frequency.

Note 3: TSPX_Inband_Image_Frequency

- Test Condition

Common Test Case Conditions defined in [Section 4.2](#) apply.

- Expected Outcome

Pass verdict

All values as measured fulfill the following conditions.

$$\text{BER} \leq 0.1 \%$$

Frequencies where the BER is greater than 10^{-3} are called spurious response frequencies. For each RX frequency, five spurious response frequencies are allowed. On these spurious response

frequencies, a relaxed interference requirement $C/I = -17$ dB is met. This relaxation does not apply to the following measurements:

- Co-Channel interference, $C/I_{\text{co-channel}}$
- Adjacent (1 MHz) interference, $C/I_{1\text{MHz}}$
- Image frequency Interference, C/I_{image}

RF/RCV/CA/BV-04-C [Blocking Performance]

- Test Purpose

Verification of the receiver's performance in presence of interference.

- Reference

[1] 4.1.3

- Initial Condition

- IUT in test mode loop back.
- Hopping off.
- IUT: $f_{\text{RX}} = f_{\text{TX}} = 2460$ MHz.
- IUT transmits at maximum output power back to the tester.

- Test Procedure

When multiple power classes are declared in the ICS, the test is performed using the power class representing the highest power supported.

- a) The tester continuously sends the wanted nominal signal (see Section 6.1, "Reference Signal Definition") to the IUT.
- b) This wanted signal is transmitted at 3 dB over the reference sensitivity level (see Section 6.6 "Definition of the reference sensitivity level") at $f_{\text{RX}} = 2460$ MHz.
- c) DH1 packets are used. The Payload is PRBS9.
- d) Additionally, the tester produces a continuous wave interfering signal at frequency $f_i = 30$ Mhz, at the IUT receiver input. The power levels of this interfering signal are 2 dB higher as defined in Table 4.7.
- e) Tester measures BER according to Section 6.4 "Bit error rate (BER) measurements" (minimum number of samples, 100 000 returned payload bits.) If the BER is measured to be > 0.1 %, the frequency of the blocking signal is recorded.
- f) Repeat Steps a)–e) for $30 \text{ MHz} \leq f_i \leq 12.75 \text{ GHz}$, with the measurement frequency resolution defined in Table 4.7.
- g) The signal level of the blocking signal is set as in Table 4.7 at the IUT receiver input and the BER (minimum number of samples, 1 600 000 returned payload bits) is measured with the same nominal signal as in b) but for all frequencies found in e). If BER is measured to be > 0.1 % the frequency of the blocking signal is recorded.
- h) The signal level of the blocking signal is reduced to -50 dBm at the IUT receiver input and the BER (minimum number of samples, 1 600 000 returned payload bits) is measured with the same nominal signal as in b) but for all frequencies found in g). If BER is measured to be > 0.1 % the frequency of the blocking signal is recorded.

Interfering Signal Frequency	Interfering Signal Power Level	Measurement frequency resolution
30 – 2000 MHz	-10 dBm	10 MHz
2000 – 2400 MHz	-27 dBm	1 MHz
2500 – 3000 MHz	-27 dBm	1 MHz
3000 MHz – 12.75 GHz	-10 dBm	25 MHz

Table 4.7: Power levels of the CW interfering signal

- Test Condition

Common Test Case Conditions defined in Section 4.2 apply.

- Expected Outcome

Pass verdict

All values as measured fulfill the following conditions.

$BER \leq 0.1\%$ (minimum number of samples, 1 600 000 returned payload bits).

The number of frequencies recorded in Step g) does not exceed 24 and the number of frequencies recorded in Step h) does not exceed 5.

RF/RCV/CA/BV-05-C [Intermodulation Performance]

- Test Purpose

Verification of the receiver's intermodulation characteristics.

- Reference

[1] 4.1.4

- Initial Condition

- IUT in test mode loop back. Hopping off.
- $f_{TX} = f_{RX}$ during the test case.
- IUT transmits at maximum output power back to the tester.
- TSPX_Intermod_Test_Number is declared by the manufacturer of the IUT in the IXIT [7].

- Test Procedure

When multiple power classes are declared in the ICS, the test is performed using the power class representing the highest power supported.

- a) IUT is set to transmit and receive at lowest supported frequency.
- b) The tester continuously sends the wanted nominal signal (see Section 6.1, "Reference Signal Definition") to the IUT. This wanted signal is transmitted at 6 dB over the reference sensitivity level (see Section 6.6 "Definition of the reference sensitivity level") at f_{RX} . DH1 packets are used. The Payload is PRBS9.

- c) Static sine wave signal at f_1 with a power level of -39 dBm.
 - d) A Bluetooth modulated signal (see Section 6.1, “Reference Signal Definition”) at f_2 with a power level of -39 dBm and a payload of PRBS15.
 - e) Such that $f_{TX}=2f_1-f_2$ and $|f_2-f_1| = n * 1$ MHz, where TSPX_Intermod_Test_Number is 3, 4, or 5.
 - f) Measure BER according to Section 6.4 “Bit error rate (BER) measurements” (minimum number of samples, 1 600 000 returned payload bits.)
 - g) Repeat Steps b)–f) for the mid and highest operating frequencies f_{TX} supported by the IUT. These frequencies are defined in Section 6.2.2 “Frequencies for testing, loopback, hopping off”.
- Test Condition
Common Test Case Conditions defined in Section 4.2 apply.
 - Expected Outcome
Pass verdict
All values as measured fulfill the following conditions.
 $BER \leq 0.1\%$

RF/RCV/CA/BV-06-C [Maximum Input Level]

- Test Purpose
Verification of the receiver performance.
- Reference
[1] 4.1.5
- Initial Condition
 - IUT in test mode loop back.
 - Hopping off.
 - IUT transmits at maximum output power back to the tester.
- Test Procedure
When multiple power classes are declared in the ICS, the test is performed using the power class representing the highest power supported.
 - a) IUT receives (f_{RX}) / loops back (f_{TX}) at the lowest operating frequency.
 - b) Tester sends DH1 packets with a nominal Bluetooth signal (see Section 6.1, “Reference Signal Definition”) (payload is the PRBS9) continuously at -20 dBm power at the receiver input of the IUT.
 - c) Tester measures BER according to Section 6.4 “Bit error rate (BER) measurements” (minimum number of samples, 1 600 000 returned payload bits).
 - d) Repeat Steps b)–c) while the IUT receives (f_{RX}) / loops back (f_{TX}) at:
 - The mid operating frequency; and
 - The highest operating frequency.
 These frequencies are defined in Section 6.2.2 “Frequencies for testing, loopback, hopping off”.

- Test Condition

Common Test Case Conditions defined in Section 4.2 apply.

- Expected Outcome

Pass verdict

All values as measured fulfill the following conditions.

$BER \leq 0.1 \%$ (minimum number of samples, 1 600 000 returned payload bits).

4.6.2 Sensitivity bit error rate

Test	Bit error rate	Reference	Input power	Received bits	BER threshold	Pass criteria
RF/RCV/CA/BV-07-C [EDR Sensitivity]	10 ⁻⁴	[1] 4.2.1	-70dBm	1 600 000	7*10 ⁻⁵	BER ≤ 7*10 ⁻⁵ after 1 600 000 bits or BER ≤ 10 ⁻⁴ after 16 000 000 bits
RF/RCV/CA/BV-08-C [EDR BER Floor Performance]	10 ⁻⁵	[1] 4.2.2	-60dBm	8 000 000	7*10 ⁻⁶	BER ≤ 7*10 ⁻⁶ after 8 000 000 bits or BER ≤ 10 ⁻⁵ after 160 000 000 bits

Table 4.8: Bit error rate tests



- Test Purpose

Verification of the receiver sensitivity for the specified bit error rate using a non-ideal transmitter.

- Initial Condition

- IUT in test mode loop back, whitening on.
- Hopping off (transmit and receive frequencies are defined in Section 6.2.2).
- IUT transmits at maximum output power back to the tester.

- Test Procedure

When multiple power classes are declared in the ICS, the test is performed using the power class representing the highest power supported.

1. The tester continuously sends $\pi/4$ -DQPSK packets with the longest supported packet type (2-DHx or 2-EVx) and with maximum length payload containing PRBS9.
2. The tester transmit power is chosen such that the input power to the IUT receiver is specified in Table 4.8, measured over the DPSK modulated portion of the packets.
3. The IUT receives (fRX) at:
 - the lowest operation frequency
4. The properties of the packets are chosen according to Table 4.9. Except for these parameters the reference signal settings of Annex 6.1 “Reference Signal Definition” are used. The tester transmits the first 20 packets using the first parameter set of Table 1. The second 20 packets are transmitted with parameter set 2 and so forth. After the third set of parameters has been used, the tester continues using the first set again.
5. The returned packets are received and the BER is measured by the tester according to Section 6.4 “Bit error rate (BER) measurements”. After 1 600 000 bits have been received the BER is compared with threshold $7 \cdot 10^{-5}$. If the BER is less than this threshold then the tester proceeds to Step 7; otherwise the tester proceeds to Step 6.
6. Sampling is to be continued until a minimum number of 160 000 000 bits payload bits are returned.
7. Repeat Steps 4–6 while the IUT receives (fRX) at:
 - the mid operating frequency
 - the highest operating frequency

If 8DPSK is supported by the IUT then repeat Steps 2–7 while the tester continuously sends 8DPSK packets with the longest supported packet type (3-DHx or 3-EVx) and with maximum length payload containing PRBS9.

Set of parameters	Carrier offset frequency	Symbol time period error
1	0 kHz	0 ppm
2	+65 kHz	+20 ppm
3	-65 kHz	-20 ppm

Table 4.9: Dirty transmitter for enhanced data rate packets

Note: Additionally to the described dirty transmitter signal parameters in the above table, a frequency modulation with a deviation of ± 10 kHz and a synchronized sine wave modulation period of 100 μ s is to be modulated onto the signal starting at the beginning of the DPSK synchronization word to realize the worst case transmitter carrier frequency stability. The frequency modulation alternately switches starting phase between 0 and 180 degrees for successive packets.

- Test Condition

Common Test Case Conditions defined in Section 4.2 apply.

- Expected Outcome

Pass verdict

All values as measured fulfill the pass conditions in Table 4.8: Bit error rate tests at low, medium and high frequencies.

RF/RCV/CA/BV-09-C [EDR C/I Performance]

- Test Purpose

Verification of the receiver performance in the presence of co-/adjacent channel interference.

- Reference

[1] 4.2.3

- Initial Condition

- IUT in test mode loop back, whitening on.
- Hopping off.
- IUT transmits at maximum output power back to the tester.
- TSPX_Inband_Image_Frequency is declared by the manufacturer of the IUT in the IXIT [7].

- Test Procedure

When multiple power classes are declared in the ICS, the test is performed using the power class representing the highest power supported. The IUT's transmit frequency is on the same channel as its receive frequency.

- a) The tester continuously sends as the wanted signal $\pi/4$ -DQPSK packets, according to Section 6.1, "Reference Signal Definition", with the longest supported packet type (2-DHx or 2-EVx) and with maximum length payload containing PRBS9.
- b) The IUT receives (fRX) at:
 - The lowest operation frequency + 3 MHz
- c) The tester transmits power at the input of the IUT (wanted signal) measured over the DPSK modulated portion of the packets is -67 dBm.
- d) The interfering signal is continuously modulated using PRBS15 data. For co-channel measurements, the interferer uses the same modulation as the wanted signal and its properties are as defined in Section 6.1, "Reference Signal Definition". For adjacent channel measurements, the interferer uses GFSK modulation as defined in Section 6.1. For interferer power levels see Table 4.10.
- e) The returned packets are received and the BER is measured by the tester according to Section 6.4. The minimum number of samples is 1 600 000 returned payload bits.



- f) Repeat Steps c)–e) with the interferer at all regular Bluetooth frequencies.
- g) Repeat Steps c)–f) while the IUT receives (fRX) at:
- The mid operating frequency
 - The highest operating frequency – 3 MHz
- h) If 8DPSK is supported by the IUT then repeat Steps b)–g) while the tester continuously sends 8DPSK packets, according to [Annex 6.1 Reference Signal Definition](#), with the longest supported packet type (3-DHx or 3-EVx) and with maximum length payload containing PRBS9.

Frequency of Interference	2Mbps ($\pi/4$ -DQPSK) C/I ratio	3Mbps (8dpsk) C/I ratio
Co-Channel interference, C/I co-channel	13 dB	21 dB
Adjacent (1 MHz) interference ^{Note 1} , C/I 1MHz	0 dB	5 dB
Adjacent (2 MHz) interference ^{Note 1} , C/I 2MHz	-17 dB	-12 dB
Adjacent (≥ 3 MHz) interference ^{Note 1} , C/I ≥ 3 MHz	-28 dB	-20 dB
Image frequency Interference ^{Notes 1, 2, 3} , C/I Image	-7 dB	0 dB
Adjacent (1 MHz) interference to in-band image frequency ^{Notes 1, 2, 3} , C/I Image ± 1 MHz	-15 dB	-8 dB

Table 4.10: Interference Performance

Note 1: If two adjacent channel specifications from [Table 4.10](#) are applicable to the same channel, the more relaxed specification applies.

Note 2: If the image frequency is not equal to $n \times 1$ MHz, then the image reference frequency is defined as the closest $n \times 1$ MHz frequency.

Note 3: TSPX_Inband_Image_Frequency

- Test Condition

Common Test Case Conditions defined in Section [4.2](#) apply.

- Expected Outcome

Pass verdict

All values as measured fulfill the following conditions.

- BER 0.1%

Frequencies where the BER is greater than 10^{-3} are called spurious response frequencies. For each RX frequency, five spurious response frequencies are allowed. On these spurious response frequencies, a relaxed interference requirement $C/I = -15$ dB for $\pi/4$ -DQPSK and $C/I = -10$ dB for 8DPSK is met.

- This relaxation does not apply to the following measurements:
- Co-Channel interference, $C/I_{\text{co-channel}}$



- Adjacent (1 MHz) interference, $C/I_{1\text{MHz}}$
- Image frequency Interference, C/I_{image}

RF/RCV/CA/BV-10-C [EDR Maximum Input Level]

- Test Purpose

Verification of the receiver performance at the maximum specified input signal level.

- Reference

[1] 4.2.4

- Initial Condition

- IUT in test mode loop back, whitening on.
- Hopping off (transmit and receive frequencies are defined in Section 6.2.2).
- IUT transmits at maximum output power back to the tester.

- Test Procedure

When multiple power classes are declared in the ICS, the test is performed using the power class representing the highest power supported.

- a) The tester continuously sends $\pi/4$ -DQPSK packets with the longest supported packet type (2-DHx or 2-EVx) and with maximum length payload containing PRBS9.
- b) The tester transmit power is chosen such that the input power to the IUT receiver is -20dBm, measured over the DPSK modulated portion of the packets.
- c) The IUT receives (fRX) at:
 - The lowest operation frequency
- d) The returned packets are received and the BER is measured by the tester according to Section 6.4 “Bit error rate (BER) measurements”. The minimum number of samples is 1 600 000 returned payload bits.
- e) Repeat Step d) while the IUT receives (fRX) at:
 - The mid operating frequency
 - The highest operating frequency
- f) If 8DPSK is supported by the IUT then repeat Steps b)–e) while the tester continuously sends 8DPSK packets with the longest supported packet type (3-DHx or 3-EVx) and with maximum length payload containing PRBS9.

- Test Condition

Common Test Case Conditions defined in Section 4.3 apply.

- Expected Outcome

Pass verdict

All values as measured fulfill the following conditions:

$$\text{BER} \leq 10^{-3}$$

5 Test case mapping

The Test Case Mapping Table (TCMT) maps test cases to specific requirements in the ICS. The IUT is tested in all roles for which support is declared in the ICS document.

The columns for the TCMT are defined as follows:

Item: Contains a logical expression based on specific entries from the associated ICS document. Contains a logical expression (using the operators AND, OR, NOT as needed) based on specific entries from the applicable ICS document(s). The entries are in the form of y/x references, where y corresponds to the table number and x corresponds to the feature number as defined in the ICS document for RF [3].

If a test case is mandatory within the respective layer, then the y/x reference is omitted.

Feature: A brief, informal description of the feature being tested.

Test Case(s): The applicable test case identifiers are required for Bluetooth Qualification if the corresponding y/x references defined in the Item column are supported. Further details about the function of the TCMT are elaborated in [2].

For the purpose and structure of the ICS/IXIT, refer to [2].

Item	Feature	Test Case(s)
RF 1/9	Default GFSK RF Test	RF/TRM/CA/BV-01-C RF/TRM/CA/BV-02-C RF/TRM/CA/BV-04-C RF/TRM/CA/BV-06-C RF/TRM/CA/BV-07-C RF/TRM/CA/BV-08-C RF/TRM/CA/BV-09-C RF/RCV/CA/BV-01-C RF/RCV/CA/BV-03-C RF/RCV/CA/BV-04-C RF/RCV/CA/BV-05-C RF/RCV/CA/BV-06-C
RF 1/4	Power Control	RF/TRM/CA/BV-03-C
RF 1/9 AND (RF 1/6 OR RF 1/7)	Multi Slot	RF/RCV/CA/BV-02-C
RF 1/10 OR RF 1/11	Default EDR RF Test	RF/TRM/CA/BV-10-C RF/TRM/CA/BV-11-C RF/TRM/CA/BV-12-C RF/TRM/CA/BV-13-C RF/RCV/CA/BV-07-C RF/RCV/CA/BV-08-C RF/RCV/CA/BV-09-C RF/RCV/CA/BV-10-C RF/TRM/CA/BV-15-C RF/TRM/CA/BV-16-C
RF 1/12	Enhanced Power Control	RF/TRM/CA/BV-14-C

Table 5.1: Test case mapping



6 Annex

6.1 Reference Signal Definition

If not stated differently in the corresponding test cases, the IUT always transmits at the maximum output power and the tester transmits with a power between -60 dBm and -40 dBm at the IUT receiver input.

The modulated interfering signal is continuous modulated.

A Bluetooth modulated signal used as “wanted signal” and “interfering signal” is defined as:

- Modulation = GFSK
- Modulation index = $0.32 \pm 1\%$
- BT = $0.5 \pm 1\%$
- Bit Rate = 1 Mbps ± 1 ppm
- Frequency accuracy better than ± 1 ppm
- Free selectable Access Code
- Modulating Data for wanted signal = PRBS9
- Modulating Data for interfering signal = PRBS15

Additionally, the signal follows the ramp up as shown in [Figure 6.1](#).

- t_{rampup} is the time taken for the output power from the signal generator to increase from below -40 dB to with ± 3 dB of the final output power x dBm.
- t_{settling} is the time taken for the output power from the signal generator to reach to within better than ± 1 dB of the final output power x dBm.
- t_{PO} is the time at which the first bit of the preamble begins.

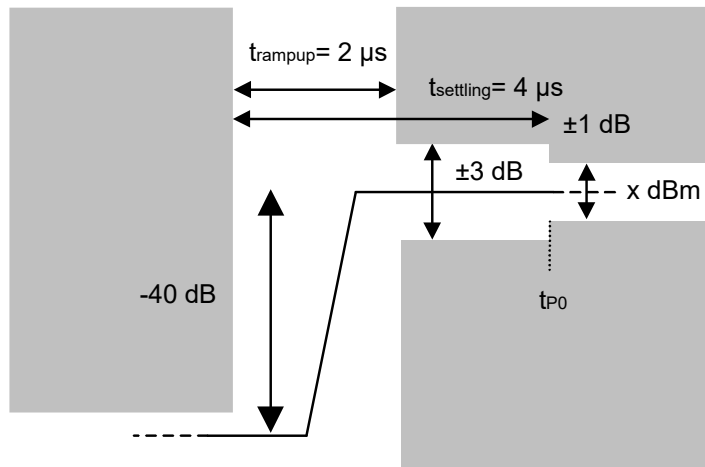

Figure 6.1: Ramp-up profile of signal generator used in Bluetooth RF testing

The lower limit of below -40 dB is very important since above this level, the signal would be of sufficient power to be detected by the receiver.

6.1.1 2 Mbps Reference Signal (EDR)

A 2 Mbps Bluetooth signal used as "wanted" or "interfering signal" is defined as:

- Modulation: $\pi/4$ -DQPSK
- Symbol Rate = 1 Msym/s ± 1 ppm
- Frequency accuracy better than ± 1 ppm
- Modulating Data for wanted signal = PRBS9
- Modulating Data for interfering signal = PRBS15
- RMS Differential Error Vector Magnitude < 5%
- Average power over the GFSK and DPSK portions of the packet is within ± 1 dB

6.1.2 3 Mbps Reference Signal (EDR)

A 3 Mbps Bluetooth signal used as "wanted" or "interfering signal" is defined as:

- Modulation: 8DPSK
- Symbol Rate = 1 Msym/s ± 1 ppm
- Frequency accuracy better than ± 1 ppm
- Modulating Data for wanted signal = PRBS9
- Modulating Data for interfering signal = PRBS15
- RMS Differential Error Vector Magnitude < 5%
- Average power over the GFSK and DPSK portions of the packet is within ± 1 dB

6.2 Frequencies for testing

6.2.1 Operating frequency bands

The Bluetooth system is operating in the 2.4 GHz ISM band.

Regulatory Range	RF Channels used by Bluetooth
2400-2483.5 MHz	$f = 2402 + k$ MHz, $k = 0, \dots, 78$

Table 6.1: Operating frequency bands

6.2.2 Frequencies for testing, loopback, hopping off

Several test cases of this RF Test Suite make use of the Bluetooth test mode, loopback with hopping turned off. These test cases reference to this section and the IUT's receive and transmit frequencies are set according to [Table 6.2](#) and [Table 6.3](#):

For transmit test cases:

Low operating frequency		Mid operating frequency		High operating frequency	
IUT fTX	IUT fRX	IUT fTX ¹	IUT fRX ¹	IUT fTX	IUT fRX
2402 MHz	2480 MHz	2441 MHz	2402 MHz	2480 MHz	2402 MHz

Table 6.2: Frequencies for transmit test cases

For receive test cases:

Low operating frequency		Mid operating frequency		High operating frequency	
IUT fTX	IUT fRX	IUT fTX	IUT fRX	IUT fTX	IUT fRX
2480 MHz	2402 MHz	2402 MHz	2441 MHz	2402 MHz	2480 MHz

Table 6.3: Frequencies for receive test cases

6.2.3 Frequencies for testing, TX-Test, hopping off

Some test cases of this RF Test Suite make use of the Bluetooth test mode, TX-test, with hopping turned off. These test cases reference to this section and the IUT's transmit frequencies are set according to [Table 6.4](#):

Low operating frequency	Mid operating frequency	High operating frequency
IUT fTX	IUT fTX	IUT fTX
2402 MHz	2441 MHz	2480 MHz

Table 6.4: Frequencies TX-test, hopping off

6.3 Normal test conditions

All test cases are performed under the following normal test conditions.

6.3.1 Normal temperature and humidity

The normal temperature and humidity conditions for tests are any convenient combination of temperature and humidity within the following ranges:

- Temperature: +15°C to +35°C
- Relative humidity: 20% to 75%



The actual values during the tests are recorded in the test report.

When it is impracticable to carry out the tests under these conditions, a note to this effect, stating the ambient temperature and relative humidity during the tests, is recorded in the test report.

6.3.2 Nominal Power source

See Section A.1.2 in [1].

6.4 Bit error rate (BER) measurements

BER measurements are carried out by comparing data in the payload fields transmitted by the tester with data in the payload fields received from the IUT. If the tester does not support the loop back method of measuring BER for 2 Mbps or 3 Mbps, it is allowed to use an alternative measurement method as specified in Section 6.2.

Payload as used in this Test Suite will mean the IUT transmitted data. Only Payload data is counted for the BER measurement. The Payload header and Payload CRC are ignored.

If the IUT is unable to loop back a packet (e.g., sync not found or header check fails), this packet is disregarded from the BER measurement. The IUT regenerates the payload CRC based on the actual received payload bits.

Let the number of payload bits counted in error be γ , let the number of payload bits received (via loop back) from the IUT be ξ , then:

$$\text{BER} = \frac{\gamma}{\xi}$$

For BER sensitivity testing and floor testing an Early Exit option applies. If the early exit option is exercised the required number of bits (ξ) and BER Limit are given in Table 6.5 and Table 6.6.

BER Limit	ξ
$7 \cdot 10^{-5}$	1 600 000
$7 \cdot 10^{-6}$	8 000 000

Table 6.5: Number of Bits for BER Limit with Early Exit

For the following BER limits the following values of ξ apply:

BER Limit	ξ
10^{-3}	1 600 000
10^{-4}	16 000 000
10^{-5}	160 000 000

Table 6.6: Number of Bits for BER Limit without Early Exit

6.5 Definition of the position of Bit p0

The start of bit p0, which is the first preamble bit, is defined to occur at the point in time 68 bit periods before the instant at which the modulated carrier passes through the nominal channel frequency immediately prior to the deviation corresponding to the first bit of the Access Code trailer for the IUT as defined in the Baseband Specification Section 4.2.

The position of the start of bit p0 is calculated using an averaging based on the position of all the zero crossings in the packet:

For the m zero crossings in the packet, the i 'th zero crossing time is $t(i)$ in μs ; this is the start of bit $p(i)$.

($1 \leq i \leq m$).

The start of bit p0 is then:

$$t_0 = \frac{1}{m} \sum_{i=1}^m (t(i) - p(i)) * \text{bit time}$$

with bit time is $1\mu\text{s}$.

6.6 Definition of the reference sensitivity level

The reference sensitivity level is defined as -70 dBm.

6.7 Antenna gain

If it is necessary for Regulatory test purposes the TX peak antenna gain is used and declared by the manufacturer.

6.8 Measurement Uncertainty

The following values of measurement uncertainty associated with each measurement parameter apply to all the test cases described in this RF Test Suite.

The measurement uncertainties of the used measurement equipment is equal or better than what is described below. The verdicts of the TCs consider already these measurement uncertainties.”

6.8.1 Conducted measurements:

- Absolute RF power (wanted channel): ± 1.2 dB
- Absolute RF power (for unwanted emissions in the BT band) : ± 3 dB
- Absolute RF power (for unwanted emissions outside the BT band) : ± 3 dB, ± 4 dB for frequencies above 4 GHz

6.8.2 Relative RF power

- Relative RF power: ± 1 dB

6.8.3 Radiated measurements

- Absolute RF power (wanted channel) : ± 6 dB
- Radiated emissions (for unwanted emissions): ± 6 dB

6.8.4 Absolute radio frequency

- Absolute radio frequency: ± 5 kHz

6.8.5 Relative drift radio frequency

- Relative drift radio frequency: ± 1 kHz

6.8.6 Peak frequency deviation

- Peak frequency deviation: ± 4 kHz

7 Revision history and acknowledgments

Revision History

Publication Number	Revision Number	Date	Comments
	D5r3	2003-11-05	Original Release
	D10R00	2004-03-03	Re-partitioned to match Main Specification Volume/Part partitioning.
	1.2.1	2004-03-25	Editorial changes. Changed document numbering and revision number to conform with legacy system.
	1.2.2	2004-07-01	Changed page numbering to begin part with page 1 and made editorial changes to accommodate Vol. 1, Part A.
	1.2.3	2004-08-24	Incorporated TSE 522 changing TP/TRM/CA/BV-06-C
	2.0.E.0	2004-10-19	Incorporated changes for V2.0 + EDR
	2.0.E.1	2004-10-28	Editorial correction to TP/RCV/CA/BV-10-C
10	2.0.E.2	2004-11-04	First version for 1.2/2.0/2.0 + EDR available for qualification
11	2.0.E.3	2005-03-21	Incorporate TSE 686 for the TCMT test cases TRM/CA/BV-10-C, TRM/CA/BV-11-C, TRM/CA/BV-12-C, TRM/CA/BV-13-C, RCV/CA/BV-07-C, RCV/CA/BV-08-C, RCV/CA/BV-09-C, RCV/CA/BV-10-C. Incorporate TSE 687 for RCV/CA/BV-08-C. Incorporate TSE 688 for TRM/CA/BV-13-C. Incorporate TSE 689 for TRM/CA/BV-11-C. Incorporate TSE 690 for RCV/CA/BV-07-C.
12	2.0.E.4	2005-10-14	TSE 719: Explicitly state EUT to support power control for TRM/CA/BV-10-C Changed globally Bluetooth Specification V1.2 [Vol.2, Part A] to [1] to refer to Normative Reference first item.
13	2.1.E.0	2006-12-27	Change document identifier from 2.0.E to 2.1.E TSE 1809: TRM/CA/BV-11-C: Change reference to Appendix C in the RF spec. Update references to include v1.2 and 2.0/2.1 core refreezes Removed "Uncertainties" section
14	2.1.E.1	2007-08-23	TSE 2264: TCMT: change descriptions, remove blanks
15	2.1.E.2	2008-04-30	TSE 2099: RCV/CA/BV-01-C, RCV/CA/BV-02-C, RCV/CA/BV-07-C clarification of timing symbol TSE 2416: TRM/CA/BV-01-C: change hopping to optional
	2.1.E.3r0	2008-11-05	TSE 2473: RCV/CA/BV-03-C, RCV/CA/BV-09-C: Test condition update TSE 2482: TRM/CA/BV-13-C: Update Expected Outcome

Publication Number	Revision Number	Date	Comments
			TSE 2492: RCV/CA/BV-03-C: Remove column in Table 5.7 TSE 2505: TRM/CA/BV-01-C, TRM/CA/BV-02-C. Add clarification to Notes.
16	21.E.3	2008-12-08	Prepare for publication.
	2.1.E.4r0	2009-02-22	New test case TRM/CA/BV-14-C for EPC Updated TCMT to match TPG
17	3.0.H.0/ 2.1.E.4	2009-04-17	Prepare for publication.
	3.0.H.1r0	2009-06-22 2009-08-06	TSE 2700: TRM/CA/BV-05-C: Updated Test procedure and expected outcome. TSE 2482: TRM/CA/BV-06-C: Update Expected Outcome TSE 3083: RCV/CA/BV-03-C, RCV/CA/BV-09-C: Test condition update
18	3.0.H.1	2009-08-06	Prepare for publication.
	4.0.2.r0	2010-12-12	TSE 3153: TRM/CA/BV-14-C: update Test procedure. TSE 3154: TRM/CA/BV-01-C, TRM/CA/BV-03-C, TRM/CA/BV-14-C: update test procedure TSE 3156: TRM/CA/BV-01-C, TRM/CA/BV-03-C: update test procedure TSE 3195: TRM/CA/BV-14-C: update test procedure TSE 3285: TRM/CA/BV-05-C: fix spectrum expression TSE 3407: RCV/CA/BV-03-C, RCV/CA/BV-09-C: update Expected outcome TSE 3409: TRM/CA/BV-09-C: Update Expect Outcome TSE 3455: TRM/CA/BV-05-C: see TSE 3285 TSE 3678: Section 6.5.2
19	4.0.2	2011-07-18	Prepare for publication.
	4.0.3r0	2012-09-06	TSE 4907: Change to test procedure 5.1.8 add, "AND skip to next frequency if the increased frequency equals to fTX or "fTX - 1MHz" or "fTX + 1MHz".
	4.0.3r1	2012-10-22	Added page breaks for new main sections.
20	4.0.3	2012-11-12	Prepare for Publication
	4.1.0	2013-11-11	Updated revision to 4.1.0 Updated references to include version 4.1 Updated top sheet to include version 4.1
21	4.1.0	2013-12-03	Prepare for Publication
	4.1.0 – Template Conversion	2014-01-22	Template Conversion into Template_TS_2014r01

Publication Number	Revision Number	Date	Comments
	4.1.1r00	2014-01-22	TSE 5506: Correctly formatted the TC IDs for TRM/CA/BV-01-C, TRM/CA/BV-02-C, TRM/CA/BV-03-C, TRM/CA/BV-04-C, TRM/CA/BV-05-C, TRM/CA/BV-06-C, TRM/CA/BV-07-C, TRM/CA/BV-08-C, TRM/CA/BV-09-C, TRM/CA/BV-10-C, TRM/CA/BV-11-C, TRM/CA/BV-12-C, TRM/CA/BV-13-C, TRM/CA/BV-14-C, RCV/CA/BV-01-C, RCV/CA/BV-02-C, RCV/CA/BV-03-C, RCV/CA/BV-04-C, RCV/CA/BV-05-C, RCV/CA/BV-06-C, RCV/CA/BV-07-C, RCV/CA/BV-08-C, RCV/CA/BV-09-C, RCV/CA/BV-10-C.
	4.1.1r01	2014-05-09	Review by Dan Ralley: - Added hyperlinks to references within the document
	4.1.1r02	2014-05-21	Review by Siegfried Lehmann: Corrected revision history for 5506. Updated ToC and TCMT for new format.
	4.2.0r00	2014-11-24	Revved to 4.2.0 to align with Core Specification Version 4.2 Release. Updated Test Case numbering convention to match convention in TCRL.
	4.2.0r01	2014-11-24	BTI Review, Alicia, editorial corrections
22	4.2.0	2014-12-04	Prepare for TCRL 2014-2 publication
	4.2.1r00	2015-05-05	Removed page number references throughout document and replaced with functioning links. Addressed incorrect table and figure numbering. TSE 6139: Deleted redundant Core references and replace with a single reference to V2.1 + EDR or later Inserted missing links to the References section into test cases. Updated links in test cases to account for the revised numbering in the References section. Replaced all instances of “must” with “shall” Replaced all instances of EUT with IUT Removed references and phrasing from to outdated versions of EN 300 328 Removed test steps about “country specific hopping sequence” since that was deprecated in the v 1.2 of the Specification Removal of unjustified tests on Extreme test conditions Removal of text about applicability for certain IUTs since that is really handled in the TCMT
	4.2.1r01	2015-05-16	Integrated review from Magnus Sommansson
	4.2.1r02	2015-05-21	Integrated review from Dave Richter – editorial changes
	4.2.1r03	2015-06-03	Further editorial review continuing changes made at 4.2.1r00.

Publication Number	Revision Number	Date	Comments
23	4.2.1	2015-07-14	Prepared for TCRL 2015-1 publication
	4.2.2r00	2015-10-14	TSE 6584: Simplified initial condition regarding coupling device for consistency between tests. Affects TP/TRM/CA/BV-01-C, TP/TRM/CA/BV-14-C, TP/RVC/CA/BV-01-C, TP/RVC/CA/BV-02-C, TP/RVC/CA/BV-03-C, TP/RVC/CA/BV-04-C, TP/RVC/CA/BV-05-C, TP/RVC/CA/BV-06-C. Also corrected typos in TP/TRM/CA/BV-02-C. TSE 6550: Corrected missing header formatting issue by making Extreme test conditions a level 2 header (now Section 6.5). TSE 6507: Added note to TP/TRM/CA/BV-02-C to perform test at each supported power class. All other tests: added note to perform test at highest supported power class.
24	4.2.2	2015-12-22	Prepared for TCRL 2015-2 publication
	4.2.3r00	2016-02-15	TSE 6840: Added new section, Common Test Case Conditions. The following changes applied to all test cases: First initial condition moved to Common Test Case Conditions section. Added new test condition with cross-reference to Common Test Case Conditions section. Deleted test condition moved to Common Test Case Conditions section.
25	4.2.3	2016-07-13	Prepared for TCRL 2016-1 publication.
	5.0.0r00	2016-10-10	TSE 7556: Fixed spelling of "PRBS9" (corrected "PRBS-9" and "PRBS 9"). Affects TP/TRM/CA/BV-01-C – TP/TRM/CA/BV-06-C; TP/TRM/CA/BV-08-C; TP/TRM/CA/BV-14-C; TP/RVC/CA/BV-01-C – TP/RVC/CA/BV-06-C. Updated formatting. TSE 7569: Updated Section 6.5.1 to match new specification text.
	5.0.0r01	2016-10-12	TSE 7492: Updated test case TP/TRM/CA/BV-01-C test procedure with these changes: Removed Steps d) and g), and updated step references; technical update to new Step g); fix condition in "Expected Outcome"; formatted subscript for P_{AV} throughout.
	5.0.0r02	2016-10-19	Corrected "PRBS 15" to "PRBS15" per review by Miles Smith.
26	5.0.0	2016-12-13	Approved by BTI. Prepared for TCRL 2016-2 publication.
	5.0.1r00	2017-03-07	TSE 8138: Moved TP/PHYS/TRX/BV-06-C EDR Guard Time TP/PHYS/TRX/BV-07-C EDR Synchronization Sequence and Trailer from the BB.TS to the RF.TS. Renamed TP/PHYS/TRX/BV-06-C to RF/TRM/CA/BV-15-C, TP/PHYS/TRX/BV-07-C to RF/TRM/CA/BV-16-C.

Publication Number	Revision Number	Date	Comments
	5.0.1r01	2017-03-26	TSE 8334: Modify Initial Condition in RF/TRM/CA/BV-01-C [Output Power] FROM (2nd bullet item which currently says) "Hopping on" TO "IUT hopping on or off".
	5.0.1r02	2017-05-16	Incorporate further BTI review comments. Modify the Change History for TSE 8334 after reviews identified the initial changes were wrongly incorporated. Converted to new Test Case ID conventions as defined in TSTO v4.1.
27	5.0.1	2017-07-05	Approved by BTI. Prepared for TCRL 2017-1 publication.
	5.0.2r00	2018-02-20	TSE 10315 (rating 1): Replaced formula for RF/TRM/CA/BV-07-C.
28	5.0.2	2018-07-02	Approved by BTI. Prepared for TCRL 2018-1 publication.
	5.1.0r00	2018-11-13	Updated revision number to 5.1.0 to align with the adoption of Core Specification version 5.1.
29	5.1.0	2018-12-07	Approved by BTI. Prepared for TCRL 2018-2 publication.
	p30r00	2019-11-12	Revised document numbering convention, setting last release publication of 5.1.0 as p29; added Publication Number column to Revision History. Moved Revision History and Contributors tables to end of doc. Updated Documentation Disclaimer and Confidentiality Markers to align with updated Documentation Marking Requirements. Made minor editorial changes.
30	p30	2020-01-07	Approved by BTI on 2019-12-22. Prepared for TCRL 2019-2 publication.
	p30e2r00	2020-01-13	TSE 13210 (rating 1): Removed duplicated section introduced during 5.0.1 integration.
	p30e2	2020-01-27	Approved by BTI on 2019-01-27. Prepared for edition 2 publication.
	p31r00-r05	2020-01-31 – 2021-03-11	TSE 12811 (rating 1): Removed "Extreme test conditions" section from the Annex; that type of testing is no longer required in the spec. TSE 13594 (rating 2): Updated test steps and added a frequency column to the power levels/frequency table for test case RF/RCV/CA/BV-04-C to harmonize with content in the RF-PHY layer. TSE 15087 (rating 1): Concatenated like items in the TCMT in the same rows. TSE 15230 (rating 1): Removed previous Sections 4.2 and 6.2 to vet obsolete information regarding provisional RF testing. TSE 15249 (rating 1): Updated IXIT items throughout the doc to align with changes made to the Core.IXIT. Template-related editorials. Formatting fixes made by Magnus in interim checkins of r01 (to fix IXIT references) and r05 (to fix sub/superscript text).

Publication Number	Revision Number	Date	Comments
31	p31	2021-07-13	Approved by BTI on 2021-06-27. Prepared for TCRL 2021-1 publication.
	p32r00-r02	2021-10-13 – 2021-10-18	TSE 17648 (rating 1): Updated test purpose for RF/TRM/CA/BV-01-C. TSE 17649 (rating 2): Corrected a typo in RF/TRM/CA/BV-02-C and revised its test procedure to fix the span measurement. TSE 17726 (rating 1): Updated Acknowledgments list.
32	p32	2022-01-25	Approved by BTI on 2021-12-27. Prepared for TCRL 2021-2 publication.
	p33r00	2022-02-28	TSE 18386 (rating 2): Added "Fields and Bits Reserved for Future Use" section. Performed template-related formatting fixes.
33	p33	2022-06-28	Approved by BTI on 2022-05-31. Prepared for TCRL 2022-1 publication.
	p33ed2r00-r01	2023-03-10 – 2023-04-13	TSE 22703 (rating 1): Updated the reference in RF/TRM/CA/BV-08-C and -09-C. Editorial edits to align the document with the latest TS template.
	p33 edition 2	2023-04-14	Approved by BTI on 2023-04-13. Prepared for edition 2 publication.
	p34r00	2024-07-16	TSE 25370 (rating 1): Editorial updates throughout the Test Suite to align with the latest TS template and BTI conventions.
34	p34	2024-09-04	Approved by BTI on 2024-08-14. Prepared for TCRL 2024-2 publication.
	p35r00-r02	2024-11-01 – 2024-12-11	TSE 25102 (rating 2): Per E25101, updated requirements wording by updating the initial condition and test procedure for RF/TRM/CA/BV-01-C – -13-C, updating the test procedure for RF/TRM/CA/BV-14-C, and updating the pass verdict for RF/TRM/CA/BV-01-C. TSE 25104 (rating 1): Updated RF/RCV/CA/BV-09-C to move the test procedure's last step to the test procedure's introduction. TSE 25145 (rating 1): Added a reference to the References list. Added a "Packet sensitivity" section to the "Receiver" section and moved RF/RCV/CA/BV-01-C and RF/RCV/CA/BV-02-C to it. Added a "Sensitivity bit error rate section" to the "Receiver" section and moved RF/RCV/CA/BV-07-C and RF/RCV/CA/BV-08-C to it. TSE 25483 (rating 2): Updated pass verdict for RF/TRM/CA/BV-01-C. TSE 26598 (rating 1): Updated test doc title to better align with the associated spec.
35	p35	2025-02-18	Approved by BTI on 2024-12-26. Prepared for TCRL 2025-1 publication.

Publication Number	Revision Number	Date	Comments
	p36r00	2025-07-30	TSE 25103 (rating 2): Corrected the initial condition, updated the test procedure, and removed the Notes from RF/TRM/CA/BV-08-C and -09-C. TSE 27283 (rating 3): Added an additional Pass verdict to RF/TRM/CA/BV-01-C.
36	p36	2025-11-04	Approved by BTI on 2025-10-05. Prepared for TCRL pkg101 publication.
	p37r00-r01	2025-11-21 – 2026-03-05	TSE 27978 (rating 2): To support ES-25649, updated the test procedure, Pass verdict, and TCMT entry for RF/TRM/CA/BV-03-C. TSE 28296 (rating 2): To support alignment with changes made for ES-28108: deleted RF/TRM/CA/BV-05-C and updated the TCMT accordingly; corrected the Pass verdict for RF/TRM/CA/BV-06-C; corrected the test procedure and Pass verdict for RF/TRM/CA/BV-13-C and RF/RCV/CA/BV-03-C and -09-C.
37	p37	2026-05-05	Approved by BTI on 2026-04-07. Prepared for TCRL pkg103 publication.

Acknowledgments

Name	Company
Totti Huang	Attestation of Global Compliance (Shenzhen) Co., Ltd.
Magnus Sommansson	Cambridge Silicon Radio
Zhang Zhiwei	China Academy of Information and Communications Technology