

# Mesh Binary Large Object Transfer Model (MBTM)

**Bluetooth® Test Suite**

---

- **Revision:** MBTM.TS.p3
- **Revision Date:** 2026-06-23
- **Prepared By:** Mesh Working Group
- **Published during TCRL:** TCRL.pkg104



This document, regardless of its title or content, is not a Bluetooth Specification as defined in the Bluetooth Patent/Copyright License Agreement (“PCLA”) and Bluetooth Trademark License Agreement. Use of this document by members of Bluetooth SIG is governed by the membership and other related agreements between Bluetooth SIG Inc. (“Bluetooth SIG”) and its members, including the PCLA and other agreements posted on Bluetooth SIG’s website located at [www.bluetooth.com](http://www.bluetooth.com).

THIS DOCUMENT IS PROVIDED “AS IS” AND BLUETOOTH SIG, ITS MEMBERS, AND THEIR AFFILIATES MAKE NO REPRESENTATIONS OR WARRANTIES AND DISCLAIM ALL WARRANTIES, EXPRESS OR IMPLIED, INCLUDING ANY WARRANTY OF MERCHANTABILITY, TITLE, NON-INFRINGEMENT, FITNESS FOR ANY PARTICULAR PURPOSE, THAT THE CONTENT OF THIS DOCUMENT IS FREE OF ERRORS.

TO THE EXTENT NOT PROHIBITED BY LAW, BLUETOOTH SIG, ITS MEMBERS, AND THEIR AFFILIATES DISCLAIM ALL LIABILITY ARISING OUT OF OR RELATING TO USE OF THIS DOCUMENT AND ANY INFORMATION CONTAINED IN THIS DOCUMENT, INCLUDING LOST REVENUE, PROFITS, DATA OR PROGRAMS, OR BUSINESS INTERRUPTION, OR FOR SPECIAL, INDIRECT, CONSEQUENTIAL, INCIDENTAL OR PUNITIVE DAMAGES, HOWEVER CAUSED AND REGARDLESS OF THE THEORY OF LIABILITY, AND EVEN IF BLUETOOTH SIG, ITS MEMBERS, OR THEIR AFFILIATES HAVE BEEN ADVISED OF THE POSSIBILITY OF SUCH DAMAGES.

This document is proprietary to Bluetooth SIG. This document may contain or cover subject matter that is intellectual property of Bluetooth SIG and its members. The furnishing of this document does not grant any license to any intellectual property of Bluetooth SIG or its members.

This document is subject to change without notice.

Copyright © 2015–2026 by Bluetooth SIG, Inc. The Bluetooth word mark and logos are owned by Bluetooth SIG, Inc. Other third-party brands and names are the property of their respective owners.



# Contents

<b>1</b>	<b>Scope</b>	<b>5</b>
<b>2</b>	<b>References, definitions, and abbreviations</b>	<b>6</b>
2.1	References	6
2.2	Definitions	6
2.3	Acronyms and abbreviations	6
<b>3</b>	<b>Test Suite Structure (TSS)</b>	<b>7</b>
3.1	Overview	7
3.2	Test Strategy	7
3.3	Test groups	7
<b>4</b>	<b>Test cases (TC)</b>	<b>8</b>
4.1	Introduction	8
4.1.1	Test case identification conventions	8
4.1.2	Conformance	8
4.1.3	Pass/Fail verdict conventions	9
4.2	Setup preambles	9
4.2.1	IUT in Waiting For Transfer Start Phase	9
4.2.2	IUT in Waiting For Next Block Phase	11
4.2.3	IUT in Waiting For Next Chunk Phase	11
4.2.4	IUT in Inactive Phase	12
4.2.5	IUT in Suspended Phase, Block Number Unset	14
4.2.6	IUT in Suspended Phase, Block Number Set	14
4.3	BLOB Transfer Server	14
	MBTM/SR/BT/BV-01-C [Transfer Block Sequence, Push BLOB Transfer Mode]	14
	MBTM/SR/BT/BV-02-C [Transfer Block Sequence, Pull BLOB Transfer Mode]	16
	MBTM/SR/BT/BV-03-C [BLOB Capabilities]	18
	MBTM/SR/BT/BV-04-C [BLOB Transfer Procedure, Push BLOB Transfer Mode]	19
	MBTM/SR/BT/BV-05-C [BLOB Transfer Procedure, Pull BLOB Transfer Mode]	21
	MBTM/SR/BT/BV-06-C [BLOB Transfer – Timeout]	23
	MBTM/SR/BT/BV-07-C [Pull BLOB Transfer – Chunk Timeout]	24
	MBTM/SR/BT/BV-08-C [Pull BLOB Transfer – Reception Timeout]	26
	MBTM/SR/BT/BV-09-C [BLOB Transfer Cancel – IUT in Waiting for Next Block Phase]	28
	MBTM/SR/BT/BV-10-C [Pull BLOB Transfer – Block Complete Timeout]	29
4.3.1	Receive BLOB Transfer Cancel	31
	MBTM/SR/BT/BV-11-C [BLOB Transfer Cancel – IUT in Waiting for Transfer Start Phase]	31
	MBTM/SR/BT/BV-12-C [BLOB Transfer Cancel – IUT in Waiting for Next Chunk Phase]	31
	MBTM/SR/BT/BV-13-C [BLOB Transfer Cancel – IUT in Complete Phase, Push Transfer Mode]	31
	MBTM/SR/BT/BV-14-C [BLOB Transfer Cancel – IUT in Complete Phase, Pull Transfer Mode]	31
	MBTM/SR/BT/BV-15-C [BLOB Transfer Cancel – IUT in Inactive Phase]	31
	MBTM/SR/BT/BV-16-C [BLOB Transfer Cancel – IUT in Suspended Phase]	31
4.3.2	Receive BLOB Transfer Start	32
	MBTM/SR/BT/BV-17-C [BLOB Transfer Start – IUT in Waiting for Next Block Phase]	32
	MBTM/SR/BT/BV-18-C [BLOB Transfer Start – IUT in Waiting for Next Chunk Phase]	32
	MBTM/SR/BT/BV-19-C [BLOB Transfer Start – IUT in Complete Phase, Push Transfer Mode]	32
	MBTM/SR/BT/BV-20-C [BLOB Transfer Start – IUT in Complete Phase, Pull Transfer Mode]	32
	MBTM/SR/BT/BV-21-C [BLOB Transfer Start – IUT in Suspended Phase]	32



MBTM/SR/BT/BV-22-C [BLOB Transfer Start – IUT in Inactive Phase]	32
4.3.3 Receive BLOB Block Start	34
MBTM/SR/BT/BV-23-C [BLOB Block Start – IUT in Waiting for Transfer Start Phase]	34
MBTM/SR/BT/BV-24-C [BLOB Block Start – IUT in Waiting for Next Chunk Phase]	34
MBTM/SR/BT/BV-25-C [BLOB Block Start – IUT in Complete Phase, Push Transfer Mode]	34
MBTM/SR/BT/BV-26-C [BLOB Block Start – IUT in Complete Phase, Pull Transfer Mode]	34
MBTM/SR/BT/BV-27-C [BLOB Block Start – IUT in Suspended Phase, Block Number Set]	34
MBTM/SR/BT/BV-28-C [BLOB Block Start – IUT in Suspended Phase, Block Number Unset]	34
MBTM/SR/BT/BV-29-C [BLOB Block Start – IUT in Inactive Phase]	34
MBTM/SR/BT/BV-30-C [BLOB Transfer Start – Incompatible Parameters]	36
MBTM/SR/BT/BV-31-C [BLOB Transfer Start – Invalid Parameters]	38
MBTM/SR/BT/BV-32-C [BLOB Transfer Cancel – Invalid Parameters]	39
MBTM/SR/BT/BV-33-C [BLOB Block Start – Invalid Parameters]	40
MBTM/SR/BT/BV-34-C [BLOB Chunk Transfer – Invalid Parameters]	42
MBTM/SR/BT/BV-35-C [BLOB Transfer Server State – Default Values]	43
4.3.4 Receive BLOB Block Get	44
MBTM/SR/BT/BV-36-C [BLOB Block Get – IUT in Waiting for Transfer Start Phase]	44
MBTM/SR/BT/BV-37-C [BLOB Block Get – IUT in Suspended Phase]	44
MBTM/SR/BT/BV-38-C [BLOB Block Get – IUT in Inactive Phase]	44
MBTM/SR/BT/BI-01-C [BLOB Transfer Start – RFU Bits]	45
MBTM/SR/BT/BI-02-C [BLOB Transfer Start – Prohibited Transfer Mode]	46
4.4 BLOB Transfer Client	47
MBTM/CL/BT/BV-01-C [Transfer BLOB Procedure, Push BLOB Transfer Mode]	47
MBTM/CL/BT/BV-02-C [Transfer BLOB Procedure, Pull BLOB Transfer Mode]	49
MBTM/CL/BT/BV-03-C [Cancel Transfer Procedure]	51
MBTM/CL/BT/BV-04-C [Transfer BLOB Procedure – Failure]	53
MBTM/CL/BT/BV-05-C [Transfer BLOB Procedure – Transfer Timeout]	54
MBTM/CL/BT/BV-06-C [Transfer BLOB Procedure – Partial Block Report Timeout]	55
MBTM/CL/BT/BV-07-C [Transfer BLOB Procedure – Disable Receiver]	57
MBTM/CL/BT/BV-08-C [Get Transfer Progress Procedure]	59
<b>5 Test case mapping</b>	<b>60</b>
<b>6 Revision history and acknowledgments</b>	<b>63</b>



# 1 Scope

---

This Bluetooth document contains the Test Suite Structure (TSS) and test cases to test the implementation of the Bluetooth Mesh Binary Large Object Transfer Model Specification with the objective to provide a high probability of air interface interoperability between the tested implementation and other manufacturers' Bluetooth devices.



## 2 References, definitions, and abbreviations

---

### 2.1 References

This document incorporates provisions from other publications by dated or undated reference. These references are cited at the appropriate places in the text, and the publications are listed hereinafter. Additional definitions and abbreviations can be found in [1], [2], and [3].

- [1] Mesh Protocol Specification, Version 1.0 or later
- [2] Test Strategy and Terminology Overview
- [3] Mesh Binary Large Object Transfer Model Specification
- [4] ICS Proforma for Mesh Binary Large Object Transfer Model
- [5] IXIT Proforma for Mesh Binary Large Object Transfer Model
- [6] [Appropriate Language Mapping Tables](#) document
- [7] Document Naming and Marking Document

### 2.2 Definitions

In this Bluetooth document, the definitions in [1], [2], and [3] apply.

Certain terms that were identified as inappropriate have been replaced. For a list of the original terms and their replacement terms, see the Appropriate Language Mapping Tables document [6].

### 2.3 Acronyms and abbreviations

In this Bluetooth document, the definitions, acronyms, and abbreviations from [1], [2], and [3] apply.

## 3 Test Suite Structure (TSS)

---

### 3.1 Overview

The Mesh Binary Large Object Transfer Model Specification defines the BLOB Transfer Server model and the BLOB Transfer Client model. Testing is performed by pairing the IUT acting in each of the defined model against a Lower Tester acting in the peer model. IUT and Lower Tester are both mesh nodes provisioned on the same network.

### 3.2 Test Strategy

The test objectives are to verify the functionality of the Mesh Binary Large Object Transfer Model within a Bluetooth Host and enable interoperability between Bluetooth Hosts on different devices. The testing approach covers mandatory and optional requirements in the specification and matches these to the support of the IUT as described in the ICS. Any defined test herein is applicable to the IUT if the ICS logical expression defined in the Test Case Mapping Table (TCMT) evaluates to true.

The test equipment provides an implementation of the Radio Controller and the parts of the Host needed to perform the test cases defined in this Test Suite. A Lower Tester acts as the IUT's peer device and interacts with the IUT over-the-air interface. The configuration, including the IUT, needs to implement similar capabilities to communicate with the test equipment. For some test cases, it is necessary to stimulate the IUT from an Upper Tester. In practice, this could be implemented as a special test interface, a Man Machine Interface (MMI), or another interface supported by the IUT.

This Test Suite contains Valid Behavior (BV) tests complemented with Invalid Behavior (BI) tests where required. The test coverage mirrored in the Test Suite Structure is the result of a process that started with catalogued specification requirements that were logically grouped and assessed for testability enabling coverage in defined test purposes.

When the IUT supports the Low Power feature, an additional Lower Tester is used that simulates a Friend node and establishes a friendship with the IUT. In that case, all messages exchanged between the IUT and the Lower Tester that is driving the test (the one specified in the test procedure) are actually saved in the Friend Queue and retrieved by the IUT with the typical Low Power node polling mechanism. All friendship messages are exchanged with the primary element of the IUT, regardless of which element contains the MBT model instance.

### 3.3 Test groups

The following test groups have been defined:

- BLOB Transfer Server
- BLOB Transfer Client

## 4 Test cases (TC)

### 4.1 Introduction

#### 4.1.1 Test case identification conventions

Test cases are assigned unique identifiers per the conventions in [2]. The convention used here is:

**<spec abbreviation>/<IUT role>/<class>/<feat>/<func>/<subfunc>/<cap>/<xx>-<nn>-<y>**.

Identifier Abbreviation	Spec Identifier <spec abbreviation>
MBTM	Mesh Binary Large Object Transfer
Identifier Abbreviation	Role Identifier <IUT role/model type>
CL	Client Role
SR	Server Role
Identifier Abbreviation	Model Identifier <model identifier>
BT	Binary Large Object Transfer

Table 4.1: MBTM TC feature naming conventions

#### 4.1.2 Conformance

When conformance is claimed for a particular specification, all capabilities are to be supported in the specified manner. The mandated tests from this Test Suite depend on the capabilities to which conformance is claimed.

The Bluetooth Qualification Program may employ tests to verify implementation robustness. The level of implementation robustness that is verified varies from one specification to another and may be revised for cause based on interoperability issues found in the market.

Such tests may verify:

- That claimed capabilities may be used in any order and any number of repetitions not excluded by the specification
- That capabilities enabled by the implementations are sustained over durations expected by the use case
- That the implementation gracefully handles any quantity of data expected by the use case
- That in cases where more than one valid interpretation of the specification exists, the implementation complies with at least one interpretation and gracefully handles other interpretations
- That the implementation is immune to attempted security exploits

A single execution of each of the required tests is required to constitute a Pass verdict. However, it is noted that to provide a foundation for interoperability, it is necessary that a qualified implementation consistently and repeatedly pass any of the applicable tests.

In any case, where a member finds an issue with the test plan generated by the Bluetooth SIG qualification tool, with the test case as described in the Test Suite, or with the test system utilized, the member is required to notify the responsible party via an erratum request such that the issue may be addressed.



### 4.1.3 Pass/Fail verdict conventions

Each test case has an Expected Outcome section. The IUT is granted the Pass verdict when all the detailed pass criteria conditions within the Expected Outcome section are met.

The convention in this Test Suite is that, unless there is a specific set of fail conditions outlined in the test case, the IUT fails the test case as soon as one of the pass criteria conditions cannot be met. If this occurs, the outcome of the test is a Fail verdict.

## 4.2 Setup preambles

The procedures defined in this section are used to achieve specific conditions on the IUT and the test equipment within the tests defined in this document. The preambles here are commonly used to establish initial conditions.

### 4.2.1 IUT in Waiting For Transfer Start Phase

- Preamble Procedure

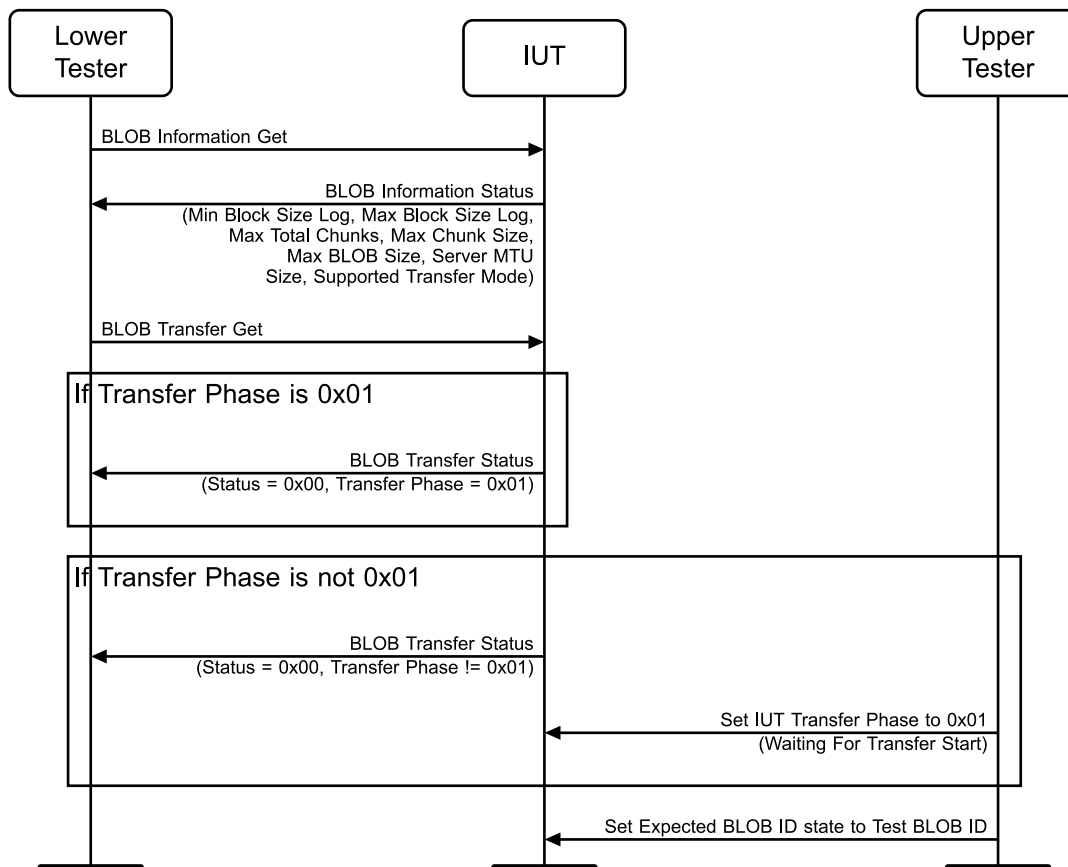

Figure 4.1: IUT in Waiting For Transfer Start phase

1. The Lower Tester sends a BLOB Information Get message to the IUT.
2. The IUT responds with a BLOB Information Status message with the Min Block Size Log, Max Block Size Log, Max Total Chunks, Max Chunk Size, Max BLOB Size, Server MTU Size, and Supported Transfer Mode fields set to valid values. The Lower Tester stores the values of the node capabilities.

3. The Lower Tester sends a BLOB Transfer Get message to the IUT.
4. The IUT responds with a BLOB Transfer Status message with the Status field set to 0x00 (Success) and the Transfer Phase field set to a valid value. If the Transfer Phase field is not set to 0x01 (Waiting For Transfer Start) or 0x00 (Inactive), the message contains the BLOB ID, BLOB Size, Block Size Log, Transfer MTU Size, Blocks Not Received fields set to valid values, and Transfer Mode set to the Supported Transfer Mode value from step 2; otherwise Transfer Mode is set to 0x00 (No Active Transfer). All RFU field bits are set to '0'.
5. If the Transfer Phase field from step 4 is not set to 0x01 (Waiting For Transfer Start), the Upper Tester sets the IUT in Waiting For Transfer Start.
6. The Lower Tester prepares a BLOB with the following parameters:
  - a. Test BLOB ID set to a valid random value.
  - b. Test Max Chunk Size set to  $\min(\text{Transfer MTU Size} - 3, \text{Max Chunk Size})$ .
  - c. Test Max Total Chunks set to  $\min(8 \times (\text{Transfer MTU Size} - 6), \text{Max Total Chunks})$ .
  - d. Test Block Size Log set to  $\min(\text{Max Block Size Log}, \log_2(\text{Test Max Total Chunks} \times \text{Test Max Chunk Size}))$ .
  - e. Test Max Block Count set to  $\min(8 \times (\text{Transfer MTU Size} - 19), \text{ceil}(\frac{\text{MaxBLOBSize}}{2^{\text{TestBlockSizeLog}}}))$
  - f. Test Block Count set to a random value inside the closed range  $[2, \text{Test Max Block Count}]$ .
  - g. Test BLOB Size set to  $\text{Test Block Count} \times 2^{\text{Test Block Size Log}}$ .
  - h. Test BLOB Data set to an array of random octets of size Test BLOB Size.
  - i. For each block  $p$  in the interval  $[0, \text{Test Block Count})$ :
    - i. Test Block Size <sub>$p$</sub>  set to  $2^{\text{Test Block Size Log}}$ , for  $p = [0, \text{Test Block Count} - 2]$  and to  $(\text{Test BLOB Size} - (\text{Test Block Count} - 1) \times 2^{\text{Test Block Size Log}})$  for  $p = \text{Test Block Count} - 1$ .
    - ii. Test BLOB Block <sub>$p$</sub>  Chunk Size set to a random non-zero value smaller than Max Chunk Size.
    - iii. Test BLOB Block <sub>$p$</sub>  Chunk Count set to  $\text{ceil}(\text{Test BLOB Block}_p \text{ Size} / \text{Test BLOB Block}_p \text{ Chunk Size})$ .
    - iv. Test BLOB Blocks Not Received <sub>$p$</sub>  set to a bitfield value of  $\text{ceil}(\text{Test Block Count} / 8)$  bytes, where bits  $p$  to Test Block Count are set to '1' and the rest are set to '0'.
  - j. For each block  $p$  in the interval  $[0, \text{Test Block Count})$  and each chunk  $q$  in the interval  $[0, \text{Test BLOB Block}_p \text{ Chunk Count})$ :
    - i. Test BLOB Block <sub>$p$</sub>  Chunk <sub>$q$</sub>  Size set to Test BLOB Block <sub>$p$</sub>  Chunk Size, for  $p = [0, \text{Test BLOB Block}_p \text{ Chunk Count} - 2]$  and to  $(\text{Test Block Size}_p - (\text{Test BLOB Block}_p \text{ Chunk Count} - 1) \times \text{Test BLOB Block}_p \text{ Chunk Size})$  for  $p = \text{Test BLOB Block}_p \text{ Chunk Count} - 1$ .
    - ii. Test BLOB Block <sub>$p$</sub>  Chunk <sub>$q$</sub>  Data set to the first Test BLOB Block <sub>$p$</sub>  Chunk <sub>$q$</sub>  Size values from Test BLOB Data starting from position  $(p \times 2^{\text{Test Block Size Log}} + (q \times \text{Test BLOB Block}_p \text{ Chunk Size}))$ .
    - iii. Test BLOB Block <sub>$p$</sub>  Missing Chunks set to a bitfield value of  $\text{ceil}(\text{Test BLOB Block}_p \text{ Chunk Count} / 8)$  bytes, where bits 0 to  $(\text{Test BLOB Block}_p \text{ Chunk Count} - 1)$  are set to '1' and the rest are set to '0'.
7. The Upper Tester sets the Expected BLOB ID state on the IUT to Test BLOB ID and the Transfer TTL state on the IUT to TSPX\_Transfer\_TTL.



## 4.2.2 IUT in Waiting For Next Block Phase

- Preamble Procedure

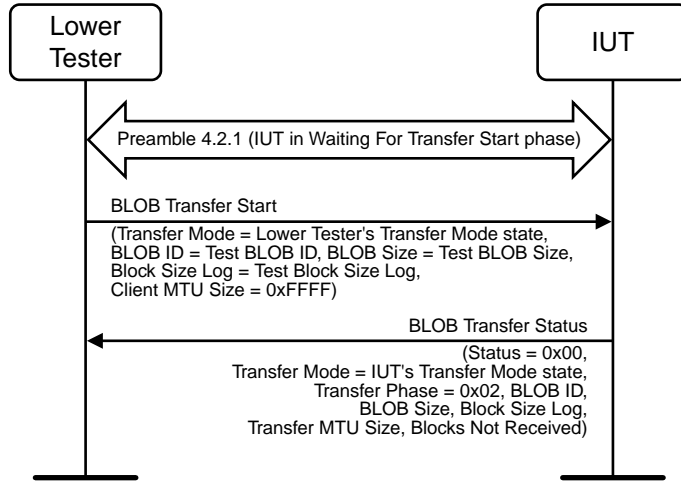

Figure 4.2: IUT in Waiting For Next Block phase

1. The Lower Tester sets the IUT in the Waiting For Transfer Start phase by executing the procedure in Section 4.2.1.
2. The Lower Tester sends a BLOB Transfer Start message to the IUT with Transfer Mode set to the value of the Transfer Mode state of the Lower Tester, BLOB ID set to Test BLOB ID, BLOB Size set to a valid value as calculated in executing step 1, Block Size Log set to Test Block Size Log, and Client MTU Size set to 0xFFFF.
3. The IUT sends a BLOB Transfer Status message with the Status field set to 0x00 (Success), Transfer Mode set to the value of the Transfer Mode state of the IUT, Transfer Phase field set to 0x02 (Waiting For Next Block), the BLOB ID, BLOB Size, and Block Size Log fields set to the values from step 2, Transfer MTU Size set to server MTU size, and the Blocks Not Received field of ceil (Test Block Count / 8) octets. The bitmask value has the least significant Test Block Count bits set to '1' and the rest set to '0'. All RFU field bits are set to '0'.

## 4.2.3 IUT in Waiting For Next Chunk Phase

- Preamble Procedure

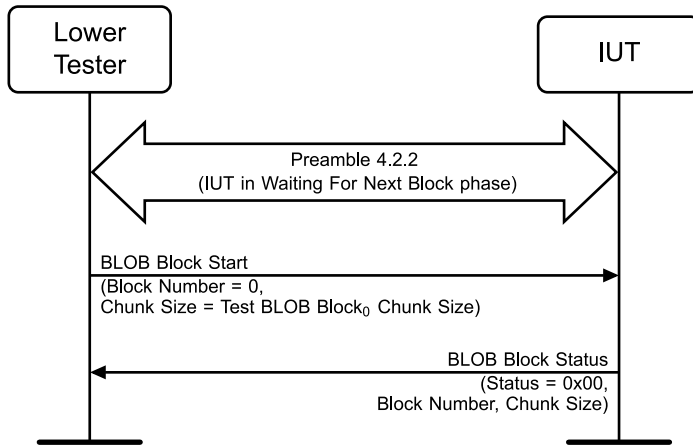

Figure 4.3: IUT in Waiting For Next Chunk phase

1. The Lower Tester sets the IUT in the Waiting For Next Block phase by executing the procedure in Section 4.2.2.
2. The Lower Tester sends a BLOB Block Start message to the IUT with Block Number field set to 0 and Chunk Size field set to Test BLOB Block<sub>0</sub> Chunk Size.
3. The IUT sends a BLOB Block Status message with the Status field set to 0x00 (Success), Block Number field set to 0, and the Chunk Size field set to Test BLOB Block<sub>0</sub> Chunk Size. If the Transfer Mode state is set to 0x02 (Pull) the Format field is set to 0x03 (Encoded Missing Chunks) and the Encoded Missing Chunks field is present, otherwise the Format field is set to 0x0 (All Chunks Missing). All RFU field bits are set to '0'.

#### 4.2.4 IUT in Inactive Phase

- Preamble Procedure

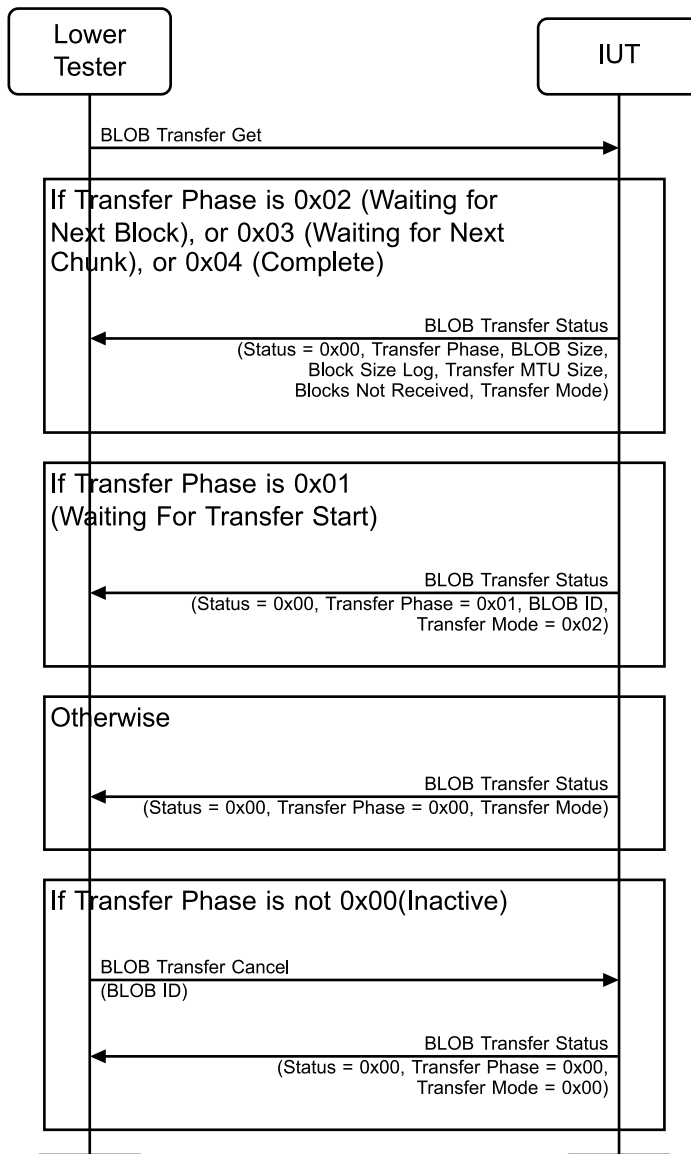

Figure 4.4: IUT in Inactive phase

1. The Lower Tester sends a BLOB Transfer Get message to the IUT.
2. The IUT responds with a BLOB Transfer Status message with the Status field set to 0x00 (Success), the Transfer Phase field set to a valid value. If the Transfer Phase field is not set to 0x00 (Inactive) or 0x05 (Suspended), the message contains the BLOB Size, Block Size Log, Transfer MTU Size, Blocks Not Received fields set to valid values, and Transfer Mode set to the value of the Transfer Mode state of the IUT; otherwise, Transfer Mode is set to 0x00 (No Active Transfer). If the Transfer Phase field is set to 0x01 (Waiting For Transfer Start), the message contains the BLOB ID field. All RFU field bits are set to '0'.
3. If the Transfer Phase field from step 2 is set to 0x00 (Inactive), skip steps 4–5.
4. If the Transfer Phase field from step 2 is set to any value other than 0x00, the Lower Tester sends a BLOB Transfer Cancel message to the IUT with the BLOB ID field set to the value from step 2.
5. The IUT responds with a BLOB Transfer Status message with the Status field set to 0x00 (Success), Transfer Mode is set to 0x00 (No Active Transfer), and the Transfer Phase field set to 0x00 (Inactive).

All RFU field bits are set to '0'.

#### 4.2.5 IUT in Suspended Phase, Block Number Unset

- Preamble Procedure

1. The Lower Tester sets the IUT in Waiting For Next Block phase by executing the preamble procedure in Section 4.2.2.
2. The Lower Tester waits for a timeout computed using TSPX\_Server\_Timeout\_Base.

#### 4.2.6 IUT in Suspended Phase, Block Number Set

- Preamble Procedure

1. The Lower Tester sets the IUT in Waiting For Next Chunk phase by executing the preamble procedure in Section 4.2.3.
2. The Lower Tester waits for a timeout computed using TSPX\_Server\_Timeout\_Base.

### 4.3 BLOB Transfer Server

This test group verifies the BLOB Transfer Server model procedures and behaviors.

#### MBTM/SR/BT/BV-01-C [Transfer Block Sequence, Push BLOB Transfer Mode]

- Test Purpose

Verify that the IUT executes the transfer block sequence when a transfer is already started, using the Push BLOB Transfer Mode.

- Reference

[3] 5.2.5, 5.3.6, 5.3.9

- Initial Condition

- The IUT is set in Waiting For Next Block phase by running the preamble procedure from Section 4.2.2.
- The index of the block that is being transferred is denoted as *i* throughout the test procedure. The value of *i* should be set to 1, unless the test procedure is run when referenced by other test cases in this document, in which case a specific value for *i* is defined by the referencing test case.

- Test Procedure



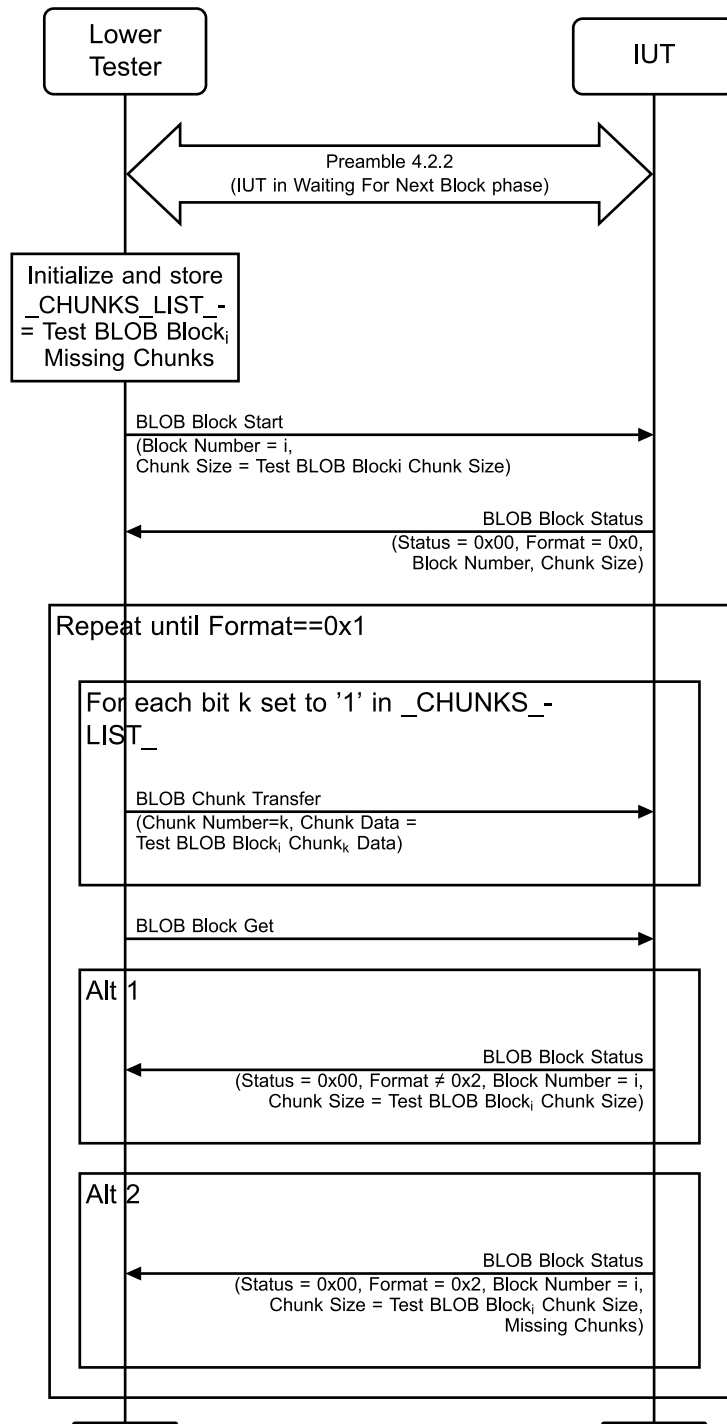

Figure 4.5: MBTM/SR/BT/BV-01-C [Transfer Block Sequence, Push BLOB Transfer Mode]

1. The Lower Tester stores a bitfield of missing chunks for the current block in `_CHUNKS_LIST_`, initialized with Test BLOB Block<sub>i</sub> Missing Chunks.
2. The Lower Tester sends a BLOB Block Start message to the IUT with the Block Number field set to *i* and the Chunk Size field set to Test BLOB Block<sub>i</sub> Chunk Size.
3. The IUT sends a BLOB Block Status message with the Status field set to 0x00 (Success), Format field is set to 0x0 (All Chunks Missing), Block Number field set to *i*, and the Chunk Size field set to Test

BLOB Block<sub>i</sub> Chunk Size. All RFU field bits are set to '0'.

4. For each bit k set to '1' in `_CHUNKS_LIST_`, the Lower Tester sends a BLOB Chunk Transfer message to the IUT with the Chunk Number field set to k and Chunk Data set to Test BLOB Block<sub>i</sub> Chunk<sub>k</sub> Data.
5. The Lower Tester sends a BLOB Block Get message to the IUT.
6. The IUT sends a BLOB Block Status message with the Status field set to 0x00 (Success), Format field is set to a valid value, Block Number field set to i, and the Chunk Size field set to Test BLOB Block<sub>i</sub> Chunk Size. If the Format field is set to 0x2 (Some Chunks Missing), the message contains the Missing Chunks field set to a bitfield value of  $\text{ceil}(\text{Test BLOB Block}_i \text{ Chunk Count} / 8)$  bytes long. All RFU field bits are set to '0'.
7. The Lower Tester updates the `_CHUNKS_LIST_` by applying a logical AND ( $\wedge$ ) with the Missing Chunks field from step 6 (`_CHUNKS_LIST_  $\wedge$  Missing Chunks`).
8. Repeat steps 4–7 until the Format field in step 6 is set to 0x1 (No Missing Chunks).

- Expected Outcome

Pass verdict

The IUT sends BLOB Block Status messages with the expected values and Transfer TTL set to `TSPX_Transfer_TTL`. If present, bits Test BLOB Block<sub>i</sub> Chunk Count and greater from the Missing Chunks field are set to '0'.

For each iteration in step 8, the Missing Chunks field reports the same or fewer missing chunks.

## MBTM/SR/BT/BV-02-C [Transfer Block Sequence, Pull BLOB Transfer Mode]

- Test Purpose

Verify that the IUT executes the transfer block sequence when a transfer is already started, using the Pull BLOB Transfer mode.

- Reference

[3] 5.2.4, 5.3.6, 5.3.9

- Initial Condition

- The IUT is set in Waiting For Next Block phase by running the preamble procedure from Section 4.2.2.

- Test Procedure



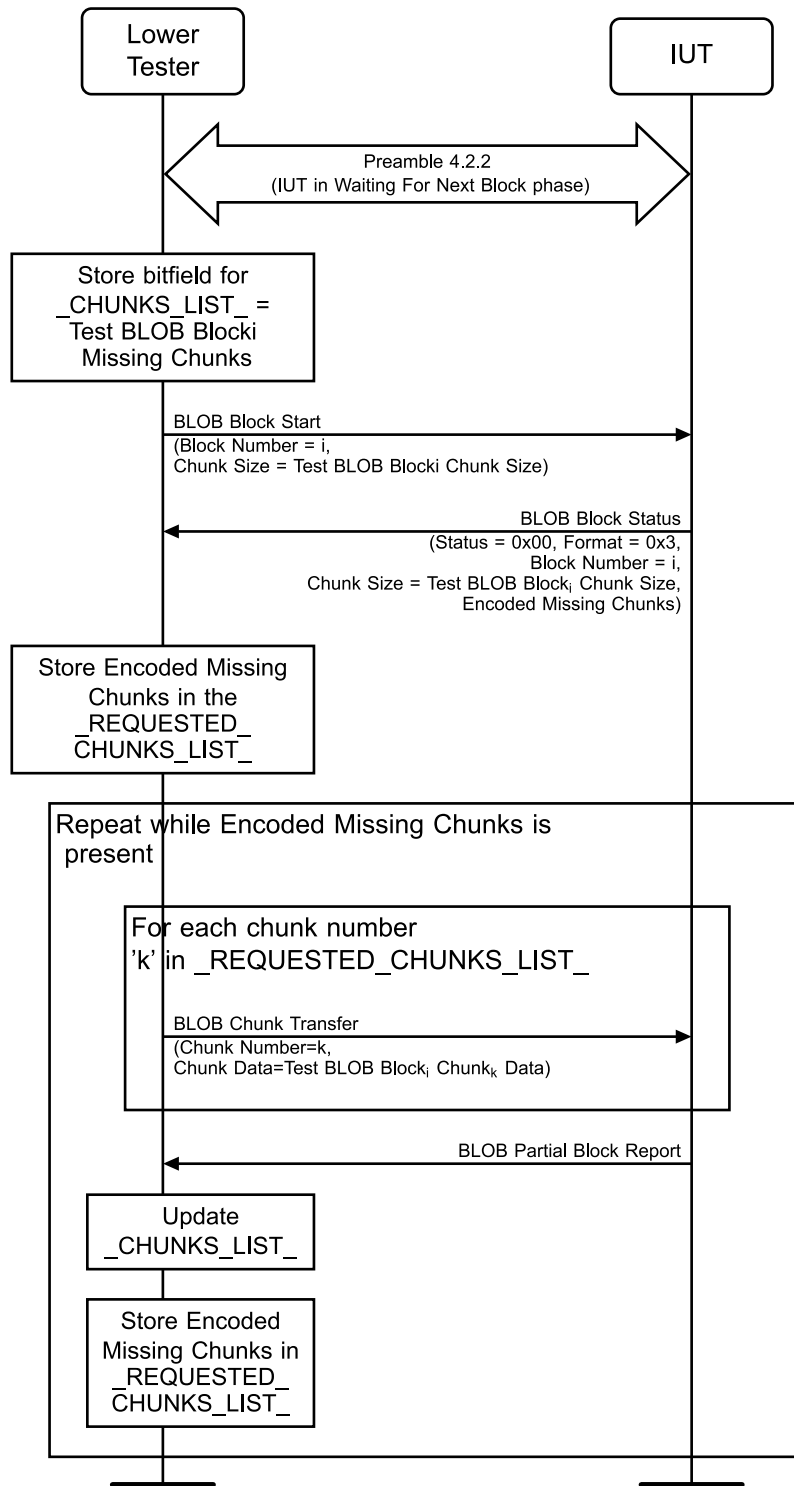

Figure 4.6: MBTM/SR/BT/BV-02-C [Transfer Block Sequence, Pull BLOB Transfer mode]

1. The Lower Tester stores a bitfield of missing chunks for the current block in `_CHUNKS_LIST_`, initialized with Test BLOB Block<sub>i</sub> Missing Chunks.
2. The Lower Tester sends a BLOB Block Start message to the IUT with the Block Number field set to 'i' and the Chunk Size field set to Test BLOB Block<sub>i</sub> Chunk Size.

3. The IUT responds with a BLOB Block Status message with the Status field set to 0x00 (Success), Format field is set to 0x3 (Encoded Missing Chunks), Block Number field set to l, the Chunk Size field set to Test BLOB Block<sub>l</sub> Chunk Size, and Encoded Missing Chunks field set to a list of chunk numbers. All RFU field bits are set to "".
4. The Lower Tester stores the Encoded Missing Chunks from step 3 field in the `_REQUESTED_CHUNKS_LIST_`.
5. For each chunk number "" in `_REQUESTED_CHUNKS_LIST_`, the Lower Tester sends a BLOB Chunk Transfer message to the IUT with the Chunk Number field set to k and Chunk Data set to Test BLOB Block<sub>l</sub> Chunk<sub>k</sub> Data.
6. The IUT sends a BLOB Partial Block Report to the Lower Tester. The Lower Tester updates the `_CHUNKS_LIST_` by clearing the bit corresponding to the chunks sent in step 5 and missing in the Encoded Missing Chunks field.
7. If the Encoded Missing Chunks field is present in step 6, store the Encoded Missing Chunks field in `_REQUESTED_CHUNKS_LIST_` and repeat steps 5–7.

- Expected Outcome

Pass verdict

The IUT sends BLOB Block Status and BLOB Partial Block Report messages with the expected values and Transfer TTL set to TSPX\_Transfer\_TTL.

The interval between each BLOB Partial Block Report is not greater than the Reception timer interval of 31 s.

The `_CHUNKS_LIST_` on the Lower Tester is all zeros.

## MBTM/SR/BT/BV-03-C [BLOB Capabilities]

- Test Purpose

Verify that the IUT receives a BLOB Information Get message and sends a BLOB Information Status message with valid fields.

- Reference

[3] 3.2.7, 5.3.10, 5.3.11

- Initial Condition

- The BLOB Transfer procedure is not active on the IUT.
- The IUT is subscribed to a shared group address.

- Test Procedure



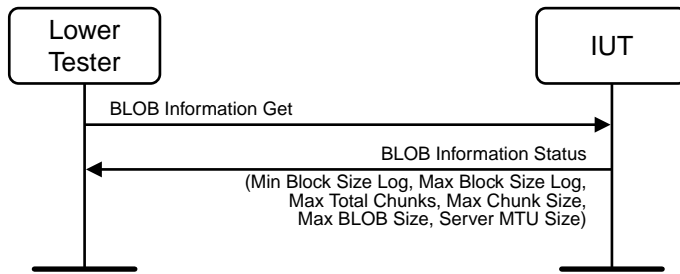

Figure 4.7: MBTM/SR/BT/BV-03-C [BLOB Capabilities]

1. The Lower Tester sends a BLOB Information Get message to the shared group address.
2. The IUT responds with a BLOB Information Status message with the Min Block Size Log, Max Block Size Log, Max Total Chunks, Max Chunk Size, Max BLOB Size, Server MTUM Size, and Supported Transfer Mode fields set to valid values.

- Expected Outcome

Pass verdict

The IUT responds with a BLOB Information Status message with the expected field values and Transfer TTL set to a valid value.

The reported Max Block Size Log value is greater than or equal to the Min Block Size Log value.

### MBTM/SR/BT/BV-04-C [BLOB Transfer Procedure, Push BLOB Transfer Mode]

- Test Purpose

Verify that the IUT accepts a BLOB transfer procedure initiated by the Lower Tester.

- Reference

[3] 5.2.5

- Initial Condition

- The IUT is set in the Waiting For Transfer Start phase by running the preamble procedure from Section 4.2.1.

- Test Procedure

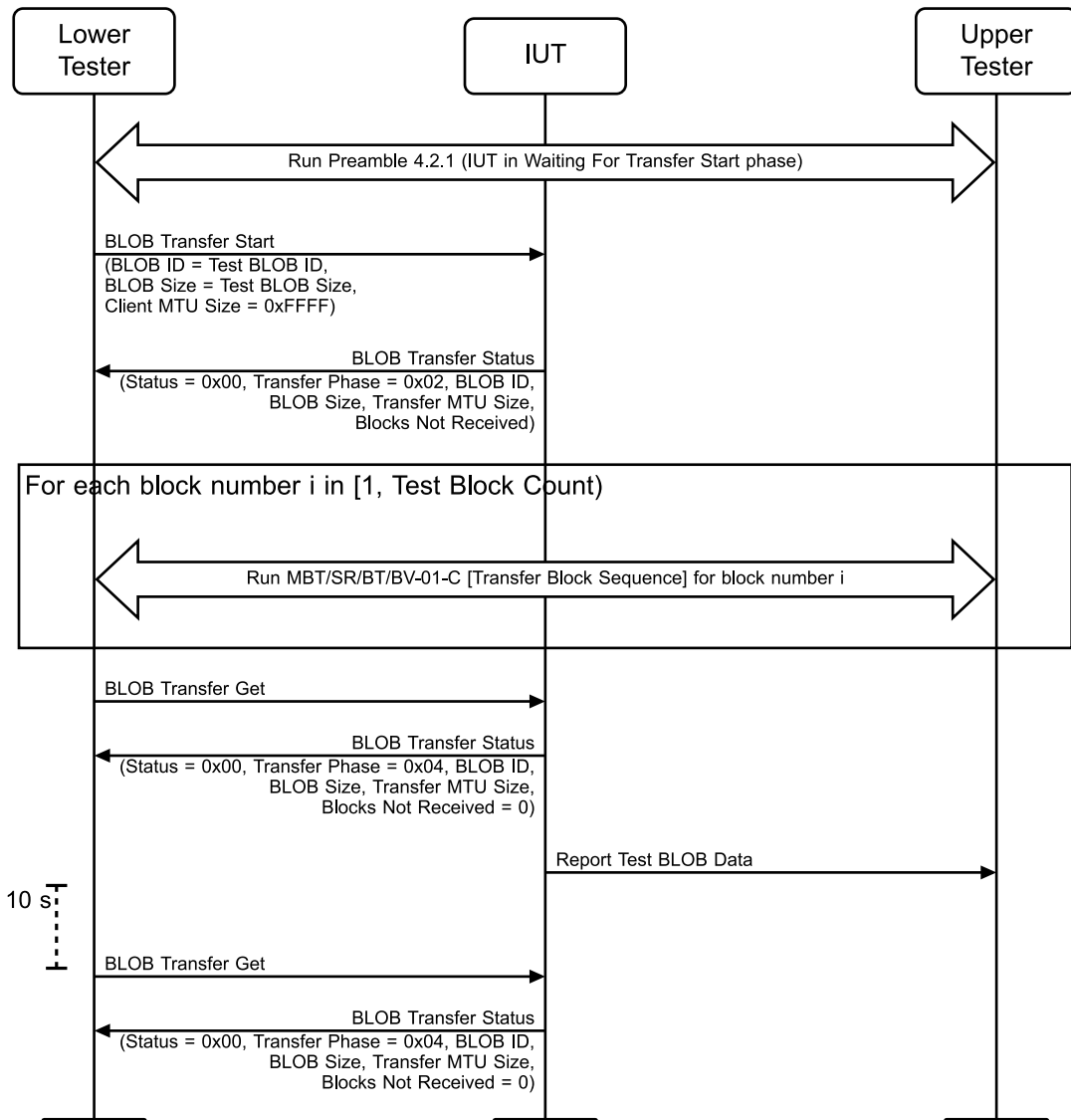

Figure 4.8: MBTM/SR/BT/BV-04-C [BLOB Transfer Procedure, Push BLOB Transfer Mode]

1. The Lower Tester sends a BLOB Transfer Start message to the IUT with Transfer Mode set to 0x01 (Push), BLOB ID set to Test BLOB ID, BLOB Size set to Test BLOB Size, Block Size Log set to Test Block Size Log, and Client MTU Size set to 0xFFFF.
2. The IUT sends a BLOB Transfer Status message with the Status field set to 0x00 (Success), Transfer Mode set to 0x01 (Push), Transfer Phase field set to 0x02 (Waiting For Next Block), the BLOB ID, BLOB Size, and Block Size Log fields set to the values from step 1, Transfer MTU Size set to a valid value, and the Blocks Not Received field of ceil (Test Block Count / 8) octets. The bitmask value has the least significant Test Block Count bits set to '1' and the rest set to '0'. All RFU field bits are set to '0'.
3. For each block number  $i$  in the half-open interval  $[1, \text{Test Block Count})$ , repeat the Transfer Block Sequence with Push BLOB Transfer mode procedure in [MBTM/SR/BT/BV-01-C \[Transfer Block Sequence, Push BLOB Transfer Mode\]](#). The Lower Tester will transfer the blocks in a non-sequential manner.

4. The Lower Tester sends a BLOB Transfer Get message to the IUT.
5. The IUT responds with a BLOB Transfer Status message with the Status field set to 0x00 (Success), Transfer Mode set to 0x01 (Push), the Transfer Phase field set to 0x04 (Complete), the BLOB ID, BLOB Size, and Block Size Log fields set to the values from step 1, Transfer MTU Size set to a valid value, Blocks Not Received set to zeros. All RFU field bits are set to '0'.
6. The IUT reports the Test BLOB Data to the Upper Tester.
7. After 10 s (timeout value), repeat steps 4–5.

- Expected Outcome

Pass verdict

The IUT responds with BLOB Transfer Status messages with the expected values and Transfer TTL set to TSPX\_Transfer\_TTL.

For each block number, the IUT successfully executes the Transfer Block Sequence procedure from [MBTM/SR/BT/BV-01-C \[Transfer Block Sequence, Push BLOB Transfer Mode\]](#).

The IUT successfully reports the Test BLOB Data to the Upper Tester.

The IUT does not timeout the BLOB transfer.

## **MBTM/SR/BT/BV-05-C [BLOB Transfer Procedure, Pull BLOB Transfer Mode]**

- Test Purpose

Verify that the IUT accepts a BLOB transfer procedure initiated by the Lower Tester.

- Reference

[\[3\] 5.2.4](#)

- Initial Condition

- If the IUT supports the Low Power feature, then a friendship is established between the IUT and an additional Lower Tester (acting as Friend node).
- After the friendship has been established, the IUT is set in the Waiting For Transfer Start phase by running the preamble procedure from Section [4.2.1](#).

- Test Procedure



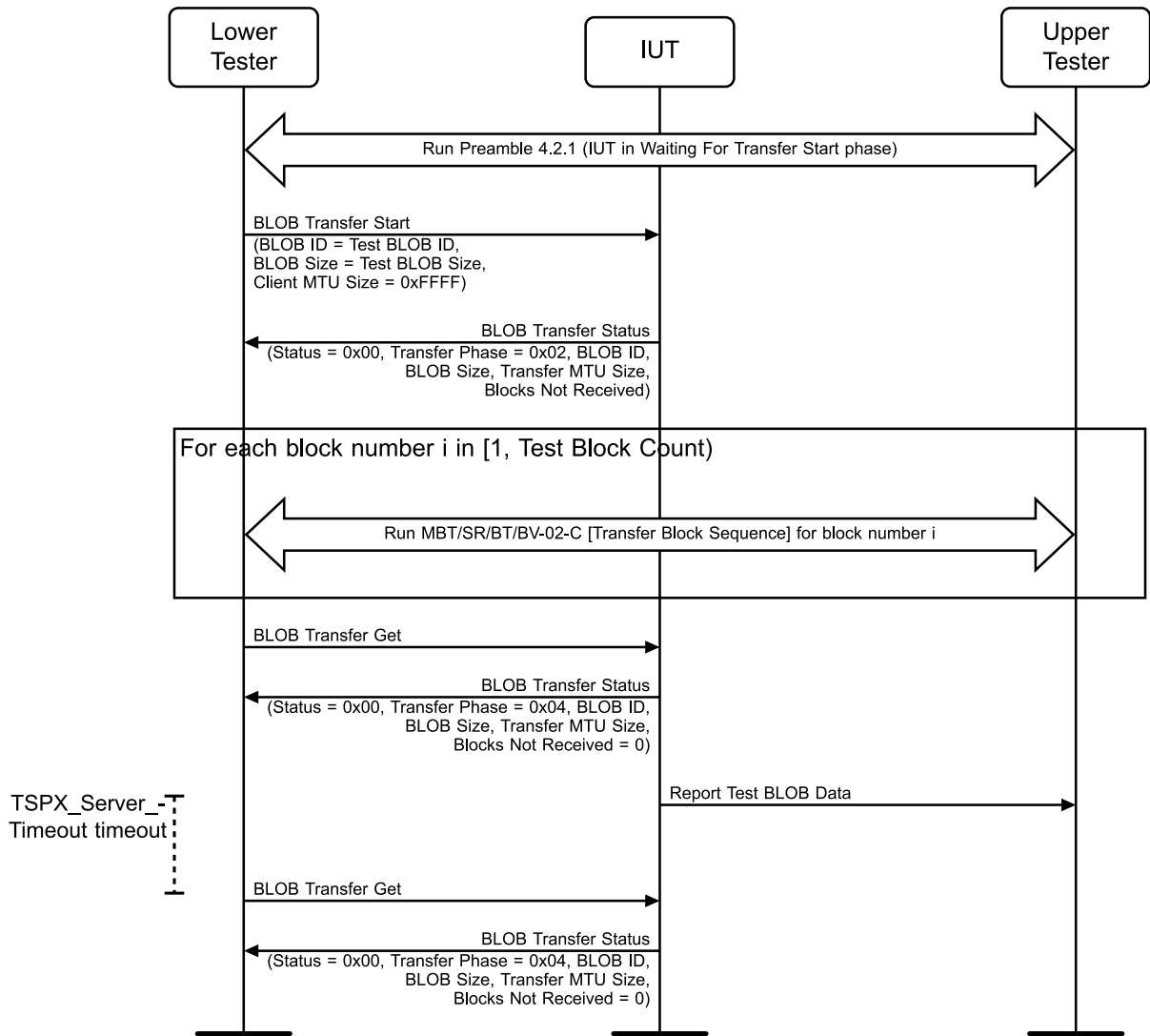

Figure 4.9: MBTM/SR/BT/BV-05-C [BLOB Transfer Procedure, Pull BLOB Transfer Mode]

1. The Lower Tester sends a BLOB Transfer Start message to the IUT with Transfer Mode set to 0x02 (Pull), BLOB ID set to Test BLOB ID, BLOB Size set to Test BLOB Size, Block Size Log set to Test Block Size Log, and Client MTU Size set to 0xFFFF.
2. The IUT sends a BLOB Transfer Status message with the Status field set to 0x00 (Success), Transfer Mode set to 0x02 (Pull), Transfer Phase field set to 0x02 (Waiting For Next Block), the BLOB ID, BLOB Size, and Block Size Log fields set to the values from step 1, Transfer MTU Size set to a valid value, and the Blocks Not Received field of ceil (Test Block Count / 8) octets. The bitmask value has the least significant Test Block Count bits set to '1' and the rest set to '0'. All RFU field bits are set to '0'.
3. For each block number  $i$  in the half-open interval  $[1, \text{Test Block Count})$ , repeat the Transfer Block Sequence with Pull BLOB Transfer mode procedure in [MBTM/SR/BT/BV-02-C \[Transfer Block Sequence, Pull BLOB Transfer Mode\]](#). The Lower Tester will transfer the blocks in a non-sequential manner.
4. The Lower Tester sends a BLOB Transfer Get message to the IUT.
5. The IUT responds with a BLOB Transfer Status message with the Status field set to 0x00 (Success), Transfer Mode set to 0x02 (Pull), the Transfer Phase field set to 0x04 (Complete), the BLOB ID, BLOB



Size, and Block Size Log fields set to the values from step 1, Transfer MTU Size set to a valid value, and Blocks Not Received set to zeros. All RFU field bits are set to '0'.

6. The IUT reports the Test BLOB Data to the Upper Tester.

7. After a timeout computed using TSPX\_Server\_Timeout\_Base, repeat steps 4–5.

- Expected Outcome

#### Pass verdict

The IUT responds with BLOB Transfer Status messages with the expected values and Transfer TTL set to TSPX\_Transfer\_TTL.

For each block number, the IUT successfully executes the Transfer Block Sequence procedure from [MBTM/SR/BT/BV-02-C \[Transfer Block Sequence, Pull BLOB Transfer Mode\]](#).

The IUT successfully reports the Test BLOB Data to the Upper Tester.

### **MBTM/SR/BT/BV-06-C [BLOB Transfer – Timeout]**

- Test Purpose

Verify that an IUT acting as a BLOB Transfer server times out an in-progress transfer procedure.

- Reference

[3] 3.2.6, 5.2.4, 5.2.5

- Initial Condition

- The IUT is set in the Waiting For Next Block phase by running the preamble procedure in Section [4.2.2](#).

- Test Procedure

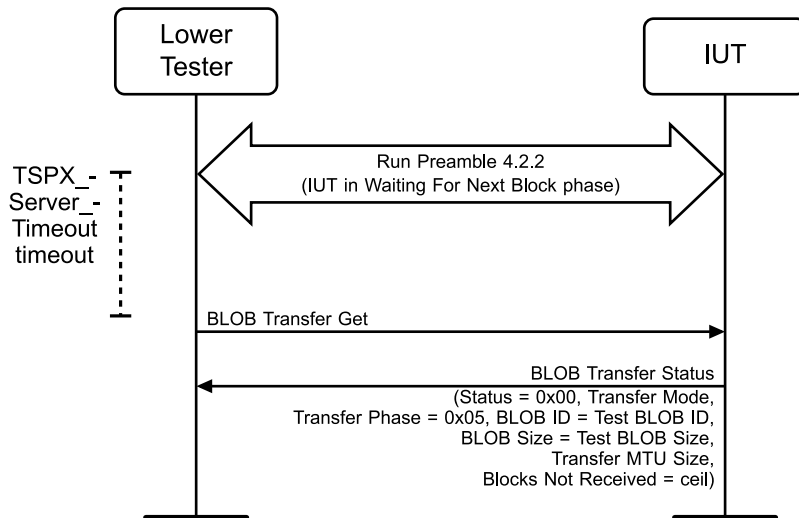

Figure 4.10: MBTM/SR/BT/BV-06-C [BLOB Transfer – Timeout]

1. After a timeout computed using TSPX\_Server\_Timeout\_Base, the Lower Tester sends a BLOB Transfer Get message to the IUT.
2. The IUT sends a BLOB Transfer Status message with the Status field set to 0x00 (Success), Transfer Mode set to the value of the Transfer Mode state of the IUT, Transfer Phase field set to 0x05 (Suspended), BLOB ID set to Test BLOB ID, BLOB Size set to Test BLOB Size, Block Size Log set to Test Block Size Log, Transfer MTU Size set to a valid value, and the Blocks Not Received field of ceil (Test Block Count / 8) octets. The bitmask value has the least significant Test Block Count bits set to '1' and the rest set to '0'. All RFU field bits are set to '0'.

- Expected Outcome

Pass verdict

The IUT responds with BLOB Transfer Status messages with the expected field values.

### MBTM/SR/BT/BV-07-C [Pull BLOB Transfer – Chunk Timeout]

- Test Purpose

Verify that a BLOB Transfer server IUT times out the New Chunk Timer on BLOB transfer using the Pull BLOB Transfer mode.

- Reference

[3] 5.2.4

- Initial Condition

- If the IUT supports the Low Power feature, then a friendship is established between the IUT and an additional Lower Tester (acting as Friend node).
- After the friendship has been established, the IUT is set in the Waiting For Transfer Start phase by running the preamble procedure from Section 4.2.1.

• Test Procedure

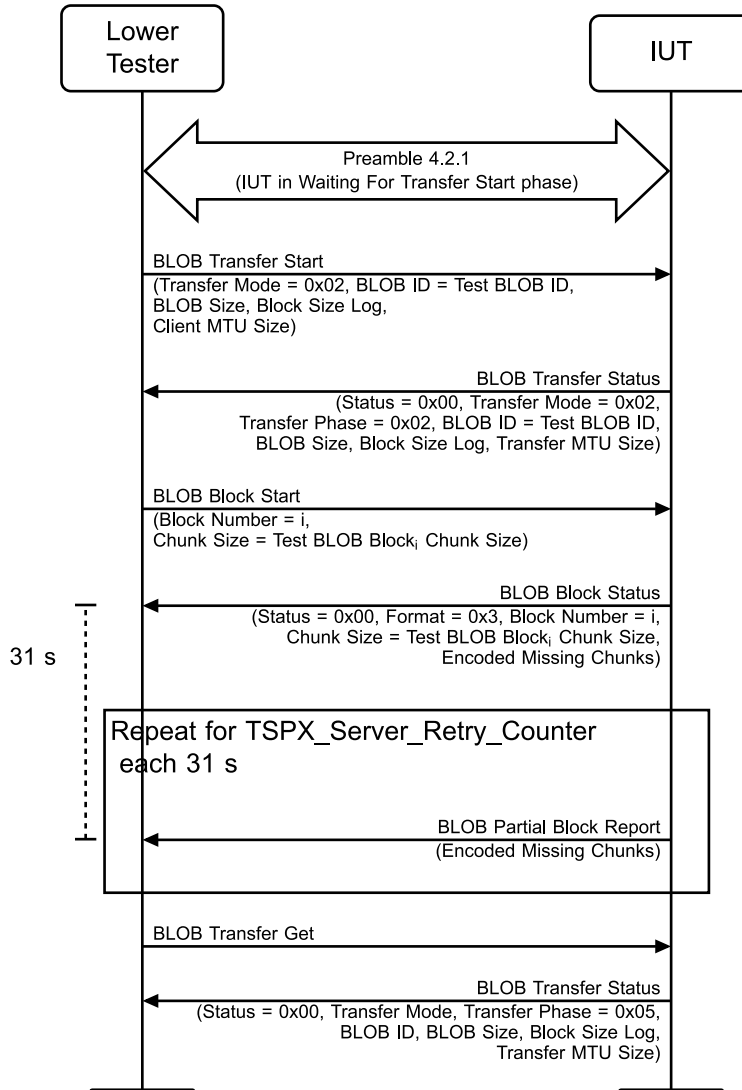

Figure 4.11: MBTM/SR/BT/BV-07-C [Pull BLOB Transfer - Chunk Timeout]

1. The Lower Tester sends a BLOB Transfer Start message to the IUT with Transfer Mode set to 0x02 (Pull), BLOB ID set to Test BLOB ID, BLOB Size set to Test BLOB Size, Block Size Log set to Test Block Size Log, and Client MTU Size set to 0xFFFF.
2. The IUT sends a BLOB Transfer Status message with the Status field set to 0x00 (Success), Transfer Mode set to 0x02 (Pull), Transfer Phase field set to 0x02 (Waiting For Next Block), the BLOB ID, BLOB Size, and Block Size Log fields set to the values from step 1, Transfer MTU Size set to a valid value, and the Blocks Not Received field of ceil (Test Block Count / 8) octets. The bitmask value has the least significant Test Block Count bits set to '1' and the rest set to '0'.
3. The Lower Tester sends a BLOB Block Start message to the IUT with the Block Number field set to 'i' and the Chunk Size field set to Test BLOB Block<sub>i</sub> Chunk Size.
4. The IUT responds with a BLOB Block Status message with the Status field set to 0x00 (Success), Format field is set to 0x3 (Encoded Missing Chunks), Block Number field set to i, the Chunk Size field set to Test BLOB Block<sub>i</sub> Chunk Size, and Encoded Missing Chunks field set to a list of chunk numbers.



All RFU field bits are set to '0'.

5. The Lower Tester does not send any further messages, and within 31 s, the IUT sends a BLOB Partial Block Report to the Lower Tester with the Encoded Missing Chunks field set to a valid value.
6. Repeat step 5 until the server timeout expires. The interval between any two consecutive BLOB Partial Block Report messages is less than or equal to 31 s.
7. After the server timeout expires, the Lower Tester sends a BLOB Transfer Get message to the IUT.
8. The IUT sends a BLOB Transfer Status message with the Status field set to 0x00 (Success), Transfer Mode set to 0x02 (Pull), Transfer Phase field set to 0x05 (Suspended), BLOB ID set to Test BLOB ID, BLOB Size set to Test BLOB Size, Block Size Log set to Test Block Size Log, Transfer MTU Size set to a valid value, and the Blocks Not Received field of ceil (Test Block Count / 8) octets. The bitmask value has the least significant Test Block Count bits set to '1' and the rest set to '0'.

- Expected Outcome

Pass verdict

The IUT responds with BLOB Transfer Status messages with the expected field values.

In steps 5–6, The IUT sends BLOB Partial Block Report messages with the expected field values, each within 31 s of the previous one.

After step 6, the IUT sends no BLOB Partial Block Report messages.

## MBTM/SR/BT/BV-08-C [Pull BLOB Transfer – Reception Timeout]

- Test Purpose

Verify the behavior of an IUT acting as a BLOB Transfer server when the Reception timer expires after a BLOB transfer has begun in Pull BLOB Transfer mode.

- Reference

[3] 5.2.4

- Initial Condition

- If the IUT supports the Low Power feature, then a friendship is established between the IUT and an additional Lower Tester (acting as Friend node).
- After the friendship has been established, the IUT is set in the Waiting For Transfer Start phase by running the preamble procedure from Section 4.2.1.

- Test Procedure



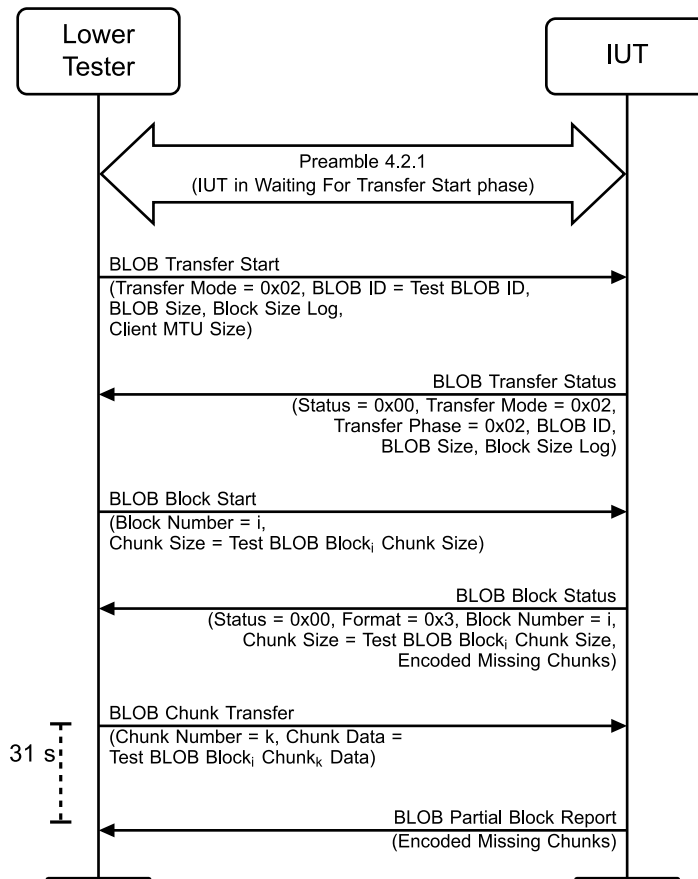

Figure 4.12: MBTM/SR/BT/BV-08-C [Pull BLOB Transfer - Reception Timeout]

1. The Lower Tester sends a BLOB Transfer Start message to the IUT with Transfer Mode set to 0x02 (Pull), BLOB ID set to Test BLOB ID, BLOB Size set to Test BLOB Size, Block Size Log set to Test Block Size Log, and Client MTU Size set to 0xFFFF.
2. The IUT sends a BLOB Transfer Status message with the Status field set to 0x00 (Success), Transfer Mode set to 0x02 (Pull), Transfer Phase field set to 0x02 (Waiting For Next Block), the BLOB ID, BLOB Size, and Block Size Log fields set to the values from step 1, Transfer MTU Size set to server MTU size, and the Blocks Not Received field of ceil (Test Block Count / 8) octets. The bitmask value has the least significant Test Block Count bits set to '1' and the rest set to '0'.
3. The Lower Tester sends a BLOB Block Start message to the IUT with the Block Number field set to 'i' and the Chunk Size field set to Test BLOB Block<sub>i</sub> Chunk Size.
4. The IUT responds with a BLOB Block Status message with the Status field set to 0x00 (Success), Format field is set to 0x3 (Encoded Missing Chunks), Block Number field set to i, the Chunk Size field set to Test BLOB Block<sub>i</sub> Chunk Size, and Encoded Missing Chunks field set to a list of chunk numbers. All RFU field bits are set to '0'.
5. The Lower Tester sends a BLOB Chunk Transfer message to the IUT with the Chunk Number field set to 'k' and Chunk Data set to Test BLOB Block<sub>i</sub> Chunk<sub>k</sub> Data, where k is a chunk number from the Encoded Missing Chunks field from step 4.
6. After 31 s, the IUT sends a BLOB Partial Block Report message to the Lower Tester with the Encoded Missing Chunks field set to a list of chunk numbers, except the chunk transferred in step 5.

- Expected Outcome

Pass verdict

The IUT responds with BLOB Partial Block Report, BLOB Transfer Status, and BLOB Block Status messages with the expected field values and Transfer TTL set to TSPX\_Transfer\_TTL.

**MBTM/SR/BT/BV-09-C [BLOB Transfer Cancel – IUT in Waiting for Next Block Phase]**

- Test Purpose

Verify that when the IUT receives a valid BLOB Transfer Cancel message, it responds with a BLOB Transfer Status message.

- Reference

[3] 5.3.3

- Initial Condition

- Run the preamble from Section 4.2.2 IUT in Waiting For Next Block phase.

- Test Procedure

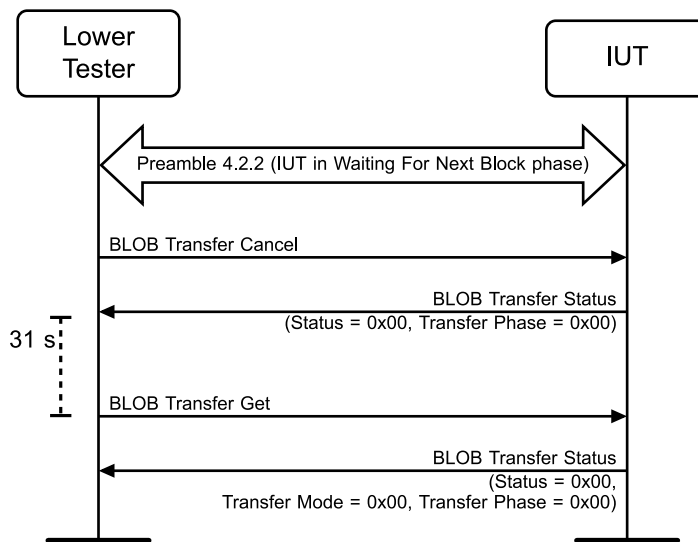

Figure 4.13: MBTM/SR/BT/BV-09-C [BLOB Transfer Cancel – IUT in Waiting For Next Block phase]

1. The Lower Tester sends a BLOB Transfer Cancel message to the IUT with the BLOB ID field set to Test BLOB ID.
2. The IUT responds with a BLOB Transfer Status message with the Status field set to 0x00 (Success), Transfer Mode is set to 0x00 (No Active Transfer), and Transfer Phase field set to 0x00 (Inactive).
3. After 31 s, the Lower Tester sends a BLOB Transfer Get message to the IUT.
4. The IUT responds with a BLOB Transfer Status message with the Status field set to 0x00 (Success), Transfer Mode is set to 0x00 (No Active Transfer), and Transfer Phase field set to 0x00 (Inactive).

- Expected Outcome



Pass verdict

The IUT responds with a BLOB Transfer Status message with the expected field values.

**MBTM/SR/BT/BV-10-C [Pull BLOB Transfer – Block Complete Timeout]**

## • Test Purpose

Verify that a BLOB Transfer server IUT times out the Block Complete timer on a BLOB transfer using the Pull BLOB Transfer mode.

## • Reference

[3] 5.2.4

## • Initial Condition

- If the IUT supports the Low Power feature, then a friendship is established between the IUT and an additional Lower Tester (acting as Friend node).
- After the friendship has been established, the IUT is set in the Waiting For Transfer Start phase by running the preamble procedure from Section 4.2.1.

## • Test Procedure



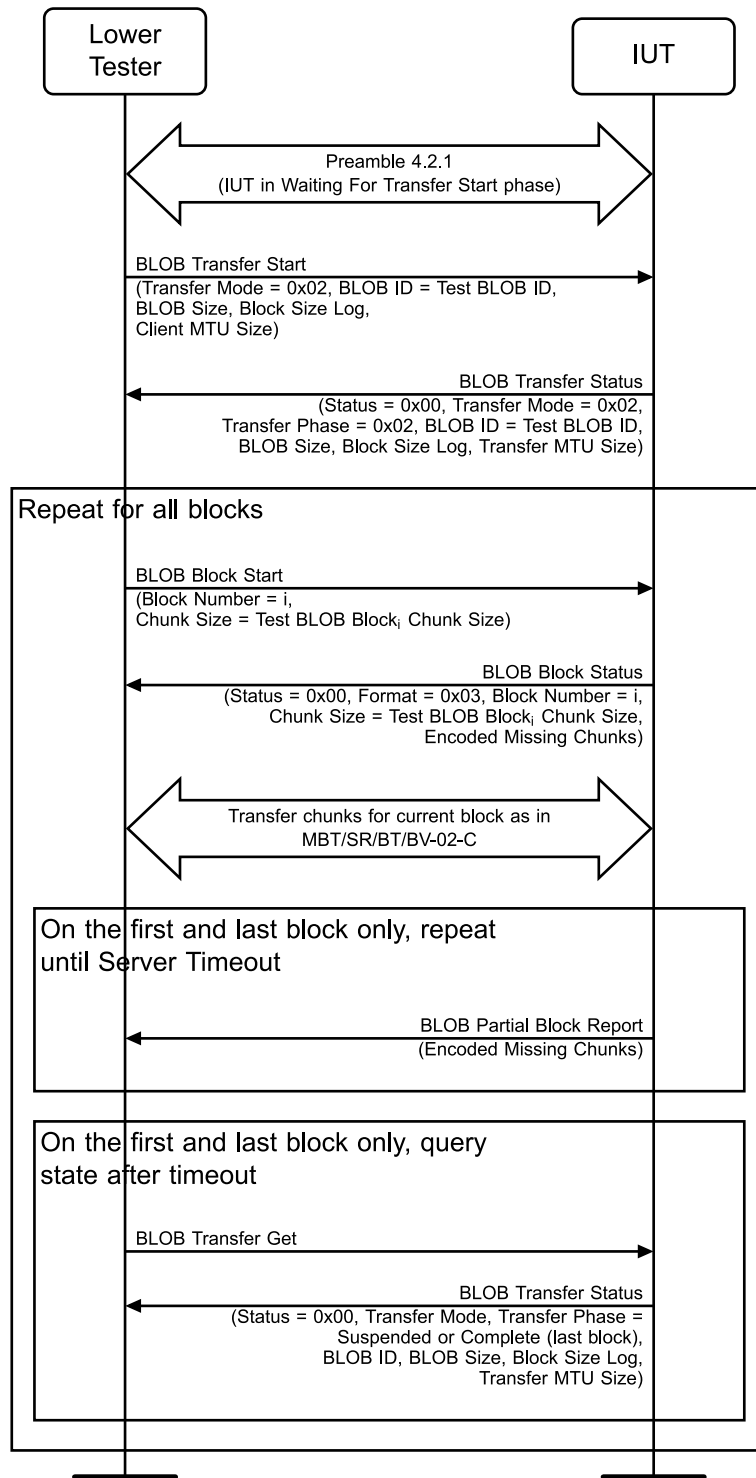

Figure 4.14: MBTM/SR/BT/BV-10-C [Pull BLOB Transfer - Block Complete Timeout]

1. The Lower Tester sends a BLOB Transfer Start message to the IUT with Transfer Mode set to 0x02 (Pull), BLOB ID set to Test BLOB ID, BLOB Size set to Test BLOB Size, Block Size Log set to Test Block Size Log, and Client MTU Size set to 0xFFFF.
2. The IUT sends a BLOB Transfer Status message with the Status field set to 0x00 (Success), Transfer Mode set to 0x02 (Pull), Transfer Phase field set to 0x02 (Waiting For Next Block), the BLOB ID, BLOB



Size, and Block Size Log fields set to the values from step 1, Transfer MTU Size set to a valid value, and the Blocks Not Received field of ceil (Test Block Count / 8) octets. The bitmask value has the least significant Test Block Count bits set to '1' and the rest set to '0'.

3. Execute the Transfer Block Sequence with Pull BLOB Transfer mode procedure in [MBTM/SR/BT/BV-02-C \[Transfer Block Sequence, Pull BLOB Transfer Mode\]](#) to transfer all chunks for the current block.
4. The Lower Tester does not send any further messages, and within 31 s since the last BLOB Partial Block Report, the IUT sends another BLOB Partial Block Report to the Lower Tester with the Encoded Missing Chunks field omitted.
5. Repeat step 4 until the server timeout expires. The interval between any two consecutive BLOB Partial Block Report messages is less than or equal to 31 s.
6. After the server timeout expires, the Lower Tester sends a BLOB Transfer Get message to the IUT.
7. The IUT sends a BLOB Transfer Status message with the Status field set to 0x00 (Success), Transfer Mode set to 0x02 (Pull), Transfer Phase field set to 0x05 (Suspended), BLOB ID set to Test BLOB ID, BLOB Size set to Test BLOB Size, Block Size Log set to Test Block Size Log, Transfer MTU Size set to a valid value, and the Blocks Not Received field of ceil (Test Block Count / 8) octets. Test Block Count has the least significant bit set to 0, the rest of the used bits set to 1, and the unused bits set to 0.
8. Repeat step 3 as many times as necessary to transfer all blocks, then repeat steps 4-7, but in step 7 the Transfer Phase field is expected to be set to "Complete" and the Test Block Count bits are all set to 0.

- Expected Outcome

Pass verdict

The IUT responds with BLOB Transfer Status messages with the expected field values.

In steps 4–5, The IUT sends a BLOB Partial Block Report with the expected field values at least every 31 s.

After step 5, the IUT sends no BLOB Partial Block Report messages.

The Transfer Phase field after a block timeout is set to Suspended if the block is not the last block, and it is set to Complete if the block is the last block.

### 4.3.1 Receive BLOB Transfer Cancel

- Test Purpose

Verify that when the IUT receives a BLOB Transfer Cancel message with acceptable fields, it responds with a BLOB Transfer Status message.

- Reference

[3] 5.3.3

- Initial Condition

- Use the initial condition described in [Table 4.2](#).

- Test Case Configuration



Test Case	Initial Condition
MBTM/SR/BT/BV-11-C [BLOB Transfer Cancel – IUT in Waiting for Transfer Start Phase]	Run preamble from Section 4.2.1, IUT in Waiting For Transfer Start Phase
MBTM/SR/BT/BV-12-C [BLOB Transfer Cancel – IUT in Waiting for Next Chunk Phase]	Run preamble from Section 4.2.3, IUT in Waiting For Next Chunk Phase
MBTM/SR/BT/BV-13-C [BLOB Transfer Cancel – IUT in Complete Phase, Push Transfer Mode]	Run steps 1-4 of test case MBTM/SR/BT/BV-01-C [Transfer Block Sequence, Push BLOB Transfer Mode]
MBTM/SR/BT/BV-14-C [BLOB Transfer Cancel – IUT in Complete Phase, Pull Transfer Mode]	Run steps 1–5 of test case MBTM/SR/BT/BV-02-C [Transfer Block Sequence, Pull BLOB Transfer Mode]
MBTM/SR/BT/BV-15-C [BLOB Transfer Cancel – IUT in Inactive Phase]	Run preamble from Section 4.2.4, IUT in Inactive Phase
MBTM/SR/BT/BV-16-C [BLOB Transfer Cancel – IUT in Suspended Phase]	Run preamble from Section 4.2.5, IUT in Suspended Phase, Block Number Unset

Table 4.2: Receive BLOB Transfer Cancel

• Test Procedure

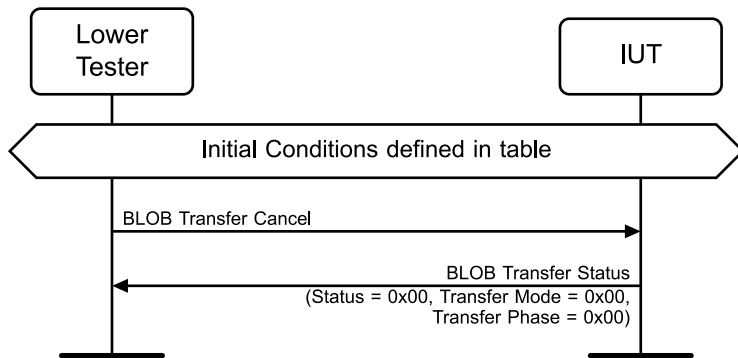

Figure 4.15: Receive BLOB Transfer Cancel

1. The Lower Tester sends a BLOB Transfer Cancel message to the IUT with the BLOB ID field set to Test BLOB ID.
2. The IUT responds with a BLOB Transfer Status message with the Status field set to 0x00 (Success), Transfer Mode is set to 0x00 (No Active Transfer), and Transfer Phase field set to 0x00 (Inactive).

• Expected Outcome

Pass verdict

The IUT responds with a BLOB Transfer Status message with the expected field values.

### 4.3.2 Receive BLOB Transfer Start

• Test Purpose



Verify that the IUT receives a BLOB Transfer Start message with acceptable fields and sends a BLOB Transfer Status message.

- Reference

[3] 5.3.2

- Initial Condition

- Use the initial condition described in [Table 4.3](#).

- Test Procedure

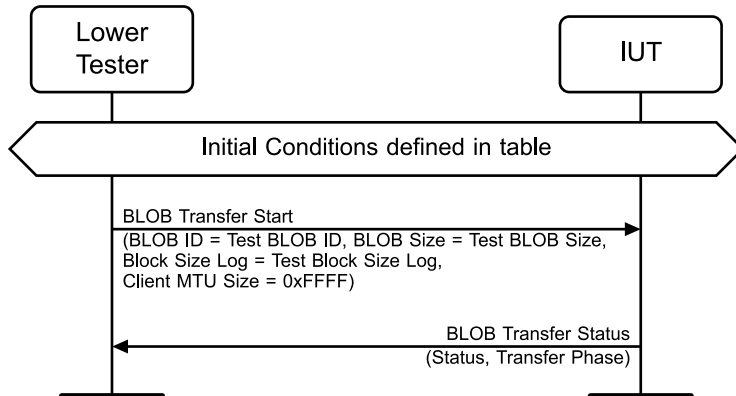

Figure 4.16: Receive BLOB Transfer Start

1. The Lower Tester sends a BLOB Transfer Start message to the IUT with Transfer Mode set to the value of the Transfer Mode state of the Lower Tester, BLOB ID set to Test BLOB ID, BLOB Size set to Test BLOB Size, Block Size Log set to Test Block Size Log, and Client MTU Size set to 0xFFFF.
2. The IUT sends a BLOB Transfer Status message with the Status field and the Transfer Phase field set to the values in [Table 4.3](#). If the Status field is 0x00 (Success), the message includes the Transfer Mode set to the value of the Transfer Mode state of the IUT, BLOB ID set to Test BLOB ID, BLOB Size set to Test BLOB Size, Block Size Log set to Test Block Size Log, Transfer MTU Size set to 0xFFFF, and Blocks Not Received field set to a valid value; otherwise, the message includes Transfer Mode set to 0x00 (No Active Transfer).

- Test Case Configuration

Test Case	Initial Condition	Status	Transfer Phase
<a href="#">MBTM/SR/BT/BV-17-C [BLOB Transfer Start – IUT in Waiting for Next Block Phase]</a>	Run preamble from Section 4.2.2, IUT in Waiting For Next Block Phase	0x00 (Success)	0x02 (Waiting For Next Block)
<a href="#">MBTM/SR/BT/BV-18-C [BLOB Transfer Start – IUT in Waiting for Next Chunk Phase]</a>	Run preamble from Section 4.2.3, IUT in Waiting For Next Chunk Phase	0x00 (Success)	0x03 (Waiting For Next Chunk)
<a href="#">MBTM/SR/BT/BV-19-C [BLOB Transfer Start – IUT in Complete Phase, Push Transfer Mode]</a>	Run test case <a href="#">MBTM/SR/BT/BV-04-C [BLOB Transfer Procedure, Push BLOB Transfer Mode]</a>	0x00 (Success)	0x04 (Complete)
<a href="#">MBTM/SR/BT/BV-20-C [BLOB Transfer Start – IUT in Complete Phase, Pull Transfer Mode]</a>	Run test case <a href="#">MBTM/SR/BT/BV-05-C [BLOB Transfer Procedure, Pull BLOB Transfer Mode]</a>	0x00 (Success)	0x04 (Complete)
<a href="#">MBTM/SR/BT/BV-21-C [BLOB Transfer Start – IUT in Suspended Phase]</a>	Run preamble from Section 4.2.5, IUT in Suspended Phase, Block Number Unset	0x00 (Success)	0x02 (Waiting For Next Block)
<a href="#">MBTM/SR/BT/BV-22-C [BLOB Transfer Start – IUT in Inactive Phase]</a>	Run preamble from Section 4.2.4, IUT in Inactive Phase	0x04 (Wrong Phase)	0x00 (Inactive)

Table 4.3: Receive BLOB Transfer Start

- Expected Outcome

Pass verdict

The IUT responds with a BLOB Transfer Status message with the expected field values.

### 4.3.3 Receive BLOB Block Start

- Test Purpose

Verify that the IUT receives a BLOB Block Start message with acceptable fields and sends a BLOB Block Status message.

- Reference

[3] 5.3.6

- Initial Condition

- Use the initial condition described in [Table 4.4](#).
- If the IUT is in the Waiting For Next Chunk phase, the block number  $i$  used by the Lower Tester is set to 0; otherwise, it is set to a random value inside the half-open interval  $[0, \text{Test Block Count})$ .  $n$  is set to the value of Test Block Count – 1.



- Test Case Configuration

Test Case	Initial Condition	Step 2
MBTM/SR/BT/BV-23-C [BLOB Block Start – IUT in Waiting for Transfer Start Phase]	Run preamble from Section 4.2.1, IUT in Waiting For Transfer Start Phase	Status = 0x04 (Wrong Phase) Format = 0x0 (All Chunks Missing) Block Number = 0xFFFF Chunk Size = 0xFFFF
MBTM/SR/BT/BV-24-C [BLOB Block Start – IUT in Waiting for Next Chunk Phase]	Run preamble from Section 4.2.3, IUT in Waiting For Next Chunk Phase	Status = 0x00 (Success) Format = 0x0 (All Chunks Missing) Block Number = i Chunk Size = Test BLOB Block <sub>i</sub> Chunk Size
MBTM/SR/BT/BV-25-C [BLOB Block Start – IUT in Complete Phase, Push Transfer Mode]	Run test case MBTM/SR/BT/BV-01-C [Transfer Block Sequence, Push BLOB Transfer Mode]	Status = 0x00 (Success) Format = 0x1 (No Missing Chunks) Block Number = n Chunk Size = Test BLOB Block <sub>n</sub> Chunk Size
MBTM/SR/BT/BV-26-C [BLOB Block Start – IUT in Complete Phase, Pull Transfer Mode]	Run test case MBTM/SR/BT/BV-02-C [Transfer Block Sequence, Pull BLOB Transfer Mode]	Status = 0x00 (Success) Format = 0x3 (Encoded Missing Chunks) Block Number = n Chunk Size = Test BLOB Block <sub>n</sub> Chunk Size
MBTM/SR/BT/BV-27-C [BLOB Block Start – IUT in Suspended Phase, Block Number Set]	Run preamble from Section 4.2.6, IUT in Suspended Phase, Block Number Set	Status = 0x00 (Success) Format = 0x0 (All Chunks Missing) Block Number = i Chunk Size = Test BLOB Block <sub>i</sub> Chunk Size
MBTM/SR/BT/BV-28-C [BLOB Block Start – IUT in Suspended Phase, Block Number Unset]	Run preamble from Section 4.2.5, IUT in Suspended Phase, Block Number Unset	Status = 0x00 (Success) Format = 0x0 (All Chunks Missing) Block Number = i Chunk Size = Test BLOB Block <sub>i</sub> Chunk Size
MBTM/SR/BT/BV-29-C [BLOB Block Start – IUT in Inactive Phase]	Run preamble from Section 4.2.4, IUT in Inactive Phase	Status = 0x04 (Wrong Phase) Format = 0x0 (All Chunks Missing) Block Number = 0xFFFF Chunk Size = 0xFFFF

Table 4.4: Receive BLOB Block Start test cases

- Test Procedure



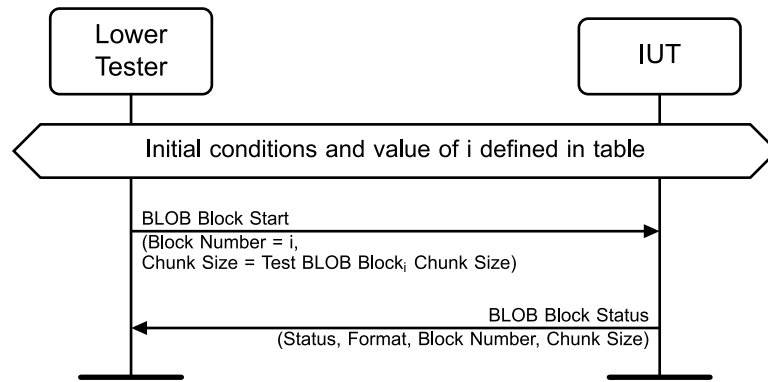

Figure 4.17: Receive BLOB Block Start

1. The Lower Tester sends a BLOB Block Start message to the IUT with Block Number field and Chunk Size field set as defined in [Table 4.4](#).
2. The IUT sends a BLOB Block Status message with the Status, Format, Block Number, and Chunk Size fields set to the corresponding values from [Table 4.4](#). All RFU field bits are set to '0'.

- Expected Outcome

Pass verdict

The IUT responds with a BLOB Block Status message with the expected field values.

### MBTM/SR/BT/BV-30-C [BLOB Transfer Start – Incompatible Parameters]

- Test Purpose

Verify that the IUT rejects a BLOB Transfer Start message with unacceptable fields and sends a BLOB Transfer Status message with a failure status code.

- Reference

[3] 5.3.2

- Initial Condition

- The IUT is set in the Waiting For Transfer Start phase by running the preamble procedure from [Section 4.2.1](#).

- Test Procedure

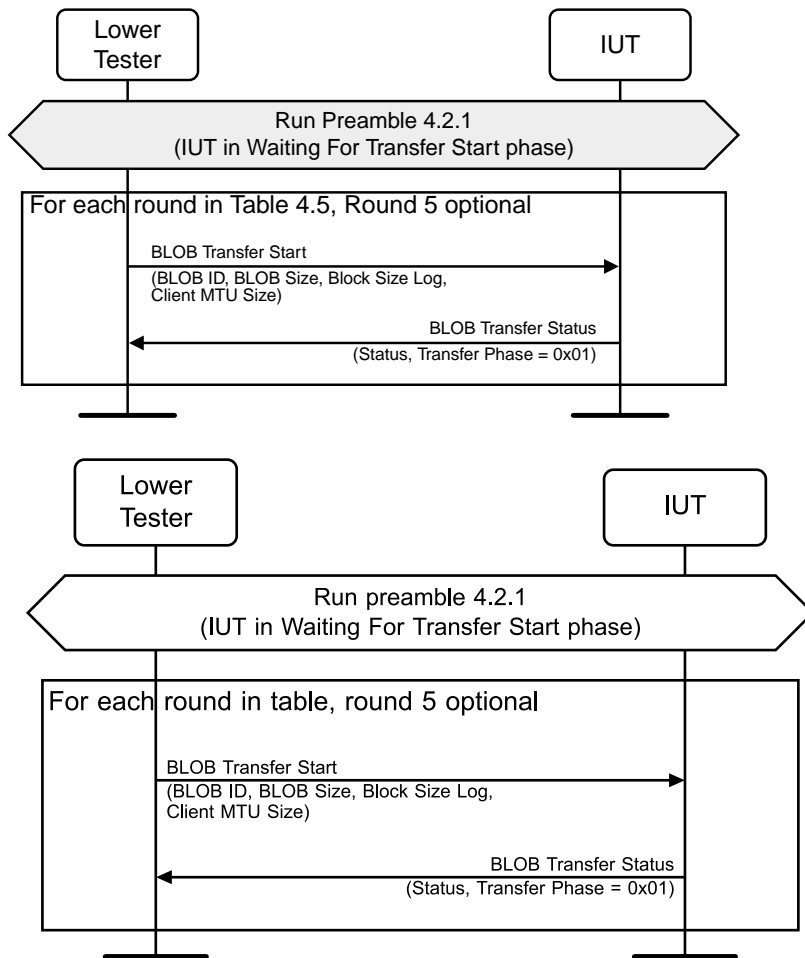

Figure 4.18: MBTM/SR/BT/BV-30-C [BLOB Transfer Start – Incompatible Parameters]

Repeat steps for each round in [Table 4.5](#).

If Max BLOB Size  $\leq$  (Test Max Block Count + 1)  $\times$   $2^{\text{Min Block Size Log}}$ , skip round 5.

1. The Lower Tester sends a BLOB Transfer Start message to the IUT with the fields set to random values as specified in [Table 4.5](#), otherwise with Transfer Mode set to the value of the Transfer Mode state of the Lower Tester, BLOB ID set to Test BLOB ID, BLOB Size set to Test BLOB Size, Block Size Log set to Test Block Size Log, and Client MTU Size set to 0x0014.
2. The IUT sends a BLOB Transfer Status message with the Status field set to the values specified in [Table 4.5](#), Transfer Mode set to 0x00 (No Active Transfer), and the Transfer Phase field set to 0x01 (Waiting For Transfer Start).

Round	BLOB Transfer Start fields	Status
1	BLOB ID $\neq$ Test BLOB ID	0x06 (Wrong BLOB ID)
2	BLOB Size > Max BLOB Size	0x07 (BLOB Too Large)
3	Block Size Log > Max Block Size Log	0x02 (Invalid Block Size)
4	Block Size Log < Min Block Size Log	0x02 (Invalid Block Size)
5	Test Block Size Log = Min Block Size Log BLOB Size = (Test Max Block Count + 1) $\times 2^{\text{Min Block Size Log}}$	0x05 (Invalid Parameter)
6 (skip if IUT supports all transfer modes)	Transfer Mode set to a value that corresponds to a Supported Transfer Mode state the IUT does not support.	0x08 (Unsupported Transfer Mode)

Table 4.5: Test round parameters for MBTM/SR/BT/BV-30-C

- Expected Outcome

Pass verdict

The IUT responds with a BLOB Transfer Status message with the expected field values.

### MBTM/SR/BT/BV-31-C [BLOB Transfer Start – Invalid Parameters]

- Test Purpose

Verify that the IUT rejects a BLOB Transfer Start message with unacceptable fields and sends a BLOB Transfer Status message with a failure status code when the transfer is active.

- Reference

[3] 5.3.2

- Initial Condition

- The IUT is set in Waiting For Next Block phase by running the preamble procedure from Section 4.2.2.

- Test Procedure



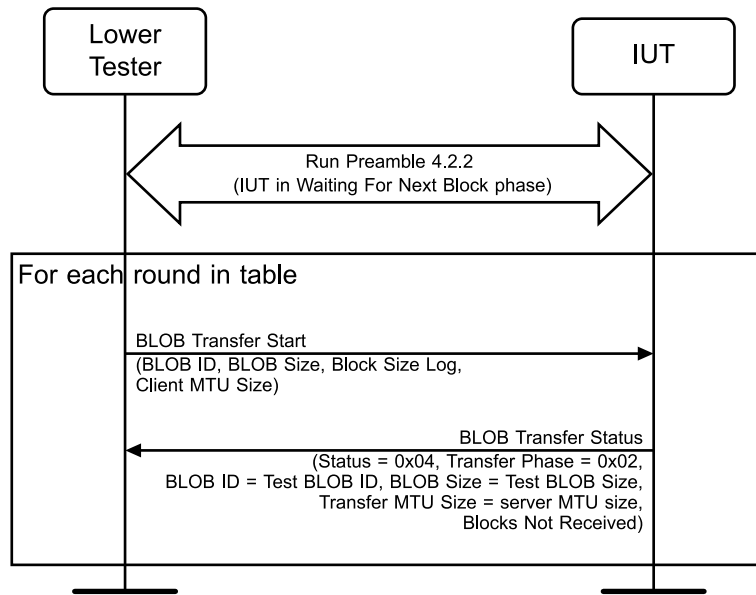

Figure 4.19: MBTM/SR/BT/BV-31-C [BLOB Transfer Start – Invalid Parameters]

Repeat steps for each round in Table 4.6:

1. The Lower Tester sends a BLOB Transfer Start message to the IUT with the parameters set to random valid values as specified in Table 4.6, otherwise with Transfer Mode set to the value of the Transfer Mode state of the Lower Tester, BLOB ID set to Test BLOB ID, BLOB Size set to Test BLOB Size, Block Size Log set to Test Block Size Log, and Client MTU Size set to 0xFFFF.
2. The IUT sends a BLOB Transfer Status message with the Status field set to 0x04 (Wrong Phase), Transfer Mode set to the value of the Transfer Mode state of the IUT, Transfer Phase field set to 0x02 (Waiting For Next Block), BLOB ID set to Test BLOB ID, BLOB Size set to Test BLOB Size, Block Size Log set to Test Block Size Log, Transfer MTU Size set to the server MTU size, and the Blocks Not Received field of ceil (Test Block Count / 8) octets. The bitmask value has the least significant Test Block Count bits set to '1' and the rest set to '0'.

Round	BLOB Transfer Start fields
1	BLOB Size ≠ Test BLOB Size, BLOB Size > Max BLOB Size
2	Block Size Log ≠ Test Block Size Log
3	Transfer MTU Size ≠ 0xFFFF

Table 4.6: Test round parameters for MBTM/SR/BT/BV-31-C

- Expected Outcome

Pass verdict

The IUT responds with a BLOB Transfer Status message with the expected field values.

### MBTM/SR/BT/BV-32-C [BLOB Transfer Cancel – Invalid Parameters]



- Test Purpose

Verify that the IUT rejects a BLOB Transfer Cancel message with unacceptable fields and sends a BLOB Transfer Status message with a failure status code.

- Reference

[3] 5.3.3

- Initial Condition

- The IUT is set in Waiting For Next Block phase by running the preamble procedure from Section 4.2.2.

- Test Procedure

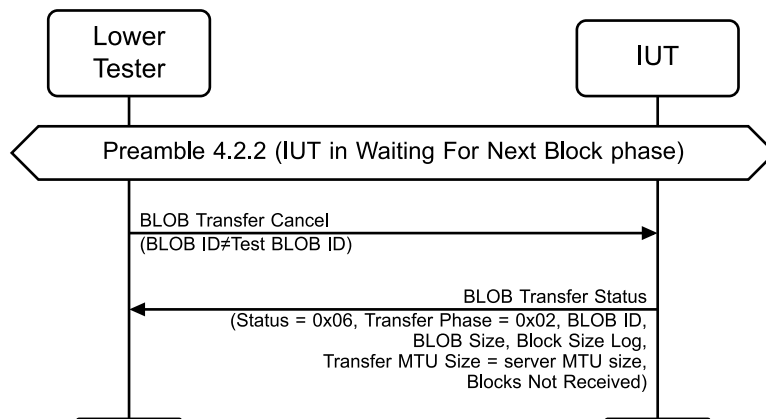

Figure 4.20: MBTM/SR/BT/BV-32-C [BLOB Transfer Cancel – Invalid Parameters]

1. The Lower Tester sends a BLOB Transfer Cancel message to the IUT with the BLOB ID field set to a value other than the Test BLOB ID.
2. The IUT sends a BLOB Transfer Status message with the Status field set to 0x06 (Wrong BLOB ID), Transfer Mode set to the value of the Transfer Mode state of the IUT, the Transfer Phase field set to 0x02 (Waiting For Next Block), the BLOB ID, BLOB Size, and Block Size Log fields set to the values from step 1, Transfer MTU Size set to server MTU size, and the Blocks Not Received field of ceil (Test Block Count / 8) octets. The bitmask value has the least significant Test Block Count bits set to '1' and the rest set to '0'. All RFU field bits are set to '0'.

- Expected Outcome

Pass verdict

The IUT responds with a BLOB Transfer Status message with the expected field values.

### MBTM/SR/BT/BV-33-C [BLOB Block Start – Invalid Parameters]

- Test Purpose

Verify that the IUT rejects a BLOB Block Start message with unacceptable fields and sends a BLOB Block Status message with a failure status code.

- Reference

[3] 5.3.6

- Initial Condition

- The IUT is set in Waiting For Next Block phase by running the preamble procedure from Section 4.2.2.

- Test Procedure

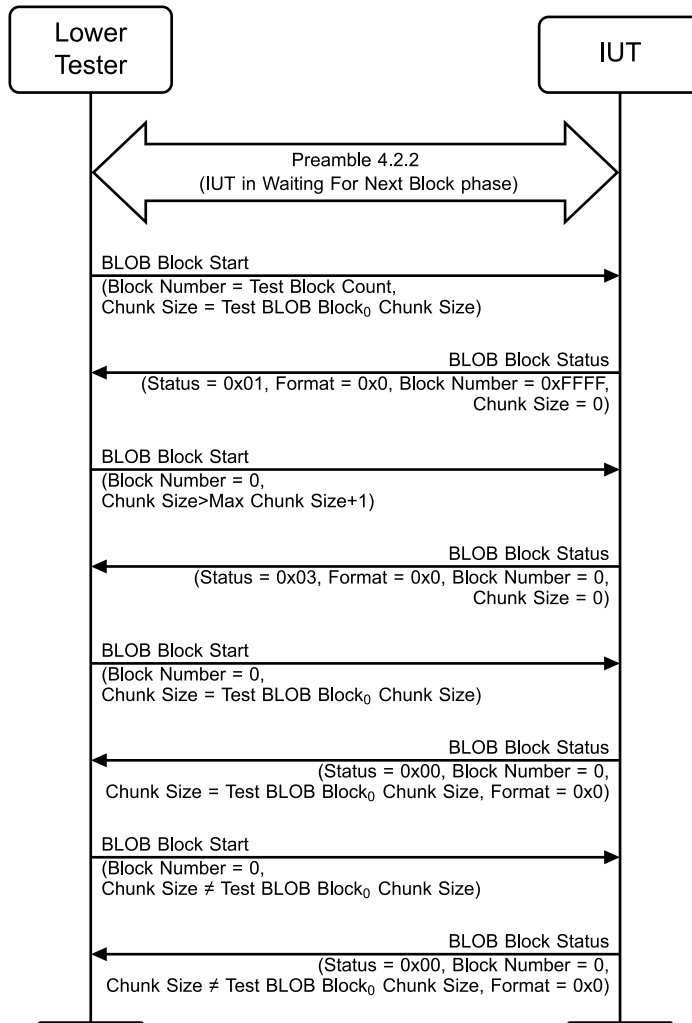

Figure 4.21: MBTM/SR/BT/BV-33-C [BLOB Block Start – Invalid Parameters]

1. The Lower Tester sends a BLOB Block Start message to the IUT with Block Number field set to Test Block Count and Chunk Size field set to Test BLOB Block<sub>0</sub> Chunk Size.
2. The IUT sends a BLOB Block Status message with the Status field set to 0x01 (Invalid Block Number), Format field is set to 0x0 (All Chunks Missing), Block Number field set to 0xFFFF, and the Chunk Size field set to 0. All RFU field bits are set to '0'.
3. The Lower Tester sends a BLOB Block Start message to the IUT with Block Number field set to 0 and Chunk Size field set to a value greater than Max Chunk Size + 1.
4. The IUT sends a BLOB Block Status message with the Status field set to 0x03 (Invalid Chunk Size) Format field is set to 0x0 (All Chunks Missing), Block Number field set to 0, and the Chunk Size field



set to 0. All RFU field bits are set to '0'.

5. The Lower Tester sends a BLOB Block Start message to the IUT with Block Number field set to 0 and Chunk Size field set to Test BLOB Block<sub>0</sub> Chunk Size.
6. The IUT sends a BLOB Block Status message with the Status field set to 0x00 (Success), Block Number field set to 0, Chunk Size field set to Test BLOB Block<sub>0</sub> Chunk Size, and the Format field set to 0x0 (All Chunks Missing). All RFU field bits are set to '0'.
7. Repeat steps 5–6 where in step 5 Block Number is set to 0 and Chunk Size is set to a value other than Test BLOB Block<sub>0</sub> Chunk Size.

- Expected Outcome

Pass verdict

The IUT responds with a BLOB Block Status message with the expected field values.

**MBTM/SR/BT/BV-34-C [BLOB Chunk Transfer – Invalid Parameters]**

- Test Purpose

Verify that the IUT ignores a BLOB Chunk Transfer message with unacceptable fields.

- Reference

[3] 5.3.9

- Initial Condition

- The IUT is set up in the Waiting For Next Chunk phase by running the preamble in Section 4.2.3.

- Test Procedure

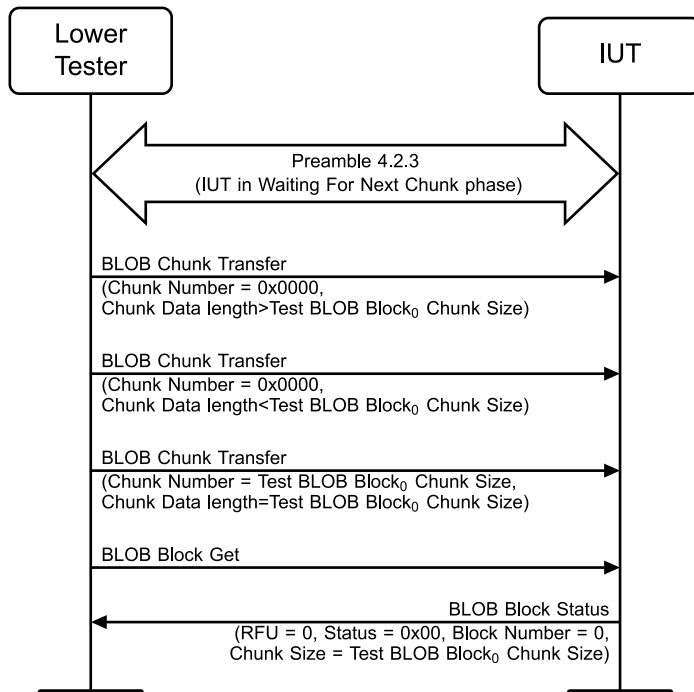

Figure 4.22: MBTM/SR/BT/BV-34-C [BLOB Chunk Transfer – Invalid Parameters]



1. The Lower Tester sends a segmented BLOB Chunk Transfer message to the IUT with the Chunk Number field set to the 0x0000 and Chunk Data set to an array of random values and of length greater than Test BLOB Block<sub>0</sub> Chunk Size.
2. The Lower Tester sends a segmented BLOB Chunk Transfer message to the IUT with the Chunk Number field set to the 0x0000 and Chunk Data set to an array of random values and of length smaller than Test BLOB Block<sub>0</sub> Chunk Size.
3. The Lower Tester sends a segmented BLOB Chunk Transfer message to the IUT with the Chunk Number field set to Test BLOB Block<sub>0</sub> Chunk Count and Chunk Data set to an array of random values and of length Test BLOB Block<sub>0</sub> Chunk Size.
4. The Lower Tester sends a BLOB Block Get message to the IUT.
5. The IUT sends a BLOB Block Status message with the RFU field set to 0 and the Status field set to 0x00 (Success), Block Number field set to 0, and the Chunk Size field set to Test BLOB Block<sub>0</sub> Chunk Size. All RFU field bits are set to '0'.

- Expected Outcome

Pass verdict

The IUT responds with a BLOB Block Status message with the expected field values.

### **MBTM/SR/BT/BV-35-C [BLOB Transfer Server State – Default Values]**

- Test Purpose

Verify that the BLOB Transfer Server IUT sets the states to the correct default values.

- Reference

[3] 3.2

- Initial Condition

- The IUT has been provisioned and did not take part in any BLOB transfer procedure.

- Test Procedure



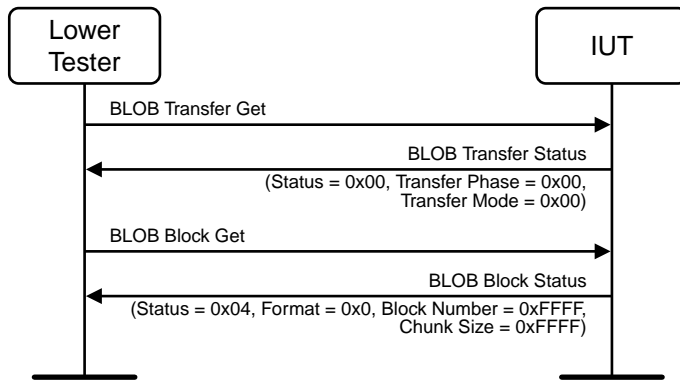

Figure 4.23: MBTM/SR/BT/BV-35-C [BLOB Transfer Server State – Default Values]

1. The Lower Tester sends a BLOB Transfer Get message to the IUT.
2. The IUT responds with a BLOB Transfer Status message with the Status field set to 0x00 (Success), Transfer Phase set to 0x00 (Inactive), and Transfer Mode set to 0x00 (No Active Transfer).
3. The Lower Tester sends a BLOB Block Get message to the IUT.
4. The IUT sends a BLOB Block Status message with the RFU field set to 0 and the Status field set to 0x04 (Wrong Phase), Format set to 0x0 (All Chunks Missing), Block Number field set to 0xFFFF, and the Chunk Size field set to 0xFFFF. All RFU field bits are set to '0'.

- Expected Outcome

#### Pass verdict

The IUT responds with a BLOB Transfer Status and a BLOB Block Status message with the expected field values and Transfer TTL set to the value indicated by Default TTL state.

### 4.3.4 Receive BLOB Block Get

- Test Purpose

Verify that the IUT receives a BLOB Block Get message with acceptable fields and sends a BLOB Block Status message.

- Reference

[3] 5.3.5

- Initial Condition

- Use the initial condition as described in [Table 4.7](#).

- Test Case Configuration

Test Case	Initial Condition	Status
<a href="#">MBTM/SR/BT/BV-36-C [BLOB Block Get – IUT in Waiting for Transfer Start Phase]</a>	Run preamble from Section 4.2.1, IUT in Waiting For Transfer Start Phase	0x04 Wrong Phase)
<a href="#">MBTM/SR/BT/BV-37-C [BLOB Block Get – IUT in Suspended Phase]</a>	Run preamble from Section 4.2.5, IUT in Suspended Phase, Block Number Unset	0x0A (Information Unavailable)
<a href="#">MBTM/SR/BT/BV-38-C [BLOB Block Get – IUT in Inactive Phase]</a>	Run preamble from Section 4.2.4, IUT in Inactive Phase	0x04 (Wrong Phase)

Table 4.7: Receive BLOB Block Get test cases

• Test Procedure

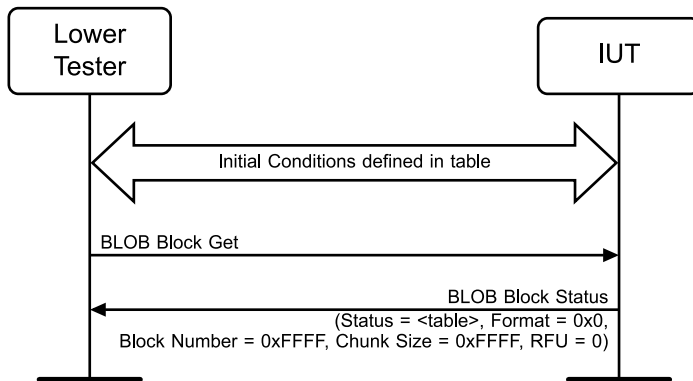

Figure 4.24: Receive BLOB Block Get

1. The Lower Tester sends a BLOB Block Get message to the IUT.
2. The IUT sends a BLOB Block Status message with the Status set to the value indicated in [Table 4.7](#), Format set to 0x0 (All Chunks Missing), Block Number set to 0xFFFF, and Chunk Size set to 0xFFFF. All RFU field bits are set to '0'.

• Expected Outcome

Pass verdict

The IUT responds with a BLOB Block Status message with the expected field values.

**MBTM/SR/BT/BI-01-C [BLOB Transfer Start – RFU Bits]**

• Test Purpose

Verify that the IUT receives a BLOB Transfer Start message with RFU fields set and sends a BLOB Transfer Status message.

• Reference

[3] 4.2

• Initial Condition



- The IUT is set in the Waiting For Transfer Start phase by running the preamble procedure from Section 4.2.1.

- Test Procedure

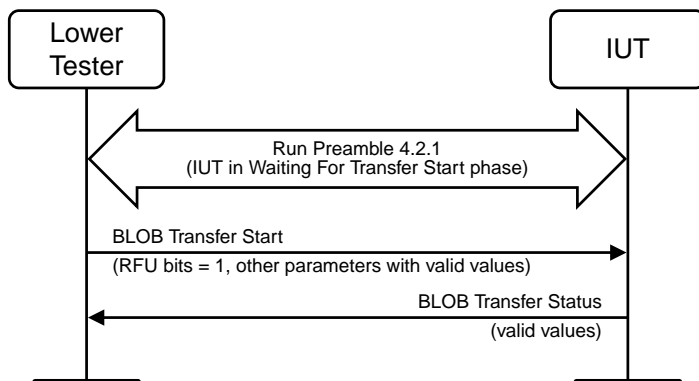

Figure 4.25: MBTM/SR/BT/BI-01-C [BLOB Transfer Start – RFU Bits]

1. The Lower Tester sends a BLOB Transfer Start message to the IUT with RFU bits set to '1', Transfer Mode set to the value of the Transfer Mode state of the Lower Tester, BLOB ID set to Test BLOB ID, BLOB Size set to Test BLOB Size, Block Size Log set to Test Block Size Log, and Client MTU Size set to 0xFFFF.
2. The IUT sends a BLOB Transfer Status message with the Status field set to 0x00 (Success), Transfer Mode set as in step 1, Transfer Phase field set to 0x02 (Waiting For Next Block), the BLOB ID, BLOB Size, and Block Size Log fields set to the values from step 1, Transfer MTU Size set to 0xFFFF, and the Blocks Not Received field of ceil (Test Block Count / 8) octets. The bitmask value has the least significant Test Block Count bits set to '1' and the rest set to '0'.

- Expected Outcome

Pass verdict

The IUT responds with a BLOB Transfer Status message with the expected field values.

### MBTM/SR/BT/BI-02-C [BLOB Transfer Start – Prohibited Transfer Mode]

- Test Purpose

Verify that the IUT ignores a BLOB Transfer Start message with a prohibited transfer mode.

- Reference

[3] 4.2

- Initial Condition

- The IUT is set in the Waiting For Transfer Start phase by running the preamble procedure from Section 4.2.1.

- Test Procedure



1. The Lower Tester sends a BLOB Transfer Start message to the IUT with Transfer Mode set to 0x03, BLOB ID set to Test BLOB ID, BLOB Size set to Test BLOB Size, Block Size Log set to Test Block Size Log, and Client MTU Size set to 0xFFFF.
2. The IUT does not send any BLOB Transfer Status messages.

- Expected Outcome

Pass verdict

The IUT does not respond with a BLOB Transfer Status message.

## 4.4 BLOB Transfer Client

This test group verifies the BLOB Transfer Client model procedures and behaviors.

### MBTM/CL/BT/BV-01-C [Transfer BLOB Procedure, Push BLOB Transfer Mode]

- Test Purpose

Verify that the IUT can transfer a BLOB to an active receiver device.

- Reference

[3] 6.2.3

- Initial Condition

- The test BLOB is defined in the IXIT [5] by TSPX\_Client\_BLOB\_ID and TSPX\_Client\_BLOB\_Data.

- Test Procedure



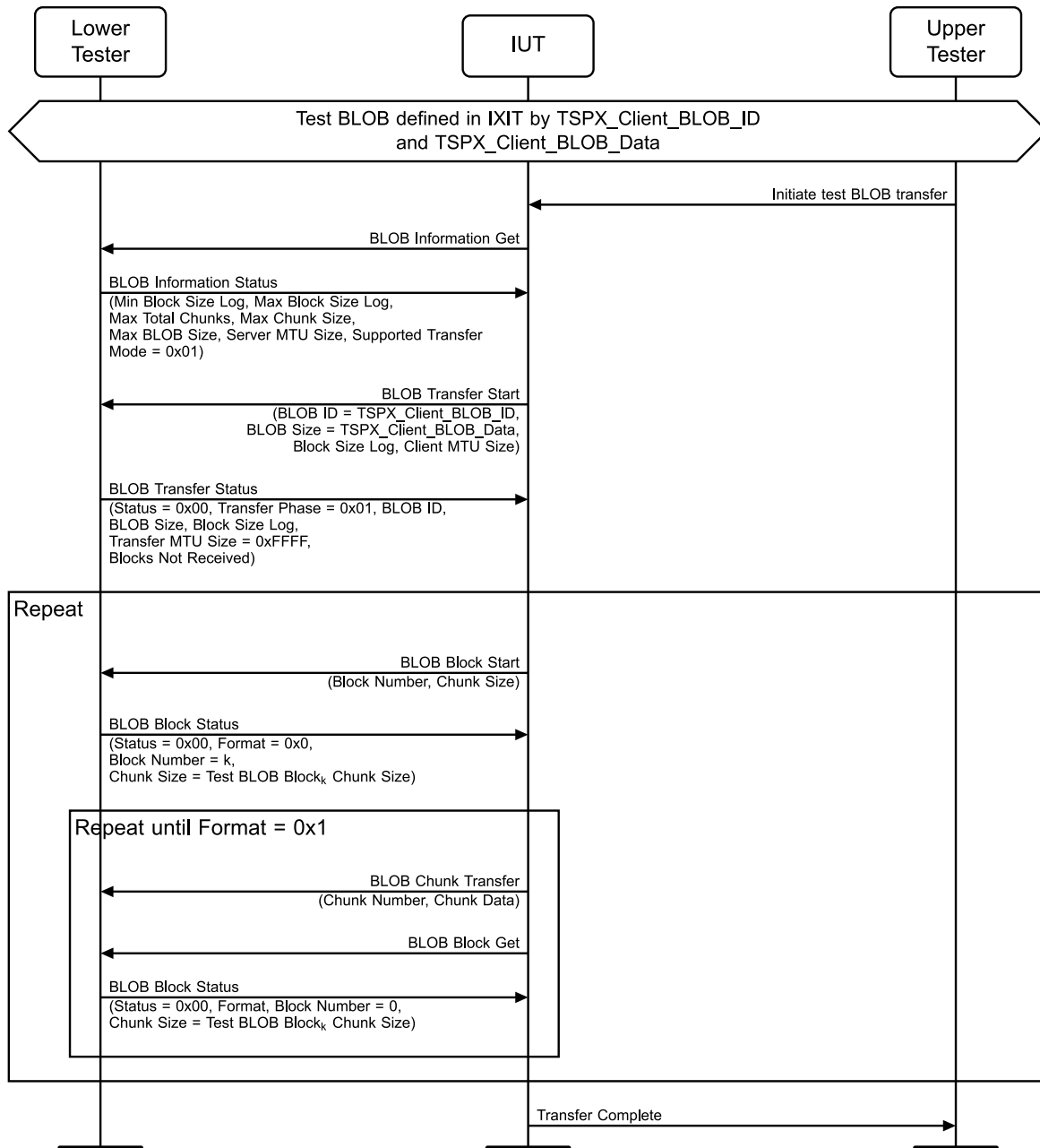

Figure 4.26: MBTM/CL/BT/BV-01-C [Transfer BLOB Procedure, Push BLOB Transfer Mode]

1. The Upper Tester orders the IUT to initiate the transfer of the test BLOB to the Lower Tester by using a valid value for the Transfer TTL.
2. The IUT sends a BLOB Information Get message.
3. The Lower Tester responds with a BLOB Information Status message with the Min Block Size Log, Max Block Size Log, Max Total Chunks, Max Chunk Size, Max BLOB Size, Server MTU Size, and Supported Transfer Mode fields set to 0x01 (Push).
4. The IUT sends a BLOB Transfer Start message with Transfer Mode set to 0x01 (Push), BLOB ID and BLOB Size set to the TSPX\_Client\_BLOB\_ID and size of TSPX\_Client\_BLOB\_Data, Block Size Log set to a valid value in the closed interval [Min Block Size Log, Max Block Size Log], and Client MTU Size set to a valid value. All RFU field bits are set to '0'.



5. The Lower Tester responds with a BLOB Transfer Status message with the Status field set to 0x00 (Success), Transfer Mode set to 0x01 (Push), Transfer Phase field set to 0x01 (Waiting For Next Block), the BLOB ID, BLOB Size, and Block Size Log fields set to the values from step 4, Transfer MTU Size set to 0xFFFF, and the Blocks Not Received field set to a valid value.
6. The IUT sends a BLOB Block Start message to the IUT with Block Number field set to a value in the closed interval  $[0, \text{ceil}(\text{BLOB Size} / 2^{\text{Block Size Log}})]$  and Chunk Size field set to a valid value. The Lower Tester stores the Block Number value as  $k$ .
7. The Lower Tester responds with a BLOB Block Status message with the Status field set to 0x00 (Success), Format field set to 0x0 (All Chunks Missing), Block Number field set to  $k$ , and the Chunk Size field set to Test BLOB Block $_k$  Chunk Size.
8. The IUT sends  $(2^{\text{Block Size Log}} / \text{Chunk Size})$  BLOB Chunk Transfer messages with the Chunk Number field set to consecutive values in the open interval  $(0, 2^{\text{Block Size Log}} / \text{Chunk Size} - 1)$  and Chunk Data set to an array of values of length equal to the Chunk Size field from step 7, except for the last chunk which may be smaller.
9. The IUT sends a BLOB Block Get message to the Lower Tester.
10. The Lower Tester responds with a BLOB Block Status message with the Status field set to 0x00 (Success), Format field set to 0x1 (No Missing Chunks) or 0x02 (Some Chunks Missing), Block Number field set to 0, Chunk Size field set to Test BLOB Block $_k$  Chunk Size, and Missing Chunks field set to the corresponding value if the Format field is set to 0x02.
11. Repeat steps 8–10 until the Lower Tester responds in step 10 with a BLOB Block Status message with Format field set to 0x1 (No Missing Chunks). In step 8, the IUT may send only the missing chunks reported by the Lower Tester in step 10.
12. Repeat steps 6–11 for each remaining block number in the closed interval  $[0, \text{ceil}(\text{BLOB Size} / 2^{\text{Block Size Log}})]$ .
13. The Lower Tester checks if the BLOB Data matches the value declared in TSPX\_Client\_BLOB\_Data.

- Expected Outcome

Pass verdict

The IUT transfers the test BLOB from TSPX\_Client\_BLOB\_Data to the Lower Tester.

The messages sent by the IUT are using the Transfer TTL specified by the Upper Tester.

The IUT signals the Upper Tester that the transfer is complete.

## MBTM/CL/BT/BV-02-C [Transfer BLOB Procedure, Pull BLOB Transfer Mode]

- Test Purpose

Verify that the IUT can transfer a BLOB to an active receiver device.

- Reference

[3] 6.2.3

- Initial Condition

- The test BLOB is defined in the IXIT [5] by TSPX\_Client\_BLOB\_ID and TSPX\_Client\_BLOB\_Data.



• Test Procedure

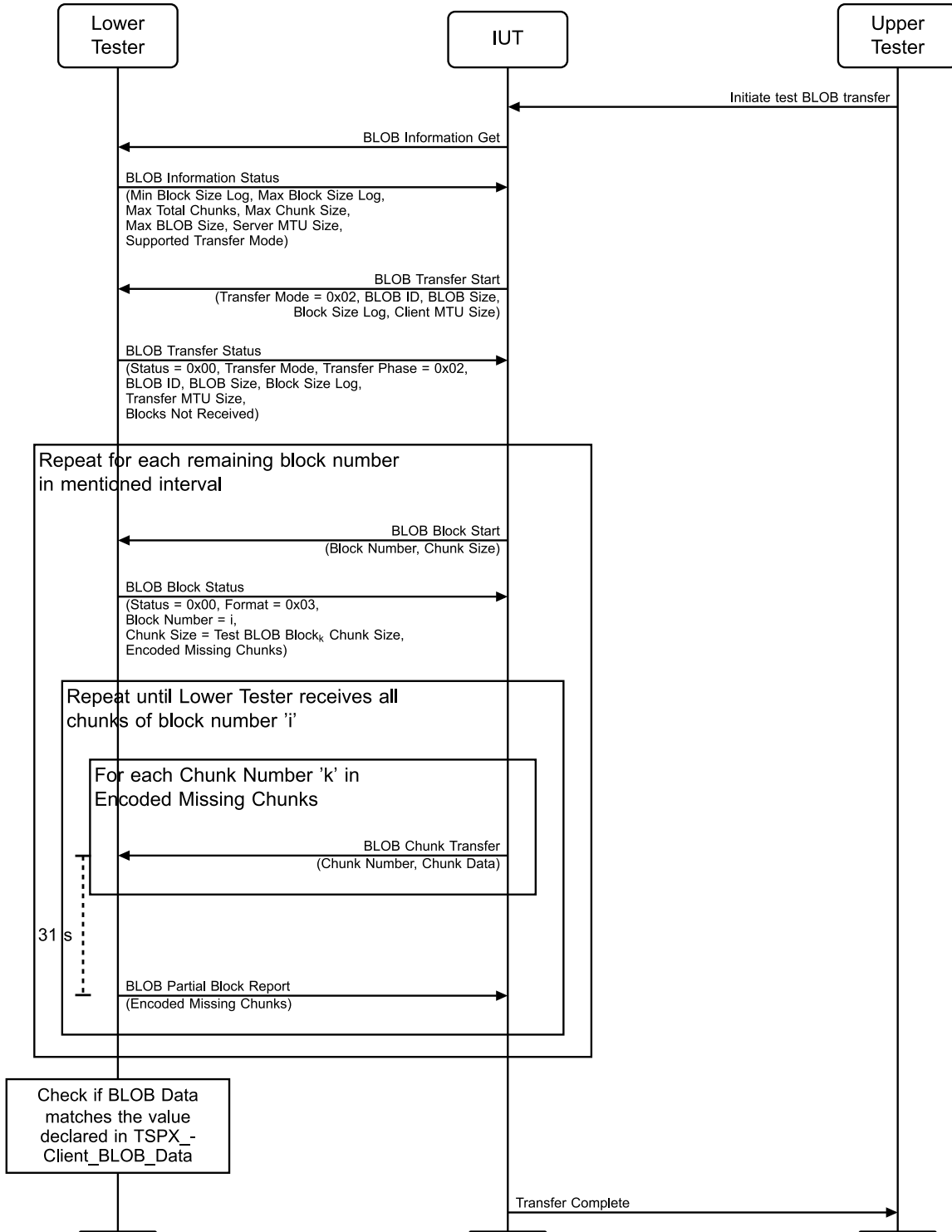

Figure 4.27: MBTM/CL/BT/BV-02-C [Transfer BLOB Procedure, Pull BLOB Transfer Mode]

1. The Upper Tester orders the IUT to initiate the transfer of the test BLOB to the Lower Tester by using a valid value for the Transfer TTL.



2. The IUT sends a BLOB Information Get message.
3. The Lower Tester responds with a BLOB Information Status message with the Min Block Size Log, Max Block Size Log, Max Total Chunks, Max Chunk Size, Max BLOB Size, Server MTU Size, and Supported Transfer Mode fields set to 0x02 (Pull).
4. The IUT sends a BLOB Transfer Start message with Transfer Mode set to 0x02 (Pull), BLOB ID and BLOB Size set to the TSPX\_Client\_BLOB\_ID and size of TSPX\_Client\_BLOB\_Data, Block Size Log set to a valid value in the closed interval [Min Block Size Log, Max Block Size Log], and Client MTU Size set to a valid value. All RFU field bits are set to '0'.
5. The Lower Tester responds with a BLOB Transfer Status message with the Status field set to 0x00 (Success), Transfer Mode set to 0x02 (Pull), Transfer Phase field set to 0x02 (Waiting For Next Block), the BLOB ID, BLOB Size, and Block Size Log fields set to the values from step 4, Transfer MTU Size set to 0xFFFF, and the Blocks Not Received field set to a valid value.
6. The IUT sends a BLOB Block Start message to the IUT with Block Number field set to a value in the closed interval  $[0, \text{ceil}(\text{BLOB Size} / 2^{\text{Block Size Log}})]$  and Chunk Size field set to a valid value. The Lower Tester stores the Block Number value as 'i'.
7. The Lower Tester responds with a BLOB Block Status message with the Status field set to 0x00 (Success), Format field is set to 0x03 (Encoded Missing Chunks), Block Number field set to 'i', and the Chunk Size field set to Test BLOB Block<sub>k</sub> Chunk Size, and Encoded Missing Chunks set to a list of chunk numbers that the IUT needs to send.
8. For each chunk number 'k' in Encoded Missing Chunks field from step 7, the IUT sends a BLOB Chunk Transfer message to the Lower Tester with the Chunk Number field set to 'k' and Chunk Data set to an array of values of length equal to the Chunk Size field from step 7, except for the last chunk, which may be smaller.
9. After 31 s or after the Lower Tester receives all chunks in step 8 (whichever comes first), the Lower Tester sends a BLOB Partial Block Report to the IUT. If the Lower Tester did not receive all the chunks in the current block, the message contains the Encoded Missing Chunks field with a list of chunk numbers that the IUT needs to send.
10. Repeat steps 8–9 until the Lower Tester receives all chunks of block number 'i'.
11. Repeat steps 6–10 for each remaining block number in the closed interval  $[0, \text{ceil}(\text{BLOB Size} / 2^{\text{Block Size Log}})]$ .
12. The Lower Tester checks if the BLOB Data matches the value declared in TSPX\_Client\_BLOB\_Data.

- Expected Outcome

Pass verdict

The IUT transfers the test BLOB from TSPX\_Client\_BLOB\_Data to the Lower Tester.

The IUT signals the Upper Tester that the transfer is complete.

## MBTM/CL/BT/BV-03-C [Cancel Transfer Procedure]

- Test Purpose

Verify that the IUT can cancel a BLOB transfer procedure by sending a BLOB Transfer Cancel message and processing the BLOB Transfer Status.



- Reference

[3] 6.2.8

- Initial Condition

- The test BLOB is defined in the IXIT [5] by TSPX\_Client\_BLOB\_ID and TSPX\_Client\_BLOB\_Data.

- Test Procedure

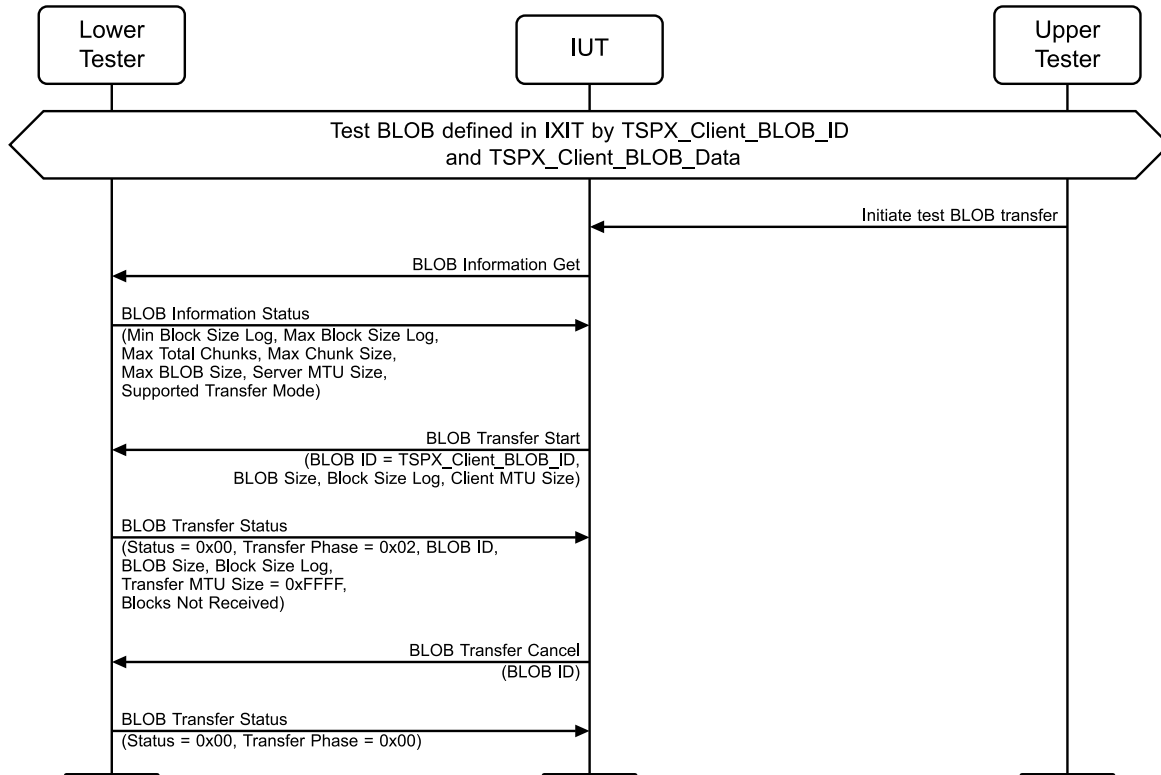

Figure 4.28: MBTM/CL/BT/BV-03-C [Cancel Transfer Procedure]

1. The Upper Tester orders the IUT to initiate the transfer of the test BLOB to the Lower Tester.
2. The IUT sends a BLOB Information Get message.
3. The Lower Tester responds with a BLOB Information Status message with the Min Block Size Log, Max Block Size Log, Max Total Chunks, Max Chunk Size, Max BLOB Size, Server MTU Size, and Supported Transfer Mode fields set to random valid values.
4. The IUT sends a BLOB Transfer Start message with Transfer Mode set to the Supported Transfer Mode value from step 3, BLOB ID and BLOB Size set to the TSPX\_Client\_BLOB\_ID and size of TSPX\_Client\_BLOB\_Data, Block Size Log set to a valid value in the closed interval [Min Block Size Log, Max Block Size Log], and Client MTU Size set to a valid value. All RFU field bits are set to '0'.
5. The Lower Tester responds with a BLOB Transfer Status message with the Status field set to 0x00 (Success), Transfer Mode set to the Supported Transfer Mode value from step 3, Transfer Phase field set to 0x02 (Waiting For Next Block), the BLOB ID, BLOB Size, and Block Size Log fields set to the values from step 4, Transfer MTU Size set to 0xFFFF, and the Blocks Not Received field set to a valid value.
6. The IUT sends a BLOB Transfer Cancel message with the BLOB ID field set to the value from step 5.



7. The Lower Tester responds with a BLOB Transfer Status message with the Status field set to 0x00 (Success), Transfer Mode set to 0x00 (No Active Transfer), and the Transfer Phase field set to 0x00 (Inactive).

- Expected Outcome

Pass verdict

The IUT cancels the BLOB transfer procedure by sending a BLOB Transfer Cancel message with valid values.

### **MBTM/CL/BT/BV-04-C [Transfer BLOB Procedure – Failure]**

- Test Purpose

Verify that the IUT can cancel a BLOB transfer procedure with an active receiver after receiving a BLOB Transfer Status message with an error code.

- Reference

[3] 6.2.3

- Initial Condition

- The test BLOB is defined in the IXIT [5] by TSPX\_Client\_BLOB\_ID and TSPX\_Client\_BLOB\_Data.

- Test Procedure



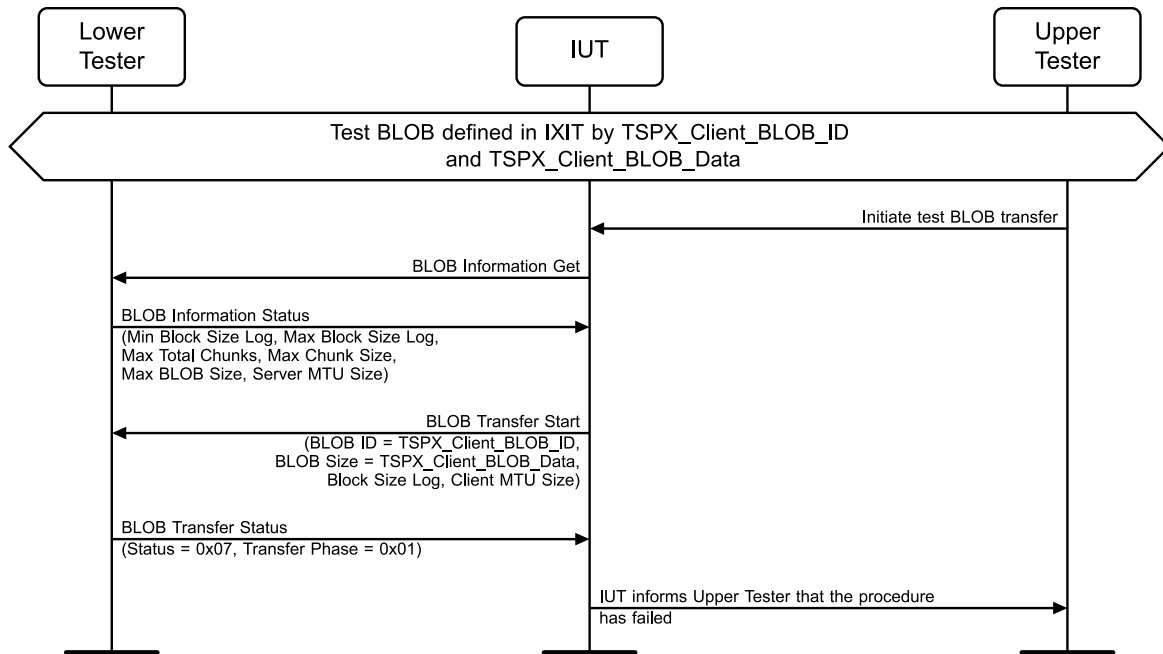

Figure 4.29: MBTM/CL/BT/BV-04-C [Transfer BLOB Procedure - Failure]

1. The Upper Tester orders the IUT to initiate the transfer of the test BLOB to the Lower Tester.
2. The IUT sends a BLOB Information Get message.
3. The Lower Tester responds with a BLOB Information Status message with the Min Block Size Log, Max Block Size Log, Max Total Chunks, Max Chunk Size, Max BLOB Size, Server MTU Size, and Supported Transfer Mode fields set to random valid values.
4. The IUT sends a BLOB Transfer Start message with Transfer Mode set to the Supported Transfer Mode value from step 3, BLOB ID and BLOB Size set to the TSPX\_Client\_BLOB\_ID and size of TSPX\_Client\_BLOB\_Data, Block Size Log set to a valid value in the closed interval [Min Block Size Log, Max Block Size Log], and Client MTU Size set to a valid value. All RFU field bits are set to '0'.
5. The Lower Tester responds with a BLOB Transfer Status message with the Status field set to 0x07 (BLOB Too Large), Transfer Mode set to 0x00 (No Active Transfer), and the Transfer Phase field set to 0x01 (Waiting For Transfer Start).
6. The Lower Tester does not expect any messages from the IUT regarding the test BLOB transfer.
7. The IUT informs the Upper Tester that the procedure failed.

• Expected Outcome

Pass verdict

The IUT cancels the BLOB transfer procedure with the Lower Tester after receiving a BLOB Transfer Status message with an error code.

**MBTM/CL/BT/BV-05-C [Transfer BLOB Procedure – Transfer Timeout]**

• Test Purpose

Verify that the IUT can timeout a Transfer BLOB Procedure with the Lower Tester.



- Reference

[3] 6.2.3

- Initial Condition

- The test BLOB is defined in the IXIT [5] by TSPX\_Client\_BLOB\_ID and TSPX\_Client\_BLOB\_Data.

- Test Procedure

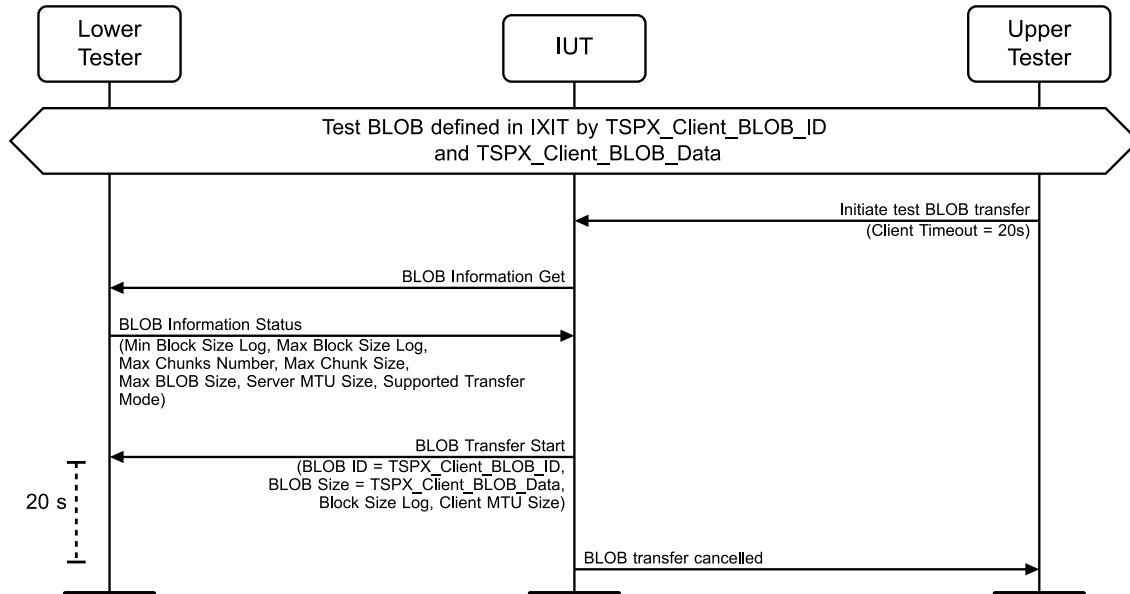

Figure 4.30: MBTM/CL/BT/BV-05-C [Transfer BLOB Procedure – Transfer Timeout]

1. The Upper Tester orders the IUT to initiate the transfer of the test BLOB to the Lower Tester, with Client Timeout Base and Transfer TTL values that result in a Client Timeout value of 20 s.
2. The IUT sends a BLOB Information Get message.
3. The Lower Tester responds with a BLOB Information Status message with the Min Block Size Log, Max Block Size Log, Max Total Chunks, Max Chunk Size, Max BLOB Size, Server MTU Size, and Supported Transfer Mode fields set to random valid values.
4. The IUT sends a BLOB Transfer Start message with Transfer Mode set to the Supported Transfer Mode value from step 3, BLOB ID and BLOB Size set to the TSPX\_Client\_BLOB\_ID and size of TSPX\_Client\_BLOB\_Data, Block Size Log set to a valid value in the closed interval [Min Block Size Log, Max Block Size Log], and Client MTU Size set to a valid value. All RFU field bits are set to '0'.
5. The Lower Tester does not respond.
6. After 20 s, the IUT signals the Upper Tester that the BLOB Transfer procedure has been canceled.

- Expected Outcome

Pass verdict

The IUT cancels the BLOB transfer procedure with the Lower Tester after the procedure timeouts.

### MBTM/CL/BT/BV-06-C [Transfer BLOB Procedure – Partial Block Report Timeout]



- Test Purpose

Verify that the IUT can timeout the Send Data State Machine of a Transfer BLOB Procedure with the Lower Tester.

- Reference

[3] 6.2.3, [3] 6.2.4.2

- Initial Condition

- The test BLOB is defined in the IXIT [5] by TSPX\_Client\_BLOB\_ID and TSPX\_Client\_BLOB\_Data.

- Test Procedure

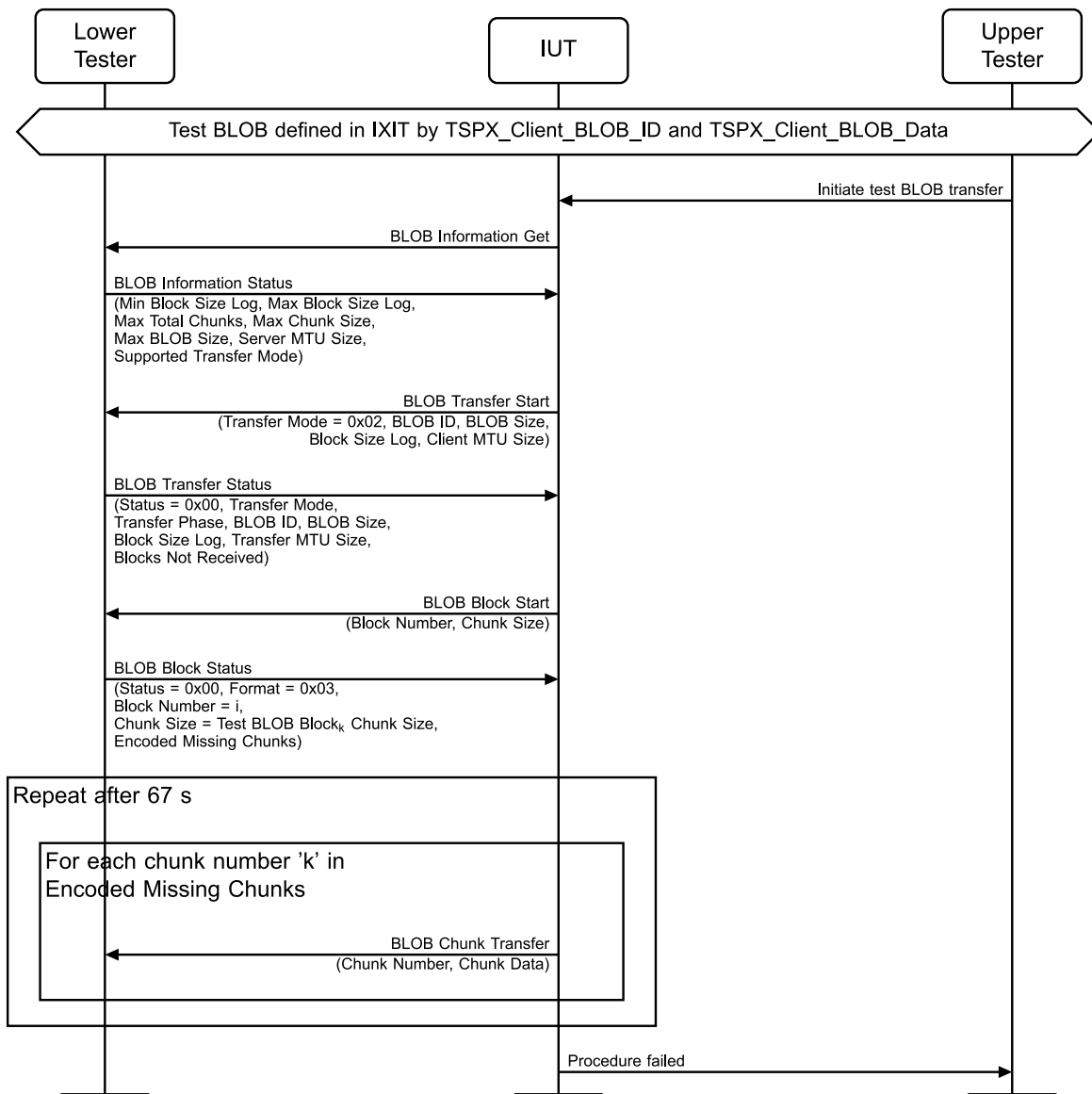

Figure 4.31: MBTM/CL/BT/BV-06-C [Transfer BLOB Procedure – Partial Block Report Timeout]

1. The Upper Tester orders the IUT to initiate the transfer of the test BLOB to the Lower Tester by using a



- valid value for the Transfer TTL.
2. The IUT sends a BLOB Information Get message.
  3. The Lower Tester responds with a BLOB Information Status message with the Min Block Size Log, Max Block Size Log, Max Total Chunks, Max Chunk Size, Max BLOB Size, Server MTU Size, and Supported Transfer Mode field set to 0x02 (Pull).
  4. The IUT sends a BLOB Transfer Start message with Transfer Mode set to 0x02 (Pull), BLOB ID and BLOB Size set to the TSPX\_Client\_BLOB\_ID and size of TSPX\_Client\_BLOB\_Data, Block Size Log set to a valid value in the closed interval [Min Block Size Log, Max Block Size Log], and Client MTU Size set to a valid value. All RFU field bits are set to '0'.
  5. The Lower Tester responds with a BLOB Transfer Status message with the Status field set to 0x00 (Success), Transfer Mode set to 0x02 (Pull), Transfer Phase field set to 0x01 (Waiting For Next Block), the BLOB ID, BLOB Size, and Block Size Log fields set to the values from step 6, Transfer MTU Size set to 0xFFFF, and the Blocks Not Received field set to a valid value.
  6. The IUT sends a BLOB Block Start message to the IUT with Block Number field set to a value in the closed interval  $[0, \text{ceil}(\text{BLOB Size} / 2^{\text{Block Size Log}})]$  and Chunk Size field set to a valid value. The Lower Tester stores the Block Number value as 'i'.
  7. The Lower Tester responds with a BLOB Block Status message with the Status field set to 0x00 (Success), Format field is set to 0x03 (Encoded Missing Chunks), Block Number field set to 'i', the Chunk Size field set to Test BLOB Block<sub>k</sub> Chunk Size, and Encoded Missing Chunks set to a list of chunk numbers that the IUT needs to send.
  8. For each chunk number 'k' in Encoded Missing Chunks field from step 7, the IUT sends a BLOB Chunk Transfer message to the Lower Tester with the Chunk Number field set to 'k' and Chunk Data set to an array of values of length equal to the Chunk Size field from step 7, except for the last chunk, which may be smaller.
  9. After 67 s, which is the initial value for the Block Report timer as defined in [3] 6.2.4.2, the IUT repeats step 8.
  10. Repeat step 9 until the Client Timeout expires (computed using TSPX\_Client\_Timeout\_Base).
  11. The IUT informs the Upper Tester that the procedure failed.

- Expected Outcome

Pass verdict

The IUT sends the messages with the expected valid values and the Transfer TTL set to the value in step 1.

The IUT does not repeat step 8 earlier than 67 s.

## MBTM/CL/BT/BV-07-C [Transfer BLOB Procedure – Disable Receiver]

- Test Purpose

Verify that the IUT acting as a BLOB Transfer Client does not start a new BLOB transfer with a BLOB Transfer Server when the BLOB Transfer Server reports that it cannot support the parameters for transferring a BLOB.

- Reference

[3] 6.2.3



- Initial Condition
  - The test BLOB is defined in the IXIT [5] by TSPX\_Client\_BLOB\_ID and TSPX\_Client\_BLOB\_Data.
- Test Procedure

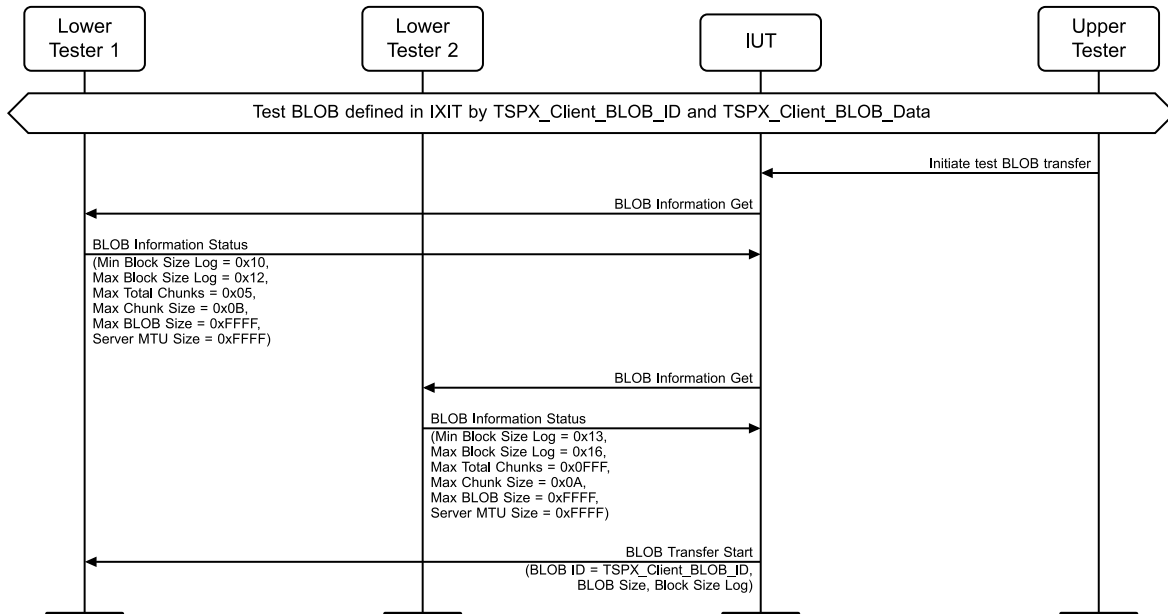

Figure 4.32: MBTM/CL/BT/BV-07-C [Transfer BLOB Procedure – Disable Receiver]

1. The Upper Tester orders the IUT to initiate the transfer of the test BLOB to Lower Tester 1 and Lower Tester 2.
  2. The IUT sends a BLOB Information Get message to Lower Tester 1.
  3. Lower Tester 1 responds with a BLOB Information Status message with the Min Block Size Log set to 0x10, Max Block Size Log set to 0x12, Max Total Chunks set to 0x05, Max Chunk Size set to 0x0B, Max BLOB Size set to 0xFFFF, Server MTU Size set to 0xFFFF, and Supported Transfer Mode set to a random valid value.
  4. The IUT sends a BLOB Information Get message to Lower Tester 2.
  5. Lower Tester 2 responds with a BLOB Information Status message with the Min Block Size Log set to 0x13, Max Block Size Log set to 0x16, Max Total Chunks set to 0x0FFF, Max Chunk Size set to 0x0A, Max BLOB Size set to 0xFFFF, Server MTU Size set to 0xFFFF, and Supported Transfer Mode set the value from step 3.
  6. The IUT sends a BLOB Transfer Start message with Transfer Mode set to the Supported Transfer Mode value from step 3, BLOB ID and BLOB Size set to the TSPX\_Client\_BLOB\_ID and size of TSPX\_Client\_BLOB\_Data, Block Size Log set to a valid value in the closed interval [0x10, 0x16]. All RFU field bits are set to '0'.
  7. If the message in step 6 was sent to a unicast address, then Lower Tester with that address responds with a valid BLOB Transfer Status message, and then the IUT does not send any other BLOB Transfer Start messages.
- Expected Outcome

Pass verdict



The IUT starts the BLOB transfer procedure with one of the Lower Testers, using a block size value supported by the selected Lower Tester, and sending the BLOB Transfer Start message either to the unicast address of the selected Lower Tester or to a group address.

### MBTM/CL/BT/BV-08-C [Get Transfer Progress Procedure]

- Test Purpose

Verify that the IUT can query the state of a BLOB transfer.

- Reference

[3] 6.2.11

- Test Procedure

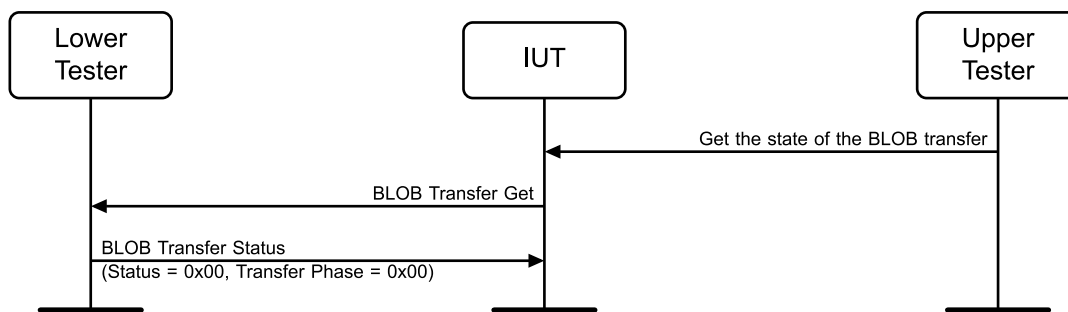

Figure 4.33: MBTM/CL/BT/BV-08-C [Get Transfer Progress Procedure]

1. The Upper Tester orders the IUT to get the state of the BLOB transfer on Lower Tester.
2. The IUT sends a BLOB Transfer Get message.
3. The Lower Tester responds with a BLOB Transfer Status message with the Status field set to 0x00 (Success), Transfer Mode set to 0x00 (No Active Transfer), and Transfer Phase field set to 0x00 (Inactive).

- Expected Outcome

Pass verdict

The IUT sends a BLOB Transfer Get message to the Lower Tester.

## 5 Test case mapping

---

The Test Case Mapping Table (TCMT) maps test cases to specific requirements in the ICS. The IUT is tested in all roles for which support is declared in the ICS document.

The columns for the TCMT are defined as follows:

**Item:** Contains a logical expression based on specific entries from the associated ICS document. Contains a logical expression (using the operators AND, OR, NOT as needed) based on specific entries from the applicable ICS document(s). The entries are in the form of y/x references, where y corresponds to the table number and x corresponds to the feature number as defined in the ICS document for the Mesh Binary Large Object Transfer Model Specification [4].

**Feature:** A brief, informal description of the feature being tested.

**Test Case(s):** The applicable test case identifiers are required for Bluetooth Qualification if the corresponding y/x references defined in the Item column are supported. Further details about the function of the TCMT are elaborated in [2].

For the purpose and structure of the ICS/IXIT, refer to [2].

Item	Feature	Test Case(s)
MBTM 3/1	BLOB Transfer Server	MBTM/SR/BT/BV-03-C MBTM/SR/BT/BV-06-C MBTM/SR/BT/BV-09-C MBTM/SR/BT/BV-11-C MBTM/SR/BT/BV-12-C MBTM/SR/BT/BV-15-C MBTM/SR/BT/BV-16-C MBTM/SR/BT/BV-17-C MBTM/SR/BT/BV-18-C MBTM/SR/BT/BV-21-C MBTM/SR/BT/BV-22-C MBTM/SR/BT/BV-23-C MBTM/SR/BT/BV-24-C MBTM/SR/BT/BV-27-C MBTM/SR/BT/BV-28-C MBTM/SR/BT/BV-29-C MBTM/SR/BT/BV-30-C MBTM/SR/BT/BV-31-C MBTM/SR/BT/BV-32-C MBTM/SR/BT/BV-33-C MBTM/SR/BT/BV-34-C MBTM/SR/BT/BV-35-C MBTM/SR/BT/BV-36-C MBTM/SR/BT/BV-37-C MBTM/SR/BT/BV-38-C MBTM/SR/BT/BI-01-C MBTM/SR/BT/BI-02-C
MBTM 10/1	Pull BLOB Transfer mode	MBTM/SR/BT/BV-02-C MBTM/SR/BT/BV-05-C MBTM/SR/BT/BV-07-C MBTM/SR/BT/BV-08-C MBTM/SR/BT/BV-10-C MBTM/SR/BT/BV-14-C MBTM/SR/BT/BV-20-C MBTM/SR/BT/BV-26-C
MBTM 10/2	Push BLOB Transfer mode	MBTM/SR/BT/BV-01-C MBTM/SR/BT/BV-04-C MBTM/SR/BT/BV-13-C MBTM/SR/BT/BV-19-C MBTM/SR/BT/BV-25-C

Item	Feature	Test Case(s)
MBTM 3/2	BLOB Transfer Client	MBTM/CL/BT/BV-01-C MBTM/CL/BT/BV-02-C MBTM/CL/BT/BV-03-C MBTM/CL/BT/BV-04-C MBTM/CL/BT/BV-05-C MBTM/CL/BT/BV-06-C MBTM/CL/BT/BV-07-C MBTM/CL/BT/BV-08-C

Table 5.8: Test case mapping

## 6 Revision history and acknowledgments

### Revision History

Publication Number	Revision Number	Date	Comments
0	p0	2023-09-19	Approved by BTI on 2023-08-27. Mesh Model v1.1 adopted by the BoD on 2023-09-12. Prepared for publication.
	p1r00-r01	2024-02-06 – 2024-03-27	TSE 24048 (rating 3): Updated the preamble procedure for IUT in Suspended Phase, Block Number Unset and Block Number Set. Updated the test procedure for MBT/CL/BT/BV-06-C and MBT/SR/BT/BV-05-C and -06-C. TSE 25134 (rating 1): Updated all instances of “MBT” to “MBTM” to reflect that the Mesh Device Firmware Update spec is a model spec.
1	p1	2024-07-01	Approved by BTI on 2024-04-18. Prepared for TCRL 2024-1 publication.
	p2r00-r02	2025-02-20 – 2025-04-28	TSE 26975 (rating 2): Updated the TCMT for test cases MBTM/SR/BT/BV-02-C, -05-C, -07-C, -08-C, -10-C, -14-C, -20-C, and -26-C.
2	p2	2025-07-08	Approved by BTI on 2025-05-28. Prepared for TCRL pkg100 publication.
	p3r00-r01	2026-05-06	TSE 27976 (rating 1): Updated initial condition in MBTM/SR/BT/BV-05-C, MBTM/SR/BT/BV-07-C, MBTM/SR/BT/BV-08-C, MBTM/SR/BT/BV-10-C. TSE 28800 (rating 2): Updated the Test Strategy.
3	p3	2026-06-23	Approved by BTI on 2026-06-02. Prepared for TCRL pkg104 publication.

### Acknowledgments

Name	Company
Bogdan Alexandru	Bluetooth SIG, Inc.
Alex Andreescu	Bluetooth SIG, Inc.
Jim Harper	Bluetooth SIG, Inc.
Tibi Marinescu	Bluetooth SIG, Inc.

