

# Location and Navigation Profile (LNP)

## **Bluetooth® Test Suite**

---

- **Revision:** LNP.TS.p9
- **Revision Date:** 2025-11-04
- **Prepared By:** BTI
- **Published during TCRL:** TCRL.pkg101



This document, regardless of its title or content, is not a Bluetooth Specification as defined in the Bluetooth Patent/Copyright License Agreement (“PCLA”) and Bluetooth Trademark License Agreement. Use of this document by members of Bluetooth SIG is governed by the membership and other related agreements between Bluetooth SIG Inc. (“Bluetooth SIG”) and its members, including the PCLA and other agreements posted on Bluetooth SIG’s website located at [www.bluetooth.com](http://www.bluetooth.com).

THIS DOCUMENT IS PROVIDED “AS IS” AND BLUETOOTH SIG, ITS MEMBERS, AND THEIR AFFILIATES MAKE NO REPRESENTATIONS OR WARRANTIES AND DISCLAIM ALL WARRANTIES, EXPRESS OR IMPLIED, INCLUDING ANY WARRANTY OF MERCHANTABILITY, TITLE, NON-INFRINGEMENT, FITNESS FOR ANY PARTICULAR PURPOSE, THAT THE CONTENT OF THIS DOCUMENT IS FREE OF ERRORS.

TO THE EXTENT NOT PROHIBITED BY LAW, BLUETOOTH SIG, ITS MEMBERS, AND THEIR AFFILIATES DISCLAIM ALL LIABILITY ARISING OUT OF OR RELATING TO USE OF THIS DOCUMENT AND ANY INFORMATION CONTAINED IN THIS DOCUMENT, INCLUDING LOST REVENUE, PROFITS, DATA OR PROGRAMS, OR BUSINESS INTERRUPTION, OR FOR SPECIAL, INDIRECT, CONSEQUENTIAL, INCIDENTAL OR PUNITIVE DAMAGES, HOWEVER CAUSED AND REGARDLESS OF THE THEORY OF LIABILITY, AND EVEN IF BLUETOOTH SIG, ITS MEMBERS, OR THEIR AFFILIATES HAVE BEEN ADVISED OF THE POSSIBILITY OF SUCH DAMAGES.

This document is proprietary to Bluetooth SIG. This document may contain or cover subject matter that is intellectual property of Bluetooth SIG and its members. The furnishing of this document does not grant any license to any intellectual property of Bluetooth SIG or its members.

This document is subject to change without notice.

Copyright © 2013-2025 by Bluetooth SIG, Inc. The Bluetooth word mark and logos are owned by Bluetooth SIG, Inc. Other third-party brands and names are the property of their respective owners.



# Contents

<b>1</b>	<b>Scope</b> .....	<b>5</b>
<b>2</b>	<b>References, definitions, and abbreviations</b> .....	<b>6</b>
2.1	References .....	6
2.2	Definitions .....	6
2.3	Acronyms and abbreviations .....	6
<b>3</b>	<b>Test Suite Structure (TSS)</b> .....	<b>7</b>
3.1	Overview .....	7
3.2	Test Strategy .....	7
3.2.1	Test database requirements .....	8
3.3	Test groups .....	8
<b>4</b>	<b>Test cases (TC)</b> .....	<b>9</b>
4.1	Introduction .....	9
4.1.1	Test case identification conventions .....	9
4.1.2	Conformance .....	9
4.1.3	Pass/Fail verdict conventions .....	10
4.2	Setup preambles .....	10
4.2.1	ATT Bearer on LE Transport .....	10
4.2.2	ATT Bearer on BR/EDR Transport .....	10
4.2.3	Collector: Configure LN Sensor for use with LN Control Point .....	11
4.2.4	LE Collector: Scan to detect Sensor Connectable Advertisements and initiate a connection .....	11
4.2.5	BR/EDR Collector .....	12
4.3	Generic GATT Integrated Tests .....	14
	LNP/COL/CGGIT/SER/BV-01-C [Service GGIT – Location and Navigation Service] .....	14
	LNP/COL/CGGIT/SER/BV-02-C [Service GGIT – Device Information Service] .....	14
	LNP/COL/CGGIT/SER/BV-03-C [Service GGIT – Battery Service] .....	14
	LNP/COL/CGGIT/CHA/BV-01-C [Characteristic GGIT – LN Feature] .....	14
	LNP/COL/CGGIT/CHA/BV-02-C [Characteristic GGIT – Location and Speed] .....	14
	LNP/COL/CGGIT/CHA/BV-03-C [Characteristic GGIT – Position Quality] .....	14
	LNP/COL/CGGIT/CHA/BV-04-C [Characteristic GGIT – Navigation] .....	14
	LNP/COL/CGGIT/CHA/BV-05-C [Characteristic GGIT – LN Control Point] .....	14
	LNP/COL/CGGIT/CHA/BV-06-C [Characteristic GGIT – Battery Level] .....	14
	LNP/SEN/SGGIT/SDPNF/BV-01-C [Not discoverable over BR/EDR – Location and Navigation Service] .....	14
4.3.1	Generic GATT Indication Supported Features characteristic .....	15
	LNP/COL/CGGIT/ISFC/BV-01-C [Characteristic GGIT – LN Feature indication] .....	15
4.4	Discover Services and Characteristics .....	16
	LNP/COL/LND/BV-14-C [Discover Device Information Service Characteristics] .....	16
	LNP/COL/LND/BV-15-C [Read Device Information Service Characteristics] .....	17
4.5	LN Feature .....	18
	LNP/SEN/LNF/BV-01-C [Location and Navigation Service UUID in AD] .....	18
	LNP/SEN/LNF/BV-02-C [Local Name included in AD or Scan Response] .....	18
	LNP/SEN/LNF/BV-03-C [Appearance included in AD or Scan Response] .....	19
	LNP/COL/LNF/BI-01-C [LN Feature characteristic with reserved value] .....	20
	LNP/COL/LNF/BV-05-C [Configure Location and Speed for Notification] .....	21
	LNP/COL/LNF/BV-06-C [Receive Location and Speed Notifications] .....	22
	LNP/COL/LNF/BV-07-C [Receive Location and Speed Notifications – Total Distance Roll Over] .....	24
	LNP/COL/LNF/BV-08-C [Receive Speed and Location Notifications – Rolling Time Roll Over] .....	25
	LNP/COL/LNF/BI-02-C [Receive Location and Speed Notifications with reserved flags] .....	26



LNP/COL/LNF/BI-03-C [Receive Location and Speed Notifications with additional octets not represented in the flags field] .....	27
LNP/COL/LNF/BV-09-C [Read Position Quality characteristic] .....	28
LNP/COL/LNF/BI-04-C [Read Position Quality characteristic with reserved value] .....	30
LNP/COL/LNF/BV-10-C [Configure Navigation for Notification] .....	30
LNP/COL/LNF/BV-11-C [Receive Navigation Notifications] .....	31
LNP/COL/LNF/BI-05-C [Receive Navigation Notifications with reserved flags] .....	33
LNP/COL/LNF/BV-12-C [Lost Bond Procedure when using LE Transport] .....	34
LNP/COL/LNF/BV-13-C [Lost Bond Procedure when using BR/EDR transport] .....	35
LNP/COL/LNF/BV-14-C [Read LN Feature Characteristic with Bonding Enabled] .....	36
LNP/COL/LNF/BV-15-C [Enable LN Feature Characteristic for Indication or Read Feature Characteristic Upon Reconnection] .....	36
<b>4.6 Service Procedures – Set Cumulative Value</b> .....	<b>37</b>
LNP/COL/SPS/BV-01-C [Set Cumulative Value – Set to zero] .....	37
LNP/COL/SPS/BV-02-C [Set Cumulative Value – Set to non-zero] .....	38
<b>4.7 Service Procedure – Mask Characteristic Content</b> .....	<b>39</b>
LNP/COL/SPM/BV-01-C [Mask Location and Speed Characteristic Content] .....	39
<b>4.8 Service Procedures – Navigation Control</b> .....	<b>39</b>
LNP/COL/SPN/BV-01-C [Request Number of Routes] .....	39
LNP/COL/SPN/BV-02-C [Request Name of Route] .....	40
LNP/COL/SPN/BV-03-C [Select Route] .....	40
LNP/COL/SPN/BV-04-C [Navigation Control – Start] .....	41
LNP/COL/SPN/BV-05-C [Navigation Control – Stop] .....	42
LNP/COL/SPN/BV-06-C [Navigation Control – Pause and Continue] .....	42
LNP/COL/SPN/BV-07-C [Navigation Control – Skip Waypoint] .....	43
LNP/COL/SPN/BV-08-C [Navigation Control – Select Nearest Waypoint on a Route] .....	44
<b>4.8.1 Service Procedure – Set Fix Rate</b> .....	<b>45</b>
LNP/COL/SPF/BV-01-C [Set Fix Rate] .....	45
<b>4.9 Service Procedure – Set Elevation</b> .....	<b>46</b>
LNP/COL/SPA/BV-01-C [Set Elevation] .....	46
<b>4.10 Service Procedures – General Error Handling</b> .....	<b>46</b>
LNP/COL/SPE/BI-01-C [Unsupported Op Code] .....	46
LNP/COL/SPE/BI-02-C [Invalid Parameter] .....	47
LNP/COL/SPE/BI-03-C [Operation Failed] .....	48
LNP/COL/SPE/BI-04-C [LN Control Point Procedure Timeout] .....	48
<b>5 Test case mapping</b> .....	<b>50</b>
<b>6 Revision history and acknowledgments</b> .....	<b>52</b>

# 1 Scope

---

This Bluetooth document contains the Test Suite Structure (TSS) and test cases to test the implementation of the Bluetooth Location and Navigation Profile Specification with the objective to provide a high probability of air interface interoperability between the tested implementation and other manufacturers' Bluetooth devices.

## 2 References, definitions, and abbreviations

---

### 2.1 References

This document incorporates provisions from other publications by dated or undated reference. These references are cited at the appropriate places in the text, and the publications are listed hereinafter. Additional definitions and abbreviations can be found in [1] and [2].

- [1] Test Strategy and Terminology Overview
- [2] Bluetooth Core Specification, Version 4.0 or later
- [3] Location and Navigation Profile Specification, Version 1.0 or later
- [4] Location and Navigation Profile ICS, LNP.ICS
- [5] GATT Test Suite, GATT.TS
- [6] Location and Navigation Service Specification, Version 1.0 or later
- [7] Location and Navigation Service Test Suite, LNS.TS
- [8] Device Information Service Specification, Version 1.1
- [9] Battery Service Specification, Version 1.0
- [10] IXIT Proforma for Location and Navigation Profile
- [11] Characteristic and Descriptor descriptions are accessible via the [Bluetooth SIG Assigned Numbers](#)
- [12] Location and Navigation Profile Specification, Version 1.0.1

### 2.2 Definitions

In this Bluetooth document, the definitions from [1] and [2] apply.

### 2.3 Acronyms and abbreviations

In this Bluetooth document, the definitions, acronyms, and abbreviations from [1] and [2] apply.

### 3 Test Suite Structure (TSS)

#### 3.1 Overview

The Location and Navigation Profile requires the presence of GAP, SM, and GATT. This is illustrated in Figure 3.1.

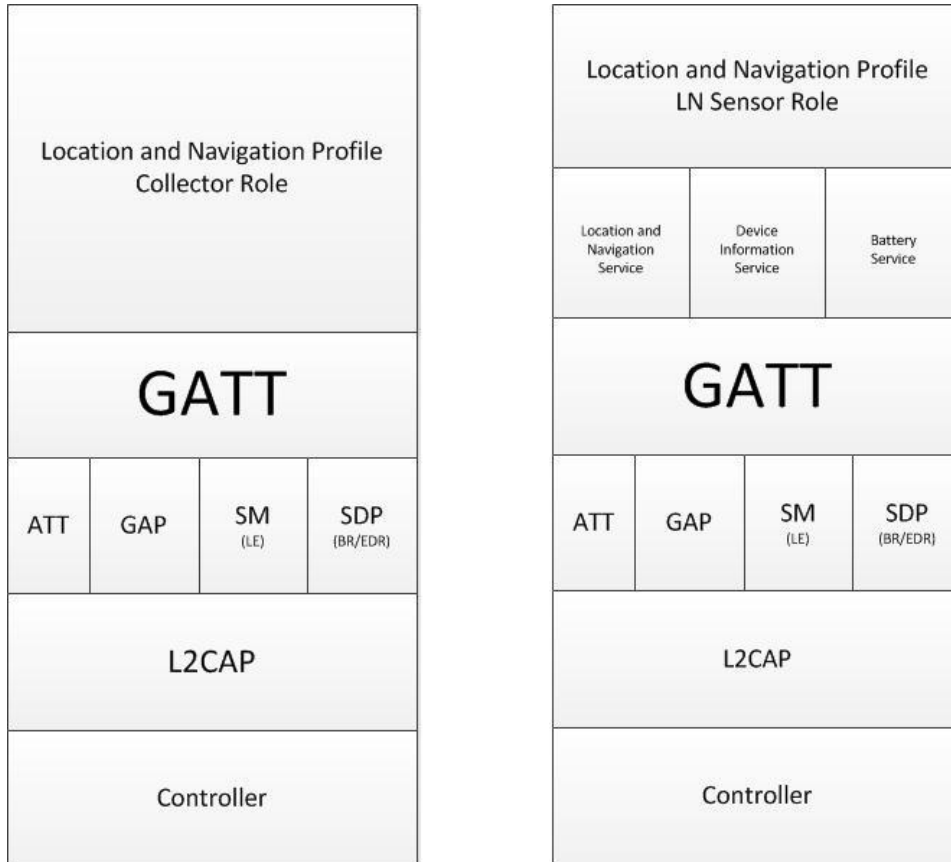

Figure 3.1: Location and Navigation test model

#### 3.2 Test Strategy

The test objectives are to verify functionality of the Location and Navigation Profile within a Bluetooth Host and enable interoperability between Bluetooth Hosts on different devices. The testing approach covers mandatory and optional requirements in the specification and matches these to the support of the IUT as described in the ICS. Any defined test herein is applicable to the IUT if the ICS logical expression defined in the Test Case Mapping Table (TCMT) evaluates to true.

The test equipment provides an implementation of the Radio Controller and the parts of the Host needed to perform the test cases defined in this Test Suite. A Lower Tester acts as the IUT’s peer device and interacts with the IUT over-the-air interface. The configuration, including the IUT, needs to implement similar capabilities to communicate with the test equipment. For some test cases, it is necessary to stimulate the IUT from an Upper Tester. In practice, this could be implemented as a special test interface, a Man Machine Interface (MMI), or another interface supported by the IUT.

This Test Suite contains Valid Behavior (BV) tests complemented with Invalid Behavior (BI) tests where required. The test coverage mirrored in the Test Suite Structure is the result of a process that started with catalogued specification requirements that were logically grouped and assessed for testability enabling coverage in defined test purposes.

### 3.2.1 Test database requirements

The following requirements apply to the set of databases used by the Lower Tester for testing of GATT Client functionality:

- The Lower Tester includes one instantiation of each of the services used by this profile including all defined characteristics.
- Each service instantiation also contains two «future» characteristics.
  - If possible, with one inserted before the first characteristic defined
  - If possible, with one appended after the last characteristic defined
- Each «future» characteristic has a 16-bit UUID randomly selected from unassigned UUIDs at the time of the test.

### 3.3 Test groups

The following test groups have been defined:

- Generic GATT Integrated Tests
- Discovery of Services and Characteristics
- Features
- Service Procedures

## 4 Test cases (TC)

### 4.1 Introduction

#### 4.1.1 Test case identification conventions

Test cases are assigned unique identifiers per the conventions in [1]. The convention used here is: **<spec abbreviation>/<IUT role>/<class>/<feat>/<func>/<subfunc>/<cap>/<xx>-<nn>-<y>**.

Additionally, testing of this specification includes tests from the GATT Test Suite [5] referred to as Generic GATT Integrated Tests (GGIT); when used, the test cases in GGIT are referred to through a TCID string using the following convention:

**<spec abbreviation>/<IUT role>/<GGIT test group>/< GGIT class >/<xx>-<nn>-<y>**.

Identifier Abbreviation	Spec Identifier <spec abbreviation>
LNP	Location and Navigation Profile
Identifier Abbreviation	Role Identifier <IUT role>
COL	Collector Role
SEN	LN Sensor Role
Identifier Abbreviation	Reference Identifier <GGIT test group>
CGGIT	Client Generic GATT Integrated Tests
SGGIT	Server Generic GATT Integrated Tests
Identifier Abbreviation	Reference Identifier <GGIT class>
CHA	Characteristic
ISFC	Indication Supported Features Characteristic
SDPNF	SDP Record Not Found
SER	Service
Identifier Abbreviation	Feature Identifier <feat>
LND	Discovery of Services and Characteristics
LNF	Features
SPA	Service Procedure – Set Elevation (Altitude)
SPE	Service Procedure – Error Handling
SPF	Service Procedure – Set Fix Rate
SPM	Service Procedure – Mask Location and Speed Characteristic Content
SPN	Service Procedures – Navigation
SPS	Service Procedure – Set Cumulative Value

Table 4.1: LNP TC feature naming conventions

#### 4.1.2 Conformance

When conformance is claimed for a particular specification, all capabilities are to be supported in the specified manner. The mandated tests from this Test Suite depend on the capabilities to which conformance is claimed.

The Bluetooth Qualification Program may employ tests to verify implementation robustness. The level of implementation robustness that is verified varies from one specification to another and may be revised for cause based on interoperability issues found in the market.



Such tests may verify:

- That claimed capabilities may be used in any order and any number of repetitions not excluded by the specification
- That capabilities enabled by the implementations are sustained over durations expected by the use case
- That the implementation gracefully handles any quantity of data expected by the use case
- That in cases where more than one valid interpretation of the specification exists, the implementation complies with at least one interpretation and gracefully handles other interpretations
- That the implementation is immune to attempted security exploits

A single execution of each of the required tests is required to constitute a Pass verdict. However, it is noted that to provide a foundation for interoperability, it is necessary that a qualified implementation consistently and repeatedly pass any of the applicable tests.

In any case, where a member finds an issue with the test plan generated by the Bluetooth SIG qualification tool, with the test case as described in the Test Suite, or with the test system utilized, the member is required to notify the responsible party via an erratum request such that the issue may be addressed.

### 4.1.3 Pass/Fail verdict conventions

Each test case has an Expected Outcome section. The IUT is granted the Pass verdict when all the detailed pass criteria conditions within the Expected Outcome section are met.

The convention in this Test Suite is that, unless there is a specific set of fail conditions outlined in the test case, the IUT fails the test case as soon as one of the pass criteria conditions cannot be met. If this occurs, the outcome of the test is a Fail verdict.

## 4.2 Setup preambles

The procedures defined in this section are provided for information, as they are used by test equipment in achieving the initial conditions in certain tests.

### 4.2.1 ATT Bearer on LE Transport

- Preamble Procedure
  1. Establish an LE transport connection between the IUT and the Lower Tester.
  2. Establish an L2CAP channel 0x0004 between the IUT and the Lower Tester over that LE transport.

### 4.2.2 ATT Bearer on BR/EDR Transport

- Preamble Procedure
  1. Establish a BR/EDR transport connection between the IUT and the Lower Tester.
  2. Establish several L2CAP channels (PSM 0x001F) between the IUT and the Lower Tester over that BR/EDR transport.

### 4.2.3 Collector: Configure LN Sensor for use with LN Control Point

- Preamble Purpose

This preamble procedure specifies how the Collector IUT configures the LN Sensor for use with LN Control Point and is valid for LE and BR/EDR transports.

- Preamble Procedure

1. Establish an ATT Bearer connection between the Lower Tester and IUT as described in Section 4.2.1, if using an LE transport, or Section 4.2.2 if using a BR/EDR transport.
2. The handles of the LN Feature, the Location and Speed, the Position Quality, the LN Control Point and the Navigation characteristics have been previously discovered by the Lower Tester during the test procedures starting in Section 4.3 or are known to the Lower Tester by other means.
3. The handles of the Client Characteristic Configuration descriptor of the Location and Speed characteristic, Navigation characteristic and the LN Control Point characteristic have been previously discovered by the Lower Tester during the test procedures starting in Section 4.3 or are known to the Lower Tester by other means.
4. The Lower Tester may perform a bonding procedure. If previously bonded, enable encryption if not already enabled.
5. The Location and Speed characteristic is configured for notifications.
6. The LN Control Point characteristic is configured for indications.
7. The Navigation characteristic, if discovered, is configured for notifications.

### 4.2.4 LE Collector: Scan to detect Sensor Connectable Advertisements and initiate a connection

- Preamble Purpose

This LE preamble procedure specifies how the Collector IUT scans for LN Sensor connectable advertisements for the case when a Sensor has new data available.

- Reference

[3] 5.2

[2] 9.3.3 and 9.3.4

- Preamble Procedure

1. Configure the Collector IUT to accept commands from the Upper Tester to receive data from the LN Sensor (Lower Tester).
2. The Upper Tester commands the Collector IUT to initiate a connection and the IUT starts scanning.
3. The LN Sensor (Lower Tester) advertises to the Collector IUT either using:
  - ALT 1: GAP Directed Connectable Mode (send ADV\_DIRECT\_IND packets)
  - or
  - ALT 2: GAP Undirected Connectable Mode (send ADV\_IND packets)
4. The Lower Tester waits for responses from the Collector IUT.
5. The Collector IUT sends a CONNECT\_REQ and an optionally empty PDU to the Lower Tester.

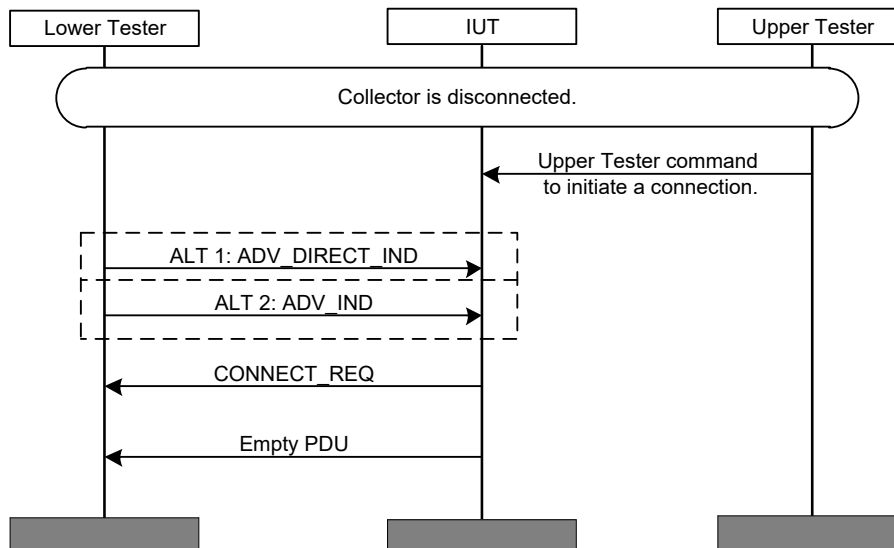

Figure 4.1: Preamble for LE Collector: Scan to detect Sensor Connectable Advertisements and initiate a connection

## 4.2.5 BR/EDR Collector

### 4.2.5.1 Unbonded Devices

- Preamble Purpose

This BR/EDR preamble procedure specifies how the Collector IUT scans for the LN Sensor for the case when an LN Sensor has new records available.

- Reference

[3] 5.3

[2] 4.1 and 4.2

- Preamble Procedure

1. Configure the Collector IUT to accept commands to receive data from the LN Sensor (Lower Tester).
2. Put the LN Sensor in General Discoverable mode.
3. The Upper Tester commands the Collector IUT to initiate a connection and the IUT starts scanning.
4. The LN Sensor (Lower Tester) exposes the SDP record for the Location and Navigation Service.
5. The Collector IUT validates the SDP record and establishes a connection to the LN Sensor.
6. The Collector uses the GAP General Discovery procedure to discover an LN Sensor to establish a connection to an LN Sensor.

### 4.2.5.2 Bonded Devices

- Preamble Purpose

In case of BR/EDR, either an LN Sensor or Collector could initiate connection when they are bonded. The device initiating the connection becomes a Central and is referred to here as the “paging device”

and the device accepting the connection becomes a Peripheral and is referred to here as the “page scanning device”.

This BR/EDR preamble procedure specifies how a paging device connects to a page scanning device.

- Reference

[3] 5.3

[2] 4.1 and 4.2

- Preamble Procedure

1. Configure the Collector IUT to accept commands to receive data from the LN Sensor (Lower Tester).
2. Put the page scanning device in connectable mode to accept a connection from the paging device.
3. The connection is initiated by the paging device.
4. The Peripheral exposes the SDP record for the Location and Navigation Service.
5. The Central validates the SDP record and establishes a connection to the Peripheral.
6. The Central uses the GAP Link Establishment Procedure to connect to any bonded device.

### 4.3 Generic GATT Integrated Tests

Execute the Generic GATT Integrated Tests defined in [5] in Section 6.3, Server test procedures (SGGIT), and in Section 6.4, Client test procedures using Table 4.2 as input:

TCID	Service / Characteristic / Descriptor	Reference	Properties	Value Length (Octets)	Service Type
LNP/COL/CGGIT/SER/BV-01-C [Service GGIT – Location and Navigation Service]	Location and Navigation Service	[3] 3	-	-	Primary Service
LNP/COL/CGGIT/SER/BV-02-C [Service GGIT – Device Information Service]	Device Information Service	[3] 3	-	-	Primary Service
LNP/COL/CGGIT/SER/BV-03-C [Service GGIT – Battery Service]	Battery Service	[3] 3	-	-	Primary Service
LNP/COL/CGGIT/CHA/BV-01-C [Characteristic GGIT – LN Feature]	LN Feature Characteristic	[3] 4.3.1	0x22 (Read, Indicate)	4	-
LNP/COL/CGGIT/CHA/BV-02-C [Characteristic GGIT – Location and Speed]	Location and Speed Characteristic	[3] 4.3.1	0x10 (Notify)	Skip	-
LNP/COL/CGGIT/CHA/BV-03-C [Characteristic GGIT – Position Quality]	Position Quality Characteristic	[3] 4.3.1	0x02 (Read)	Skip	-
LNP/COL/CGGIT/CHA/BV-04-C [Characteristic GGIT – Navigation]	Navigation Characteristic	[3] 4.3.1	0x10 (Notify)	Skip	-
LNP/COL/CGGIT/CHA/BV-05-C [Characteristic GGIT – LN Control Point]	LN Control Point Characteristic	[3] 4.3.1	0x28 (Write, Indicate)	Skip	-
LNP/COL/CGGIT/CHA/BV-06-C [Characteristic GGIT – Battery Level]	Battery Level Characteristic	[3] 4.3.3	0x12 (Read, Notify)	1	-
LNP/SEN/SGGIT/SDPNF/BV-01-C [Not discoverable over BR/EDR – Location and Navigation Service]	Location and Navigation Service	[3] 2.5	-	-	-

Table 4.2: Input for the GGIT Server test procedure



### 4.3.1 Generic GATT Indication Supported Features characteristic

Execute the Generic GATT Indication Supported Features Characteristic Tests defined in Section 6.4 [5] Client Test Procedures using Table 4.3 Input for the GGIT Indication Supported Features Characteristic Tests below as input:

TCID	Characteristic	Reference	TC Configuration
LNP/COL/CGGIT/ISFC/BV-01-C [Characteristic GGIT – LN Feature indication]	LN Feature	[12] 4.4	N/A

Table 4.3 Input for the GGIT Indication Supported Features Characteristic Tests



## 4.4 Discover Services and Characteristics

The procedures defined in this test group verify the IUT's ability to discover the services and characteristics exposed by an LN Sensor (Lower Tester).

### LNP/COL/LND/BV-14-C [Discover Device Information Service Characteristics]

- Test Purpose
 

Verify that a Collector IUT can discover all characteristics of a Device Information Service supported by the IUT.
- Reference
 

[3] 4.3.2
- Initial Condition
  - Via IXIT [10] the IUT manufacturer specifies all characteristics of the Device Information Service supported by the IUT.
  - Run the preamble procedure to enable the Collector to initiate connection to an LN Sensor included in Section 4.2.4, if using an LE transport, or Section 4.2.5 if using a BR/EDR transport.
  - The IUT has executed the LNP/COL/CGGIT/SER/BV-02-C [Service GGIT – Device Information Service] procedure and has saved the handle range for the instantiation of the Device Information Service contained in the Lower Tester. The Device Information Service contains one or more characteristics.
- Test Procedure
  1. The Upper Tester issues a command to the IUT to discover all characteristics of the Device Information Service supported by the IUT.
  2. The IUT executes either alternative 2A or 2B.
 

Alternative 2A (Discover All Characteristics of a Service sub-procedure):

2A: Discover All Characteristics of a Service using the specified handle range, with the Lower Tester instantiating the database specified in Section 3.2.1.

Alternative 2B (Discover Characteristics by UUID sub-procedure):

2B: Discover Characteristics by UUID using each of the UUIDs for the characteristics of the Device Information Service supported by the IUT, with the Lower Tester instantiating the database specified in in Section 3.2.1.
- Expected Outcome
 

Pass verdict

For each characteristic supported by the IUT contained in the Lower Tester's instantiation of the Device Information Service, the IUT reports an attribute handle/value pair for each characteristic specified in the IXIT [10] to the Upper Tester.

## LNP/COL/LND/BV-15-C [Read Device Information Service Characteristics]

- Test Purpose

Verify that a Collector IUT can read all characteristics of a Device Information Service supported by the IUT.

- Reference

[3] 3.2 and 4.9

- Initial Condition

- Via IXIT [10] the IUT manufacturer specifies all characteristics of the Device Information Service supported by the IUT.
- Run the preamble procedure for the Collector to initiate connection to an LN Sensor included in Section 4.2.4, if using an LE transport, or Section 4.2.5 if using a BR/EDR transport.
- The Lower Tester includes one instantiation of the Device Information Service [8] including all defined characteristics.
- The IUT has previously executed the procedure included in LNP/COL/LND/BV-14-C [Discover Device Information Service Characteristics], so it has the handle/value pairs for all characteristics of the Device Information Service supported by the IUT.

- Test Procedure

1. For string based characteristics (i.e., Manufacturer Name String, Model Number String, Serial Number String, Hardware Revision String, Firmware Revision String and Software Revision String), this test is run twice, and a disconnection may occur between the two tests. In the first pass, the string includes only character values in the ASCII printable range (i.e., 0x20 – 0x7E). In the second pass, the string includes character values outside the ASCII printable range. For System ID characteristic, the Manufacturer Identifier is set to 0xFFFE9ABCDE and Organizationally Unique Identifier is set to 0x123456. For 11073-20601 Regulatory Certification Data List characteristic, the Data field is set to 0x0000-0002-8008-0200-0001-0105-0008-0201-0012-0002. For PnP\_ID characteristic, the Vendor ID Source is set to 0x01, the Vendor ID is set to 0x006B, the Product ID is set to 0x1234 and the Product Version is set to 0x0102.
2. The Upper Tester issues a command to the IUT to read all characteristics of the Device Information Service supported by the IUT.
3. For each characteristic of the Device Information Service supported by the IUT, the IUT sends an ATT\_Read\_Request to the Lower Tester containing the handle specified by the Upper Tester.
4. The IUT receives an ATT\_Read\_Response and reports the value to the Upper Tester.

- Expected Outcome

### Pass verdict

For each characteristic contained in the Lower Tester's instantiation of the Device Information Service supported by the IUT, the IUT reports the characteristic value for all characteristics specified in the IXIT [10] to the Upper Tester, including:

- For string-based characteristics, any printable or non-printable ASCII values
- For System ID characteristic, the Manufacturer Identifier and Organizationally Unique Identifier

- For 11073-20601 Regulatory Certification Data List characteristic, the IEEE 11073-20601 regulatory certification data list (note that this value is defined in big endian format)
- For PnP\_ID characteristic, the Vendor ID Source, the Vendor ID, the Product ID and the Product Version

## 4.5 LN Feature

The procedures defined in this test group verify LN Sensor IUT implementation of the features defined in the Location and Navigation Profile Specification [3] by an LN Sensor IUT, and usage of the same features by a Collector IUT.

### LNP/SEN/LNF/BV-01-C [Location and Navigation Service UUID in AD]

- Test Purpose
 

Verify that the Location and Navigation Service UUID is included in AD (Advertising Data) from the LN Sensor IUT when using the LE Transport.
- Reference
 

[3] 3.1.1.1
- Initial Condition
  - The IUT is powered on in GAP Discoverable Mode.
  - The IUT is induced to generate Advertising Packets using preamble defined in Section 4.2.4.
- Test Procedure
 

The Lower Tester listens for Advertising Packets from the IUT.
- Expected Outcome
 

Pass verdict

At least one received Advertising Packet contains the defined Service UUID for «Location and Navigation Service».

### LNP/SEN/LNF/BV-02-C [Local Name included in AD or Scan Response]

- Test Purpose
 

Verify that the Local Name is included in AD (Advertising Data) or Scan Response data from the LN Sensor IUT when using the LE Transport.
- Reference
 

[3] 3.1.1.2
- Initial Condition
  - The IUT is powered on.
  - The IUT is induced to generate Advertising Packets using preamble 4.2.3.
- Test Procedure
 

The Lower Tester listens for Advertising Packets from the IUT. When the Lower Tester receives an Advertising Packet from the IUT, it sends a Scan Request to the IUT. Then the Lower Tester listens for a Scan Response from the IUT.

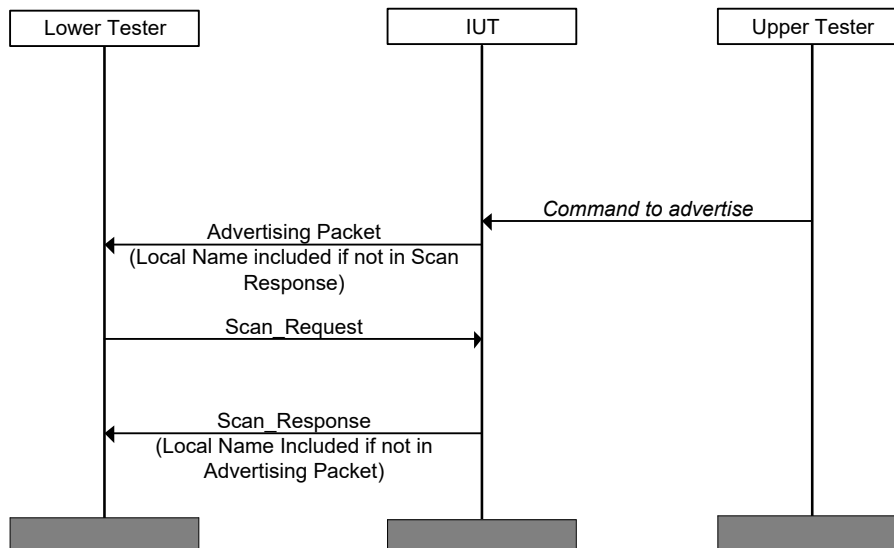

Figure 4.2: LNP/SEN/LNF/BV-02-C [Local Name included in AD or Scan Response]

- Expected Outcome

Pass verdict

The IUT sends an Advertising packet and a Scan Response packet.

The IUT includes the Local Name in either the Advertising packet or Scan Response packet, but not both.

### LNP/SEN/LNF/BV-03-C [Appearance included in AD or Scan Response]

- Test Purpose

Verify that the Appearance characteristic value is included in AD (Advertising Data) or Scan Response data from the LN Sensor IUT when using the LE Transport.

- Reference

[3] 3.1.1.4

- Initial Condition

- The IUT is powered on.
- The IUT is induced to generate Advertising Packets using preamble 4.2.3.

- Test Procedure

The Lower Tester listens for Advertising Packets from the IUT. When the Lower Tester receives an Advertising Packet from the IUT, it sends a Scan Request to the IUT. Then the Lower Tester listens for a Scan Response from the IUT.

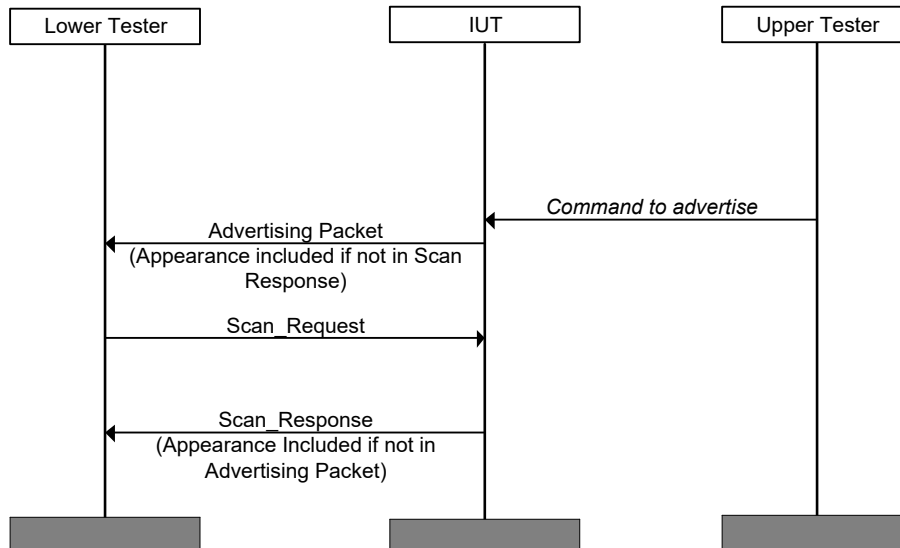

Figure 4.3: LNP/SEN/LNF/BV-03-C [Appearance included in AD or Scan Response]

- Expected Outcome

Pass verdict

The IUT sends an Advertising packet and a Scan Response packet.

The IUT includes the Appearance characteristic value in either the Advertising packet or Scan Response packet, but not both.

### LNP/COL/LNF/BI-01-C [LN Feature characteristic with reserved value]

- Test Purpose

Verify that the Collector IUT can read the LN Feature characteristic from an LN Sensor, and ignore reserved bits.

- Reference

[3] 4.4

- Initial Condition

- A preamble procedure defined in Section 4.2.4, if using an LE transport, or Section 4.2.5 if using a BR/EDR transport s used to setup the transport and L2CAP channel and initiate connection to an LN Sensor.
- The Upper Tester knows the handle of an LN Feature characteristic contained in the Lower Tester.

- Test Procedure

1. Send a command from Upper Tester to request the IUT to read an LN Feature Characteristic from the Lower Tester e.g., LNP\_ReadRequest (handle, value).
2. After receipt of the expected result by the Lower Tester from the IUT, send an ATT\_Read\_Response (0x0B) from the Lower Tester to the IUT containing values with some reserved bits set to 1.

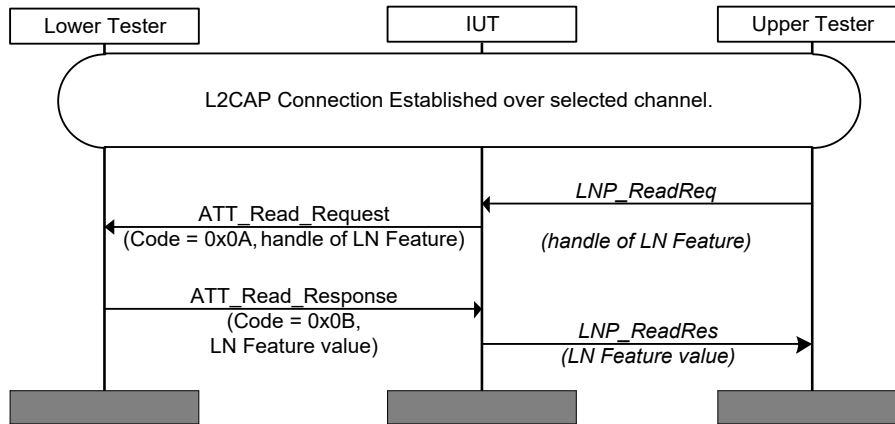

Figure 4.4: LNP/COL/LNF/BI-01-C [LN Feature characteristic with reserved value]

- Expected Outcome

Pass verdict

The IUT sends a correctly formatted *ATT\_Read\_Request* (0x0A) to the Lower Tester, containing the handle specified by the Upper Tester.

The IUT receives the response from the Lower Tester, ignores the reserved bits and continues to operate as if the reserved bits were not set.

### LNP/COL/LNF/BV-05-C [Configure Location and Speed for Notification]

- Test Purpose

Verify that the Collector IUT can configure an LN Sensor (Lower Tester) to notify Location and Speed characteristic.

- Reference

[3] 4.5

- Initial Condition

- A preamble procedure defined in Section 4.2.4, if using an LE transport, or Section 4.2.5 if using a BR/EDR transport is used to setup the transport and L2CAP channel and initiate connection to an LN Sensor.
- The IUT has discovered the Client Characteristic Configuration Descriptor for a Location and Speed characteristic contained in the Lower Tester.

- Test Procedure

The Upper Tester sends a command to the IUT to configure the LN Sensor to send Location and Speed characteristics.

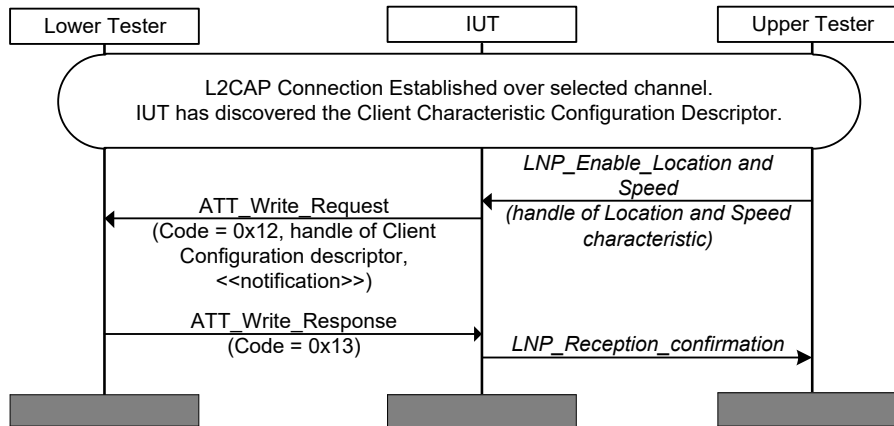

Figure 4.5: LNP/COL/LNF/BV-05-C [Configure Location and Speed for Notification]

- Expected Outcome

Pass verdict

The IUT sends a correctly formatted ATT\_Write\_Request (0x12) to the Lower Tester, with the handle set to that of the Client Characteristic Configuration Descriptor for a Location and Speed characteristic, and the value set to «notification».

**LNP/COL/LNF/BV-06-C [Receive Location and Speed Notifications]**

- Test Purpose

Verify that the Collector IUT can receive notifications of the Location and Speed Characteristic, including all variants.

- Reference

[3] 4.5

- Initial Condition

- A preamble procedure defined in Section 4.2.4, if using an LE transport, or Section 4.2.5 if using a BR/EDR transport is used to setup the transport and L2CAP channel and initiate connection to an LN Sensor.
- The IUT has executed the procedure included in LNP/COL/LNF/BV-05-C [Configure Location and Speed for Notification], which configures it to expect Location and Speed Notifications.
- The IUT knows the handle of the Location and Speed characteristic.

- Test Procedure

1. The Lower Tester sends an ATT\_Handle\_Value\_Notification containing a Location and Speed characteristic value to the IUT.
2. The Lower Tester sends one Location and Speed characteristic notification for each Test Pattern shown in the following table. For each Test Pattern, the value of the Flags field is shown along with the corresponding pass criteria.

Test Pattern	Flags Field Value (bit15 ... bit0)	Pass Criteria
1	00000000 – 00000001	Only optional field present is Instantaneous Speed with the Speed and Distance Format set to “2D”.
2	00000010 – 00000001	Only optional field present is Instantaneous Speed with the Speed and Distance Format set to “3D”.
3	00000000 – 00000010	Only optional field present is Total Distance with the Speed and Distance format set to “2D”.
4	00000010 – 00000010	Only optional field present is Total Distance with the Speed and Distance format set to “3D”.
5	00000000 – 00000100	Only optional field present is Location with Position Status set to “No Position”.
6	00000000 – 10000100	Only optional field present is Location with Position Status set to “Position OK”.
7	00000001 – 00000100	Only optional field present is Location with Position Status set to “Estimated”.
8	00000001 – 10000100	Only optional field present is Location with Position Status set to “Last Known Position”.
9	00000000 – 00001000	Only optional field present is Elevation with Elevation Source set to “Satellite Positioning System”..
10	00000100 – 00001000	Only optional field present is Elevation with Elevation Source set to “Barometric Air Pressure”
11	00001000 – 00001000	Only optional field present is Elevation with Elevation Source set to “Database Service (or similar)”.
12	00001100 – 00001000	Only optional field present is Elevation with Elevation Source set to “Other”.
13	00000000 – 00010000	Only optional field present is Heading with Heading Source set to “Heading based on movement”.
14	00010000 – 00010000	Only optional field present is Heading with Heading Source set to “Heading based on magnetic compass”.
15	00000000 – 00100000	Only optional field present is Rolling Time.
16	00000000 – 01000000	Only optional field present is UTC Time.
17	00000000 – 00000000	No optional fields are present.

Table 4.4: LNP/COL/LNF/BV-06-C [Receive Location and Speed Notifications]

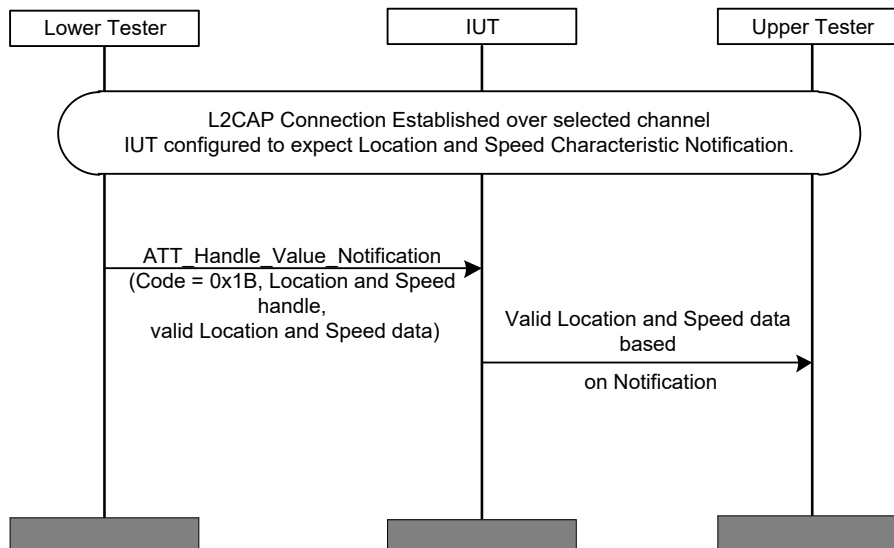

Figure 4.6: LNP/COL/LNF/BV-06-C [Receive Location and Speed Notifications]

- Expected Outcome

Pass verdict

The IUT is able to correctly parse the received Location and Speed values according to the pass criteria in the table above. The reported Location and Speed field values match the ones sent by the Lower Tester.

### LNP/COL/LNF/BV-07-C [Receive Location and Speed Notifications – Total Distance Roll Over]

- Test Purpose

Verify that the Collector IUT can receive notifications of the Location and Speed Characteristic and properly calculate total distance when the value of the Total Distance field rolls over.

- Reference

[3] 4.5

- Initial Condition

- A preamble procedure defined in Section 4.2.4, if using an LE transport, or Section 4.2.5 if using a BR/EDR transport is used to setup the transport and L2CAP channel and initiate connection to an LN Sensor.
- The IUT has executed the procedure included in LNP/COL/LNF/BV-05-C [Configure Location and Speed for Notification], which configures it to expect Location and Speed Notifications.
- The IUT knows the handle of the Location and Speed characteristic.

- Test Procedure
  1. Perform an action on the Lower Tester that induces it to set the Total Distance values in the table below such as to induce a Total Distance rollover event.

	Total Distance Value [ $10^{-1}m$ ]	Expected Total Distance Value IUT [ $10^{-1}m$ ]
1	16777214 (0xFFFFFE)	16777214
2	16777215 (0xFFFFF)	16777215
3	0 (0x000000)	16777216
4	1 (0x000001)	16777217
5	2 (0x000002)	16777218

2. The Lower Tester sends five ATT\_Handle\_Value\_Notifications containing a Location and Speed characteristic value to the IUT (corresponding to the sequence of rows in the table above) that simulate a regular and consistent distance accumulation as during an activity, including a Total Distance field roll over event.

- Expected Outcome

#### Pass verdict

The IUT receives notifications of Location and Speed values from the Lower Tester that include Total Distance field.

The IUT correctly calculates consistent accumulated total distance values before and after the roll over event.

### **LNP/COL/LNF/BV-08-C [Receive Speed and Location Notifications – Rolling Time Roll Over]**

- Test Purpose

Verify that the Collector IUT can receive notifications of the Location and Speed Characteristic and properly calculate speed when the value of the Rolling Time field rolls over.

- Reference

[3] 4.5

- Initial Condition

- A preamble procedure defined in Section 4.2.4, if using an LE transport, or Section 4.2.5 if using a BR/EDR transport is used to setup the transport and L2CAP channel and initiate connection to an LN Sensor.
- The IUT has executed the procedure included in [LNP/COL/LNF/BV-05-C \[Configure Location and Speed for Notification\]](#), which configures it to expect Location and Speed Notifications.
- The IUT knows the handle of the Location and Speed characteristic.

- Test Procedure
  1. Perform an action on the Lower Tester that induces it to set the Rolling Time values in the table below such as to induce a rollover event.

	Rolling time	Expected Accumulated Time at IUT [s]
1	254	254
2	255	255
3	0	256
4	1	257
5	2	258

2. The Lower Tester sends five ATT\_Handle\_Value\_Notifications containing a Location and Speed characteristic value to the IUT (corresponding to the sequence of rows in the table above) that simulate time accumulation, as during an activity, including a Rolling Time field roll over event.
  3. The IUT responds correctly when the Rolling Time value rolls over.
- Expected Outcome

Pass verdict

The IUT receives notifications of Location and Speed values from the Lower Tester that include Rolling Time Data.

The IUT correctly calculates consistent time values before and after the roll over event.

### LNP/COL/LNF/BI-02-C [Receive Location and Speed Notifications with reserved flags]

- Test Purpose
 

Verify that the Collector IUT can receive notifications of the Location and Speed Characteristic from an LN Sensor including reserved flags.
- Reference
 

[3] 4.5
- Initial Condition
  - A preamble procedure defined in Section 4.2.4, if using an LE transport, or Section 4.2.5 if using a BR/EDR transport is used to setup the transport and L2CAP channel and initiate connection to an LN Sensor.
  - The IUT has executed the procedure included in LNP/COL/LNF/BV-05-C [Configure Location and Speed for Notification], which configures it to expect Location and Speed Notifications.
  - The IUT knows the handle of the Location and Speed characteristic.
- Test Procedure
 

The Lower Tester sends an ATT\_Handle\_Value\_Notification containing a Location and Speed characteristic value to the IUT. There are many combinations of reserved flag settings. For this test use Flags = 0xE000. This includes reserved bits 15, 14 and 13 = 111. Optional fields are not present in the Location and Speed characteristic, so other bits of the Flags field are set to 0 as well as all of the configuration and status bits.

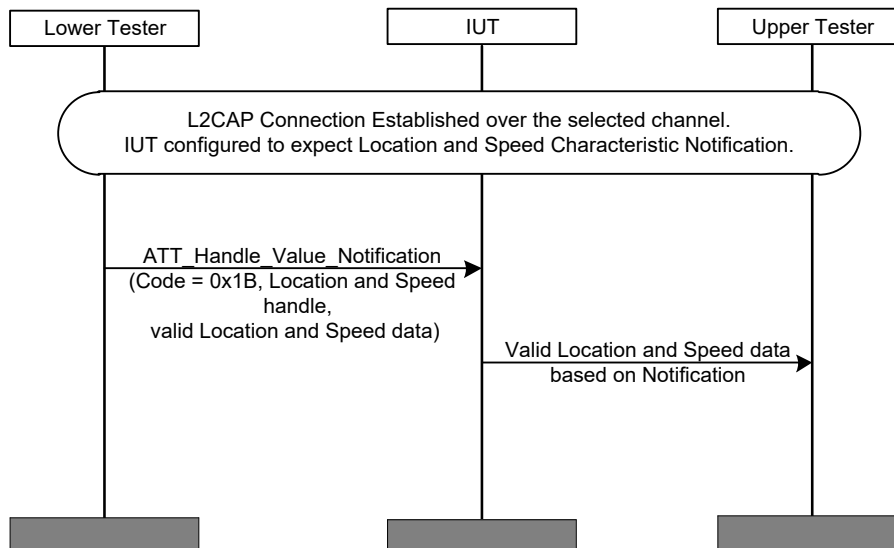

Figure 4.7: LNP/COL/LNF/BI-02-C [Receive Location and Speed Notifications with reserved flags]

- Expected Outcome

Pass verdict

The IUT reports the received Location and Speed value to the Upper Tester. The reported Location and Speed value matches the one sent by the Lower Tester, including the reserved bits of the Flags field.

### LNP/COL/LNF/BI-03-C [Receive Location and Speed Notifications with additional octets not represented in the flags field]

- Test Purpose

Verify that the Collector IUT can receive notifications of the Location and Speed Characteristic from an LN Sensor including additional octets not represented in the flags field.

- Reference

[3] 4.5

- Initial Condition

- A preamble procedure defined in Section 4.2.4, if using an LE transport, or Section 4.2.5 if using a BR/EDR transport is used to setup the transport and L2CAP channel and initiate connection to an LN Sensor.
- The IUT has executed the procedure included in LNP/COL/LNF/BV-05-C [Configure Location and Speed for Notification], which configures it to expect Location and Speed Notifications.
- The IUT knows the handle of the Location and Speed characteristic.

- Test Procedure

The Lower Tester sends an ATT\_Handle\_Value\_Notification containing a Location and Speed characteristic value to the IUT. That value contains only flags field with value 0x0001 and Instantaneous Speed. Other optional fields are not present, and at least two additional octets not represented in the flags field are present. The total number of octets does not exceed the maximum MTU size.

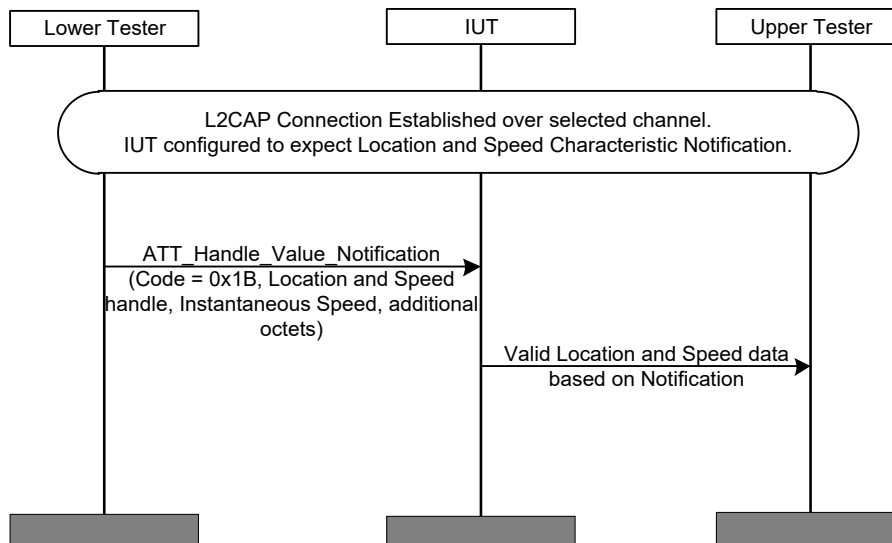

Figure 4.8: LNP/COL/LNF/BI-03-C [Receive Location and Speed Notifications with additional octets not represented in the flags field]

- Expected Outcome

Pass verdict

The IUT reports the received Location and Speed value to the Upper Tester with no additional octets. The reported Location and Speed value matches the one sent by the Lower Tester.

### LNP/COL/LNF/BV-09-C [Read Position Quality characteristic]

- Test Purpose

Verify that the Collector IUT can read the Position Quality characteristic from an LN Sensor.

- Reference

[3] 4.6

- Initial Condition

- A preamble procedure defined in Section 4.2.4, if using an LE transport, or Section 4.2.5 if using a BR/EDR transport is used to setup the transport and L2CAP channel and initiate connection to an LN Sensor.
- The Upper Tester knows the handle of a Position Quality characteristic contained in the Lower Tester.

- Test Procedure

1. Send a command from the Upper Tester to request the IUT to read a Position Quality characteristic from the Lower Tester e.g., LNP\_ReadRequest (handle, value).
2. After receipt of the expected result by the Lower Tester from the IUT, send an ATT\_Read\_Response (0x0B) from the Lower Tester to the IUT containing a defined value of the Position Quality characteristic.
3. The Position Quality characteristic is read for each Test Pattern shown in the following table. For each Test Pattern, the value of the Flags field is shown along with the corresponding pass criteria.

Test Pattern	Flags Field Value (bit15 ... bit0)	Pass Criteria
1	00000000 – 00000000	No optional fields are present, Position status set to: "No Position".
2	00000000 – 10000000	No optional fields are present, Position status set to: "Position OK".
3	00000001 – 00000000	No optional fields are present, Position status set to: "Estimated".
4	00000001 – 10000000	No optional fields are present, Position status set to: "Last Known Position".
5	00000000 – 00000001	Only optional field present is Number of Satellites in Solution.
6	00000000 – 00000010	Only optional field present is Number of Satellites in View.
7	00000000 – 00000100	Only optional field present is Time to First Fix.
8	00000000 – 00001000	Only optional field present is Estimated Horizontal Position Error (EHPE).
9	00000000 – 00010000	Only optional field present is Estimated Vertical Position Error (EVPE).
10	00000000 – 00100000	Only optional field present is Horizontal Dilution of Precision (HDOP).
11	00000000 – 01000000	Only optional field present is Vertical Dilution of Precision (VDOP).
12	00000000 – 01111111	All optional fields are present: Number of Satellites in Solution, Number of Satellites in View, Time to First Fix, EHPE, EVPE, HDOP, VDOP.

Table 4.5: LNP/COL/LNF/BV-09-C [Read Position Quality characteristic]

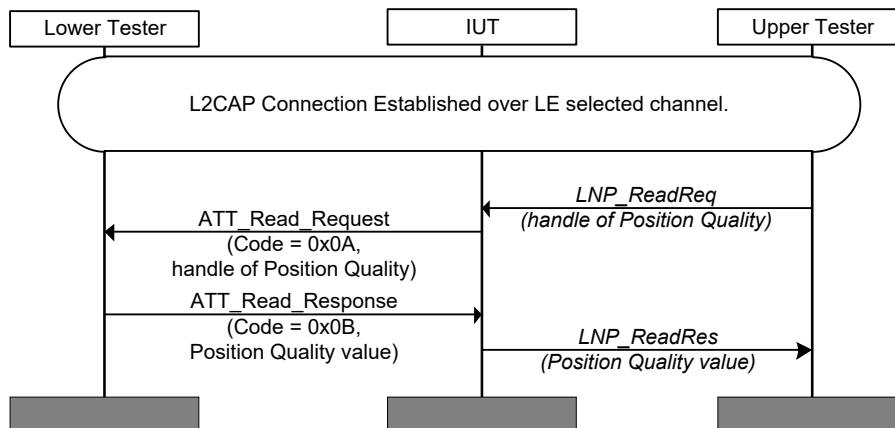

Figure 4.9: LNP/COL/LNF/BV-09-C [Read Position Quality characteristic]

- Expected Outcome

Pass verdict

The IUT sends a correctly formatted ATT\_Read\_Request (0x0A) to the Lower Tester, containing the handle specified by the Upper Tester, as in the pass criteria specified in the table above.

The IUT receives the response from the Lower Tester and sends the LNP\_ReadResponse containing the correct Position Quality value to the Upper Tester.



**LNP/COL/LNF/BI-04-C [Read Position Quality characteristic with reserved value]**

- Test Purpose

Verify that the Collector IUT can read the Position Quality characteristic from an LN Sensor and discard a reserved value or change it to 'Other'.

- Reference

[3] 4.6

- Initial Condition

- A preamble procedure defined in Section 4.2.4, if using an LE transport, or Section 4.2.5 if using a BR/EDR transport is used to setup the transport and L2CAP channel and initiate connection to an LN Sensor.
- The Upper Tester knows the handle of a Position Quality characteristic contained in the Lower Tester.

- Test Procedure

1. Send a command from the Upper Tester to request the IUT to read a Position Quality characteristic from the Lower Tester e.g., LNP\_ReadRequest (handle, value).
2. After receipt of the expected result by the Lower Tester from the IUT, send an ATT\_Read\_Response (0x0B) from the Lower Tester to the IUT containing a reserved value.

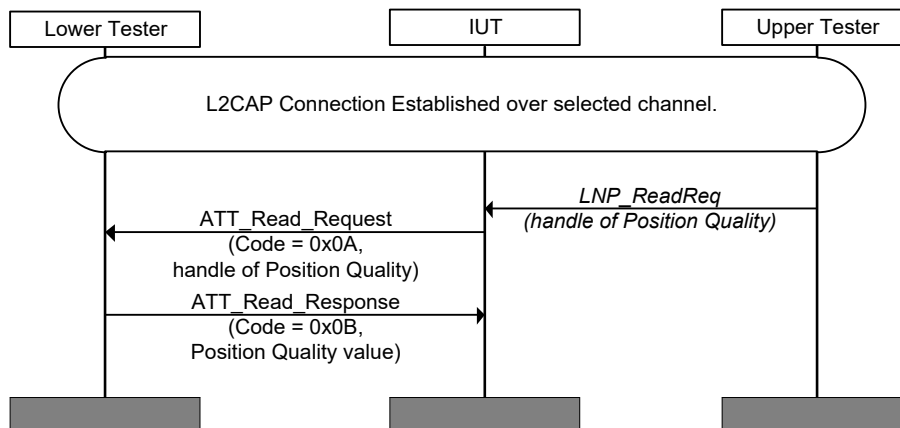

Figure 4.10: LNP/COL/LNF/BI-04-C [Read Position Quality characteristic with reserved value]

- Expected Outcome

Pass verdict

The IUT sends a correctly formatted ATT\_Read\_Request (0x0A) to the Lower Tester, containing the handle specified by the Upper Tester.

The IUT receives the response from the Lower Tester and discards it or changes it to 'Other'.

**LNP/COL/LNF/BV-10-C [Configure Navigation for Notification]**

- Test Purpose

Verify that the Collector IUT can configure an LN Sensor (Lower Tester) to notify Navigation characteristics.

- Reference

[3] 4.7 and 4.8

- Initial Condition

- A preamble procedure defined in Section 4.2.4, if using an LE transport, or Section 4.2.5 if using a BR/EDR transport is used to setup the transport and L2CAP channel and initiate connection to an LN Sensor.
- The IUT has discovered the Client Characteristic Configuration Descriptor for a Navigation characteristic contained in the Lower Tester.

- Test Procedure

The Upper Tester sends a command to the IUT to configure the LN Sensor to receive Navigation characteristics.

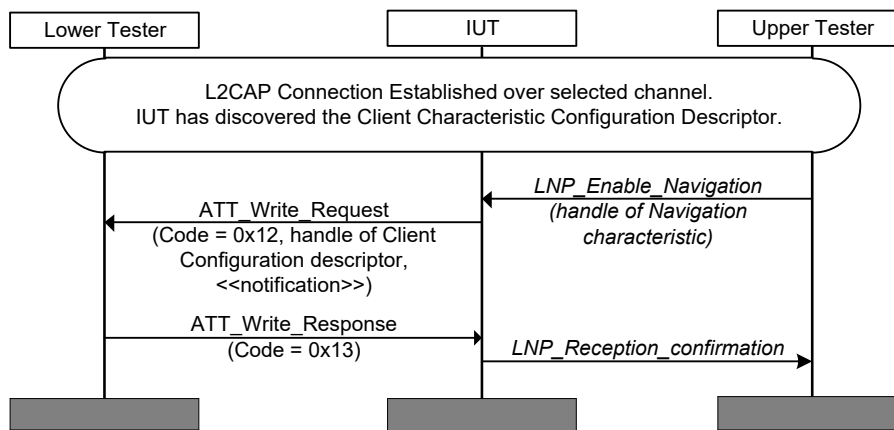

Figure 4.11: LNP/COL/LNF/BV-10-C [Configure Navigation for Notification]

- Expected Outcome

Pass verdict

The IUT sends a correctly formatted *ATT\_Write\_Request* (0x12) to the Lower Tester, with the handle set to that of the Client Characteristic Configuration Descriptor for a Navigation characteristic, and the value set to «notification».

### LNP/COL/LNF/BV-11-C [Receive Navigation Notifications]

- Test Purpose

Verify that the Collector IUT can receive notifications of the Navigation Characteristic, including all variants.

- Reference

[3] 4.7 and 4.8

- Initial Condition
  - A preamble procedure defined in Section 4.2.4, if using an LE transport, or Section 4.2.5 if using a BR/EDR transport is used to setup the transport and L2CAP channel and initiate connection to an LN Sensor.
  - The IUT has executed the procedure included in [LNP/COL/LNF/BV-10-C \[Configure Navigation for Notification\]](#), which configures it to expect Navigation Notifications.
  - The IUT knows the handle of the Navigation characteristic.
- Test Procedure
  1. The Lower Tester sends an ATT\_Handle\_Value\_Notification containing a Navigation characteristic value to the IUT.
  2. The Lower Tester sends one Navigation characteristic notification for each Test Pattern shown in the following table. For each Test Pattern, the value of the Flags field is shown along with the corresponding pass criteria.

Test Pattern	Flags Field Value (bit15 ... bit0)	Pass Criteria
1	00000000 – 00000001	Only optional field present is Remaining Distance, with Navigation Indicator Type set to “to Waypoint”.
2	00000000 – 01000001	Only optional field present is Remaining Distance, with Navigation Indicator Type set to “to Destination”.
3	00000000 – 00000010	Only optional field present is Remaining Vertical Distance, with Navigation Indicator Type set to “to Waypoint”.
4	00000000 – 01000010	Only optional field present is Remaining Vertical Distance, with Navigation Indicator Type set to “to Destination”.
5	00000000 – 00000100	Only optional field present is Estimated Time of Arrival, with Navigation Indicator Type set to “to Waypoint”.
6	00000000 – 01000100	Only optional field present is Estimated Time of Arrival, with Navigation Indicator Type set to “to Destination”.
7	00000000 – 00000000	Only mandatory fields are present, with Position Status set to: “No position”, Heading Source set to “Heading based on movement”, Navigation Indicator Type set to “To Waypoint”, Waypoint reached set to “False”, Destination reached set to “False”.
8	00000000 – 00001000	Only mandatory fields are present, with Position Status set to: “Position OK”.
9	00000000 – 00010000	Only mandatory fields are present, with Position Status set to: “Estimated”.
10	00000000 – 00011000	Only mandatory fields are present, with Position Status set to: “Last Known Position”.
11	00000000 – 00100000	Only mandatory fields are present with Heading Source set to: “Heading based on magnetic compass”.

Test Pattern	Flags Field Value (bit15 ... bit0)	Pass Criteria
12	00000000 – 10000000	Only mandatory fields are present with Waypoint reached set to: “True”.
13	00000001 – 00000000	Only mandatory fields are present with Destination reached set to: “True”.

Table 4.6: LNP/COL/LNF/BV-11-C [Receive Navigation Notifications]

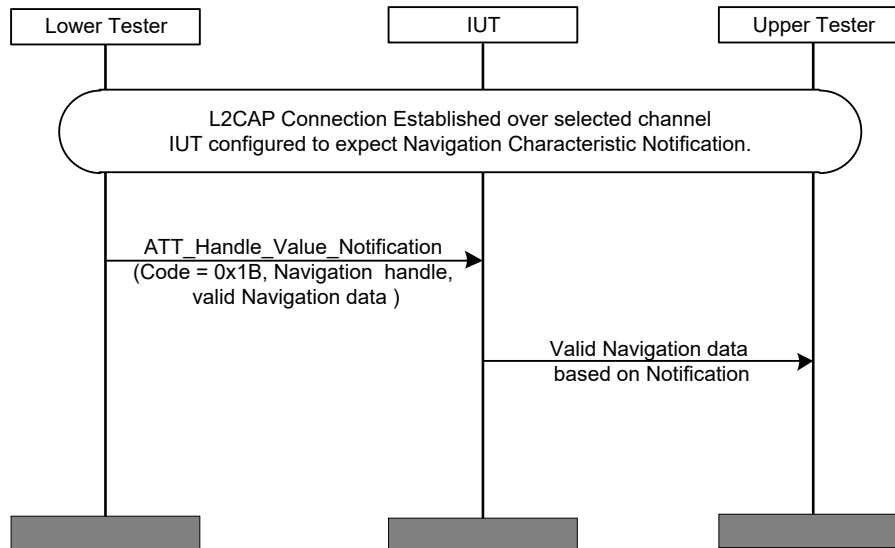

Figure 4.12: LNP/COL/LNF/BV-11-C [Receive Navigation Notifications]

- Expected Outcome

#### Pass verdict

The IUT is able to correctly parse the received Navigation values according to the pass criteria in the table above. The reported Navigation field values match the ones sent by the Lower Tester.

### LNP/COL/LNF/BI-05-C [Receive Navigation Notifications with reserved flags]

- Test Purpose

Verify that the Collector IUT can receive notifications of the Navigation Characteristic from an LN Sensor including reserved flags.

- Reference

[3] 4.7 and 4.8

- Initial Condition

- A preamble procedure defined in Section 4.2.4, if using an LE transport, or Section 4.2.5 if using a BR/EDR transport is used to setup the transport and L2CAP channel and initiate connection to an LN Sensor.
- The IUT has executed the procedure included in [LNP/COL/LNF/BV-11-C \[Receive Navigation Notifications\]](#), which configures it to expect Navigation Notifications.
- The IUT knows the handle of the Navigation characteristic.

- Test Procedure

The Lower Tester sends an ATT\_Handle\_Value\_Notification containing a Navigation characteristic value to the IUT. There are many combinations of reserved flag settings. For this test use Flags = 0xFE02. This includes reserved bits from 9–15. Only optional field present in the Navigation characteristic is the Remaining Vertical Distance. So the bit 1 of the Flags field is set to 1 and the other bits are set to 0.

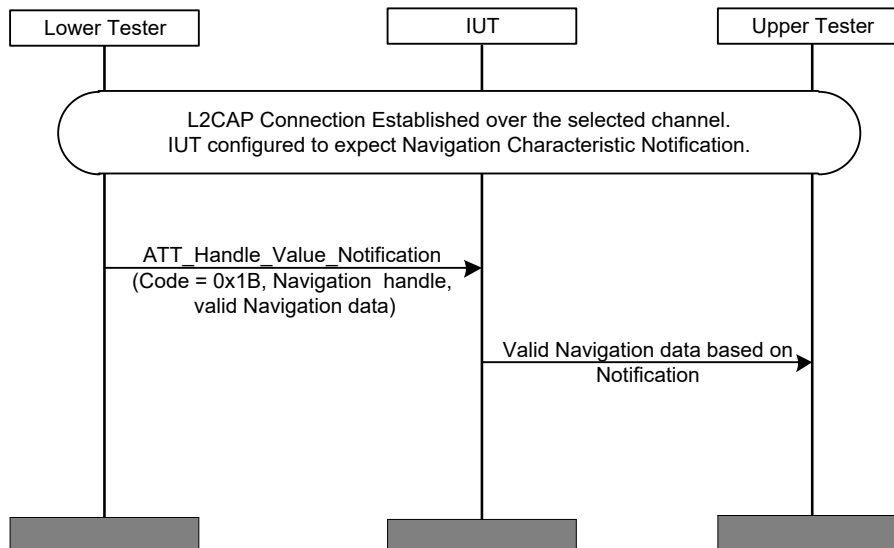

Figure 4.13: LNP/COL/LNF/BI-05-C [Receive Navigation Notifications with reserved flags]

- Expected Outcome

Pass verdict

The IUT reports the received Navigation value to the Upper Tester. The reported Navigation value matches the one sent by the Lower Tester, including the reserved bits of the Flags field.

### LNP/COL/LNF/BV-12-C [Lost Bond Procedure when using LE Transport]

- Test Purpose

Verify that the Collector IUT starts encryption with a bonded LN Sensor on reconnection and rediscovers and reconfigures LN Sensor if bond is lost.

- Reference

[3] 5.2.1

- Initial Condition

- The IUT and the Lower Tester have been previously bonded.
- The IUT has configured the Lower Tester to enable notifications on the Location and Navigation characteristic of the Lower Tester's Location and Navigation Service.
- The Lower Tester has the «Service Changed» characteristic.
- No connection is established between the IUT and Lower Tester.
- The bond is deleted at the Lower Tester.

- Test Procedure
  1. The Lower Tester begins advertising using GAP undirected connectable mode.
  2. The IUT establishes a connection to the Lower Tester.
  3. The Lower Tester does not send any notifications to the IUT.
  4. The IUT starts encryption when the connection is established and rediscovers and reconfigures the LN Sensor upon detection of the lost bond.

- Expected Outcome

Pass verdict

The IUT starts encryption when the connection is established.

The IUT rediscovers the Location and Navigation Service.

The IUT reconfigures the Client Characteristic Configuration descriptors of the Location and Speed characteristic, the LN Control Point characteristic and the Navigation Characteristic (if supported).

### **LNP/COL/LNF/BV-13-C [Lost Bond Procedure when using BR/EDR transport]**

- Test Purpose

Verify that the Collector IUT reconfigures the LN Sensor if the bond is lost.

Verify that the paging device starts encryption with a bonded page scanning device on reconnection.

- Reference

[3] 5.3.2

- Initial Condition

- The IUT and the Lower Tester have previously bonded.
- The IUT has configured the Lower Tester to enable notifications on the Location and Speed characteristic of the Lower Tester's Location and Navigation Service.
- The Lower Tester has the «Service Changed» characteristic.
- No connection is established between the IUT and Lower Tester.
- The bond is deleted at the Lower Tester.

- Test Procedure

1. The page scanning device is in connectable mode.
2. The paging device establishes a connection to the page scanning device.
3. The Lower Tester does not send any notifications to the IUT.
4. The Central starts encryption when the connection is established.
5. The IUT rediscovers and reconfigures the LN Sensor upon detection of the lost bond.

- Expected Outcome

Pass verdict

The Central starts encryption when the connection is established.

The IUT rediscovers the Location and Navigation Service.

The IUT reconfigures the Client Characteristic Configuration descriptors of the Location and Speed characteristic, the LN Control Point characteristic and the Navigation Characteristic (if supported).

### LNP/COL/LNF/BV-14-C [Read LN Feature Characteristic with Bonding Enabled]

- Test Purpose

Verify that, after the initial connection and bonding, the Collector IUT can read the LN Feature characteristic.
- Reference

[12] 4.4
- Initial Condition
  - Establish an ATT Bearer connection between the Lower Tester and IUT as described in Section 4.2.1 if using an LE transport, or Section 4.2.2 if using a BR/EDR transport.
  - The IUT is bonded with the Lower Tester.
  - The Upper Tester knows the handle of the LN Feature characteristic contained in the Lower Tester.
- Test Procedure
  1. The Upper Tester commands the IUT to read the LN Feature characteristic from the Lower Tester.
  2. The IUT sends an ATT\_Read\_Request to the Lower Tester containing the handle specified by the Upper Tester.
  3. The Lower Tester receives the ATT\_Read\_Request and then sends an ATT\_Read\_Response to the IUT containing the value of the characteristic.
  4. The IUT receives the ATT\_Read\_Response and reports the value to the Upper Tester.
- Expected Outcome

Pass verdict

The IUT reads the LN Feature characteristic and reports its value to the Upper Tester.

Reserved for future use bit values are ignored.

### LNP/COL/LNF/BV-15-C [Enable LN Feature Characteristic for Indication or Read Feature Characteristic Upon Reconnection]

- Test Purpose

Verify that the Collector IUT can either enable the LN Feature characteristic for indication or read the LN Feature characteristic upon reconnection.
- Reference

[12] 4.4
- Initial Condition
  - The handles of the LN Feature characteristic and Client Characteristic Configuration descriptor have been previously discovered by the Upper Tester during the test procedures in Section 4.3.1 or are known to the Upper Tester by other means.
  - Establish an ATT Bearer connection between the Lower Tester and IUT as described in Section 4.2.1 if using an LE transport, or Section 4.2.2 if using a BR/EDR transport.
  - The IUT is not paired and bonded with the Lower Tester.

- Test Procedure
  1. The Upper Tester orders the IUT to initiate pairing and bonding.
  2. The Upper Tester commands the IUT to perform either alternative 2A or 2B:  
Alternative 2A (Configure the LN Feature characteristic for indication):
    - 2A.1. The IUT configures the LN Feature characteristic for indication.

Or,

Alternative 2B (Read the LN Feature characteristic upon reconnection):

    - 2B.1. The Upper Tester commands the IUT to disconnect, and the IUT terminates the connection with the Lower Tester.
    - 2B.2. The Upper Tester commands the IUT to reconnect to the Lower Tester.
    - 2B.3. The IUT reads the LN Feature characteristic from the Lower Tester and reports the value to the Upper Tester.

- Expected Outcome

Pass verdict

In step 1, the IUT successfully completes pairing and bonding.

In step 2A.1, the IUT enables the LN Feature characteristic for indication.

In step 2B.3, the IUT reads the LN Feature characteristic and reports its value to the Upper Tester.

Reserved for future use bit values are ignored.

## 4.6 Service Procedures – Set Cumulative Value

This test group contains test cases to verify compliant operation when the LN Control Point Set Cumulative Value procedure is used.

### LNP/COL/SPS/BV-01-C [Set Cumulative Value – Set to zero]

- Test Purpose
 

Verify that the Collector IUT can perform the Set Cumulative Value procedure to set a zero value.
- Reference
 

[3] 4.7.2.1
- Initial Condition
  - Perform the preamble described in Section 4.2.3.
  - The value of Total Distance in the Lower Tester is set to a known non-zero value.
- Test Procedure
  1. A connection is established between the IUT and Lower Tester using the Preamble defined in Section 4.2.4, if using an LE transport, or Section 4.2.5 if using a BR/EDR transport.
  2. The Lower Tester sends one or more notifications of the Location and Speed characteristic with the Total Distance field set to a non-zero value.
  3. The IUT writes the Set Cumulative Value Op Code (0x01) to the LN Control Point with a Parameter Value of 0x000000.

4. The Lower Tester sends an indication of the LN Control Point characteristic with the Response Code Op Code (0x20) and a Parameter representing Request Op Code (0x01) followed by the Response Code for 'success' (0x01).
5. The Lower Tester sends a notification of the Location and Speed characteristic with the Total Distance field set to 0 (or close to 0).

- Expected Outcome

Pass verdict

The IUT receives one or more notifications of the Location and Speed characteristic with the Total Distance field set to a non-zero value.

After setting the value to zero, the IUT receives the next notification of the Location and Speed characteristic containing the Total Distance field with the value of the Total Distance field set to 0 (or slightly higher in case of movement).

### LNP/COL/SPS/BV-02-C [Set Cumulative Value – Set to non-zero]

- Test Purpose

Verify that the Collector IUT can perform the Set Cumulative Value procedure to set a non-zero value.

- Reference

[3] 4.7.2.1

- Initial Condition

- Perform the preamble described in Section 4.2.3.
- The value of Total Distance in the Lower Tester is set to a known value.

- Test Procedure

1. A connection is established between the IUT and Lower Tester using the Preamble defined in Section 4.2.4, if using an LE transport, or Section 4.2.5 if using a BR/EDR transport.
2. The Lower Tester sends one or more notifications of the Location and Speed characteristic with the Total Distance field set to any value.
3. The IUT writes the Set Cumulative Value Op Code (0x01) to the LN Control Point with a Parameter Value that is a different than the initial value (e.g., 0x00FFFF).
4. The Lower Tester sends an indication of the LN Control Point characteristic with the Response Code Op Code (0x20) and a Parameter representing Request Op Code (0x01) followed by the Response Code for 'success' (0x01).
5. The Lower Tester sends a notification of the Location and Speed characteristic with the Total Distance field set to the specified value (or close to the specified value).

- Expected Outcome

Pass verdict

The IUT receives one or more notifications of the Location and Speed characteristic with the Total Distance field set to the specified non-zero value.

After setting the value, the IUT receives the next notification of the Location and Speed characteristic containing the Total Distance field with the value of the Total Distance field set to the specified value (or slightly higher in case of movement).

## 4.7 Service Procedure – Mask Characteristic Content

### LNP/COL/SPM/BV-01-C [Mask Location and Speed Characteristic Content]

- Test Purpose
 

Verify that the Collector IUT can perform the Mask Location and Speed Characteristic Content procedure.
- Reference
 

[3] 4.7.2.2
- Initial Condition
  - Perform the preamble described in Section 4.2.3.
- Test Procedure
  1. A connection is established between the IUT and Lower Tester using the Preamble defined in Section 4.2.4, if using an LE transport, or Section 4.2.5 if using a BR/EDR transport.
  2. The IUT writes the Mask Location and Speed Characteristic Content Op Code (0x02) to the LN Control Point with a Parameter Value set to a valid mask value (UINT16).
  3. The Lower Tester sends an indication of the LN Control Point characteristic with the Response Code Op Code (0x20) and a Parameter representing Request Op Code (0x02) followed by the Response Code for 'success' (0x01).
  4. The IUT sends ATT\_Handle\_Value\_Confirmation to the Lower Tester.
  5. The Lower Tester sends one or more ATT\_Handle\_Value\_Notifications of the Location and Speed characteristic with the masked fields not present.
- Expected Outcome
 

Pass verdict

The mask value is updated with the correct value.

The IUT receives the Request Op Code 'success'.

## 4.8 Service Procedures – Navigation Control

### LNP/COL/SPN/BV-01-C [Request Number of Routes]

- Test purpose
 

Verify that the Collector IUT can perform the Request Number of Routes procedure.
- Reference
 

[3] 4.7.2.4
- Initial Condition
  - Perform the preamble described in Section 4.2.3.
- Test Procedure
  1. A connection is established between the IUT and Lower Tester using the Preamble defined in Section 4.2.4, if using an LE transport, or Section 4.2.5 if using a BR/EDR transport.
  2. The IUT writes the Request Number of Routes Op Code (0x04) to the LN Control Point without Parameter.

3. The Lower Tester sends an indication of the LN Control Point characteristic with the Response Code Op Code (0x20) and a Parameter representing the Request Op Code (0x04), the Response Code for 'success' (0x01) followed by the number of available routes (UINT16).
4. The IUT sends ATT\_Handle\_Value\_Confirmation to the Lower Tester.

- Expected Outcome

Pass verdict

The IUT receives valid value for number of routes.

### LNP/COL/SPN/BV-02-C [Request Name of Route]

- Test Purpose

Verify that the Collector IUT can perform the Request Name of Route procedure.

- Reference

[3] 4.7.2.5

- Initial Condition

- Perform the preamble described in Section 4.2.3.

- Test Procedure

1. A connection is established between the IUT and Lower Tester using the Preamble defined in Section 4.2.4, if using an LE transport, or Section 4.2.5 if using a BR/EDR transport.
2. The IUT writes the Request Name of Route Op Code (0x05) to the LN Control Point with a parameter value set to valid route number (UINT16). Valid route number is a number from 0 to number of routes – 1. Number of routes can be obtained by executing the procedure included in LNP/COL/SPN/BV-01-C [Request Number of Routes], or by other means.
3. The Lower Tester sends an indication of the LN Control Point characteristic with the Response Code Op Code (0x20) and a Parameter representing the Request Op Code (0x05), the Response Code for 'success' (0x01) followed by the name of route (UTF-8 string).
4. The IUT sends ATT\_Handle\_Value\_Confirmation to the Lower Tester.

- Expected Outcome

Pass verdict

The IUT receives valid route name.

### LNP/COL/SPN/BV-03-C [Select Route]

- Test Purpose

Verify that the Collector IUT can perform the Select Route procedure.

- Reference

[3] 4.7.2.6

- Initial Condition

- Perform the preamble described in Section 4.2.3.

- Test Procedure
  1. A connection is established between the IUT and Lower Tester using the Preamble defined in Section 4.2.4, if using an LE transport, or Section 4.2.5 if using a BR/EDR transport.
  2. The IUT writes the Select Route Op Code (0x06) to the LN Control Point with a parameter value set to valid route number (UINT16). Valid route number is a number from 0 to number of routes – 1. Number of routes can be obtained by executing the procedure included in [LNP/COL/SPN/BV-01-C \[Request Number of Routes\]](#), or by other means.
  3. The Lower Tester sends an indication of the LN Control Point characteristic with the Response Code Op Code (0x20) and a Parameter representing the Request Op Code (0x06), the Response Code for 'success' (0x01) without response parameter.
  4. The IUT sends ATT\_Handle\_Value\_Confirmation to the Lower Tester.

- Expected Outcome

Pass verdict

The IUT receives the Request Op Code 'success'

### **LNP/COL/SPN/BV-04-C [Navigation Control – Start]**

- Test Purpose
 

Verify that the Collector IUT supports the Navigation feature.
- Reference
 

[\[3\] 4.7.2.3](#)
- Initial Condition
  - Perform the preamble described in Section [4.2.3](#).
- Test Procedure
  1. A connection is established between the IUT and Lower Tester using the Preamble defined in Section 4.2.4, if using an LE transport, or Section 4.2.5 if using a BR/EDR transport.
  2. The IUT has executed the procedure included in [LNP/COL/SPN/BV-03-C \[Select Route\]](#) to select route for Navigation.
  3. The IUT writes the Navigation Control Op Code (0x03) to the Navigation Control Point with a Parameter Value set to 0x01 (Start).
  4. The Lower Tester sends an indication of the LN Control Point characteristic with the Response Code Op Code (0x20) and a Parameter representing Request Op Code (0x03) followed by the Response Code for 'success' (0x01).
  5. The IUT sends ATT\_Handle\_Value\_Confirmation to the Lower Tester.
  6. The IUT receives one or more notifications of the Navigation characteristic.

- Expected Outcome

Pass verdict

When the IUT starts the notifications of the Navigation characteristic, it receives and processes these notifications as expected.

The IUT receives the Request Op Code 'success' when it starts the notifications of the Navigation characteristic.

## LNP/COL/SPN/BV-05-C [Navigation Control – Stop]

- Test Purpose

Verify that the Collector IUT supports the Navigation feature.
- Reference

[3] 4.7.2.3
- Initial Condition
  - Perform the preamble described in Section 4.2.3.
- Test Procedure
  1. A connection is established between the IUT and Lower Tester using the Preamble defined in Section 4.2.4, if using an LE transport, or Section 4.2.5 if using a BR/EDR transport.
  2. The IUT has executed the procedure included in LNP/COL/SPN/BV-04-C [Navigation Control – Start] to request the sending of the Navigation notifications.
  3. The IUT receives one or more notifications of the Navigation characteristic.
  4. The IUT writes the Navigation Control Op Code (0x03) to the LN Control Point with a Parameter Value set to 0x00 (Stop).
  5. The Lower Tester sends an indication of the LN Control Point characteristic with the Response Code Op Code (0x20) and a Parameter representing Request Op Code (0x03) followed by the Response Code for 'success' (0x01).
  6. The IUT sends ATT\_Handle\_Value\_Confirmation to the Lower Tester.
- Expected Outcome

Pass verdict

When the IUT starts the notifications of the Navigation characteristic, it receives and processes these notifications as expected.

When the IUT stops the notifications of the Navigation characteristic, it stops receiving notifications.

The IUT receives the Request Op Code 'success' when it starts and stops the notifications of the Navigation characteristic.

## LNP/COL/SPN/BV-06-C [Navigation Control – Pause and Continue]

- Test Purpose

Verify that the Collector IUT supports the Navigation feature.
- Reference

[3] 4.7.2.3
- Initial Condition
  - Perform the preamble described in Section 4.2.3.
- Test Procedure
  1. A connection is established between the IUT and Lower Tester using the Preamble defined in Section 4.2.4, if using an LE transport, or Section 4.2.5 if using a BR/EDR transport.
  2. The IUT has executed the procedure included in LNP/COL/SPN/BV-04-C [Navigation Control – Start] to request the sending of the Navigation notifications.
  3. The IUT receives one or more notifications of the Navigation characteristic.

4. The IUT writes the Navigation Control Op Code (0x03) to the LN Control Point with a Parameter Value set to 0x02 (Pause).
  5. The Lower Tester sends an indication of the LN Control Point characteristic with the Response Code Op Code (0x20) and a Parameter representing Request Op Code (0x03) followed by the Response Code for 'success' (0x01).
  6. The IUT sends ATT\_Handle\_Value\_Confirmation to the Lower Tester.
  7. The IUT stops receiving notifications of the Navigation characteristic.
  8. The IUT writes the Navigation Control Op Code (0x03) to the Navigation Control Point with a Parameter Value set to 0x03 (Continue).
  9. The Lower Tester sends an indication of the LN Control Point characteristic with the Response Code Op Code (0x20) and a Parameter representing Request Op Code (0x03) followed by the Response Code for 'success' (0x01).
  10. The IUT sends ATT\_Handle\_Value\_Confirmation to the Lower Tester.
  11. The IUT receives one or more notifications of the Navigation characteristic.
  12. The IUT writes the Navigation Control Op Code (0x03) to the LN Control Point with a Parameter Value set to 0x00 (Stop).
  13. The Lower Tester sends an indication of the LN Control Point characteristic with the Response Code Op Code (0x20) and a Parameter representing Request Op Code (0x03) followed by the Response Code for 'success' (0x01).
  14. The IUT sends ATT\_Handle\_Value\_Confirmation to the Lower Tester.
- Expected Outcome

#### Pass verdict

When the IUT starts the notifications of the Navigation characteristic, it receives and processes these notifications as expected.

When the IUT pauses the navigation and thus stops the notifications of the Navigation characteristic, it stops receiving notifications.

When the IUT continues the navigation and thus restarts the notifications of the Navigation characteristic, it receives and processes these notifications as expected.

When the IUT stops the navigation and the notifications of the Navigation characteristic, it stops receiving notifications.

The IUT receives the Request Op Code 'success' when it starts, pauses, continues and stops the navigation.

### LNP/COL/SPN/BV-07-C [Navigation Control – Skip Waypoint]

- Test Purpose
 

Verify that the Collector IUT supports the Navigation feature.
- Reference
 

[3] 4.7.2.3
- Initial Condition
  - Perform the preamble described in Section 4.2.3.

- Test Procedure
  1. A connection is established between the IUT and Lower Tester using the Preamble defined in Section 4.2.4, if using an LE transport, or Section 4.2.5 if using a BR/EDR transport.
  2. The IUT has executed the procedure included in [LNP/COL/SPN/BV-03-C \[Select Route\]](#) to select route for Navigation.
  3. The IUT writes the Navigation Control Op Code (0x03) to the Navigation Control Point with a Parameter Value set to 0x01 (Start).
  4. The Lower Tester sends an indication of the LN Control Point characteristic with the Response Code Op Code (0x20) and a Parameter representing Request Op Code (0x03) followed by the Response Code for 'success' (0x01).
  5. The IUT sends ATT\_Handle\_Value\_Confirmation to the Lower Tester.
  6. The IUT receives one or more notifications of the Navigation characteristic.
  7. The IUT writes the Navigation Control Op Code (0x03) to the LN Control Point with a Parameter Value set to 0x04 (Skip Waypoint).
  8. The Lower Tester sends an indication of the LN Control Point characteristic with the Response Code Op Code (0x20) and a Parameter representing Request Op Code (0x03) followed by the Response Code for 'success' (0x01).
  9. The IUT sends ATT\_Handle\_Value\_Confirmation to the Lower Tester.
  10. The IUT continues receiving notifications of the Navigation characteristic.
  11. The IUT writes the Navigation Control Op Code (0x03) to the LN Control Point with a Parameter Value set to 0x00 (Stop).
  12. The Lower Tester sends an indication of the LN Control Point characteristic with the Response Code Op Code (0x20) and a Parameter representing Request Op Code (0x03) followed by the Response Code for 'success' (0x01).
  13. The IUT sends ATT\_Handle\_Value\_Confirmation to the Lower Tester.
- Expected Outcome

#### Pass verdict

When the IUT starts the navigation and the notifications of the Navigation characteristic, it receives and processes these notifications as expected.

When the IUT skips the waypoint, the notifications are not affected, and it receives and processes these notifications as expected.

When the IUT stops the navigation and the notifications of the Navigation characteristic, it stops receiving notifications.

The IUT receives the Request Op Code 'success' when it performs control procedures.

### [LNP/COL/SPN/BV-08-C \[Navigation Control – Select Nearest Waypoint on a Route\]](#)

- Test Purpose
 

Verify that the Collector IUT supports the Navigation feature.
- Reference
 

[\[3\] 4.7.2.3](#)
- Initial Condition
  - Perform the preamble described in Section [4.2.3](#).



- Test Procedure
  1. A connection is established between the IUT and Lower Tester using the Preamble defined in Section 4.2.4, if using an LE transport, or Section 4.2.5 if using a BR/EDR transport.
  2. The IUT has executed the procedure included in LNP/COL/SPN/BV-03-C [Select Route] to select route for Navigation.
  3. The IUT writes the Navigation Control Op Code (0x03) to the Navigation Control Point with a Parameter Value set to 0x05 (Select Nearest Waypoint on a Route).
  4. The Lower Tester sends an indication of the LN Control Point characteristic with the Response Code Op Code (0x20) and a Parameter representing Request Op Code (0x03) followed by the Response Code for 'success' (0x01).
  5. The IUT sends ATT\_Handle\_Value\_Confirmation to the Lower Tester.
  6. The IUT receives one or more notifications of the Navigation characteristic.
  7. The IUT writes the Navigation Control Op Code (0x03) to the LN Control Point with a Parameter Value set to 0x00 (Stop).
  8. The Lower Tester sends an indication of the LN Control Point characteristic with the Response Code Op Code (0x20) and a Parameter representing Request Op Code (0x03) followed by the Response Code for 'success' (0x01).
  9. The IUT sends ATT\_Handle\_Value\_Confirmation to the Lower Tester.

- Expected Outcome

#### Pass verdict

When the IUT select nearest waypoint on a route and starts the notifications of the Navigation characteristic, it receives and processes these notifications as expected.

When the IUT stops the navigation and the notifications of the Navigation characteristic, it stops receiving notifications.

The IUT receives the Request Op Code 'success' when it performs control procedures.

### 4.8.1 Service Procedure – Set Fix Rate

#### LNP/COL/SPF/BV-01-C [Set Fix Rate]

- Test Purpose
 

Verify that the Collector IUT can perform the Set Fix Rate procedure.
- Reference
 

[3] 4.7.2.7
- Initial Condition
  - Perform the preamble described in Section 4.2.3.
- Test Procedure
  1. A connection is established between the IUT and Lower Tester using the Preamble defined in Section 4.2.4, if using an LE transport, or Section 4.2.5 if using a BR/EDR transport.
  2. The IUT writes the Set Fix Rate Op Code (0x07) to the LN Control Point with a parameter value set to valid fix rate (UINT8).
  3. The Lower Tester sends an indication of the LN Control Point characteristic with the Response Code Op Code (0x20) and a Parameter representing the Request Op Code (0x07), the Response Code for 'success' (0x01) without response parameter.
  4. The IUT sends ATT\_Handle\_Value\_Confirmation to the Lower Tester.



- Expected Outcome

Pass verdict

The IUT receives the Request Op Code 'success'

## 4.9 Service Procedure – Set Elevation

### LNP/COL/SPA/BV-01-C [Set Elevation]

- Test Purpose

Verify that the Collector IUT can perform the Set Elevation procedure.

- Reference

[3] 4.7.2.8

- Initial Condition

- Perform the preamble described in Section 4.2.3.

- Test Procedure

1. A connection is established between the IUT and Lower Tester using the Preamble defined in Section 4.2.4, if using an LE transport, or Section 4.2.5 if using a BR/EDR transport.
2. The Lower Tester sends one or more notifications of the Location and Speed characteristic with the known Elevation value.
3. The IUT writes the Set Elevation Op Code (0x08) to the LN Control Point with a parameter value set to valid elevation value (SINT24) different from the known elevation value.
4. The Lower Tester sends an indication of the LN Control Point characteristic with the Response Code Op Code (0x20) and a Parameter representing the Request Op Code (0x08), the Response Code for 'success' (0x01) without response parameter.
5. The IUT sends ATT\_Handle\_Value\_Confirmation to the Lower Tester.
6. The Lower Tester sends a notification of the Location and Speed characteristic with the Elevation field set to new value as in step 3.

- Expected Outcome

Pass verdict

The IUT receives one or more notifications of the Location and Speed characteristic with the Elevation field set to the known value.

After setting the value, the IUT receives the next notification of the Location and Speed characteristic containing the Elevation field with the value of the Elevation field set to the new value as in step 3.

## 4.10 Service Procedures – General Error Handling

Verify compliant operation when an error is caused by the Server side.

### LNP/COL/SPE/BI-01-C [Unsupported Op Code]

- Test Purpose

Verify that the Collector IUT behaves appropriately when it receives an 'Op Code not supported' LN Control Point Response Code.



- Reference

[3] 4.7.3

- Initial Condition

- Perform the preamble described in Section 4.2.3.

- Test Procedure

1. A connection is established between the IUT and Lower Tester using the Preamble defined in Section 4.2.4, if using an LE transport, or Section 4.2.5 if using a BR/EDR transport.
2. The IUT writes any Op Code to the LN Control Point using an appropriate Parameter for the Op Code.
3. The Lower Tester sends an indication of the LN Control Point characteristic with the Response Code Op Code (0x20) and a Parameter representing Request Op Code followed by the Response Code Value for 'Op Code not supported' (0x02) (i.e., the Lower Tester simulates an unsupported Op Code).
4. The IUT sends ATT\_Handle\_Value\_Confirmation to the Lower Tester.
5. The IUT considers the procedure to have failed.

- Expected Outcome

Pass verdict

The IUT returns to stable state and can process commands normally.

- Notes

The test purpose is to verify the IUT's capability to handle an Op Code not supported response by the Sensor. This Sensor response may be provoked by the IUT writing an Op Code that is not supported by the responding compliant Sensor, or where the Sensor response to the IUT may be yielded by a test system that emulates that it does not support an Op Code.

### LNP/COL/SPE/BI-02-C [Invalid Parameter]

- Test Purpose

Verify that the Collector IUT behaves appropriately when it receives an 'Invalid Parameter' LN Control Point Response Code.

- Reference

[3] 4.7.3

- Initial Condition

- Perform the preamble described in Section 4.2.3.

- Test Procedure

1. A connection is established between the IUT and Lower Tester using the Preamble defined in Section 4.2.4, if using an LE transport, or Section 4.2.5 if using a BR/EDR transport.
2. The IUT writes the Update Sensor Location Op Code to the LN Control Point using any Sensor Location value.
3. The Lower Tester sends an indication of the LN Control Point characteristic with the Response Code Op Code (0x20) and a Parameter representing Request Op Code (0x02) followed by the Response Code Value for 'Invalid Parameter' (0x03) (i.e., the Lower Tester simulates an unsupported value).
4. The IUT sends ATT\_Handle\_Value\_Confirmation to the Lower Tester.



- Expected Outcome

Pass verdict

The IUT returns to stable state and can process commands normally.

### LNP/COL/SPE/BI-03-C [Operation Failed]

- Test Purpose

Verify that the Collector IUT behaves appropriately when it receives an 'Operation Failed' LN Control Point Response Code.

- Reference

[3] 4.7.3

- Initial Condition

- Perform the preamble described in Section 4.2.3.

- Test Procedure

1. A connection is established between the IUT and Lower Tester using the Preamble defined in Section 4.2.4, if using an LE transport, or Section 4.2.5 if using a BR/EDR transport.
2. The IUT writes any Op Code to the LN Control Point using an appropriate Parameter for the Op Code.
3. The Lower Tester sends an indication of the LN Control Point characteristic with the Response Code Op Code (0x20) and a Parameter representing Request Op Code followed by the Response Code Value for 'Operation Failed' (0x04) (i.e., the Lower Tester simulates a failed operation).
4. The IUT sends ATT\_Handle\_Value\_Confirmation to the Lower Tester.

- Expected Outcome

Pass verdict

The IUT returns to stable state and can process commands normally.

### LNP/COL/SPE/BI-04-C [LN Control Point Procedure Timeout]

- Test Purpose

Verify that if the Collector IUT does not receive a response to an LN Control Point Op Code, it times out after the Attribute Transaction Timeout.

- Reference

[3] 4.7.4

- Initial Condition

- Perform the preamble described in Section 4.2.3.

- Test Procedure

1. A connection is established between the IUT and Lower Tester using the Preamble defined in Section 4.2.4, if using an LE transport, or Section 4.2.5 if using a BR/EDR transport.
2. The IUT writes any of the supported Op Codes to the LN Control Point using an appropriate Parameter for the Op Code.

3. The Lower Tester does not send an indication of the LN Control Point characteristic for at least longer than the Attribute Protocol Timeout.
4. After the specified timeout the IUT sends a notification of Attribute Transaction Timeout to the Upper Tester and the IUT considers the procedure to have failed.

- Expected Outcome

Pass verdict

The IUT returns to a stable state and can process commands normally.

## 5 Test case mapping

The Test Case Mapping Table (TCMT) maps test cases to specific requirements in the ICS. The IUT is tested in all roles for which support is declared in the ICS document.

The columns for the TCMT are defined as follows:

**Item:** Contains a logical expression based on specific entries from the associated ICS document. Contains a logical expression (using the operators AND, OR, NOT as needed) based on specific entries from the applicable ICS document(s). The entries are in the form of y/x references, where y corresponds to the table number and x corresponds to the feature number as defined in the ICS document for the Location and Navigation Profile [4].

If a test case is mandatory within the respective layer, then the y/x reference is omitted.

**Feature:** A brief, informal description of the feature being tested.

**Test Case(s):** The applicable test case identifiers are required for Bluetooth Qualification if the corresponding y/x references defined in the Item column are supported. Further details about the function of the TCMT are elaborated in [1].

For the purpose and structure of the ICS/IXIT, refer to [1].

Item	Feature	Test Case(s)
LNP 7/1	Discover Location and Navigation Service	LNP/COL/CGGIT/SER/BV-01-C
LNP 8/1	Discover Device Information Service and characteristics	LNP/COL/CGGIT/SER/BV-02-C LNP/COL/LND/BV-14-C LNP/COL/LND/BV-15-C
LNP 9/1	Discover Battery Service and characteristics	LNP/COL/CGGIT/SER/BV-03-C LNP/COL/CGGIT/CHA/BV-06-C
(LNP 2/2 AND NOT LNP 2/1) AND GATT 1a/4	Discover Location and Navigation Service not discoverable - BR/EDR	LNP/SEN/SGGIT/SDPNF/BV-01-C
LNP 7/2	Discover LN Feature Characteristic	LNP/COL/CGGIT/CHA/BV-01-C
LNP 11a/1	Characteristic GGIT – LN Feature indication	LNP/COL/CGGIT/ISFC/BV-01-C
LNP 11a/2 AND (LNP 13/6 OR LNP 13/7)	Read LN Feature characteristic – Bonding enabled	LNP/COL/LNF/BV-14-C
(LNP 11a/1 OR LNP 11a/2) AND (LNP 13/6 OR LNP 13/7)	Enable LN Feature characteristic for indication or read characteristic upon reconnection	LNP/COL/LNF/BV-15-C
LNP 7/3	Discover Location and Speed Characteristic	LNP/COL/CGGIT/CHA/BV-02-C
LNP 7/5	Discover Position Quality Characteristic	LNP/COL/CGGIT/CHA/BV-03-C
LNP 7/6	Discover LN Control Point Characteristic	LNP/COL/CGGIT/CHA/BV-05-C
LNP 7/8	Discover Navigation Characteristic	LNP/COL/CGGIT/CHA/BV-04-C
LNP 3/2	Location and Navigation Service UUID in AD in GAP Discoverable Mode	LNP/SEN/LNF/BV-01-C

Item	Feature	Test Case(s)
LNP 3/3	Local Name in AD or Scan Response	LNP/SEN/LNF/BV-02-C
LNP 3/4	Appearance in AD or Scan Response	LNP/SEN/LNF/BV-03-C
LNP 11/1	Read LN Feature characteristic	LNP/COL/LNF/BI-01-C
LNP 11/2	Configure Location and Speed characteristic for Notification	LNP/COL/LNF/BV-05-C
LNP 11/3	Receive Location and Speed characteristic Notifications	LNP/COL/LNF/BV-06-C LNP/COL/LNF/BI-02-C LNP/COL/LNF/BI-03-C
LNP 10/19	Calculates or Displays Total Distance	LNP/COL/LNF/BV-07-C
LNP 10/20	Calculates or Displays Rolling Time	LNP/COL/LNF/BV-08-C
LNP 11/6	Read Position Quality characteristic	LNP/COL/LNF/BV-09-C LNP/COL/LNF/BI-04-C
LNP 11/4	Configure Navigation characteristic for Notification	LNP/COL/LNF/BV-10-C
LNP 11/5	Receive Navigation characteristic Notifications	LNP/COL/LNF/BV-11-C LNP/COL/LNF/BI-05-C
LNP 2/2 AND LNP 11/19	Verify Bond Status on Reconnection - LE	LNP/COL/LNF/BV-12-C
LNP 2/1 AND LNP 11/19	Verify Bond Status on Reconnection - BR/EDR	LNP/COL/LNF/BV-13-C
LNP 10/21	Set Cumulative Value – Set to zero	LNP/COL/SPS/BV-01-C
LNP 10/22	Set Cumulative Value – Set to non-zero	LNP/COL/SPS/BV-02-C
LNP 10/23	Mask Location and Speed Characteristic Content	LNP/COL/SPM/BV-01-C
LNP 10/24	Navigation Control	LNP/COL/SPN/BV-04-C LNP/COL/SPN/BV-05-C LNP/COL/SPN/BV-06-C LNP/COL/SPN/BV-07-C LNP/COL/SPN/BV-08-C
LNP 10/25	Request Number of Routes	LNP/COL/SPN/BV-01-C
LNP 10/26	Request Name of Route	LNP/COL/SPN/BV-02-C
LNP 10/27	Select Route	LNP/COL/SPN/BV-03-C
LNP 10/28	Set Fix Rate	LNP/COL/SPF/BV-01-C
LNP 10/29	Set Elevation	LNP/COL/SPA/BV-01-C
LNP 11/7 AND LNP 11/8	Write to LN Control Point characteristic and Receive LN Control Point characteristic indications	LNP/COL/SPE/BI-01-C LNP/COL/SPE/BI-02-C LNP/COL/SPE/BI-03-C
LNP 11/18	LN Control Point - Procedure Timeout	LNP/COL/SPE/BI-04-C

Table 5.1: Test case mapping

## 6 Revision history and acknowledgments

### Revision History

Publication Number	Revision Number	Date	Comments
0	1.0.0	2013-04-30	Release for publication.
	1.0.1r01	2013-09-30	TSE 5296: Updated first sentence of test procedure in LNP/COL/LND/BV-15-I (legacy ID: TP/LND/CO/BV-15-I) to add, "and a disconnection may occur between the two tests" for clarification.
1	1.0.1	2013-12-03	Prepare for Publication
	1.0.2r00	2014-04-11	TSE 5452: Updated TCMT Mapping for LNP/COL/LND/BV-01-I (legacy ID: TP/LND/CO/BV-01-I).
	1.0.2r01	2014-06-01	Added Pass/Fail Verdict Conventions according to applicable test specification template.
2	1.0.2	2014-07-07	TCRL 2014-1 Publication
	1.0.3r00	2016-05-25	Converted to new Test Case ID conventions as defined in TSTO v4.1.
3	1.0.3	2016-07-14	Prepared for TCRL 2016-1 publication.
	1.0.4r00	2017-10-02	TSE 9916 (rating 1): Update test specification template and conventions.
4	1.0.4	2018-06-27	Approved by BTI. Prepared for TCRL 2018-1 publication.
	p5r00–r03	2022-03-17 – 2022-05-18	<p>TSE 17263 (rating 2): Converted the following test cases to GGIT: LNP/COL/LNF/BV-04-I, LNP/SEN/LND/BV-05-I, and LNP/COL/LND/BV-01-I – -04-I, -06-I – -13-I, -16-I, and -17-I. The new GGIT converted TCIDs are: LNP/COL/CGGIT/CHA/BV-01-C – -06-C, LNP/COL/CGGIT/SER/BV-01-C – -03-C, and LNP/SEN/SGGIT/SDPNF/BV-01-C. Updated the TCMT accordingly. Updated the initial condition for LNP/COL/LND/BV-14-I. Inserted a test database requirements section. Updated test groups and test case identification conventions section.</p> <p>TSE 18427 (rating 1): Removed direct references to GATT test cases from the test procedures for LNP/COL/LND/BV-14-I and -15-I. Removed direct references to GATT TS sections from the ATT Bearer preambles and replaced with preamble procedure text.</p> <p>TSE 18720 (rating 1): Editorials to align the document with the latest TS template in anticipation of a future .Z release.</p> <p>Editorials, including assigning publication number 4 to previous v1.0.4, consistency checker fixes, and aligning the copyright page with v2 of the DNMD.</p>
5	p5	2022-06-28	Approved by BTI on 2022-05-31. Prepared for TCRL 2022-1 publication.
	p6r00	2022-08-18	TSE 19015 (rating 2): Corrected the value length for GGIT test LNP/COL/CGGIT/CHA/BV-05-C.

Publication Number	Revision Number	Date	Comments
6	p6	2023-02-07	Approved by BTI on 2022-12-28. Prepared for TCRL 2022-2 publication.
	p7r00	2023-10-31	TSE 23277 (rating 1): Converted -I tests to -C tests as appropriate; updated the TCMT and TCRL accordingly.
7	p7	2024-07-01	Approved by BTI on 2024-04-21. Prepared for TCRL 2024-1 publication.
	p8r00–r02	2024-08-05 – 2024-08-21	TSE 17241 (rating 4): Per E17188, added reference to Location and Navigation Profile Specification, Version 1.0.1, added new test group ISFC and new TCs LNP/COL/CGGIT/ISFC/BV-01-C, LNP/COL/LNF/BV-14-C and -15-C. Updated LNP/COL/CGGIT/CHA/BV-01-C property value. Updated TCMT accordingly. TSE 18591 (rating 1): Per E15799, added appropriate language updates for the Bonded Devices section and TC LNP/COL/LNF/BV-13-C.
8	p8	2024-10-08	Approved by BTI on 2024-09-11. LNP v1.0.1 adopted by the BoD on 2024-10-01. Prepared for TCRL 2024-2-addition publication.
	p9r00	2025-07-18	TSE 27520 (rating 2): Removed reference to GAP 0/3 in the TCMT entry for LNP/SEN/SGGIT/SDPNF/BV-01-C.
9	p9	2025-11-04	Approved by BTI on 2025-10-02. Prepared for TCRL pkg101 publication.

### Acknowledgments

Name	Company
Dejan Berec	Bluetooth SIG, Inc.
Jawid Mirani	Bluetooth SIG, Inc.
Bob Hughes	Intel
Guillaume Schatz	Polar
Olli-Pekka Ojanen	Suunto
Ewa Pulkkinen	Suunto