

Logical Link Control and Adaptation Protocol (L2CAP)

Bluetooth® Test Suite

- **Revision:** L2CAP.TS.p42
- **Revision Date:** 2026-05-05
- **Prepared By:** BTI
- **Published during TCRL:** TCRL.pkg103



This document, regardless of its title or content, is not a Bluetooth Specification as defined in the Bluetooth Patent/Copyright License Agreement (“PCLA”) and Bluetooth Trademark License Agreement. Use of this document by members of Bluetooth SIG is governed by the membership and other related agreements between Bluetooth SIG Inc. (“Bluetooth SIG”) and its members, including the PCLA and other agreements posted on Bluetooth SIG’s website located at www.bluetooth.com.

THIS DOCUMENT IS PROVIDED “AS IS” AND BLUETOOTH SIG, ITS MEMBERS, AND THEIR AFFILIATES MAKE NO REPRESENTATIONS OR WARRANTIES AND DISCLAIM ALL WARRANTIES, EXPRESS OR IMPLIED, INCLUDING ANY WARRANTY OF MERCHANTABILITY, TITLE, NON-INFRINGEMENT, FITNESS FOR ANY PARTICULAR PURPOSE, THAT THE CONTENT OF THIS DOCUMENT IS FREE OF ERRORS.

TO THE EXTENT NOT PROHIBITED BY LAW, BLUETOOTH SIG, ITS MEMBERS, AND THEIR AFFILIATES DISCLAIM ALL LIABILITY ARISING OUT OF OR RELATING TO USE OF THIS DOCUMENT AND ANY INFORMATION CONTAINED IN THIS DOCUMENT, INCLUDING LOST REVENUE, PROFITS, DATA OR PROGRAMS, OR BUSINESS INTERRUPTION, OR FOR SPECIAL, INDIRECT, CONSEQUENTIAL, INCIDENTAL OR PUNITIVE DAMAGES, HOWEVER CAUSED AND REGARDLESS OF THE THEORY OF LIABILITY, AND EVEN IF BLUETOOTH SIG, ITS MEMBERS, OR THEIR AFFILIATES HAVE BEEN ADVISED OF THE POSSIBILITY OF SUCH DAMAGES.

This document is proprietary to Bluetooth SIG. This document may contain or cover subject matter that is intellectual property of Bluetooth SIG and its members. The furnishing of this document does not grant any license to any intellectual property of Bluetooth SIG or its members.

This document is subject to change without notice.

Copyright © 2003–2026 by Bluetooth SIG, Inc. The Bluetooth word mark and logos are owned by Bluetooth SIG, Inc. Other third-party brands and names are the property of their respective owners.



Contents

1	Scope	12
2	References, definitions, and abbreviations	13
2.1	References.....	13
2.2	Definitions	13
2.3	Acronyms and abbreviations	13
3	Test Suite Structure (TSS)	14
3.1	Test Strategy.....	14
3.2	Test groups	14
3.2.1	Protocol service groups	14
3.2.2	Main test groups	16
3.2.3	Behavior testing groups	16
4	Test cases (TC)	17
4.1	Introduction	17
4.1.1	Test case identification conventions	17
4.1.2	MSC abbreviations.....	18
4.1.3	Conformance	18
4.1.4	Lower layer assumptions	19
4.1.5	Upper Tester.....	19
4.1.6	General information about MSC	19
4.1.7	Pass/Fail verdict conventions	19
4.2	Preamble IXITs	19
4.3	Common Packet Contents.....	20
4.3.1	Fields and Bits Reserved for Future Use	20
4.4	Connection-Oriented Basic L2CAP mode	20
4.4.1	Basic Operation Data Channel CED	20
	L2CAP/COS/CED/BV-01-C [Request Connection]	20
	L2CAP/COS/CED/BV-03-C [Send Data].....	21
	L2CAP/COS/CED/BV-04-C [Disconnect].....	22
	L2CAP/COS/CED/BV-07-C [Accept Disconnect].....	23
	L2CAP/COS/CED/BV-08-C [Disconnect on Timeout].....	23
	L2CAP/COS/CED/BV-09-C [Receive Multi-Command Packet].....	25
	L2CAP/COS/CED/BV-10-C [Transmit I-frames].....	26
	L2CAP/COS/CED/BV-11-C [Configure MTU Size]	27
	L2CAP/COS/CED/BV-12-C [Recombination of Signaling Packets]	27
	L2CAP/COS/CED/BI-03-C [Incorrect PDU Length, Received Data Packet, Basic].....	28
	L2CAP/COS/CED/BI-30-C [Accept Reject of Connection Request, Peer Older Than v4.2]	29
	L2CAP/COS/CED/BI-04-C [Incorrect PDU Length, C-Frame, BR/EDR]	31
	L2CAP/COS/CED/BI-05-C [Incorrect PDU Length, C-Frame, LE Credit Based Connection Request]	31
	L2CAP/COS/CED/BI-18-C [Incorrect PDU Length, C-Frame, LE Enhanced Credit Based Connection Request].....	31
	L2CAP/COS/CED/BI-19-C [Incorrect PDU Length, C-Frame, LE Credit Based Connection Request Rejected].....	31
	L2CAP/COS/CED/BI-06-C [Incorrect PDU Length, Received Data Packets with Continuation, Basic]	32
	L2CAP/COS/CED/BI-07-C [Incorrect PDU Length, Received Data Packets with Multiple Continuation]	33
	L2CAP/COS/CED/BI-08-C [Valid Signaling Command, Data Length > PDU Space, BR/EDR]	34
	L2CAP/COS/CED/BI-09-C [Valid Signaling Command, Data Length > PDU Space, LE Credit Based Connection Request]	34



L2CAP/COS/CED/BI-20-C [Valid Signaling Command, Data Length > PDU Space, LE Enhanced Credit Based Connection Request]	35
L2CAP/COS/CED/BI-21-C [Valid Signaling Command, Data Length > PDU Space, LE Credit Based Connection Request Rejected]	35
L2CAP/COS/CED/BI-10-C [Incorrect Signaling Command Packets, Invalid Data Length for Command, BR/EDR]	36
L2CAP/COS/CED/BI-11-C [Incorrect Signaling Command Packets, Invalid Data Length for Command, LE]	36
L2CAP/COS/CED/BI-12-C [Valid Signaling Command, Shorter Data Length, Extra Zero Octet, BR/EDR]	37
L2CAP/COS/CED/BI-13-C [Valid Signaling Command, Shorter Data Length, Extra Zero Octet, LE Credit Based Connection Request]	39
L2CAP/COS/CED/BI-22-C [Valid Signaling Command, Shorter Data Length, Extra Zero Octet, LE Enhanced Credit Based Connection Request]	39
L2CAP/COS/CED/BI-23-C [Valid Signaling Command, Shorter Data Length, Extra Zero Octet, LE Enhanced Credit Based Connection Request Rejected]	39
L2CAP/COS/CED/BI-14-C [Multiple Signaling Command in one PDU, Data Truncated, BR/EDR, Echo Request]	41
L2CAP/COS/CED/BI-15-C [Multiple Signaling Command in one PDU, Data Truncated, BR/EDR, Disconnection Request]	41
L2CAP/COS/CED/BI-16-C [Multiple Signaling Command in one PDU, Data Truncated, LE Credit Based Flow Control Mode, LE Credit Based Connection Request]	43
L2CAP/COS/CED/BI-17-C [Multiple Signaling Command in one PDU, Data Truncated, LE Credit Based Flow Control Mode, Disconnection Request]	43
L2CAP/COS/CED/BI-24-C [Multiple Signaling Command in one PDU, LE, Data Truncated, Enhanced Credit Based Flow Control Mode, Enhanced Credit Based Connection Request]	43
L2CAP/COS/CED/BI-25-C [Multiple Signaling Command in one PDU, LE, Data Truncated, Enhanced Credit Based Flow Control Mode, Disconnection Request]	43
L2CAP/COS/CED/BI-28-C [Ignore Command Response with Invalid ID or Duplicate Response, BR/EDR]	45
L2CAP/COS/CED/BI-29-C [Ignore Command Response with Invalid ID or Duplicate Response, LE]	45
4.4.2 Encryption Key Size	47
4.4.3 Configuration of Data Channel CFD	47
L2CAP/COS/CFD/BV-01-C [Continuation Flag]	47
L2CAP/COS/CFD/BV-02-C [Negotiation with Reject]	49
L2CAP/COS/CFD/BV-03-C [Send Requested Options]	50
L2CAP/COS/CFD/BV-08-C [Non-blocking Config Response]	50
L2CAP/COS/CFD/BV-09-C [Mandatory 48 Byte MTU]	51
L2CAP/COS/CFD/BV-10-C [Retransmission Mode Negotiation]	53
L2CAP/COS/CFD/BV-11-C [Negotiation of Unsupported Parameter]	53
L2CAP/COS/CFD/BV-12-C [Unknown Option Response]	54
L2CAP/COS/CFD/BV-13-C [Flow Control Mode Negotiation]	55
L2CAP/COS/CFD/BV-14-C [Unknown Mandatory Options Request]	56
4.4.4 Implementation-Specific Information Exchange IEX	57
L2CAP/COS/IEX/BV-01-C [Query for 1.2 Features]	57
L2CAP/COS/IEX/BV-02-C [Respond with 1.2 Features]	58
L2CAP/COS/IEX/BI-01-C [Accept Reject of Information Request, Peer Older Than v3.0]	59
4.4.5 Echo Handling ECH	60
L2CAP/COS/ECH/BV-01-C [Respond to Echo Request]	60
L2CAP/COS/ECH/BV-02-C [Send Echo Request]	60
4.4.6 LE Credit Based Flow Control Mode	61
L2CAP/COS/CFC/BV-01-C [Segmentation]	61
L2CAP/COS/CFC/BV-02-C [No Segmentation]	62
L2CAP/COS/CFC/BV-03-C [Reassembling]	63
L2CAP/COS/CFC/BV-04-C [Data Receiving]	64
L2CAP/COS/CFC/BV-05-C [Multiple Channels with Interleaved Data Streams]	65
L2CAP/LE/CFC/BV-30-C [Recombination of Signaling Packets]	68



L2CAP/ECFC/BV-39-C [Recombination of Signaling Packets - LE] 68

L2CAP/ECFC/BV-40-C [Recombination of Signaling Packets – BR/EDR] 68

L2CAP/LE/CFC/BV-31-C [Recombination of Data Packets] 70

L2CAP/ECFC/BV-41-C [Recombination of Data Packets] 70

L2CAP/ECFC/BV-42-C [Recombination of Data Packets] 70

L2CAP/ECFC/BI-09-C [Incorrect Size Signaling Packets, BR/EDR] 71

4.4.7 Enhanced Credit Based Flow Control Mode 73

L2CAP/COS/ECFC/BV-01-C [Segmentation, LE] 73

L2CAP/COS/ECFC/BV-05-C [Segmentation, BR/EDR] 73

L2CAP/COS/ECFC/BV-02-C [Reassembling, LE] 74

L2CAP/COS/ECFC/BV-06-C [Reassembling, BR/EDR] 74

L2CAP/COS/ECFC/BV-03-C [Multiple Channels with Interleaved Data Streams, LE] 75

L2CAP/COS/ECFC/BV-07-C [Multiple Channels with Interleaved Data Streams, BR/EDR] 75

L2CAP/COS/ECFC/BV-04-C [Reassembling, LE] 76

L2CAP/COS/ECFC/BV-08-C [Reassembling, BR/EDR] 76

4.5 Connection-Oriented Retransmission/Flow Control/Streaming modes 77

4.5.1 Flow Control 77

L2CAP/COS/FLC/BV-01-C [Flow Control without Acks] 77

L2CAP/COS/FLC/BV-02-C [Resume Flow on RR Frame Ack] 78

L2CAP/COS/FLC/BV-03-C [Resume Flow on I-frame Ack] 79

L2CAP/COS/FLC/BV-04-C [Transmit RR Frame on Monitor Timeout] 80

4.5.2 Retransmission 80

L2CAP/COS/RTX/BV-01-C [No Retransmission with R=1] 80

L2CAP/COS/RTX/BV-02-C [Retransmission with R=0 in RR frame] 81

L2CAP/COS/RTX/BV-03-C [Retransmission with R=0 in I-frame] 82

4.5.3 Extended Features (EXF) 83

L2CAP/EXF/BV-07-C [Extended Features Information Response] 83

L2CAP/EXF/BV-08-C [Information Request, Extended Features] 84

4.5.4 Channel Mode Configuration (CMC) 85

L2CAP/CMC/BV-01-C [IUT Initiated Configuration of Enhanced Retransmission Mode] 85

L2CAP/CMC/BV-02-C [Lower Tester Initiated Configuration of Enhanced Retransmission Mode] 86

L2CAP/CMC/BV-03-C [Failed Configuration of Enhanced Retransmission Mode when use of the Mode is Optional] 87

L2CAP/CMC/BV-04-C [IUT Initiated Configuration of Streaming Mode] 88

L2CAP/CMC/BV-05-C [Lower Tester Initiated Configuration of Streaming Mode] 89

L2CAP/CMC/BV-06-C [Failed Configuration of Streaming Mode when use of the Mode is Optional] 90

L2CAP/CMC/BV-07-C [Configuration Mode mismatch when use of Enhanced Retransmission Mode is Optional] 91

L2CAP/CMC/BV-08-C [Configuration Mode Mismatch when use of Streaming Mode is Optional] 92

L2CAP/CMC/BV-09-C [Configuration to Basic Mode by the IUT] 93

L2CAP/CMC/BI-01-C [Failed Configuration of Enhanced Retransmission Mode when use of the Mode is Mandatory] 95

L2CAP/CMC/BI-02-C [Configuration Mode mismatch when use of Enhanced Retransmission Mode is Mandatory] 96

L2CAP/CMC/BI-03-C [Failed Configuration of Streaming Mode when use of the Mode is Mandatory] 96

L2CAP/CMC/BI-04-C [Configuration Mode mismatch when use of Streaming Mode is Mandatory] 97

L2CAP/CMC/BI-05-C [Failed Configuration to Basic Mode by the IUT] 98

L2CAP/CMC/BI-06-C [Configuration to Basic Mode Rejected by the Lower Tester] 99

L2CAP/CMC/BV-10-C [ERTM Not Supported by Lower Tester for Optional ERTM Channel] 100

L2CAP/CMC/BV-11-C [Streaming Mode not supported by Lower Tester for Optional Streaming Mode Channel] 101

L2CAP/CMC/BV-12-C [ERTM Not Supported by Lower Tester for Mandatory ERTM channel] 102

L2CAP/CMC/BV-13-C [Streaming Mode not supported by Lower Tester for Mandatory Streaming Mode Channel] 103

L2CAP/CMC/BV-14-C [Failed Configuration of Streaming Mode when use of the mode is optional and ERTM is proposed by the Lower Tester] 104



L2CAP/CMC/BV-15-C [Configuration Mode Mismatch when use of Streaming Mode is Optional and ERTM is proposed by the Lower Tester]..... 105

4.5.5 Frame Check Sequence (FCS) Option Configuration (FOC) 107

L2CAP/FOC/BV-01-C [IUT Initiated Configuration of the FCS Option, IUT No FCS Option, Lower Tester No FCS Option]..... 107

L2CAP/FOC/BV-02-C [IUT Initiated Configuration of the FCS Option, IUT No FCS Option, Lower Tester Yes FCS Option] 107

L2CAP/FOC/BV-03-C [IUT Initiated Configuration of the FCS Option, IUT No FCS Option, Lower Tester Omitted FCS Option]..... 107

L2CAP/FOC/BV-04-C [IUT Initiated Configuration of the FCS Option, IUT FCS 0x01]..... 109

L2CAP/FOC/BV-06-C [IUT Initiated Configuration of the FCS Option, IUT FCS Omitted]..... 109

L2CAP/FOC/BV-05-C [IUT Responder, Configuration of the FCS Option, IUT FCS 0x00]..... 111

L2CAP/FOC/BV-07-C [IUT Responder, Configuration of the FCS Option, IUT FCS 0x01]..... 111

L2CAP/FOC/BV-08-C [IUT Responder, Configuration of the FCS Option, IUT FCS Omitted] 111

4.5.6 Optional FCS (OFS)..... 113

L2CAP/OFS/BV-01-C [Sending I-Frames without FCS for ERTM] 113

L2CAP/OFS/BV-02-C [Receiving Frames without FCS for ERTM] 113

L2CAP/OFS/BV-03-C [Sending I-Frames without FCS for Streaming Mode] 114

L2CAP/OFS/BV-04-C [Receiving Frames without FCS for Streaming Mode]..... 115

L2CAP/OFS/BV-05-C [Sending I-Frames with FCS for ERTM] 115

L2CAP/OFS/BV-06-C [Receiving Frames with FCS for ERTM] 116

L2CAP/OFS/BV-07-C [Sending I-Frames with FCS for Streaming Mode] 117

L2CAP/OFS/BV-08-C [Receiving Frames with FCS for Streaming Mode]..... 117

4.5.7 Enhanced Retransmission Mode (ERM)..... 118

L2CAP/ERM/BV-01-C [Transmit I-frames]..... 118

L2CAP/ERM/BV-02-C [Receive I-Frames]..... 119

L2CAP/ERM/BV-03-C [Acknowledging Received I-Frames]..... 121

L2CAP/ERM/BV-05-C [Resume Transmitting I-Frames when an S-Frame [RR] is Received]..... 121

L2CAP/ERM/BV-06-C [Resume Transmitting I-Frames when an I-Frame is Received] 122

L2CAP/ERM/BV-07-C [Send S-Frame [RNR]] 123

L2CAP/ERM/BV-08-C [Send S-Frame [RR] with Poll Bit Set]..... 124

L2CAP/ERM/BV-09-C [Send S-frame [RR] with Final Bit Set] 125

L2CAP/ERM/BV-10-C [Retransmit S-Frame [RR] with Poll Bit Set]..... 126

L2CAP/ERM/BV-11-C [S-Frame Transmissions Exceed MaxTransmit] 127

L2CAP/ERM/BV-12-C [I-Frame Transmissions Exceed MaxTransmit]..... 128

L2CAP/ERM/BV-13-C [Respond to S-Frame [REJ]] 129

L2CAP/ERM/BV-14-C [Respond to S-Frame [SREJ] POLL Bit Set] 130

L2CAP/ERM/BV-15-C [Respond to S-Frame [SREJ] POLL bit clear] 131

L2CAP/ERM/BV-16-C [Send S-Frame [REJ]] 132

L2CAP/ERM/BV-17-C [Send S-Frame [SREJ]]..... 133

L2CAP/ERM/BV-18-C [Receive S-Frame [RR] Final Bit = 1] 134

L2CAP/ERM/BV-19-C [Receive I-Frame Final Bit = 1]..... 135

L2CAP/ERM/BV-20-C [Enter Remote Busy Condition]..... 136

L2CAP/ERM/BV-22-C [Exit Local Busy Condition] 137

L2CAP/ERM/BV-23-C [Transmit I-Frames using SAR]..... 138

L2CAP/ERM/BI-01-C [S-Frame [REJ] Lost or Corrupted]..... 139

L2CAP/ERM/BI-02-C [S-Frame [SREJ] Lost or Corrupted]..... 140

L2CAP/ERM/BI-03-C [Handle Duplicate S-Frame [SREJ]] 141

L2CAP/ERM/BI-04-C [Handle Receipt of S-Frame [REJ] and S-Frame [RR, F=1] that Both Require Retransmission of the Same I-Frames]..... 142

L2CAP/ERM/BI-05-C [Handle receipt of S-Frame [REJ] and I-Frame [F=1] that Both Require Retransmission of the Same I-Frames]..... 143

4.5.8 Streaming Mode (STM)..... 144

L2CAP/STM/BV-01-C [Streaming Mode Source]..... 144

L2CAP/STM/BV-02-C [Streaming Mode Sink] 145

L2CAP/STM/BV-03-C [Streaming Mode Source using SAR] 146



4.5.9	Fixed Channel Support (FIX)	147
	L2CAP/FIX/BV-01-C [Fixed Channels Supported Information Request]	147
	L2CAP/FIX/BV-02-C [AMP Manager Channel Supported]	148
	L2CAP/FIX/BV-03-C [Information Request, Fixed Channels Supported]	149
4.5.10	Extended Window Size Configuration (EWC)	150
	L2CAP/EWC/BV-01-C [IUT Initiated Extended Window Size Option]	150
	L2CAP/EWC/BV-02-C [Lower Tester Requests Extended Window Size]	151
	L2CAP/EWC/BV-03-C [Extended Window Size Option Not Supported by Lower Tester]	152
4.5.11	Lock Step Configuration (LSC)	153
	L2CAP/LSC/BV-01-C [Normal Lock Step Configuration Process for Best Effort, BR/EDR ERTM Channel]	153
	L2CAP/LSC/BV-02-C [Normal Lock Step Configuration Process for Guaranteed, BR/EDR ERTM Channel]	154
	L2CAP/LSC/BV-03-C [Premature Success in Configuration Response, BR/EDR ERTM Channel]	156
	L2CAP/LSC/BI-04-C [Mismatched Service Type, Best Effort, BR/EDR ERTM Channel]	157
	L2CAP/LSC/BI-05-C [Mismatched Service Type, Guaranteed, BR/EDR ERTM Channel]	158
	L2CAP/LSC/BV-06-C [Remote Failed on Guaranteed, BR/EDR ERTM Channel]	159
	L2CAP/LSC/BV-07-C [Normal Lock Step Configuration Process for Best Effort, AMP Channel]	160
	L2CAP/LSC/BV-08-C [Normal Lock Step Configuration Process for Guaranteed, AMP Channel]	161
	L2CAP/LSC/BV-09-C [Premature Success in Configuration Response, AMP Channel]	162
	L2CAP/LSC/BI-10-C [Mismatched Service Type, Best Effort, AMP Channel]	163
	L2CAP/LSC/BI-11-C [Mismatched Service Type, Guaranteed, AMP Channel]	164
	L2CAP/LSC/BV-12-C [Remote Failed on Guaranteed, AMP Channel]	165
4.5.12	Create Channel (CCH)	166
	L2CAP/CCH/BV-01-C [Create Channel Request for an AMP Physical Link]	166
	L2CAP/CCH/BV-02-C [Create Channel Request for an AMP Physical Link – Refused]	167
	L2CAP/CCH/BV-03-C [Create Channel Request for an AMP Physical Link – Failed]	168
	L2CAP/CCH/BV-04-C [Create Channel Response for an AMP Physical Link]	169
4.5.13	Move Channel (MCH)	170
	L2CAP/MCH/BV-01-C [Move ERTM Channel Request for BR/EDR to AMP – Success]	170
	L2CAP/MCH/BV-02-C [Move ERTM Channel Request for BR/EDR to AMP – Refused]	172
	L2CAP/MCH/BV-03-C [Move ERTM Channel Request for BR/EDR to AMP – AMP Fail]	173
	L2CAP/MCH/BV-04-C [Move ERTM Channel Request for AMP to BR/EDR – Success]	174
	L2CAP/MCH/BV-05-C [Move ERTM Channel Request for AMP to BR/EDR – Refused]	176
	L2CAP/MCH/BV-06-C [Move ERTM Channel Response for BR/EDR to AMP – Success]	177
	L2CAP/MCH/BV-07-C [Move ERTM Channel Response for BR/EDR to AMP – Failure]	178
	L2CAP/MCH/BV-08-C [Move ERTM Channel Response for AMP to BR/EDR – Success]	179
	L2CAP/MCH/BV-09-C [Move ERTM Channel Response for AMP to BR/EDR – Failure]	180
	L2CAP/MCH/BV-10-C [Data Transfer while Moving ERTM Channel from BR/EDR to AMP]	182
	L2CAP/MCH/BV-11-C [Data Transfer while Moving ERTM Channel from BR/EDR to AMP – Unacknowledged Data]	183
	L2CAP/MCH/BV-12-C [Data Transfer while Moving ERTM Channel from AMP to BR/EDR]	184
	L2CAP/MCH/BV-13-C [Data Transfer while Moving ERTM Channel from AMP to BR/EDR – Unacknowledged Data]	186
	L2CAP/MCH/BV-14-C [Move Collision – ERTM]	188
	L2CAP/MCH/BV-15-C [Move Channel Request for BR/EDR to AMP (STM Source) – Success]	190
	L2CAP/MCH/BV-16-C [Move Channel Request for BR/EDR to AMP (STM Sink) – Success]	191
	L2CAP/MCH/BV-17-C [Move Channel Request for BR/EDR to AMP (STM Source) – Refused]	193
	L2CAP/MCH/BV-18-C [Move Channel Request for BR/EDR to AMP (STM Sink) – Refused]	194
	L2CAP/MCH/BV-19-C [Move Channel Request for BR/EDR to AMP (STM Source) – AMP Fail]	195
	L2CAP/MCH/BV-20-C [Move Channel Request for BR/EDR to AMP (STM Sink) – AMP Failed]	196
	L2CAP/MCH/BV-21-C [Move Channel Request for AMP to BR/EDR (STM Source) – Success]	198
	L2CAP/MCH/BV-22-C [Move Channel Request for AMP to BR/EDR (STM Sink) – Success]	199
	L2CAP/MCH/BV-23-C [Move Channel Request for AMP to BR/EDR (STM Source) – Refused]	200
	L2CAP/MCH/BV-24-C [Move Channel Request for AMP to BR/EDR (STM Sink) – Refused]	202
	L2CAP/MCH/BV-25-C [Move Channel Request for AMP to BR/EDR (STM Source) – AMP Fail]	203

L2CAP/MCH/BV-26-C [Move Channel Request for AMP to BR/EDR (STM Sink) – AMP Failed]..... 204

L2CAP/MCH/BV-27-C [Move Channel Response for BR/EDR to AMP (STM Source) – Success]..... 205

L2CAP/MCH/BV-28-C [Move Channel Response for BR/EDR to AMP (STM Sink) – Success]..... 207

L2CAP/MCH/BV-29-C [Move Channel Response for AMP to BR/EDR (STM Source) – Success]..... 208

L2CAP/MCH/BV-30-C [Move Channel Response for AMP to BR/EDR (STM Sink) – Success]..... 210

L2CAP/MCH/BV-31-C [Move Channel Response for BR/EDR to AMP (STM Source) – Failed] 211

L2CAP/MCH/BV-32-C [Move Channel Response for BR/EDR to AMP (STM Sink) – Failed]..... 212

L2CAP/MCH/BV-33-C [Move Channel Response for AMP to BR/EDR (STM Source) – Failed] 213

L2CAP/MCH/BV-34-C [Move Channel Response for AMP to BR/EDR (STM Sink) – Failed]..... 215

L2CAP/MCH/BV-35-C [Move Collision – STM Source]..... 217

L2CAP/MCH/BV-36-C [Move Collision – STM Sink]..... 219

4.5.14 Enhanced Retransmission Mode with Extended Control Field (ECF)..... 221

L2CAP/ECF/BV-01-C [Receive I-Frames with Extended Control Field] 221

L2CAP/ECF/BV-02-C [Transmit I-Frames with Extended Control Field]..... 223

L2CAP/ECF/BV-03-C [Acknowledging Received I-Frames with Extended Control Field]..... 224

L2CAP/ECF/BV-04-C [Send S-Frame [RR] with Extended Control Field and Poll Bit Set] 224

L2CAP/ECF/BV-05-C [Respond to S-Frame [REJ] with Extended Control Field] 225

L2CAP/ECF/BV-06-C [Respond to S-Frame [SREJ] with Extended Control Field and POLL bit Set]..... 226

L2CAP/ECF/BV-07-C [Respond to S-Frame [SREJ] with Extended Control Field and POLL Bit Clear] 227

L2CAP/ECF/BV-08-C [Transmit I-Frames using Extended Control Field and SAR] 228

4.5.15 Streaming Mode with Extended Control Field (STM)..... 230

L2CAP/STM/BV-11-C [Streaming Mode Source with Extended Control Field] 230

L2CAP/STM/BV-12-C [Streaming Mode Sink with Extended Control Field] 231

L2CAP/STM/BV-13-C [Streaming Mode Source using Extended Control Field and SAR]..... 231

4.6 Low Energy System tests 232

4.6.1 Connection Parameter Update 232

L2CAP/LE/CPU/BV-01-C [Send Connection Parameter Update Request] 232

L2CAP/LE/CPU/BV-02-C [Accept Connection Parameter Update Request] 233

L2CAP/LE/CPU/BI-01-C [Reject Connection Parameter Update Parameters] 234

L2CAP/LE/CPU/BI-02-C [Reject Connection Parameter Update Request]..... 235

4.6.2 Command Reject..... 236

L2CAP/COS/CED/BI-01-C [Reject Unknown Command, BR/EDR] 237

L2CAP/LE/REJ/BI-02-C [Reject Unknown Command – LE] 237

4.7 Connectionless Basic L2CAP Mode..... 238

4.7.1 Connectionless Reception Channel CLR..... 238

L2CAP/CLS/CLR/BV-01-C [Data Over Connectionless Channel]..... 238

L2CAP/CLS/UCD/BV-01-C [Data Reception over Unicast Connectionless Channel] 239

L2CAP/CLS/UCD/BV-02-C [Unencrypted data transmission over unicast connectionless channel]..... 239

L2CAP/CLS/UCD/BV-03-C [Encrypted Data Transmission over Unicast Connectionless Channel]..... 240

4.8 Channel Identifiers (CID) 241

L2CAP/LE/CID/BV-01-C [Receiving DCID over BR/EDR and LE] 241

L2CAP/LE/CID/BV-02-C [Receiving SCID over BR/EDR and LE] 242

L2CAP/LE/CID/BV-03-C [Receiving same DCID over BR/EDR and LE] 243

L2CAP/LE/CID/BV-04-C [Receiving same SCID over BR/EDR and LE]..... 244

4.8.1 Ignore Unsupported CIDs 244

L2CAP/COS/CID/BI-01-C [Ignore Unsupported CIDs, ACL]..... 245

L2CAP/LE/CID/BI-01-C [Ignore Unsupported CIDs, LE]..... 245

L2CAP/CLS/CID/BV-01-C [Ignore Unsupported CIDs, APB] 245

4.9 Credit Based Flow Control Mode..... 247

4.9.1 Enhanced Credit Based Flow Control Mode 247

L2CAP/ECFC/BV-01-C [L2CAP Credit Based Connection Request – Legacy Peer, LE] 248

L2CAP/ECFC/BV-45-C [L2CAP Credit Based Connection Request – Legacy Peer, BR/EDR] 248

L2CAP/ECFC/BV-02-C [L2CAP Credit Based Connection Request on Supported PSM, LE] 249

L2CAP/ECFC/BV-46-C [L2CAP Credit Based Connection Request on Supported PSM, BR/EDR] 249

L2CAP/ECFC/BV-03-C [L2CAP Credit Based Connection Response on Supported PSM, LE]..... 250



L2CAP/ECFC/BV-47-C [L2CAP Credit Based Connection Response on Supported PSM, BR/EDR] 250

L2CAP/ECFC/BV-04-C [L2CAP Credit Based Connection Request on an Unsupported PSM, LE] 251

L2CAP/ECFC/BV-48-C [L2CAP Credit Based Connection Request on an Unsupported PSM, BR/EDR] 251

L2CAP/ECFC/BV-06-C [Credit Exchange – Receiving Incremental Credits, LE]..... 252

L2CAP/ECFC/BV-49-C [Credit Exchange – Receiving Incremental Credits, BR/EDR]..... 252

L2CAP/ECFC/BV-07-C [Credit Exchange – Sending Credits, LE] 254

L2CAP/ECFC/BV-50-C [Credit Exchange – Sending Credits, BR/EDR] 254

L2CAP/ECFC/BI-01-C [Credit Exchange – Zero Credits and Exceed Maximum Credits, LE] 255

L2CAP/ECFC/BI-10-C [Credit Exchange – Zero Credits and Exceed Maximum Credits, BR/EDR] 255

L2CAP/ECFC/BI-02-C [Credit Exchange – No Credits, LE]..... 256

L2CAP/ECFC/BI-11-C [Credit Exchange – No Credits, BR/EDR]..... 256

L2CAP/ECFC/BV-11-C [Security – Insufficient Authentication – Responder, LE]..... 258

L2CAP/ECFC/BV-14-C [Security – Insufficient Encryption Key Size – Initiator, LE] 259

L2CAP/ECFC/BV-52-C [Security – Insufficient Encryption Key Size – Initiator, BR/EDR] 259

L2CAP/ECFC/BV-17-C [L2CAP Credit Based Connection Response – refused due to insufficient resources, LE]..... 260

L2CAP/ECFC/BV-53-C [L2CAP Credit Based Connection Response – refused due to insufficient resources, BR/EDR]..... 260

L2CAP/ECFC/BV-18-C [L2CAP Credit Based Connection Request – refused due to Invalid Source CID, LE] 261

L2CAP/ECFC/BV-54-C [L2CAP Credit Based Connection Request – refused due to Invalid Source CID, BR/EDR] 261

L2CAP/ECFC/BV-19-C [L2CAP Credit Based Connection Request – refused due to Source CID already allocated, LE] 263

L2CAP/ECFC/BV-55-C [L2CAP Credit Based Connection Request – refused due to Source CID already allocated, BR/EDR] 263

L2CAP/ECFC/BV-20-C [L2CAP Credit Based Connection Response – refused due to Source CID already allocated, LE] 264

L2CAP/ECFC/BV-56-C [L2CAP Credit Based Connection Response – refused due to Source CID already allocated, BR/EDR] 264

L2CAP/ECFC/BV-21-C [L2CAP Credit Based Connection Request – refused due to Unacceptable Parameters, LE]..... 265

L2CAP/ECFC/BV-57-C [L2CAP Credit Based Connection Request – refused due to Unacceptable Parameters, BR/EDR]..... 265

L2CAP/ECFC/BV-22-C [Renegotiate MTU – Initiator, LE] 267

L2CAP/ECFC/BV-58-C [Renegotiate MTU – Initiator, BR/EDR] 267

L2CAP/ECFC/BV-23-C [Renegotiate MTU – Responder, LE] 268

L2CAP/ECFC/BV-59-C [Renegotiate MTU – Responder, BR/EDR] 268

L2CAP/ECFC/BI-03-C [Renegotiate MTU – MTU value is decreased, LE]..... 270

L2CAP/ECFC/BI-12-C [Renegotiate MTU – MTU value is decreased, BR/EDR]..... 270

L2CAP/ECFC/BV-24-C [Renegotiate MPS – Initiator, LE] 271

L2CAP/ECFC/BV-60-C [Renegotiate MPS – Initiator, BR/EDR] 271

L2CAP/ECFC/BV-25-C [Renegotiate MPS – Responder, LE] 274

L2CAP/ECFC/BV-61-C [Renegotiate MPS – Responder, BR/EDR] 274

L2CAP/ECFC/BI-04-C [Renegotiate MPS – MPS value is decreased, LE]..... 276

L2CAP/ECFC/BI-13-C [Renegotiate MPS – MPS value is decreased, BR/EDR]..... 276

L2CAP/ECFC/BV-26-C [L2CAP Credit Based Connection Response – refused due to Invalid Parameters, LE]..... 277

L2CAP/ECFC/BV-62-C [L2CAP Credit Based Connection Response – refused due to Invalid Parameters, BR/EDR]..... 277

L2CAP/ECFC/BV-27-C [L2CAP Credit Based Connection Response – refused due to Unacceptable Parameters, LE]..... 278

L2CAP/ECFC/BV-63-C [L2CAP Credit Based Connection Response – refused due to Unacceptable Parameters, BR/EDR]..... 278

L2CAP/ECFC/BI-05-C [Reconfigure – refused due to invalid Destination CID, LE] 279

L2CAP/ECFC/BI-14-C [Reconfigure – refused due to invalid Destination CID, BR/EDR]..... 279



L2CAP/ECFC/BI-06-C [Reconfigure – other unacceptable parameters, LE].....	280
L2CAP/ECFC/BI-15-C [Reconfigure – other unacceptable parameters, BR/EDR]	280
L2CAP/ECFC/BV-29-C [L2CAP Credit Based Connection Response – Duplicate DCID, LE]	281
L2CAP/ECFC/BV-64-C [L2CAP Credit Based Connection Response – Duplicate DCID, BR/EDR]	281
L2CAP/ECFC/BI-07-C [L2CAP Credit Based Connection Response – Duplicate DCID, LE]	283
L2CAP/ECFC/BI-16-C [L2CAP Credit Based Connection Response – Duplicate DCID, BR/EDR]	283
4.9.2 LE Credit Based Flow Control Mode.....	283
L2CAP/LE/CFC/BV-01-C [LE Credit Based Connection Request - Legacy Peer].....	283
L2CAP/LE/CFC/BV-02-C [LE Credit Based Connection Request on Supported SPSM]	284
L2CAP/LE/CFC/BV-03-C [LE Credit Based Connection Response on Supported SPSM]	285
L2CAP/LE/CFC/BV-04-C [LE Credit Based Connection Request on an unsupported SPSM]	286
L2CAP/LE/CFC/BV-05-C [LE Credit Based Connection Request - unsupported SPSM].....	287
L2CAP/LE/CFC/BV-06-C [Credit Exchange – Receiving Incremental Credits]	288
L2CAP/LE/CFC/BV-07-C [Credit Exchange – Sending Credits]	290
L2CAP/LE/CFC/BI-01-C [Credit Exchange – Exceed Initial Credits].....	291
L2CAP/LE/CFC/BV-11-C [Security - Insufficient Authentication – Responder].....	292
L2CAP/LE/CFC/BV-14-C [Security - Insufficient Encryption Key Size – Initiator]	292
L2CAP/LE/CFC/BV-17-C [LE Credit Based Connection Response - refused due to insufficient resources - Responder]	293
L2CAP/LE/CFC/BV-18-C [LE Credit Based Connection Request - refused due to Invalid Source CID - Initiator]	294
L2CAP/LE/CFC/BV-19-C [LE Credit Based Connection Request - refused due to source CID already allocated - Initiator].....	295
L2CAP/LE/CFC/BV-20-C [LE Credit Based Connection Response - refused due to Source CID already allocated - Responder].....	296
L2CAP/LE/CFC/BV-21-C [LE Credit Based Connection Request - refused due to Unacceptable Parameters - Initiator]	297
L2CAP/ECFC/BV-38-C [Credit Based Connection Request Dynamically Allocated Source CID – LE]	299
L2CAP/LE/CFC/BV-29-C [Credit Based Connection Request Dynamically Allocated Source CID].....	299
L2CAP/ECFC/BV-79-C [Credit Based Connection Request Dynamically Allocated Source CID – BR/EDR]	299
4.9.3 All Credit Based Flow Control Mode	300
L2CAP/LE/CFC/BV-08-C [Disconnection Request]	301
L2CAP/ECFC/BV-08-C [Disconnection Request, LE]	301
L2CAP/ECFC/BV-65-C [Disconnection Request, BR/EDR].....	301
L2CAP/LE/CFC/BV-09-C [Disconnection Response].....	303
L2CAP/ECFC/BV-09-C [Disconnection Response, LE]	303
L2CAP/ECFC/BV-66-C [Disconnection Response, BR/EDR]	303
L2CAP/LE/CFC/BV-10-C [Security – Insufficient Authentication – Initiator].....	305
L2CAP/ECFC/BV-10-C [Security – Insufficient Authentication – Initiator, LE]	305
L2CAP/ECFC/BV-67-C [Security – Insufficient Authentication – Initiator, BR/EDR]	305
L2CAP/LE/CFC/BV-12-C [Security – Insufficient Authorization – Initiator].....	307
L2CAP/ECFC/BV-12-C [Security – Insufficient Authorization – Initiator, LE]	307
L2CAP/ECFC/BV-68-C [Security – Insufficient Authorization – Initiator, BR/EDR]	307
L2CAP/LE/CFC/BV-13-C [Security – Insufficient Authorization – Responder].....	309
L2CAP/ECFC/BV-13-C [Security – Insufficient Authorization – Responder, LE].....	309
L2CAP/LE/CFC/BV-15-C [Security – Insufficient Encryption Key Size – Responder].....	311
L2CAP/ECFC/BV-15-C [Security – Insufficient Encryption Key Size – Responder, LE]	311
L2CAP/ECFC/BV-70-C [Security – Insufficient Encryption Key Size – Responder, BR/EDR]	311
L2CAP/LE/CFC/BV-16-C [L2CAP LE Credit Based Connection Request – refused due to insufficient resources]	314
L2CAP/ECFC/BV-16-C [L2CAP Credit Based Connection Request – refused due to insufficient resources, LE].....	314
L2CAP/ECFC/BV-71-C [L2CAP Credit Based Connection Request – refused due to insufficient resources, BR/EDR].....	314
L2CAP/LE/CFC/BV-22-C [L2CAP LE Credit Based Connection Response on Unsupported SPSM]	316

L2CAP/ECFC/BV-28-C [L2CAP Credit Based Connection Response on Unsupported SPSM, LE]	316
L2CAP/ECFC/BV-72-C [L2CAP Credit Based Connection Response on Unsupported SPSM, BR/EDR]	316
L2CAP/LE/CFC/BV-23-C [Disconnect Request – DCID not recognized or fixed channel]	318
L2CAP/ECFC/BV-30-C [Disconnection Response – DCID not recognized or fixed channel, LE]	318
L2CAP/ECFC/BV-73-C [Disconnection Response – DCID not recognized or fixed channel, BR/EDR]	318
L2CAP/LE/CFC/BV-24-C [Security – Insufficient Encryption – Initiator]	320
L2CAP/ECFC/BV-31-C [Security – Insufficient Encryption – Initiator, LE]	320
L2CAP/LE/CFC/BV-25-C [Security – Insufficient Encryption – Responder]	322
L2CAP/ECFC/BV-32-C [Security – Insufficient Encryption – Responder, LE]	322
L2CAP/LE/CFC/BV-26-C [K-frame – SDU length greater than MTU of IUT]	324
L2CAP/ECFC/BV-33-C [K-frame – SDU length greater than MTU of IUT, LE]	324
L2CAP/ECFC/BV-76-C [K-frame – SDU length greater than MTU of IUT, BR/EDR]	324
L2CAP/LE/CFC/BV-27-C [K-frame – Information Payload length greater than MPS of IUT]	326
L2CAP/ECFC/BV-34-C [K-frame – Information Payload length greater than MPS of IUT, LE]	326
L2CAP/ECFC/BV-77-C [K-frame – Information Payload length greater than MPS of IUT, BR/EDR]	326
L2CAP/LE/CFC/BV-28-C [Total length of segments greater than SDU length specified in first K-frame]	328
L2CAP/ECFC/BV-35-C [Total length of segments greater than SDU length specified in first K-frame, LE]	328
L2CAP/ECFC/BV-78-C [Total length of segments greater than SDU length specified in first K-frame, BR/EDR]	328
L2CAP/LE/CFC/BV-32-C [K-frame – SDU length = MPS]	330
L2CAP/ECFC/BV-80-C [K-frame – SDU length = MPS, LE]	330
L2CAP/ECFC/BV-81-C [K-frame – SDU length = MPS, BR/EDR]	330
4.10 Generic Attribute Timing tests	332
4.10.1 Back-off on Connection Request Collision	332
L2CAP/TIM/BV-01-C [Back-off on Connection Request Collision, BR/EDR, Dynamic]	333
L2CAP/TIM/BV-02-C [Back-off on Connection Request Collision, BR/EDR, EATT]	333
L2CAP/TIM/BV-03-C [Back-off on Connection Request Collision, LE, EATT]	333
5 Test case mapping	336
6 Revision history and acknowledgments	346

1 Scope

This Bluetooth document contains the Test Suite Structure (TSS) and test cases to test the implementation of the Bluetooth Logical Link Control and Adaptation Protocol (L2CAP) layer with the objective to provide a high probability of air interface interoperability between the tested implementation and other manufacturers' Bluetooth devices.

2 References, definitions, and abbreviations

2.1 References

This document incorporates provisions from other publications by dated or undated reference. These references are cited at the appropriate places in the text, and the publications are listed hereafter. Additional definitions and abbreviations can be found in [9] and [10].

- [1] Specification of the Bluetooth System, Version 1.2 or later, Volume 3, Part A
- [2] ISO/IEC 9646-1 "Conformance Testing Methodology and Framework"
- [3] Core IXIT Proforma for Bluetooth Conformance Test Suites
- [4] Specification of the Bluetooth System, Version 2.0 / 2.0+EDR / 2.1 / 2.1+EDR
- [5] ICS Proforma for Logical Link Control and Adaption Protocol (L2CAP)
- [6] ITU-T Recommendation Z.120, Message Sequence Chart (MSC)
- [7] Core Specification Addendum 1 (CSA1)
- [8] Specification of the Bluetooth System, Version 3.0 +HS or later, Volume 3, Part A
- [9] Specification of the Bluetooth System, Volume 2, Part C
- [10] Volume 1, Part A, Test Strategy and Terminology Overview
- [11] Specification of the Bluetooth System, Version 4.0 or later, Volume 3, Part A (L2CAP)
- [12] Specification of the Bluetooth System, Version 4.1 or later, Volume 3, Part A (L2CAP)
- [13] Specification of the Bluetooth System, Volume 3, Part A (Logical Link Control and Adaptation Protocol Specification), Version 5.2 or later
- [14] Specification of the Bluetooth System, Volume 3, Part G (Generic Attribute Profile Specification), Version 5.2 or later
- [15] Specification of the Bluetooth System, Volume 3, Part A (Logical Link Control and Adaptation Protocol Specification), Version 5.3 or later
- [16] Security Manager Test Suite, SM.TS
- [17] Link Manager Protocol Test Suite, LMP.TS
- [18] [Appropriate Language Mapping Tables](#) document
- [19] Specification of the Bluetooth System, Version 6.3 or later, Volume 3, Part A (L2CAP)

2.2 Definitions

In this Bluetooth document, the definitions from [9] and [10] apply.

Certain terms that were identified as inappropriate have been replaced. For a list of the original terms and their replacement terms, see the Appropriate Language Mapping Tables document [18].

2.3 Acronyms and abbreviations

In this Bluetooth document, the definitions, acronyms, and abbreviations from [9] and [10] apply.



3 Test Suite Structure (TSS)

3.1 Test Strategy

The test objectives are to verify the functionality of the L2CAP layer within a Bluetooth Host and enable interoperability between Bluetooth Hosts on different devices. The testing approach covers mandatory and optional requirements in the specification and matches these to the support of the IUT as described in the ICS. At the same time, unless specifically prohibited by a test procedure, it is acceptable for IUTs to send redundant PDUs not described by the test procedure. When observed, such PDUs do not result in a test case failure. Any defined test herein is applicable to the IUT if the ICS logical expression defined in the Test Case Mapping Table (TCMT) evaluates to true.

The test equipment provides an implementation of the Radio Controller and the parts of the Host needed to perform the test cases defined in this Test Suite. A Lower Tester acts as the IUT's peer device and interacts with the IUT over-the-air interface. The configuration, including the IUT, needs to implement similar capabilities to communicate with the test equipment. For some test cases, it is necessary to stimulate the IUT from an Upper Tester. In practice, this could be implemented as a special test interface, a Man Machine Interface (MMI), or another interface supported by the IUT.

This Test Suite contains Valid Behavior (BV) tests complemented with Invalid Behavior (BI) tests where required. The test coverage mirrored in the Test Suite Structure is the result of a process that started with catalogued specification requirements that were logically grouped and assessed for testability enabling coverage in defined test purposes.

The L2CAP layer specifies three groups of services:

- CONNECTION ORIENTED basic L2CAP mode
- CONNECTION ORIENTED retransmission/flow control/streaming modes
- CONNECTIONLESS basic L2CAP mode

The Test Suite Structure is a tree with the first level defined as L2CAP representing the protocol services. From these services, the test groups and functional modules are derived.

3.2 Test groups

Tests are defined in terms of a sequence of L2CAP and AMP Manager operations in the Implementation Under Test (IUT) and over-the-air interface operations.

The test groups are organized in three levels. The first level defines the protocol groups representing the protocol services. The second level separates the protocol services in functional modules. The last level in each branch contains the standard ISO subgroups BV and BI.

3.2.1 Protocol service groups

The protocol groups identify the Bluetooth L2CAP Layer services Connection-Oriented Services and the Connectionless Service.

3.2.1.1 Connection-Oriented Service – Basic L2CAP Mode

With the functional modules:

- Basic operation data channel
- Configuration of data channel
- Implementation-specific information exchange
- Echo handling

3.2.1.2 Connection-Oriented Service – Retransmission/Flow Control/Streaming Modes

- Flow control mode
- Retransmission mode
- Extended features
- Channel mode configuration
- Frame check sequence (FCS) option configuration
- Optional FCS
- Enhanced retransmission mode
- Streaming mode
- Extended features
- Fixed channel support
- Extended window size configuration
- Lock step configuration
- LE credit based flow control mode
- Enhanced credit based flow control mode
- Create channel
- Move channel
- Enhanced retransmission mode with extended control field
- Streaming mode with extended control field

3.2.1.3 Low Energy System tests

- Connection parameter update
- Command reject

3.2.1.4 Connectionless Service

- Connectionless reception channel



3.2.2 Main test groups

3.2.2.1 Fixed Channel Support

The Generic AMP defines a method to determine if a device supports fixed channels beyond the two currently defined. A fixed channel is present as soon as the ACL link is created. These fixed channels can be used for the AMP Manager protocol and other protocols in the future.

Refer to [8] Section 2.1 for a list of the characteristics of each fixed channel (e.g., reliability, MTU size, QoS). Table 2.1 in Section 2.1 lists the defined fixed channels and provides a reference to where the associated channel characteristics are defined.

3.2.2.2 AMP Manager Channel Support

The AMP Manager protocol uses L2CAP fixed channel 3 for communication between individual device AMP Managers. These tests relate to the creation of AMP channels and moving data channels between AMPs and the BR/EDR controllers.

3.2.2.3 AMP Manager Protocol

The AMP Manager provides information on available AMPs and their characteristics to other AMP capable Bluetooth devices. These tests relate to AMP Discovery, info exchange and change in available AMP status.

3.2.2.4 AMP Manager Physical Channel Interface

The AMP Manager must be able to acquire AMP info from the local available AMPs. These tests relate to AMP Manager / AMP HCI / AMP PAL interface and control. The interface and exchange of information is defined in terms of AMP HCI command packets and events. Note that a specific instance of a Bluetooth stack and AMP PAL may not necessarily need to exchange an AMP HCI Packet if the interaction between the layers “acts” as if an AMP HCI packet was exchanged.

3.2.2.5 Low Energy Signaling Channel Support

The Low Energy Signaling channel uses L2CAP fixed channel 5 for communication between Low energy capable devices.

3.2.3 Behavior testing groups

3.2.3.1 Valid Behavior (BV) tests

This sub group provides testing to verify that the IUT reacts in conformity with the Bluetooth standard, after receipt or exchange of a valid Protocol Data Units (PDUs). Valid PDUs means that the exchange of messages and the content of the exchanged messages are considered as valid.

3.2.3.2 Invalid Behavior (BI) tests

This sub group provides testing to verify that the IUT reacts in conformity with the Bluetooth standard, after receipt of a syntactically or semantically invalid PDU.

4 Test cases (TC)

4.1 Introduction

4.1.1 Test case identification conventions

Test cases are assigned unique identifiers per the conventions in [10]. The convention used here is: **<spec abbreviation>/<IUT role>/<class>/<feat>/<func>/<subfunc>/<cap>/<xx>-<nn>-<y>**.

Identifier Abbreviation	Spec Identifier <spec abbreviation>
L2CAP	Logical Link Control and Adaptation Protocol
Identifier Abbreviation	Function Identifier <func>
CLS	Connectionless services
COS	Connection-oriented services
LE	Low Energy signaling channel
Identifier Abbreviation	Subfunction Identifier <subfunc>
CCH	Create Channel
CED	Basic operation data channel
CFC	LE Credit Based Flow Control Mode
CFD	Configuration of data channel
CID	Channel Identifiers
CLR	Connectionless reception channel
CMC	Channel Mode configuration
CPU	Connection Parameter Update
ECF	Enhanced Retransmission Mode using Extended Control Field
ECH	Echo handling
ERM	Use of Enhanced Retransmission Mode
EWC	Extended Window Size Configuration
EXF	Extended Features
FIX	Fixed Channel Support
FLC	Flow control mode
FOC	Optional FCS configuration
IEX	Implementation-specific information exchange
LSC	Lock Step Configuration
MCH	Move Channel
OFS	Use of Optional FCS
REJ	Command reject
RTX	Retransmission mode
STM	Streaming Mode
UCD	Unicast Connectionless Data
Identifier Abbreviation	Class Identifier <class>
TIM	Generic Attribute Timing Tests

Item	Support
ECFC	Enhanced Credit Based Flow Control Mode

Table 4.1: L2CAP TC feature naming conventions

4.1.2 MSC abbreviations

Table 4.2 provides the definitions of abbreviations used in the test case MSCs.

MSC Abbr	Use in Frame	Description	Reference
N(S)	I-Frame	Send sequence number. N(S) is equivalent to TxSeq use in [1].	[1] 3.3.2
SAR	I-Frame	I-Frame Segmentation And Reassembly indicator (i.e., Un-segmented SDU / Start, Continuation, End of SDU)	[1] 3.3.2
N(R)	I/S-Frame	Receive sequence number. N(R) is equivalent to ReqSeq use in [1].	[1] 3.3.2
F	I/S-Frame	Final Bit	[1] 3.3.2
P	S-Frame	Poll Bit	[1] 3.3.2
RR	S-Frame	S-Frame Supervisory Function = Receiver Ready	[1] 3.3.2
RNR	S-Frame	S-Frame Supervisory Function = Receiver Not Ready	[1] 3.3.2
REJ	S-Frame	S-Frame Supervisory Function = Reject	[1] 3.3.2
SREJ	S-Frame	S-Frame Supervisory Function = Selective Reject	[1] 3.3.2

Table 4.2: MSC abbreviations

4.1.3 Conformance

When conformance is claimed for a particular specification, all capabilities are to be supported in the specified manner. The mandated tests from this Test Suite depend on the capabilities to which conformance is claimed.

The Bluetooth Qualification Program may employ tests to verify implementation robustness. The level of implementation robustness that is verified varies from one specification to another and may be revised for cause based on interoperability issues found in the market.

Such tests may verify:

- That claimed capabilities may be used in any order and any number of repetitions not excluded by the specification
- That capabilities enabled by the implementations are sustained over durations expected by the use case
- That the implementation gracefully handles any quantity of data expected by the use case
- That in cases where more than one valid interpretation of the specification exists, the implementation complies with at least one interpretation and gracefully handles other interpretations
- That the implementation is immune to attempted security exploits

A single execution of each of the required tests is required to constitute a Pass verdict. However, it is noted that to provide a foundation for interoperability, it is necessary that a qualified implementation consistently and repeatedly pass any of the applicable tests.



In any case, where a member finds an issue with the test plan generated by the Bluetooth SIG qualification tool, with the test case as described in the Test Suite, or with the test system utilized, the member is required to notify the responsible party via an erratum request such that the issue may be addressed.

4.1.4 Lower layer assumptions

For conformance testing L2CAP and enhanced L2CAP layers it is necessary to have working lower layers in conformance with lower layer specifications.

For testing it is necessary to have an ACL link between the Lower Tester and IUT set up.

For connection-oriented operation no more than one ACL link exists between an IUT and the Lower Tester.

In the L2CAP test cases the IUT may act either as L2CAP initiator or as L2CAP acceptor. In each test case is defined which of these roles apply. The L2CAP initiator is assumed to be the Central of the piconet when executing these tests.

4.1.5 Upper Tester

For some test cases, it is necessary to stimulate the IUT from an Upper Tester. In practice, this could be special test interface, an MMI, or other interface as supported by the IUT.

4.1.6 General information about MSC

The reception of L2CAP_CONFIGURATION_REQ/RSP PDUs from the IUT by the Lower Tester is described in more detail in [6] Section 5.2. The MSC diagrams for each Test Case only reflect the case where these PDUs are not segmented by IUT. If segmentation occurs, the MSC diagrams for each Test Case can be seen as the final outcome of the configuration procedure.

4.1.7 Pass/Fail verdict conventions

Each test case has an Expected Outcome section. The IUT is granted the Pass verdict when all the detailed pass criteria conditions within the Expected Outcome section are met.

The convention in this Test Suite is that, unless there is a specific set of fail conditions outlined in the test case, the IUT fails the test case as soon as one of the pass criteria conditions cannot be met. If this occurs, then the outcome of the test is a Fail verdict.

4.2 Preamble IXITs

The following IXIT items are defined to assist with general establishment of initial conditions. As such they are noted here rather than in specific tests.

TSPX_iut_device_name_in_adv_packet_for_random_address	Device Name. IUT advertising this local name for the Lower Tester to make connection to. The default is that this not using it with empty string.
TSPX_time_guard	The time in ms, for the Lower Tester to wait for a specific event.
TSPX_security_enabled	Indicates if security is required, to establish connections, by the IUT.
TSPX_delete_ltk	Indicates whether to delete Long Term Key or not.

TSPX_delete_link_key	Determine whether the Lower Tester has to delete the stored link key in the beginning of each test case.
TSPX_use_dynamic_pin	Determines whether a dynamic PIN MMI edit box will be used for Dynamic Lower Tester Pin.
TSPX_secure_simple_pairing_pass_key_confirmation	Determines whether manual confirmation on generated key is required during secure simple pairing.

Table 4.3: Preamble IXITs

4.3 Common Packet Contents

4.3.1 Fields and Bits Reserved for Future Use

Unless a specific test states otherwise, all fields within packets and all bits within fields that are described as reserved for future use are set to 0 in packets sent by the Upper and Lower Testers.

4.4 Connection-Oriented Basic L2CAP mode

Verify the correct implementation of the connection-oriented services of the L2CAP layer.

4.4.1 Basic Operation Data Channel CED

Verify the basic procedures for connection establishment of a data channel. That describes the setup phases, the data exchange and the release.

L2CAP/COS/CED/BV-01-C [Request Connection]

- Test Purpose

Verify that the IUT can request the connection establishment for an L2CAP data channel and initiate the configuration procedure.

- Reference

[1] Table 2.1, Table 6.1, 2.2, 4.2, 4.3

- Initial Condition

- The IUT is in CLOSED state for data channel. No ACL link is established.
- It must be possible to send a connection request from the Upper Tester to create an L2CAP channel.

- Test Procedure

ACL link establishment is part of the test case. The Lower Tester imposes 48 byte MTU for both configuration directions.

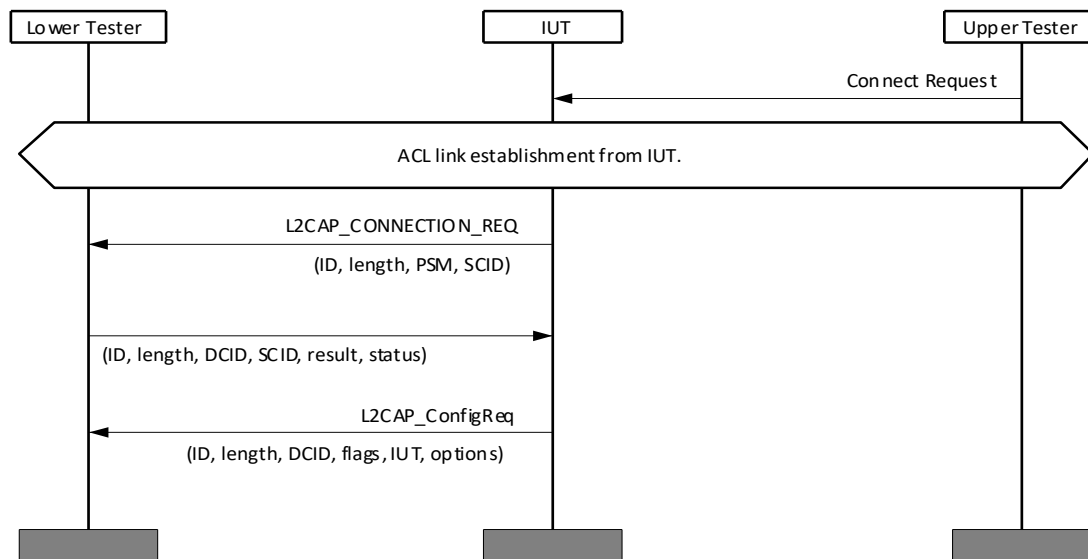

Figure 4.1: L2CAP/COS/CED/BV-01-C [Request Connection] MSC

- Test Condition

The Lower Tester utilizes version L2CAP Basic Mode.

The Lower Tester's Bluetooth device address BD_ADDR is defined. For parameters to send and receive, see [5].

The IUT acts as L2CAP initiator.

- Expected Outcome

Pass verdict

The IUT transmits L2CAP_CONNECTION_REQ over the signaling channel and dynamically allocates an SCID.

The IUT initiates the configuration process as indicated by the generation of an L2CAP_CONFIGURATION_REQ.

The IUT accepts configuration of the MTU=48 bytes.

L2CAP/COS/CED/BV-03-C [Send Data]

- Test Purpose

Verify that the IUT can send DATA.

- Reference

[1] Table 6.1, Section 4

- Initial Condition

- The Lower Tester utilizes version L2CAP Basic Mode.
- The IUT is in the OPEN state for a data channel with assigned SCID and DCID. The IUT acts either as L2CAP initiator or as L2CAP acceptor.

- Test Procedure

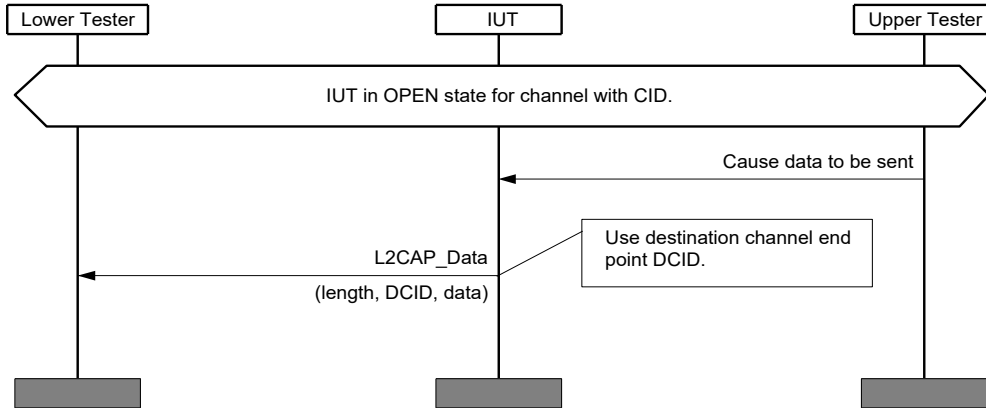

Figure 4.2: L2CAP/COS/CED/BV-03-C [Send Data] MSC

- Expected Outcome

Pass verdict

The IUT transmits L2CAP_Data over the assigned channel with correct DCID assigned by the Lower Tester.

L2CAP/COS/CED/BV-04-C [Disconnect]

- Test Purpose

Verify that the IUT can disconnect the data channel.

- Reference

[1] Table 2.2, Table 6.1, 2.2, 4, 4.6

- Initial Condition

- The Lower Tester utilizes version L2CAP Basic Mode.
- The IUT is in the OPEN state for a data channel with assigned SCID and DCID. The IUT acts either as L2CAP initiator or as L2CAP acceptor.

- Test Procedure

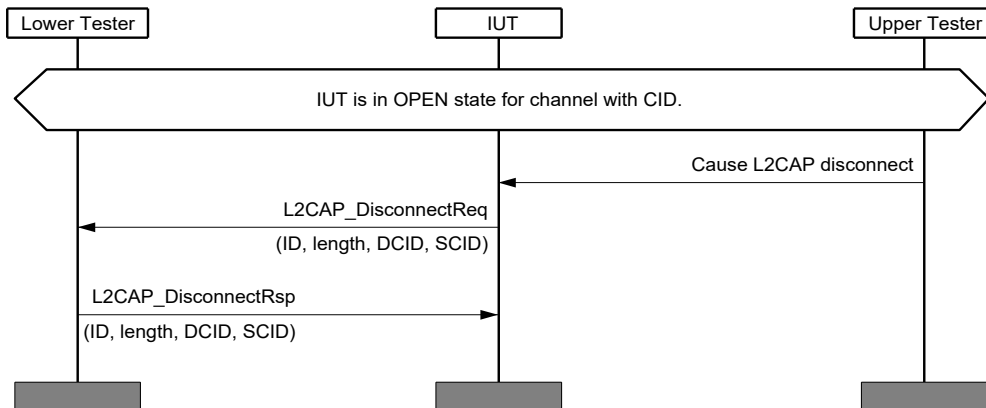

Figure 4.3: L2CAP/COS/CED/BV-04-C [Disconnect] MSC

- Expected Outcome

Pass verdict

The IUT transmits a correct L2CAP_DISCONNECTION_REQ.

L2CAP/COS/CED/BV-07-C [Accept Disconnect]

- Test Purpose

Verify that the IUT can respond to the request to disconnect the data channel.

- Reference

[1] Table 2.2, Table 6.1, 2.2, 4, 4.4, 4.5

- Initial Condition

- The Lower Tester utilizes version L2CAP Basic Mode.
- The IUT is in OPEN state for a data channel with assigned CID. The IUT acts either as L2CAP initiator or as L2CAP acceptor.

- Test Procedure

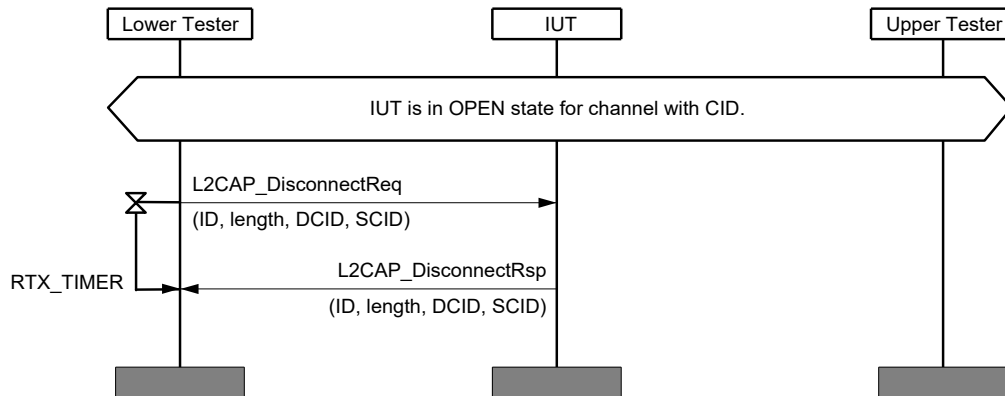

Figure 4.4: L2CAP/COS/CED/BV-07-C [Accept Disconnect] MSC

- Expected Outcome

Pass verdict

The IUT sends a correct L2CAP_DISCONNECTION_RSP before the RTX timer expires.

- Notes

The Lower Tester's RTX timer is set to TSPX_timer_rtx_max.

L2CAP/COS/CED/BV-08-C [Disconnect on Timeout]

- Test Purpose

Verify that the IUT disconnects the data channel and shuts down this channel if no response occurs.

- Reference

[1] 4.6, 4.7, 6.2.1

- Initial Condition
 - The Lower Tester utilizes version L2CAP Basic Mode.
 - The IUT is in WAIT CONFIG state for a data channel with assigned CID.
 - The IUT acts either as L2CAP initiator or as L2CAP acceptor.
- Test Procedure

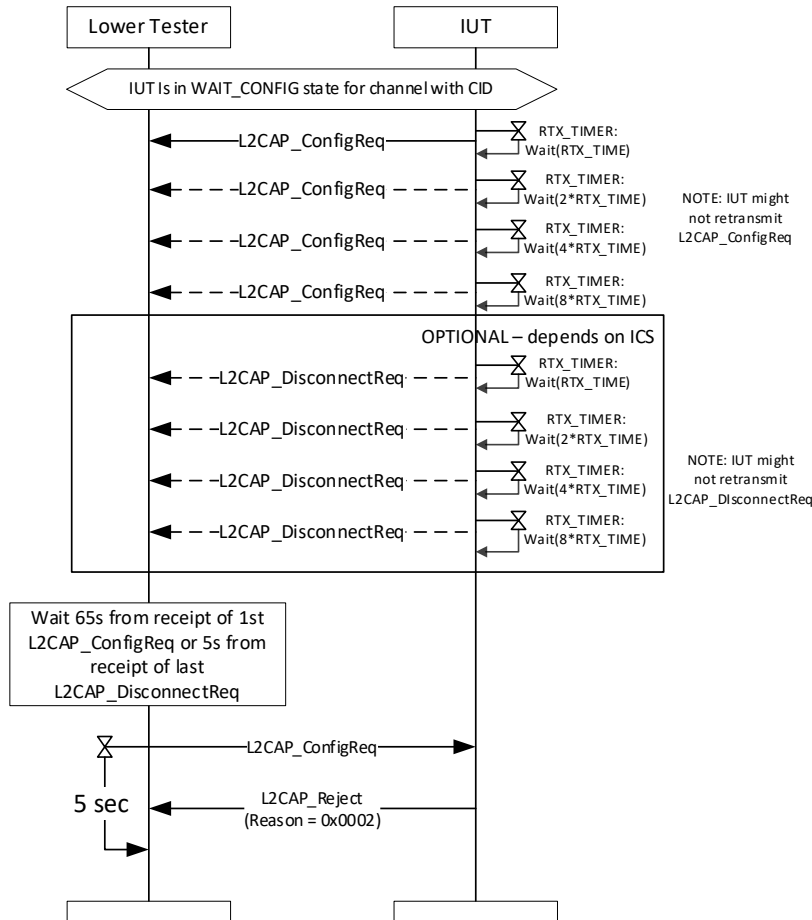

Figure 4.5: L2CAP/COS/CED/BV-08-C [Disconnect on Timeout] MSC

The Lower Tester transmits L2CAP_CONFIGURATION_REQ 5 seconds after receiving the last L2CAP_DISCONNECTION_REQ or 65 seconds after receiving the first L2CAP ConfigReq.

The IUT sends an L2CAP_COMMAND_REJECT_RSP with reason 0x0002 “Invalid CID in request” in response to the L2CAP_CONFIGURATION_REQ received.

The supplier may be required to state the number of L2CAP_DISCONNECTION_REQ retransmissions that the IUT performs.

Following the expiration of TSPX_timer_rtx, it is possible that the IUT terminates the ACL – in this case the test stops.

- Expected Outcome

Pass verdict

The IUT sends a correctly formatted L2CAP_CONFIGURATION_REQ to the Lower Tester.

If the IUT retransmits the L2CAP_CONFIGURATION_REQ more than once, each subsequent delay is at least twice the previous delay, and the identifier used for the original transmission is also used for each retransmission.

If the IUT sends an L2CAP_DISCONNECTION_REQ, it is correctly formatted.

If the IUT retransmits the L2CAP_DISCONNECTION_REQ more than once, each subsequent delay is at least twice the previous delay, and the identifier used for the original transmission is also used for each retransmission.

The IUT may terminate the ACL at the expiration of the RTX timer.

If the IUT does not terminate the ACL:

- The IUT does not transmit an L2CAP_CONFIGURATION_RSP to the Lower Tester within 5 seconds of the L2CAP_CONFIGURATION_REQ sent by the Lower Tester.
- The IUT sends an L2CAP_COMMAND_REJECT_RSP with reason 0x0002 "Invalid CID in request" in response to the L2CAP_CONFIGURATION_REQ received.

L2CAP/COS/CED/BV-09-C [Receive Multi-Command Packet]

- Test Purpose

Verify that the IUT can receive more than one signaling command in one L2CAP packet.

- Reference

[1] 4

- Initial Condition

- Either the IUT initiated the connection or the Lower Tester initiated the connection and the IUT is in CONFIG state for a data channel with assigned CID. The IUT may act as either L2CAP initiator or L2CAP acceptor. Either the initiator or responder can send the first L2CAP_CONFIGURATION_REQ.

- Test Procedure

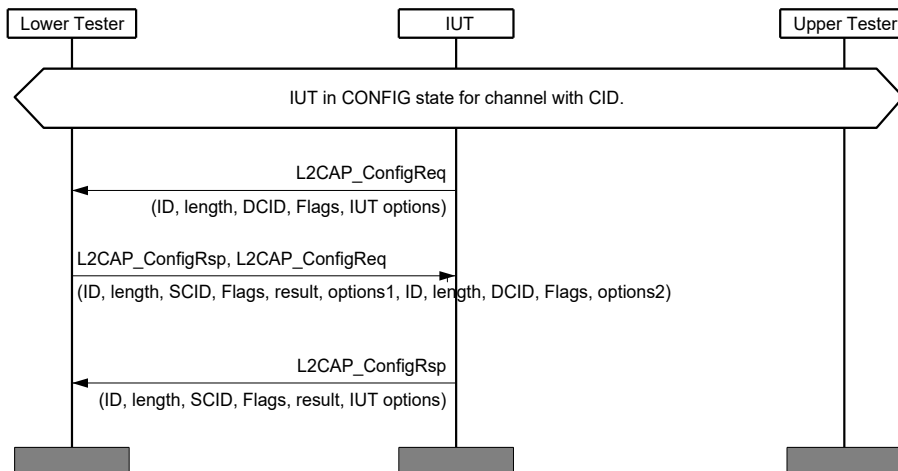

Figure 4.6: L2CAP/COS/CED/BV-09-C [Receive Multi-Command Packet] MSC



- Expected Outcome

Pass verdict

ALT1:

The IUT sends a correctly formatted L2CAP_CONFIGURATION_REQ to the Lower Tester, the first on the CID, and, having received an L2CAP_CONFIGURATION_RSP and an L2CAP_CONFIGURATION_REQ in a single L2CAP packet from the Lower Tester, sends a correctly formatted L2CAP_CONFIGURATION_RSP to the Lower Tester within 60s.

ALT2:

The IUT, having received the first L2CAP_CONFIGURATION_REQ from the Lower Tester and having sent a correctly formatted L2CAP_CONFIGURATION_RSP to the Lower Tester, sends a correctly formatted L2CAP_CONFIGURATION_REQ to the Lower Tester and, upon reception of an L2CAP_CONFIGURATION_RSP and an L2CAP_ECHO_REQ in a single L2CAP packet from the Lower Tester, sends an L2CAP_ECHO_RSP to the Lower Tester within 60s.

L2CAP/COS/CED/BV-10-C [Transmit I-frames]

- Test Purpose

Verify that IUT can transmit I-frames including correct CRC.

- Reference

[1] 5.4, 7.4

- Initial Condition

- The IUT is in OPEN state for data channel with assigned CID. L2CAP connection configured as Flow Control only mode.

- Test Procedure

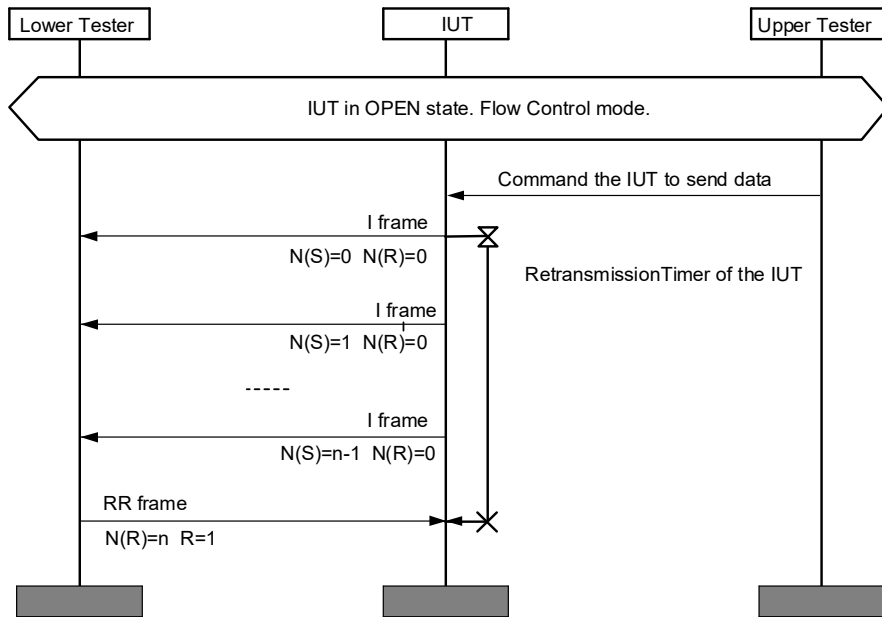

Figure 4.7: L2CAP/COS/CED/BV-10-C [Transmit I-frames] MSC

- Expected Outcome

Pass verdict

The IUT sends I-frames until TxWindow is full.

Data in the I-frames matches that provided by the Upper Tester. CRC value is set per the specification.

L2CAP/COS/CED/BV-11-C [Configure MTU Size]

- Test Purpose

Verify that the IUT can configure the supported MTU size.

- Reference

[1] 5

- Initial Condition

- Maximum supported MTU size set in TSPX_I2ca_inmtu.
- The IUT acts either as L2CAP initiator or as L2CAP acceptor.

- Test Procedure

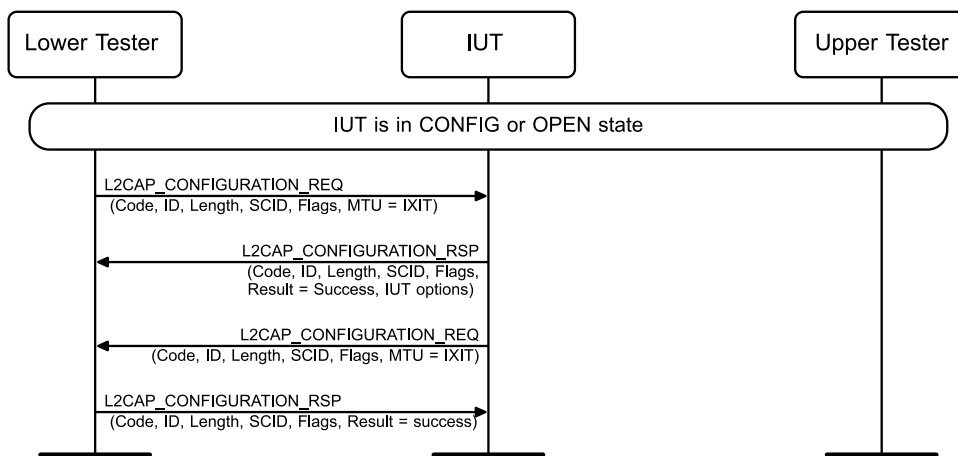

Figure 4.8: L2CAP/COS/CED/BV-11-C [Configure MTU Size] MSC

- Expected Outcome

Pass verdict

The IUT sends a correct L2CAP_CONFIGURATION_RSP to the Lower Tester accepting the MTU.

The IUT sends a correct L2CAP_CONFIGURATION_REQ to the Lower Tester indicating maximum supported MTU.

L2CAP/COS/CED/BV-12-C [Recombination of Signaling Packets]

- Test Purpose

Verify that the IUT correctly handles fragmented L2CAP signaling PDUs.

- Reference

[1] 3.1, 4.2, 4.3, 7.2.2



- Initial Condition
 - The Lower Tester utilizes version L2CAP Basic Mode.
 - The IUT is in CLOSED state. No ACL link is established. The IUT acts as L2CAP acceptor.
- Test Procedure

The IUT waits for all the fragments of each C-frame before interpreting the latter, i.e., until the received size of the C-frame equals the value of the PDU Length field of the C-frame + length of the L2CAP header (4 octets).

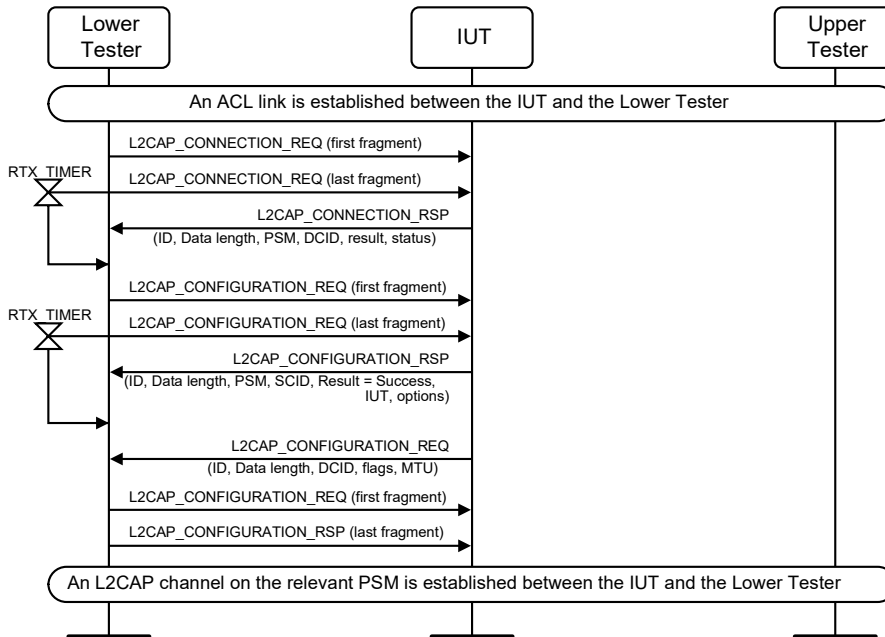

Figure 4.9: L2CAP/COS/CED/BV-12-C [Recombination of Signaling Packets] MSC

- Expected Outcome

Pass verdict

The IUT sends correct L2CAP signaling PDUs before the RTX timer expires in response to the correctly recombined L2CAP PDUs sent by the Lower Tester.

- Notes

The Lower Tester’s RTX timer is set to maximum allowed initial value.

It is allowed for the IUT to fragment its signaling packets, as well.

L2CAP/COS/CED/BI-03-C [Incorrect PDU Length, Received Data Packet, Basic]

- Test Purpose

Verify that the IUT properly handles L2CAP Data PDUs that have an invalid PDU length.

- Reference

[1] 3.1, 4

- Initial Condition
 - The Lower Tester uses version L2CAP Basic Mode.
 - No security is used in this test case.
 - The IUT is in the OPEN state with the BR/EDR transport for a data channel with assigned SCID and DCID. The IUT acts either as L2CAP initiator or as L2CAP acceptor.
- Test Procedure
 1. The Lower Tester sends an L2CAP Data PDU to the IUT with LLID set to 0b10, PDU Length set to 3, and 4 octets of Information Payload Data.
 2. Perform alternative 2A, 2B, or 2C depending on the IUT's response.
 - Alternative 2A (IUT terminates the link):
 - 2A.1 The IUT terminates the link.
 - 2A.2 The test ends with a Pass verdict.
 - Alternative 2B (IUT discards the frame):
 - 2B.1 The IUT discards the frame.
 - 2B.2 The IUT does not send data to the Upper Tester.
 - Alternative 2C (Any other IUT response):
 - 2C.1 The Upper Tester issues a warning and the test ends.
 3. The Lower Tester sends an L2CAP Data PDU to the IUT with LLID set to 0b10, PDU Length set to 4, and 4 octets of Information Payload Data.
 4. The IUT sends the data received in Step 3 to the Upper Tester.

- Test Condition

Reliability for the basic mode channel is not needed, so the first PDU in Step 1 can be silently discarded. The IUT can use a finite flush timeout or an ERTM channel.

- Expected Outcome

Pass verdict

In Step 2A.1, the IUT terminates the link.

In Step 2B.2, the IUT does not send the data from Step 1 to the Upper Tester.

In Step 2C.1, the IUT sends any valid response.

In Step 4, the IUT sends the data received in Step 3 to the Upper Tester.

L2CAP/COS/CED/BI-30-C [Accept Reject of Connection Request, Peer Older Than v4.2]

- Test Purpose

Verify that the IUT can request the connection establishment for an L2CAP data channel and initiate the configuration procedure.
- Reference

[19] 4.3
- Initial Condition
 - The IUT is an L2CAP Initiator.
 - The IUT is in CLOSED state for data channel. No ACL link is established.
 - It must be possible to send a connection request from the Upper Tester to create an L2CAP channel.

- The Lower Tester's Bluetooth device address BD_ADDR is defined. For parameters to send and receive, see [5].
- The Lower Tester is configured to support Core v4.1.
- Test Procedure

ACL link establishment is part of the test case. The Lower Tester imposes 48 byte MTU for both configuration directions.

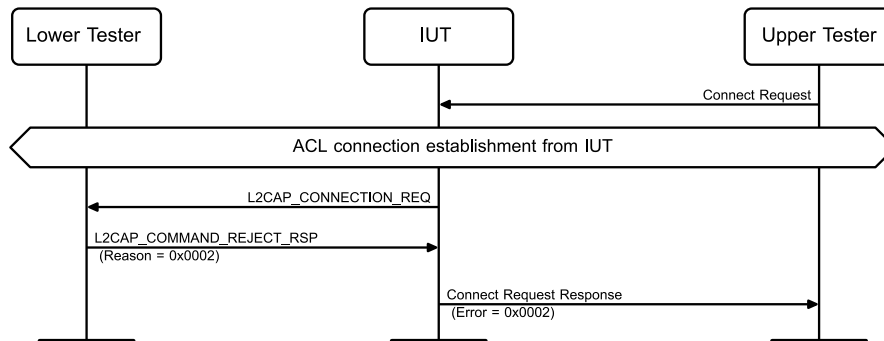

Figure 4.10: L2CAP/COS/CED/BI-30-C [Accept Reject of Connection Request, Peer Older Than v4.2] MSC

1. The Upper Tester commands the IUT to send a connection request.
2. The IUT sends an L2CAP_CONNECTION_REQ PDU to the Lower Tester.
3. The Lower Tester sends an L2CAP_COMMAND_REJECT_RSP PDU with Reason set to 0x0002.
4. The IUT sends a connection request response to the Upper Tester with an 0x0002 error.

- Expected Outcome

Pass verdict

In Step 4, the IUT sends an 0x0002 error.

4.4.1.1 Incorrect PDU Length, C-Frame

- Test Purpose

Verify that the IUT properly handles L2CAP C-Frame PDUs that have an invalid PDU length.

- Reference

[1] 3.1, 4

- Initial Condition

- The Lower Tester uses version L2CAP Basic Mode.
- No security is used in this test case.
- The L2CAP signaling channel specified in Table 4.4 is established between the IUT and the Lower Tester.
- The IUT is in CLOSED state and acts as an L2CAP acceptor.

- Test Case Configuration

Test Case	Transport	Signaling Channel	L2CAP payload/ PDU_Length/ Payload Length
L2CAP/COS/CED/BI-04-C [Incorrect PDU Length, C-Frame, BR/EDR]	BR/EDR	0x0001	L2CAP_ECHO_REQ/RSP 4 5
L2CAP/COS/CED/BI-05-C [Incorrect PDU Length, C-Frame, LE Credit Based Connection Request]	LE	0x0005	L2CAP_LE_CREDIT_BASED_CONNECTION_REQ/RSP 13 14
L2CAP/COS/CED/BI-18-C [Incorrect PDU Length, C-Frame, LE Enhanced Credit Based Connection Request]	LE	0x0005	L2CAP_CREDIT_BASED_CONNECTION_REQ/RSP 13 14
L2CAP/COS/CED/BI-19-C [Incorrect PDU Length, C-Frame, LE Credit Based Connection Request Rejected]	LE	0x0005	L2CAP_LE_CREDIT_BASED_CONNECTION_REQ L2CAP_COMMAND_REJECT_RSP 7 8

Table 4.4: Incorrect PDU Length, C-Frame test cases

- Test Procedure

- The Lower Tester sends a C-frame to the IUT with LLID set to 0b10, PDU Length specified in [Table 4.4](#), and Channel ID set to the correct signaling channel for the logical link. The Information payload contains the packet payload request specified in [Table 4.4](#). For the ECHO request, the payload contains 1 octet of ECHO data.
- Perform alternative 2A, 2B, 2C, or 2D depending on the IUT's response.
 - Alternative 2A (IUT terminates the link):
 - 2A.1 The IUT terminates the link.
 - 2A.2 The test ends with a Pass verdict.
 - Alternative 2B (IUT discards the frame):
 - 2B.1 The IUT does not send a reply to the Lower Tester.
 - Alternative 2C (IUT rejects PDU):
 - 2C.1 The IUT sends an L2CAP_COMMAND_REJECT_RSP PDU to the Lower Tester.
 - Alternative 2D (Any other IUT response):
 - 2D.1 The Upper Tester issues a warning and the test ends.
- The Lower Tester sends a C-frame to the IUT with LLID set to 0b10 and PDU Length set to the payload length specified in [Table 4.4](#). The Information payload contains the payload length specified in [Table 4.4](#) octets of data containing the L2CAP payload. For the ECHO request, the payload contains 1 octet of ECHO data.
- The IUT sends the L2CAP response PDU specified in [Table 4.4](#) to the Lower Tester.

- Expected Outcome

Pass verdict

In Step 2A.1, the IUT terminates the link.

In Step 2B.1, the IUT does not send a reply to the Lower Tester.



In Step 2C.1, the IUT rejects the PDU.

In Step 2D.1, the IUT sends any valid response.

In Step 4, the IUT sends a response to the Upper Tester.

L2CAP/COS/CED/BI-06-C [Incorrect PDU Length, Received Data Packets with Continuation, Basic]

- Test Purpose

Verify that the IUT properly handles L2CAP Data PDUs that contain continuation packets that have an invalid PDU length.

- Reference

[1] 3.1, 4

- Initial Condition

- The Lower Tester uses version L2CAP Basic Mode.
- No security is used in this test case.
- The IUT is in the OPEN state with the BR/EDR transport for a data channel with assigned SCID and DCID. The IUT acts either as L2CAP initiator or as L2CAP acceptor.

- Test Procedure

1. The Lower Tester sends an L2CAP Data PDU to the IUT with LLID set to 0b10, PDU Length set to 11, and 4 octets of Information Payload Data that contains 4 octets of data.
2. The Lower Tester sends the continuation of the L2CAP Data PDU to the IUT with LLID set to 0b01 that contains 8 octets of data.
3. Perform alternative 3A, 3B, or 3C depending on the IUT's response.
 - Alternative 3A (IUT terminates the link):
 - 3A.1 The IUT terminates the link.
 - 3A.2 The test ends with a Pass verdict.
 - Alternative 3B (IUT discards the frame):
 - 3B.1 The IUT discards the frame.
 - 3B.2 The IUT does not send data to the Upper Tester.
 - Alternative 3C (Any other IUT response):
 - 3C.1 The Upper Tester issues a warning and the test ends.
4. The Lower Tester sends an L2CAP Data PDU to the IUT with LLID set to 0b01, PDU Length set to 12, and 8 octets of Information Payload Data that contains 8 octets of data.
5. The Lower Tester sends the continuation of the L2CAP Data PDU to the IUT with LLID set to 0b10 that contains 4 octets of data.
6. The IUT sends the data received in Steps 4 and 5 as one PDU to the Upper Tester.

- Test Condition

Reliability for the basic mode channel is not needed, so the first PDU in Step 1 can be silently discarded. The IUT can use a finite flush timeout or an ERTM channel.

- Expected Outcome

Pass verdict

In Step 3A.1, the IUT terminates the link.

In Step 3B.2, the IUT does not send the data from Step 1 to the Upper Tester.



In Step 3C.1, the IUT sends any valid response.

In Step 6, the IUT sends the data received in Steps 4 and 5 as one PDU to the Upper Tester.

L2CAP/COS/CED/BI-07-C [Incorrect PDU Length, Received Data Packets with Multiple Continuation]

- Test Purpose

Verify that the IUT properly handles L2CAP Data PDUs that contain multiple continuation packets that have an invalid PDU length.

- Reference

[1] 3.1, 4

- Initial Condition

- The Lower Tester uses version L2CAP Basic Mode.
- No security is used in this test case.
- The IUT is in the OPEN state with the BR/EDR transport for a data channel with assigned SCID and DCID. The IUT acts either as L2CAP initiator or as L2CAP acceptor.

- Test Procedure

1. The Lower Tester sends an L2CAP Data PDU to the IUT with LLID set to 0b10, PDU Length set to 4, and 4 octets of Information Payload Data that contains 4 octets of data.
2. The Lower Tester sends the continuation of the L2CAP Data PDU to the IUT with LLID set to 0b10 and 8 octets of Information Payload Data that contains 8 octets of data.
3. The IUT sends the data in Step 1 to the Upper Tester as one PDU.
4. Perform alternative 4A, 4B, or 4C depending on the IUT's response.
 - Alternative 4A (IUT terminates the link):
 - 4A.1 The IUT terminates the link.
 - 4A.2 The test ends with a Pass verdict.
 - Alternative 4B (IUT discards the frame):
 - 4B.1 The IUT discards the frame from Step 2.
 - 4B.2 The IUT does not send data to the Upper Tester.
 - Alternative 4C (Any other IUT response):
 - 4C.1 The Upper Tester issues a warning and the test ends.
5. The Lower Tester sends an L2CAP Data PDU to the IUT with LLID set to 0b10, PDU Length set to 12, and 4 octets of Information Payload Data that contains 4 octets of data.
6. The Lower Tester sends the continuation of the L2CAP Data PDU to the IUT with LLID set to 0b10 and 8 octets of Information Payload Data that contains 8 octets of data.
7. The Lower Tester sends the continuation of the L2CAP Data PDU to the IUT with LLID set to 0b10 and 8 octets of Information Payload Data that contains 8 octets of data.
8. The IUT sends the data in Steps 5 and 6 as one PDU to the Upper Tester.
9. Perform alternative 9A, 9B, or 9C depending on the IUT's response.
 - Alternative 9A (IUT terminates the link):
 - 9A.1 The IUT terminates the link.
 - 9A.2 The test ends with a Pass verdict.
 - Alternative 9B (IUT discards the frame):
 - 9B.1 The IUT discards the frame from Step 7.
 - 9B.2 The IUT does not send data to the Upper Tester.
 - Alternative 9C (Any other IUT response):
 - 9C.1 The Upper Tester issues a warning and the test ends.

10. The Lower Tester sends an L2CAP Data PDU to the IUT with LLID set to 0b10, PDU Length set to 4, and 4 octets of Information Payload Data that contains 4 octets of data.
11. The IUT sends the data in Step 10 to the Upper Tester as one PDU.

- Test Condition

Reliability for the basic mode channel is not needed, so the first PDU in Step 1 can be silently discarded. The IUT can use a finite flush timeout or an ERTM channel.

- Expected Outcome

Pass verdict

In Step 3, the IUT sends the data in Step 1 to the Upper Tester.

In Step 4A.1 or 9A.1, the IUT terminates the link.

In Step 4B.2 or 9B.2, the IUT does not send the data from Step 1 to the Upper Tester.

In Step 4C.1 or 9C.1, the IUT sends any valid response.

In Step 8, the IUT sends the data received in Steps 5 and 6 as one PDU to the Upper Tester.

In Step 11, the IUT sends the data in Step 10 to the Upper Tester.

4.4.1.2 Valid Signaling Command, Data Length > PDU Space

- Test Purpose

Verify that the IUT properly handles incorrect L2CAP signaling command packets with invalid Data length.

- Reference

[1] 3.1, 4

- Initial Condition

- The Lower Tester uses version L2CAP Basic Mode.
- No security is used in this test case.
- The L2CAP signaling channel specified in Table 4.5 is established between the IUT and the Lower Tester.
- The IUT is in CLOSED state and acts as an L2CAP acceptor.

- Test Case Configuration

Test Case	Transport	Signaling Channel	L2CAP payload/ PDU_Length/ Data Length
L2CAP/COS/CED/BI-08-C [Valid Signaling Command, Data Length > PDU Space, BR/EDR]	BR/EDR	0x0001	L2CAP_ECHO_REQ/RSP 7 4
L2CAP/COS/CED/BI-09-C [Valid Signaling Command, Data Length > PDU Space, LE Credit Based Connection Request]	LE	0x0005	L2CAP_LE_CREDIT_BASED_CONNECTION_REQ/RSP 14 11

Test Case	Transport	Signaling Channel	L2CAP payload/ PDU_Length/ Data Length
L2CAP/COS/CED/BI-20-C [Valid Signaling Command, Data Length > PDU Space, LE Enhanced Credit Based Connection Request]	LE	0x0005	L2CAP_CREDIT_BASED_CONNECTION_REQ/RSP 14 11
L2CAP/COS/CED/BI-21-C [Valid Signaling Command, Data Length > PDU Space, LE Credit Based Connection Request Rejected]	LE	0x0005	L2CAP_LE_CREDIT_BASED_CONNECTION_REQ L2CAP_COMMAND_REJECT_RSP 8 5

Table 4.5: Valid Signaling Command, Data Length > PDU Space test cases

- Test Procedure
 1. The Lower Tester sends a C-frame to the IUT with PDU Length set as specified in Table 4.5 and Channel ID set to the correct signaling channel for the logical link. The Information payload contains Data Length and L2CAP payload set as specified in Table 4.5. For the ECHO request, the payload contains 3 octets of ECHO data.
 2. Perform alternative 2A, 2B, 2C, or 2D depending on the IUT's response.
 - Alternative 2A (IUT terminates the link):
 - 2A.1 The IUT terminates the link.
 - 2A.2 The test ends with a Pass verdict.
 - Alternative 2B (IUT discards the frame):
 - 2B.1 The IUT does not send a reply to the Lower Tester.
 - Alternative 2C (IUT rejects PDU):
 - 2C.1 The IUT sends an L2CAP_COMMAND_REJECT_RSP PDU to the Lower Tester.
 - Alternative 2D (Any other IUT response):
 - 2D.1 The Upper Tester issues a warning and the test ends.
 3. The Lower Tester sends a C-frame to the IUT with PDU Length set as specified in Table 4.5 and Channel ID set to the correct signaling channel for the logical link. The Information payload contains the correct data length for the L2CAP payload specified in Table 4.5. For the ECHO request, the payload contains 3 octets of ECHO data.
 4. The IUT sends the L2CAP response PDU specified in Table 4.5 to the Lower Tester.
- Expected Outcome

Pass verdict

In Step 2A.1, the IUT terminates the link.

In Step 2B.1, the IUT does not send a reply to the Lower Tester.

In Step 2C.1, the IUT rejects the PDU.

In Step 2D.1, the IUT sends any valid response.

In Step 4, the IUT sends a response to the Lower Tester.

4.4.1.3 Incorrect Signaling Command Packets, Invalid Data Length for Command

- Test Purpose

Verify that the IUT properly handles incorrect L2CAP signaling command packets with invalid Data length.
- Reference

[1] 3.1, 4
- Initial Condition
 - The Lower Tester uses version L2CAP Basic Mode.
 - No security is used in this test case.
 - The L2CAP signaling channel specified in [Table 4.6](#) is established between the IUT and the Lower Tester.
 - The IUT is in CLOSED state and acts as an L2CAP acceptor.
- Test Case Configuration

Test Case	Transport	Signaling Channel	Execute Steps 3 and 4
L2CAP/COS/CED/BI-10-C [Incorrect Signaling Command Packets, Invalid Data Length for Command, BR/EDR]	BR/EDR	0x0001	Yes
L2CAP/COS/CED/BI-11-C [Incorrect Signaling Command Packets, Invalid Data Length for Command, LE]	LE	0x0005	No

Table 4.6: Incorrect Signaling Command Packets, Invalid Data Length for Command test cases

- Test Procedure
 1. The Lower Tester sends a C-frame to the IUT with PDU Length set to 9 and Channel ID set to the correct signaling channel for the logical link. The Information payload contains Data Length set to 5 with an L2CAP_DISCONNECTION_REQ packet followed by an octet with value 0x00.
 2. Perform alternatives 2A, 2B, 2C, or 2D depending on the IUT's response.
 - Alternative 2A (IUT terminates the link):
 - 2A.1 The IUT terminates the link.
 - 2A.2 The test ends with a Pass verdict.
 - Alternative 2B (IUT discards the frame):
 - 2B.1 The IUT does not send a reply to the Lower Tester.
 - Alternative 2C (IUT rejects PDU):
 - 2C.1 The IUT sends an L2CAP_COMMAND_REJECT_RSP PDU to the Lower Tester.
 - Alternative 2D (Any other IUT response):
 - 2D.1 The Upper Tester issues a warning and the test ends.

Execute Steps 3 and 4 if indicated in [Table 4.6](#).
 3. The Lower Tester sends a C-frame to the IUT with PDU Length set to 7 and Channel ID set to the correct signaling channel for the logical link. The Information payload contains Data Length set to 3 with an L2CAP_ECHO_REQ packet with 3 octets of echo data.
 4. The IUT sends an L2CAP_ECHO_RSP PDU to the Lower Tester.

- Expected Outcome

Pass verdict

In Step 2A.1, the IUT terminates the link.

In Step 2B.1, the IUT does not send a reply to the Lower Tester.

In Step 2C.1, the IUT rejects the PDU.

In Step 2D.1, the IUT sends any valid response.

In Step 4, the IUT sends a response to the Lower Tester.

L2CAP/COS/CED/BI-12-C [Valid Signaling Command, Shorter Data Length, Extra Zero Octet, BR/EDR]

- Test Purpose

Verify that the IUT properly handles invalid L2CAP signaling command packets with extra data in the Information Payload.

- Reference

[1] 3.1, 4

- Initial Condition

- The Lower Tester uses version L2CAP Basic Mode.
- No security is used in this test case.
- The BR/EDR L2CAP signaling channel 0x0001 is established between the IUT and the Lower Tester.
- The IUT is in CLOSED state and acts as an L2CAP acceptor.

- Test Procedure

1. The Lower Tester sends a C-frame to the IUT with PDU Length set to 9 and Channel ID set to the correct signaling channel for the logical link. The Information payload contains Data Length set to 4 with an L2CAP_ECHO_REQ packet with 4 octets of echo data followed by a 0 octet.
2. Perform alternative 2A or 2B depending on the IUT's response.
 - Alternative 2A (Send the echo response):
 - 2A.1 The IUT sends an L2CAP_ECHO_RSP PDU to the Lower Tester.
 - Alternative 2B (Disconnect):
 - 2B.1 The IUT terminates the link.
 - 2B.2 The test ends with a Pass verdict.
3. Perform alternative 3A, 3B, or 3C depending on the IUT's response.
 - Alternative 3A (Reject the signaling command):
 - 3A.1 The IUT sends an L2CAP_COMMAND_REJECT_RSP to the Lower Tester with Reason set to 0x0000.
 - Alternative 3B (Disconnect):
 - 3B.1 The IUT terminates the link.
 - Alternative 3C (Ignore the invalid command):
 - 3C.1 The IUT does not send a response to the Lower Tester.
 - 3C.2 The Lower Tester sends a C-frame to the IUT with PDU Length set to 8 and Channel ID set to the correct signaling channel for the logical link. The Information payload contains Data Length set to 4 with an L2CAP_ECHO_REQ packet with 4 octets of echo data.
 - 3C.3 The IUT sends an L2CAP_ECHO_RSP PDU to the Lower Tester.



- Expected Outcome

Pass verdict

In Step 2, the IUT responds to the L2CAP_ECHO_REQ from Step 1.

In Step 3A, the IUT rejects the command from Step 1.

In Step 2B or 3B, the IUT disconnects the link.

In Step 3C, the IUT ignores the invalid command and responds to the ECHO request.

4.4.1.4 Valid Signaling Command, Data Length > PDU Space

- Test Purpose

Verify that the IUT properly handles invalid L2CAP signaling command packets with extra data in the Information Payload.

- Reference

[1] 3.1, 4

- Initial Condition

- The Lower Tester uses version L2CAP Basic Mode.
- No security is used in this test case.
- The LE L2CAP signaling channel 0x0005 is established between the IUT and the Lower Tester.
- The IUT is in CLOSED state and acts as an L2CAP acceptor.

- Test Case Configuration

Test Case	Transport	Signaling Channel	L2CAP payload	Step 1 PDU Length / Data Length	Step 3 PDU Length / Data Length
L2CAP/COS/CED/BI-13-C [Valid Signaling Command, Shorter Data Length, Extra Zero Octet, LE Credit Based Connection Request]	LE	0x0005	L2CAP_LE_CREDIT_BASED_CONNECTION_REQ/RSP	15 10	14 10
L2CAP/COS/CED/BI-22-C [Valid Signaling Command, Shorter Data Length, Extra Zero Octet, LE Enhanced Credit Based Connection Request]	LE	0x0005	L2CAP_CREDIT_BASED_CONNECTION_REQ/RSP	15 10	14 10
L2CAP/COS/CED/BI-23-C [Valid Signaling Command, Shorter Data Length, Extra Zero Octet, LE Enhanced Credit Based Connection Request Rejected]	LE	0x0005	L2CAP_CREDIT_BASED_CONNECTION_REQ L2CAP_COMMAND_REJECT_RSP	9 4	8 4

Table 4.7: Valid Signaling Command, Data Length > PDU Space test cases

- Test Procedure
 1. The Lower Tester sends a C-frame to the IUT with PDU Length set as specified in [Table 4.7](#) and Channel ID set to the correct signaling channel for the logical link. The Information payload contains Data Length set as specified in [Table 4.7](#) with an L2CAP packet payload request as specified in [Table 4.7](#) with data length octets of connection data followed by a 0 octet.
 2. Perform alternative 2A, 2B, 2C, or 2D depending on the IUT's response.
 - Alternative 2A (IUT terminates the link):
 - 2A.1 The IUT terminates the link.
 - 2A.2 The test ends with a Pass verdict.
 - Alternative 2B (IUT discards the frame):
 - 2B.1 The IUT does not send a reply to the Lower Tester.
 - Alternative 2C (IUT rejects PDU):
 - 2C.1 The IUT sends an L2CAP_COMMAND_REJECT_RSP PDU to the Lower Tester.
 - Alternative 2D (Any other IUT response):
 - 2D.1 The Upper Tester issues a warning and the test ends.
 3. The Lower Tester sends a C-frame to the IUT with PDU Length set as specified in [Table 4.7](#) and Channel ID set to the correct signaling channel for the logical link. The Information payload contains an L2CAP packet payload request as specified in [Table 4.7](#) with Data Length set as specified in [Table 4.7](#) and with data length octets of connection request data.
 4. The IUT sends the L2CAP response PDU specified in [Table 4.7](#) to the Lower Tester. If that response is L2CAP_COMMAND_REJECT_RSP, the test ends with a Pass verdict.
 5. The Lower Tester sends an L2CAP_DISCONNECTION_REQ PDU to the IUT.
 6. The IUT sends an L2CAP_DISCONNECTION_RSP PDU to the Lower Tester.

- Expected Outcome

Pass verdict

In Step 2A.1, the IUT terminates the link.

In Step 2B.1, the IUT does not send a reply to the Lower Tester.

In Step 2C.1, the IUT rejects the PDU.

In Step 2D.1, the IUT sends any valid response.

In Step 4, the IUT sends a response to the connection request in Step 3.

4.4.1.5 Multiple Signaling Command in one PDU, Data Truncated, BR/EDR

- Test Purpose

Verify that the IUT properly handles invalid L2CAP signaling command packets with a Data Length of 0 in the Information Payload.

- Reference

[1] 3.1, 4

- Initial Condition

- The Lower Tester uses version L2CAP Basic Mode.
- No security is used in this test case.
- The BR/EDR L2CAP signaling channel 0x0001 is established between the IUT and the Lower Tester.
- The IUT is in CLOSED state and acts as an L2CAP acceptor.



- Test Case Configuration

Test Case	Second Command/Response	Second Command Data Length	PDU Length
L2CAP/COS/CED/BI-14-C [Multiple Signaling Command in one PDU, Data Truncated, BR/EDR, Echo Request]	L2CAP_ECHO_REQ L2CAP_ECHO_RSP	1	8
L2CAP/COS/CED/BI-15-C [Multiple Signaling Command in one PDU, Data Truncated, BR/EDR, Disconnection Request]	L2CAP_DISCONNECTION_REQ L2CAP_DISCONNECTION_RSP	0	8

Table 4.8: Multiple Signaling Command in one PDU, Data Truncated, BR/EDR test cases

- Test Procedure

- The Lower Tester sends a C-frame to the IUT with PDU Length as specified in [Table 4.8](#) and Channel ID set to the correct signaling channel for the logical link. The Information payload contains one L2CAP_ECHO_REQ packet with Data Length set to 0 with 0 octets of echo data and one command packet and Data Length set as specified in [Table 4.8](#).
- The IUT may send an L2CAP_ECHO_RSP PDU to the Lower Tester.
- Perform alternative 3A, 3B, 3C, or 3D depending on the IUT's response.
 - Alternative 3A (IUT terminates the link):
 - 3A.1 The IUT terminates the link.
 - 3A.2 The test ends with a Pass verdict.
 - Alternative 3B (IUT discards the frame):
 - 3B.1 The IUT does not send a reply to the Lower Tester.
 - Alternative 3C (IUT rejects PDU):
 - 3C.1 The IUT sends an L2CAP_COMMAND_REJECT_RSP PDU to the Lower Tester.
 - Alternative 3D (Any other IUT response):
 - 3D.1 The Upper Tester issues a warning and the test ends.
- The Lower Tester sends a C-frame to the IUT with PDU Length set to 4 and Channel ID set to the correct signaling channel for the logical link. The Information payload contains Data Length set to 0 with an L2CAP_ECHO_REQ packet with 0 octets of echo data.
- The IUT sends an L2CAP_ECHO_RSP PDU to the Lower Tester.

- Expected Outcome

Pass verdict

In Step 5, the IUT responds with an L2CAP_ECHO_RSP.

In Step 3A.1, the IUT terminates the link.

In Step 3B.1, the IUT does not send a reply to the Lower Tester.

In Step 3C.1, the IUT rejects the PDU.

In Step 3D.1, the IUT sends any valid response.

4.4.1.6 Multiple Signaling Command in one PDU, Data Truncated, LE

- Test Purpose

Verify that the IUT properly handles invalid L2CAP signaling command packets with an incorrect PDU length in the Information Payload.

- Reference

[1] 3.1, 4

- Initial Condition

- The Lower Tester uses version L2CAP Basic Mode.
- No security is used in this test case.
- The LE L2CAP signaling channel 0x0005 is established between the IUT and the Lower Tester.
- The IUT is in CLOSED state and acts as an L2CAP acceptor.

- Test Case Configuration

Test Case	PDU Length	First Command/Response	First Command Data Length	Second Command/Response	Second Command Data Length
L2CAP/COS/CED/BI-16-C [Multiple Signaling Command in one PDU, Data Truncated, LE Credit Based Flow Control Mode, LE Credit Based Connection Request]	28	L2CAP_LE_CREDIT_BASED_CONNECTION_REQ L2CAP_LE_CREDIT_BASED_CONNECTION_RSP	10	L2CAP_LE_CREDIT_BASED_CONNECTION_REQ L2CAP_LE_CREDIT_BASED_CONNECTION_RSP	11
L2CAP/COS/CED/BI-17-C [Multiple Signaling Command in one PDU, Data Truncated, LE Credit Based Flow Control Mode, Disconnection Request]	22	L2CAP_LE_CREDIT_BASED_CONNECTION_REQ L2CAP_LE_CREDIT_BASED_CONNECTION_RSP	10	L2CAP_DISCONNECTION_REQ L2CAP_DISCONNECTION_RSP	5
L2CAP/COS/CED/BI-24-C [Multiple Signaling Command in one PDU, LE, Data Truncated, Enhanced Credit Based Flow Control Mode, Enhanced Credit Based Connection Request]	28	L2CAP_CREDIT_BASED_CONNECTION_REQ L2CAP_CREDIT_BASED_CONNECTION_RSP	10	L2CAP_CREDIT_BASED_CONNECTION_REQ L2CAP_CREDIT_BASED_CONNECTION_RSP	11
L2CAP/COS/CED/BI-25-C [Multiple Signaling Command in one PDU, LE, Data Truncated, Enhanced Credit Based Flow Control Mode, Disconnection Request]	22	L2CAP_CREDIT_BASED_CONNECTION_REQ L2CAP_CREDIT_BASED_CONNECTION_RSP	10	L2CAP_DISCONNECTION_REQ L2CAP_DISCONNECTION_RSP	5

Table 4.9: Multiple Signaling Command in one PDU, Data Truncated, LE test cases



- Test Procedure
 1. The Lower Tester sends a C-frame to the IUT with PDU Length set as specified in [Table 4.9](#) and Channel ID set to the correct signaling channel for the logical link. The Information payload contains one first L2CAP command request packet, Data Length, and connection request data size as specified in [Table 4.9](#) and one second command request packet and Data Length set as specified in [Table 4.9](#) and the correct command data.
 2. Perform alternative 2A, 2B, 2C, or 2D depending on the IUT's response.
 - Alternative 2A (IUT terminates the link):
 - 2A.1 The IUT terminates the link.
 - 2A.2 The test ends with a Pass verdict.
 - Alternative 2B (IUT discards the frame):
 - 2B.1 The IUT does not send a reply to the Lower Tester.
 - Alternative 2C (IUT rejects PDU):
 - 2C.1 The IUT sends an L2CAP_COMMAND_REJECT_RSP PDU to the Lower Tester.
 - Alternative 2D (Any other IUT response):
 - 2D.1 The Upper Tester issues a warning and the test ends.
 3. The Lower Tester sends a C-frame to the IUT with PDU Length set to 14 and Channel ID set to the correct signaling channel for the logical link. The Information payload contains a first L2CAP command request packet, Data Length, and connection request data size as specified in [Table 4.9](#).
 4. The IUT sends the first L2CAP response PDU to the Lower Tester.
 5. The Lower Tester sends an L2CAP_DISCONNECTION_REQ PDU to the IUT.
 6. The IUT sends an L2CAP_DISCONNECTION_RSP PDU to the Lower Tester.

- Expected Outcome

Pass verdict

In Step 2A.1, the IUT terminates the link.

In Step 2B.1, the IUT does not send a reply to the Lower Tester.

In Step 2C.1, the IUT rejects the PDU.

In Step 2D.1, the IUT sends any valid response.

In Step 4, the IUT sends a response to the connection request in Step 4.

4.4.1.7 Ignore Command Response with Invalid ID or Duplicate Response

- Test Purpose

Verify that the IUT ignores a Command Response with an Invalid ID and a duplicate response. The Invalid ID can be an ID of 0. The test also verifies that identifiers are not duplicated until all valid identifiers have been used.

- Reference

[1] 4

- Initial Condition

- The IUT is in CLOSED state for data channel. No ACL link is established.
- No security is used in this test case.
- The L2CAP signaling channel specified in [Table 4.10](#) is established between the IUT and the Lower Tester.
- The IUT is in CLOSED state and acts as an L2CAP acceptor.



- Test Case Configuration

Test Case	Transport	Signaling Channel	L2CAP Signaling Packet
L2CAP/COS/CED/BI-28-C [Ignore Command Response with Invalid ID or Duplicate Response, BR/EDR]	BR/EDR	0x0001	L2CAP_CONNECTION_REQ/RSP
L2CAP/COS/CED/BI-29-C [Ignore Command Response with Invalid ID or Duplicate Response, LE]	LE	0x0005	L2CAP_LE_CREDIT_BASED_CONNECTION_REQ/RSP

Table 4.10: Ignore Command Response with Invalid ID or Duplicate Response test cases

- Test Procedure

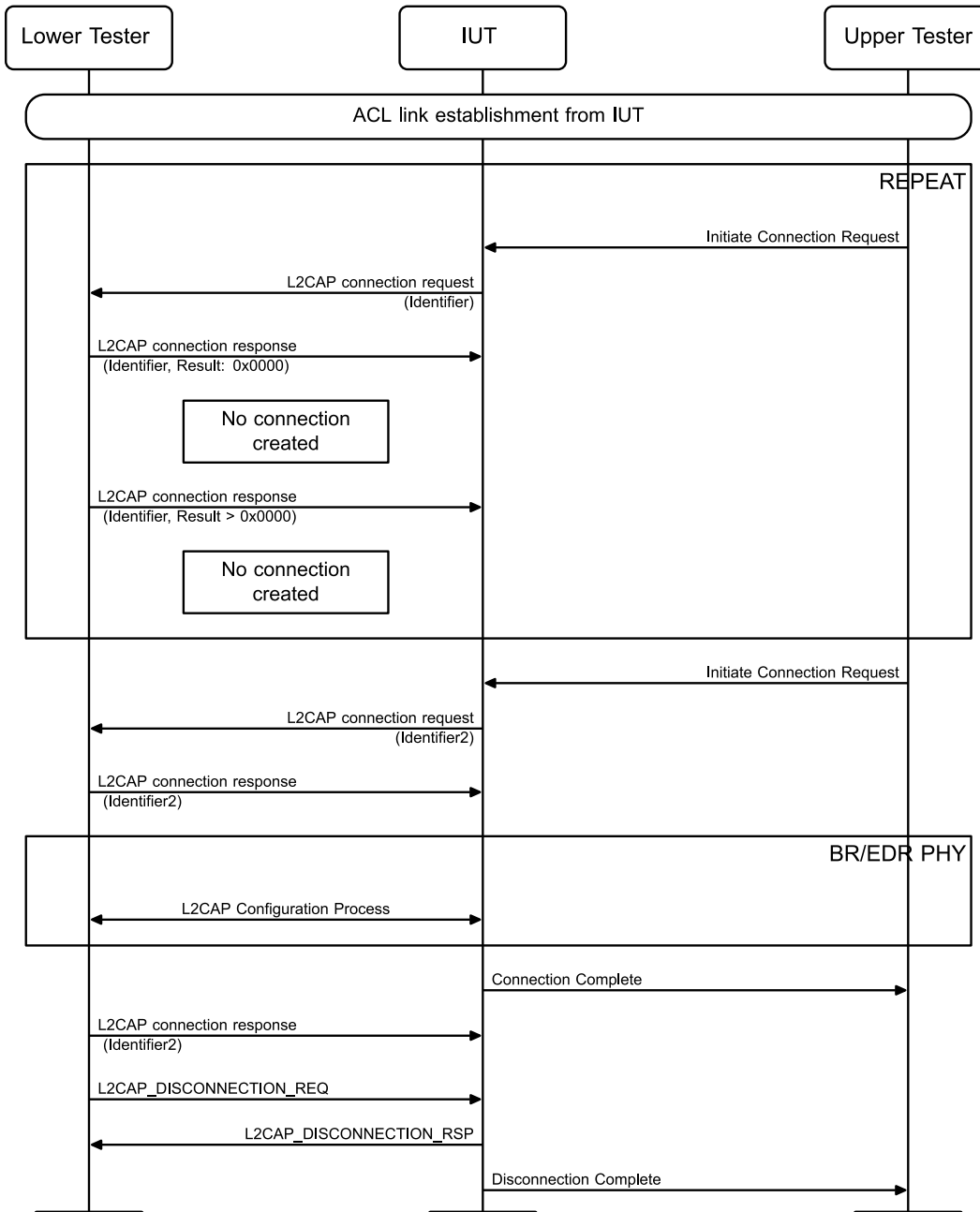

Figure 4.11: Ignore Command Response with Invalid ID or Duplicate Response MSC

1. The Upper Tester commands the IUT to start the procedure that initiates the connection request specified in [Table 4.10](#).
2. The IUT sends an L2CAP request PDU specified in [Table 4.10](#) to the Lower Tester with an Identifier. The Lower Tester saves the Identifier.
3. The Lower Tester sends a successful L2CAP response PDU specified in [Table 4.10](#) to the IUT with the Identifier set to 0. The IUT and the Lower Tester do not make a connection.
4. The Lower Tester sends an unsuccessful L2CAP response PDU specified in [Table 4.10](#) to the IUT with the identifier from Step 2, and a non-zero Result. The IUT and the Lower Tester do not make a connection.

5. Repeat Steps 1–4 with the Identifier in Step 3 set to any non-zero value other than the two values saved in Step 2.
6. Repeat Steps 1–4 253 times with the Identifier in Step 3 set to 0x00. The test fails if the IUT reuses an Identifier that already was used.
7. The Upper Tester commands the IUT to start the procedure that initiates the connection request specified in [Table 4.10](#).
8. The IUT sends an L2CAP request PDU specified in [Table 4.10](#) to the Lower Tester with an Identifier.
9. The Lower Tester sends a successful L2CAP response PDU specified in [Table 4.10](#) to the IUT with the Identifier set to the value in Step 8.
10. If the Transport is BR/EDR, the Lower Tester and the IUT may execute the L2CAP Configuration Process.
11. The IUT sends a connection complete event to the Upper Tester.
12. The Lower Tester sends the same L2CAP response PDU as was sent in Step 9.
13. If the IUT sends a connection complete event to the Upper Tester, the test ends with a Fail verdict.
14. The Lower Tester sends an L2CAP_DISCONNECTION_REQ PDU to the IUT.
15. The IUT sends an L2CAP_DISCONNECTION_RSP PDU to the Lower Tester.

- Expected Outcome

Pass verdict

In Step 4, the IUT and the Lower Tester do not make a connection.

In Step 15, the IUT sends an L2CAP_DISCONNECTION_RSP PDU.

Fail verdict

The IUT reuses an Identifier in Step 2 in the first 255 repeats.

In Step 13, the IUT sends a connection complete event.

4.4.2 Encryption Key Size

Tests for insufficient encryption key size require an encrypted link with a key size less than the size required by an L2CAP channel. The encryption key size requirements of attributes are determined by the associated profile.

Preamble procedure:

Establish an encrypted link over the LE transport between the IUT and the Lower Tester. For example, see test SM/CEN/EKS/BV-01-C or SM/PER/EKS/BV-02-C in [\[16\]](#) for LE transport, or LMP/ENC/BV-01-C or LMP/ENC/BV-05-C in [\[17\]](#) for BR/EDR transport. The key size is less than the size required by the security requirements of the L2CAP channel.

4.4.3 Configuration of Data Channel CFD

Verify the procedures for configuration of a data channel.

L2CAP/COS/CFD/BV-01-C [Continuation Flag]

- Test Purpose

Verify that the IUT can receive configuration requests that have the continuation flag set.

- Reference

[\[1\]](#) Table 6.1, 4.4, 4.5, 5



- Initial Condition
 - The IUT is in CONFIG state for a data channel with assigned CID. The IUT's request path is already configured. The connection was initiated from the Lower Tester.
- Test Procedure

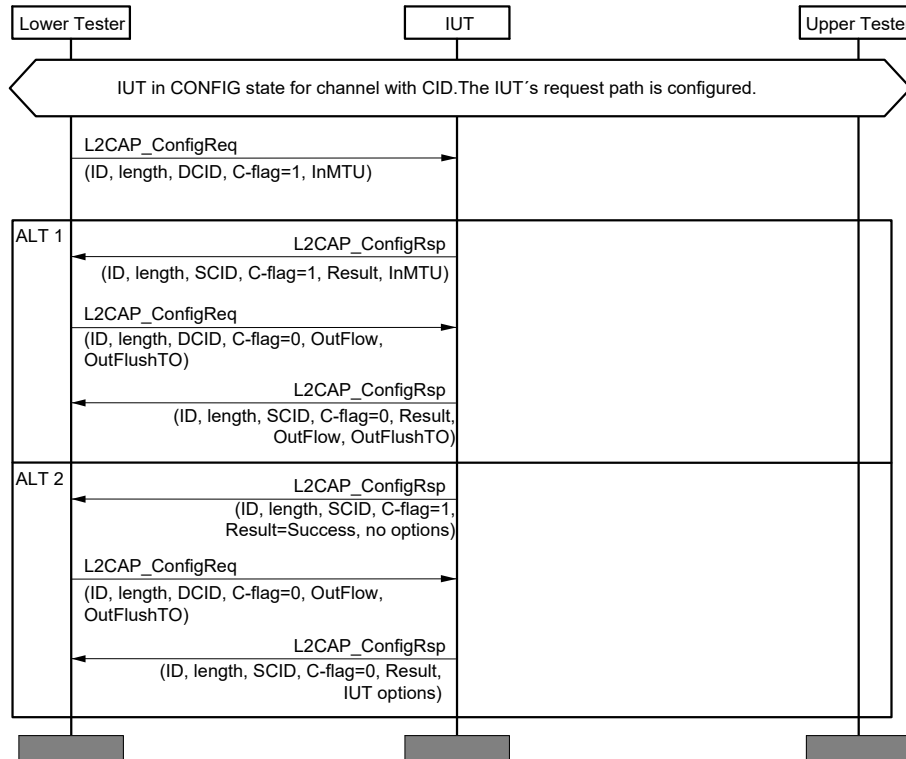

Figure 4.12: L2CAP/COS/CFD/BV-01-C [Continuation Flag] MSC

- Test Condition

Acceptable configuration parameter values are supplied by the manufacturer.
- Expected Outcome

Pass verdict

The IUT responds to each L2CAP_CONFIGURATION_REQ message with an L2CAP_CONFIGURATION_RSP message indicating "success". The response to the first message has the continuation flag set. The final response has the continuation flag cleared. One of the two responses indicates an MTU size equal to that in the request.

- Notes

The Lower Tester sets the most significant bit of the type parameter to '1', indicating a "hint", for the optional parameters Quality of Service, and Retransmission and Flow Control. If the IUT supports the optional parameter, it accepts the default value; if it does not support an optional parameter, it should ignore the hint and take no additional action.

L2CAP/COS/CFD/BV-02-C [Negotiation with Reject]

- Test Purpose

Verify that the IUT can perform negotiation while the Lower Tester rejects the proposed configuration parameter values.
- Reference

[1] Table 6.1, 4.4, 4.5
- Initial Condition
 - The Lower Tester utilizes version L2CAP Basic Mode.
 - The IUT is in CONFIG state for a data channel with assigned CID. The IUT acts either as L2CAP initiator or as L2CAP acceptor.
- Test Procedure

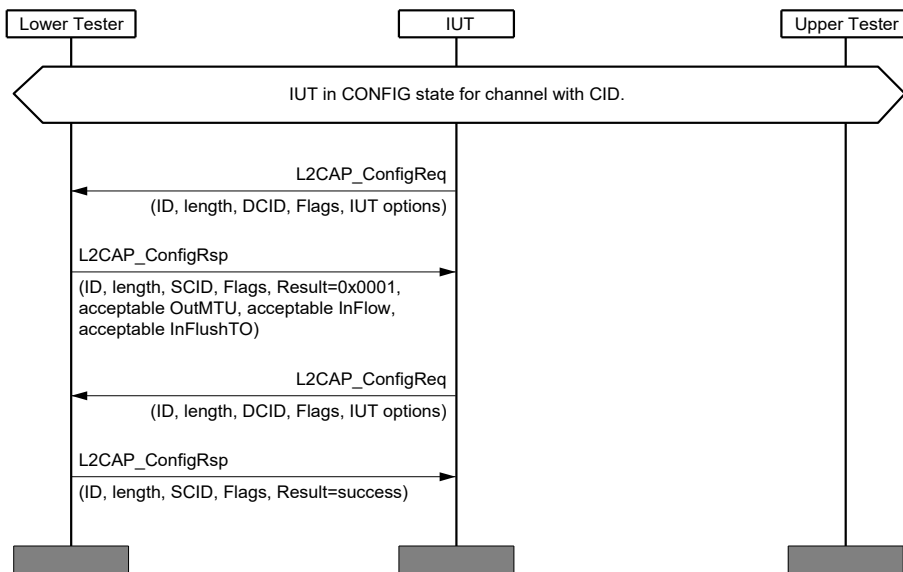

Figure 4.13: L2CAP/COS/CFD/BV-02-C [Negotiation with Reject] MSC

- Test Condition

Acceptable configuration parameter values have to be stated by the manufacturer.
- Expected Outcome

Pass verdict

The IUT sends an L2CAP_CONFIGURATION_REQ with acceptable values received in the L2CAP_CONFIGURATION_RSP with Result= Failure – unacceptable parameters or the L2CAP_CONFIGURATION_REQ contains no options.

or

The IUT closes the channel.

L2CAP/COS/CFD/BV-03-C [Send Requested Options]

- Test Purpose

Verify that the IUT can receive a configuration request with no options and send the requested options to the Lower Tester.
- Reference

[1] Table 6.1, 4.4, 4.5
- Initial Condition
 - The Lower Tester utilizes version L2CAP Basic Mode.
 - The IUT is in CONFIG state for data channel with assigned CID. The IUT acts either as L2CAP initiator or as L2CAP acceptor.
- Test Procedure

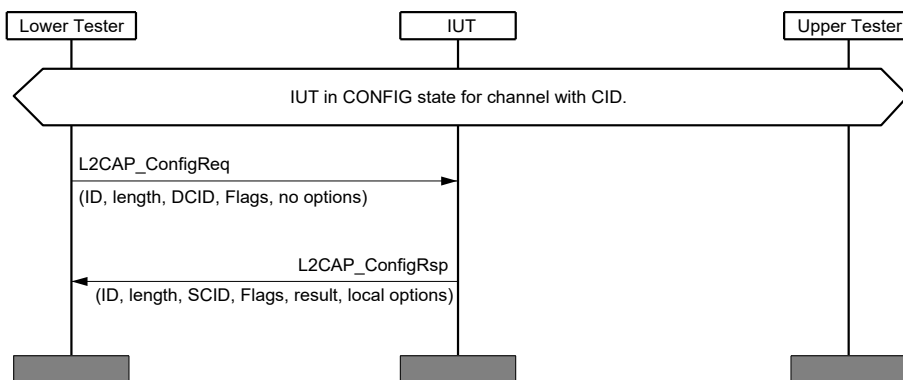

Figure 4.14: L2CAP/COS/CFD/BV-03-C [Send Requested Options] MSC

- Expected Outcome

Pass verdict

The IUT sends an L2CAP_CONFIGURATION_RSP before expiration of RTX timer.
- Notes

The Lower Tester uses TSPX_timer_rtx_max for RTX timer.

L2CAP/COS/CFD/BV-08-C [Non-blocking Config Response]

- Test Purpose

Verify that the IUT does not block transmitting L2CAP_CONFIGURATION_RSP while waiting for L2CAP_CONFIGURATION_RSP from the Lower Tester.
- Reference

[1] 4.4, 4.5
- Initial Condition
 - The Lower Tester utilizes version L2CAP Basic Mode.
 - The IUT is in CONFIG state for a channel with CID. The IUT acts as L2CAP initiator.

- Test Procedure

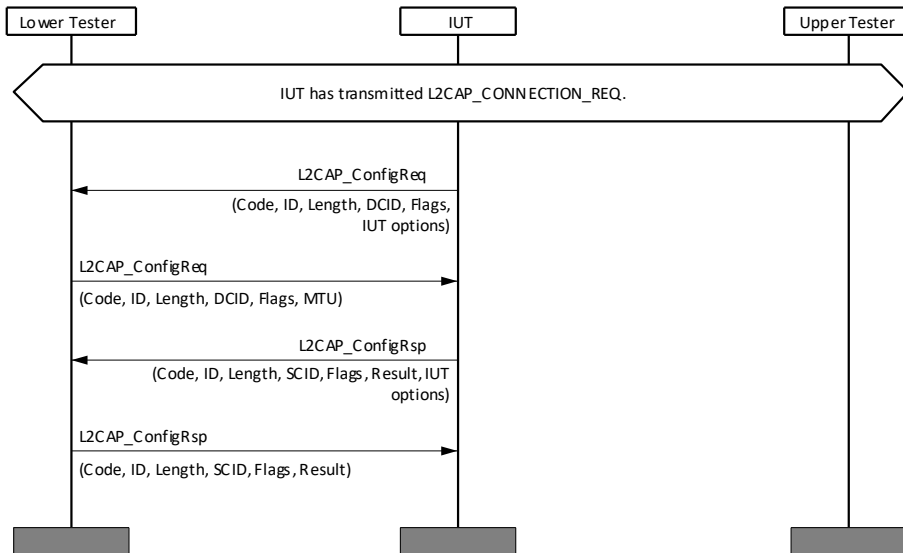

Figure 4.15: L2CAP/COS/CFD/BV-08-C [Non-blocking Config Response] MSC

- Expected Outcome

Pass verdict

After receiving L2CAP_CONFIGURATION_REQ from the Lower Tester, the IUT transmits L2CAP_CONFIGURATION_RSP to the Lower Tester.

- Notes

The Lower Tester uses an MTU value not exceeding what is transmitted from the IUT in the L2CAP_CONFIGURATION_REQ. Other options have default or accepted values, and hence, need not be transmitted. It is implementation dependent which options are transmitted by the IUT.

L2CAP/COS/CFD/BV-09-C [Mandatory 48 Byte MTU]

- Test Purpose

Verify that the IUT can support mandatory 48 byte MTU.

- Reference

[1] 5.1, 7.1

- Initial Condition

- The IUT is in CONFIG state for a channel with CID.
- The IUT acts as L2CAP initiator.

• Test Procedure

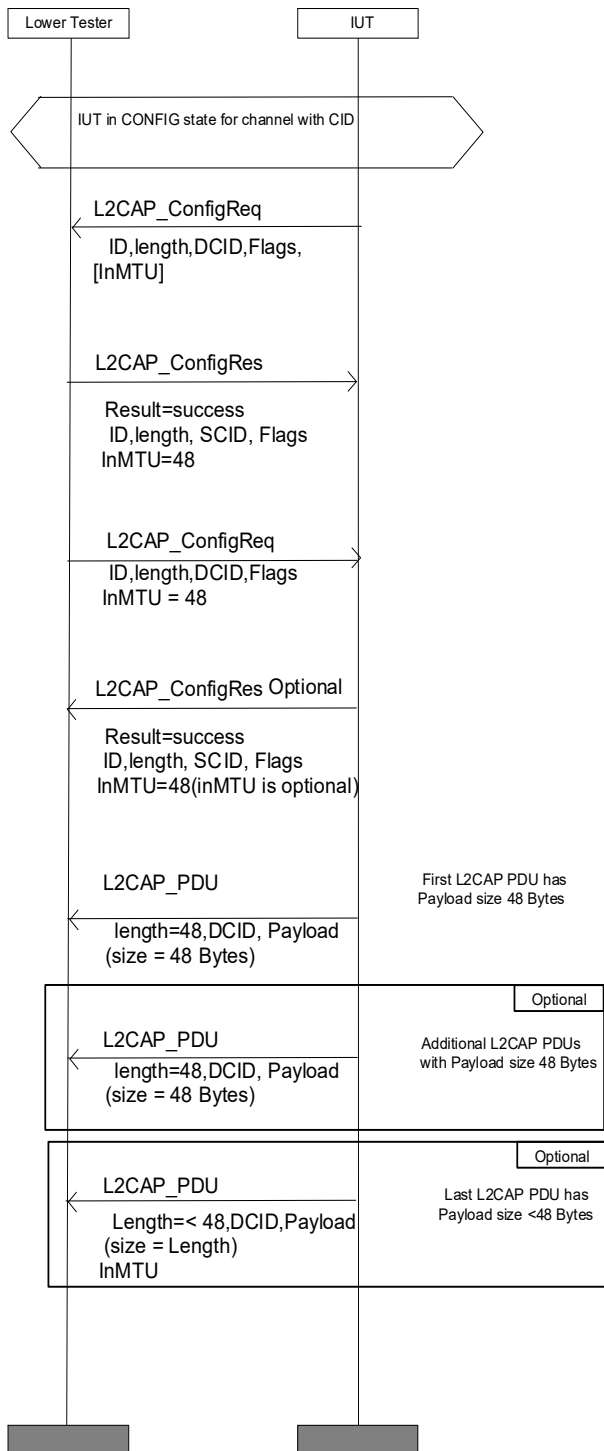

Figure 4.16: L2CAP/COS/CFD/BV-09-C [Mandatory 48 Byte MTU] MSC

• Expected Outcome

Pass verdict

The IUT transmits a configuration request containing InMTU or omit the InMTU. Regardless of indicated MTU, when the Lower Tester responds with MTU=48 the configuration completes successfully without further negotiation.



The IUT responds with MTU=48 or omit the MTU in its configuration response. The configuration completes successfully without further negotiation.

- Notes

In part 1, the IUT may request any MTU > 48.

L2CAP/COS/CFD/BV-10-C [Retransmission Mode Negotiation]

- Test Purpose

Verify that the IUT can negotiate L2CAP F+E for Retransmission mode.

- Reference

[1] 5.3, 7.4

- Initial Condition

- The IUT is in CONFIG state for a data channel with assigned CID.

- Test Procedure

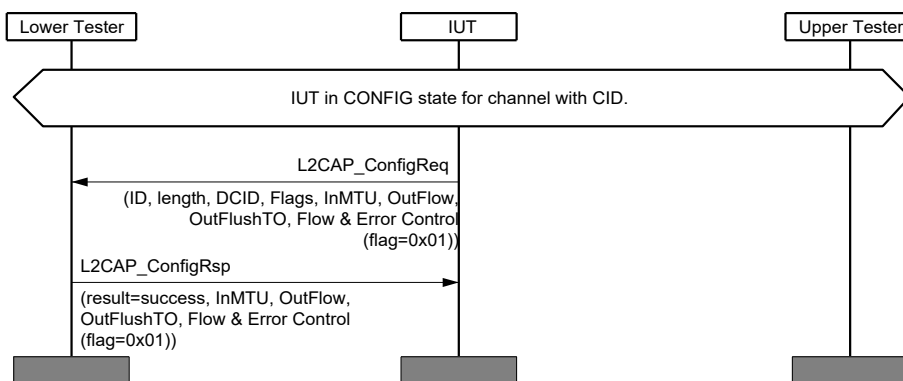

Figure 4.17: L2CAP/COS/CFD/BV-10-C [Retransmission Mode Negotiation] MSC

- Expected Outcome

Pass verdict

The IUT sends an L2CAP_CONFIGURATION_REQ with L2CAP Flow and Error control option for Retransmission mode.

L2CAP/COS/CFD/BV-11-C [Negotiation of Unsupported Parameter]

- Test Purpose

Verify that the IUT can negotiate when the Lower Tester proposes an unsupported configuration parameter value.

- Reference

[1] 4.4, 4.5

- Initial Condition

- The Lower Tester performs an Information Request/Response command to read the supported mode of the IUT.
- The Lower Tester then sends a Configuration Request with unsupported configuration parameters to the IUT.

- Test Procedure

The Lower Tester proposes configuration parameter values the IUT does not support.

The IUT acts either as L2CAP initiator or as L2CAP acceptor.

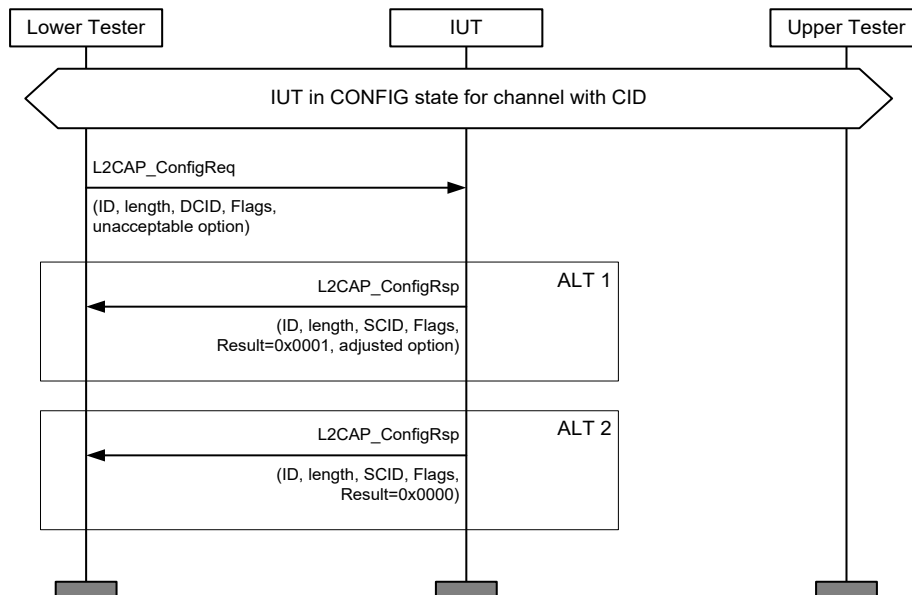

Figure 4.18: L2CAP/COS/CFD/BV-11-C [Negotiation of Unsupported Parameter] MSC

- Expected Outcome

Pass verdict

The IUT negotiates the configuration parameters to supported values (ALT 1). If NO unacceptable options are possible, the IUT may respond as shown in ALT 2.

L2CAP/COS/CFD/BV-12-C [Unknown Option Response]

- Test Purpose

Verify that the IUT can give the appropriate error code when the Lower Tester proposes any number of unknown options that are optional.

- Reference

[1] 4.4, 4.5

- Initial Condition

- The IUT is in CONFIG state. Supported configuration option types are given as the TSPX_supported_config_options IXIT value.
- The IUT either acts as L2CAP initiator or as L2CAP acceptor.

- Test Procedure

Repeat the steps for each round in [Table 4.11](#).

The Lower Tester transmits a configuration request with a number of options as specified in [Table 4.11](#) where the option types are not supported by the IUT and all have the MSB set to 1.

Round	Number of Options
1	1
2	2
3	3
4	4
5	5
6	6
7	7
8	8
9	9
10	10

Table 4.11: L2CAP/COS/CFD/BV-12-C [Unknown Option Response] rounds

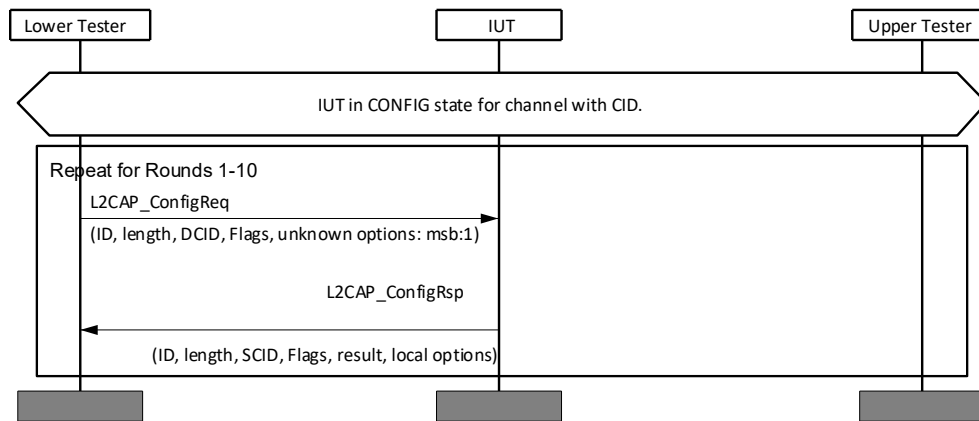

Figure 4.19: L2CAP/COS/CFD/BV-12-C [Unknown Option Response] MSC

- Expected Outcome

Pass verdict

The IUT transmits L2CAP_CONFIGURATION_RSP before expiration of RTX timer.

L2CAP/COS/CFD/BV-13-C [Flow Control Mode Negotiation]

- Test Purpose

Verify that the IUT can negotiate L2CAP F+E for Flow Control only mode.

- Reference

[1] 5.4, 7.4

- Initial Condition

- The IUT is in CONFIG state for a data channel with assigned CID.

- Test Procedure

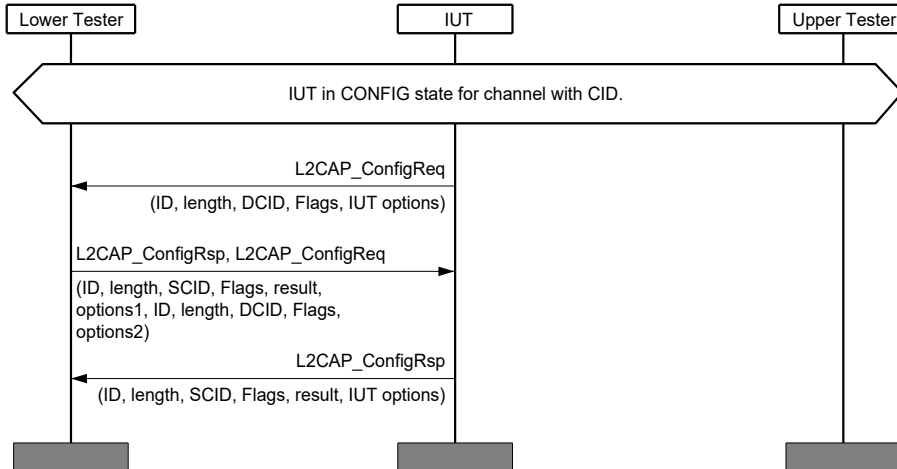

Figure 4.20: L2CAP/COS/CFD/BV-13-C [Flow Control Mode Negotiation] MSC

- Expected Outcome

Pass verdict

The IUT sends an L2CAP_CONFIGURATION_REQ with L2CAP Flow and Error control option for Flow Control only mode.

L2CAP/COS/CFD/BV-14-C [Unknown Mandatory Options Request]

- Test Purpose

Verify that the IUT can give the appropriate error code when the Lower Tester proposes any number of unknown options where at least one is mandatory.

- Reference

[1] 4.4, 4.5

- Initial Condition

- The IUT is in CONFIG state. Supported configuration option types are given as the TSPX_supported_config_options IXIT value.
- The IUT acts either as L2CAP initiator or as L2CAP acceptor.

- Test Procedure

The Lower Tester transmits a configuration request with a number of options as specified in Table 4.12 where the option types are not supported by the IUT and have the MSBs set as specified in Table 4.12.

Round	Number of Options	MSB value
1	1	All set to 0
2	2	All set to 1, except the last one set to 0
3	3	All set to 0
4	4	Two at random set to 0, the rest set to 1
5	5	All set to 1, except the last one set to 0
6	6	Two at random set to 0, the rest set to 1

Round	Number of Options	MSB value
7	7	All set to 0
8	8	All set to 1, except the last one set to 0
9	9	Two at random set to 0, the rest set to 1
10	10	All set to 1, except the last one set to 0

Table 4.12: L2CAP/COS/CFD/BV-14-C [Unknown Mandatory Options Request] rounds

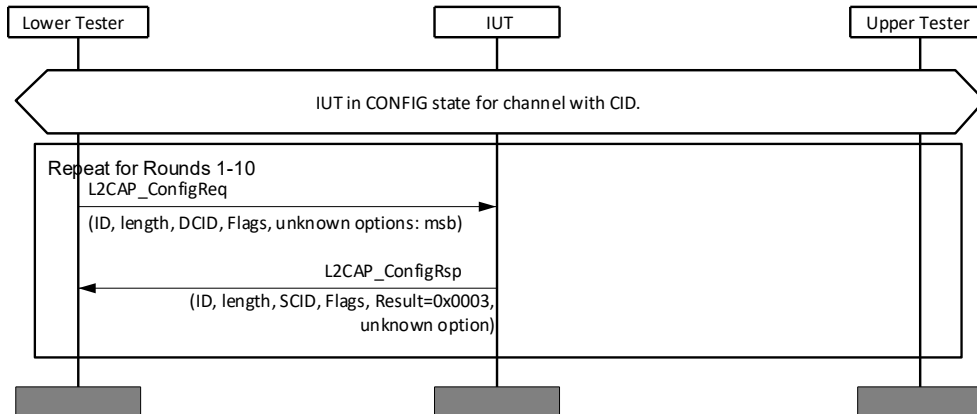

Figure 4.21: L2CAP/COS/CFD/BV-14-C [Unknown Mandatory Options Request] MSC

- Expected Outcome

Pass verdict

The IUT transmits an L2CAP_CONFIGURATION_RSP with Result=0x0003 and specifying one of the unsupported options that has the MSB set to 0.

4.4.4 Implementation-Specific Information Exchange IEX

Verify the implementation-specific information exchange feature.

L2CAP/COS/IEX/BV-01-C [Query for 1.2 Features]

- Test Purpose

Verify that the IUT transmits an information request command to solicit if the remote device supports Specification 1.2 features.

- Reference

[1] 4.10, 4.11

- Initial Condition

- The IUT is in any state.

- Test Procedure

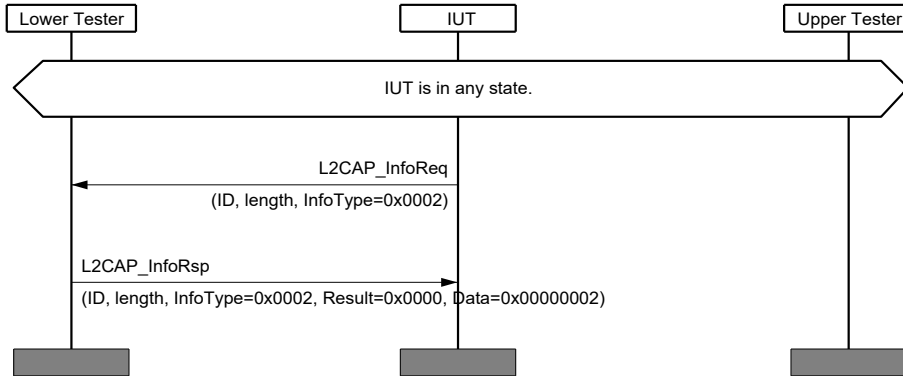

Figure 4.22: L2CAP/COS/IEX/BV-01-C [Query for 1.2 Features] MSC

- Expected Outcome

Pass verdict

The IUT transmits L2CAP_INFORMATION_REQ with InfoType=0x0002.

L2CAP/COS/IEX/BV-02-C [Respond with 1.2 Features]

- Test Purpose

Verify that the IUT responds to an information request command soliciting for Specification 1.2 features.

- Reference

[1] 4.10, 4.11, 4.12

- Initial Condition

- The IUT is in any state.

- Test Procedure

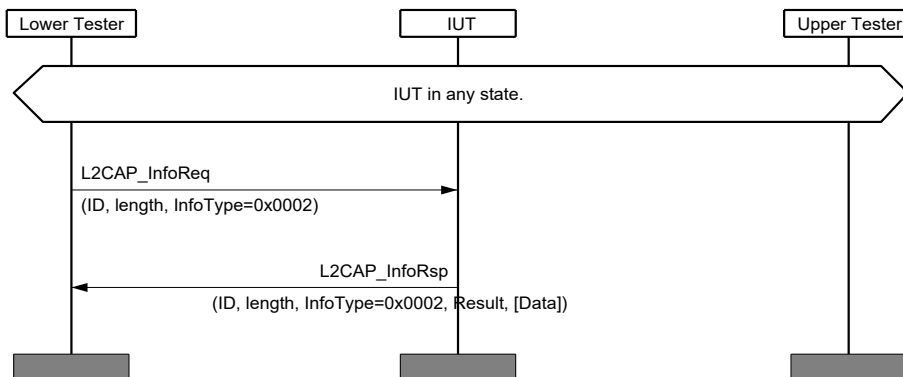

Figure 4.23: L2CAP/COS/IEX/BV-02-C [Respond with 1.2 Features] MSC

- Expected Outcome

Pass verdict

The IUT transmits L2CAP_INFORMATION_RSP with InfoType=0x0002.

If the IUT supports any extended features:

The Result=Success and Data is formatted correctly for an Extended Feature Mask.

Otherwise:

The Result=Success, and Data is set to 0x0000 0000, OR

The Result=Not Supported, and Data is not present.

L2CAP/COS/IEX/BI-01-C [Accept Reject of Information Request, Peer Older Than v3.0]

- Test Purpose

Verify that the IUT transmits an information request command to solicit if the remote device supports Specification 1.2 features.
- Reference

[1] 4.11
- Initial Condition
 - The IUT is in any state.
 - The Lower Tester is configured to support Core v2.1.

• Test Procedure

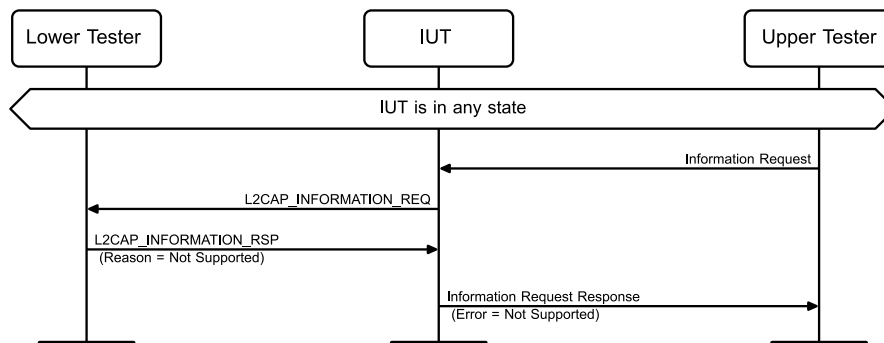

Figure 4.24: L2CAP/COS/IEX/BI-01-C [Accept Reject of Information Request, Peer Older Than v3.0] MSC

1. The Upper Tester commands the IUT to send an information request.
2. The IUT sends an L2CAP_INFORMATION_REQ PDU to the Lower Tester.
3. The Lower Tester sends an L2CAP_INFORMATION_RSP PDU to the IUT with Result set to “Not Supported”.
4. The IUT sends an Information Request Response to the Upper Tester with a “Not Supported” error.

• Expected Outcome

Pass verdict

In Step 4, the IUT sends a “Not Supported” error.

4.4.5 Echo Handling ECH

Verify the procedures for echo handling, which means link testing and passing of vendor-specific information with the ECHO_REQUEST and ECHO_RESPONSE signaling command.

L2CAP/COS/ECH/BV-01-C [Respond to Echo Request]

- Test Purpose

Verify that the IUT responds to an echo request.
- Reference

[1] Table 6.1, 4.8, 4.9
- Initial Condition
 - The Lower Tester utilizes version L2CAP Basic Mode.
 - The IUT is in CLOSED state for data channel. No ACL link is established. The IUT acts as L2CAP acceptor.
- Test Procedure

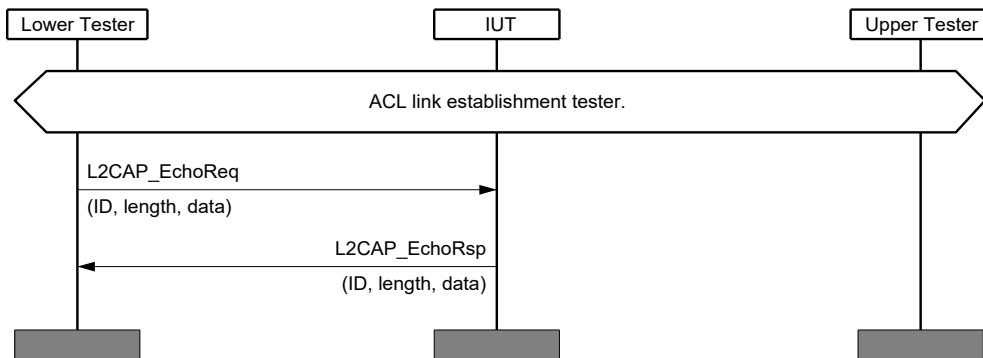

Figure 4.25: L2CAP/COS/ECH/BV-01-C [Respond to Echo Request] MSC

- Expected Outcome

Pass verdict

The IUT sends an L2CAP_ECHO_RSP before expiration of RTX timer.
- Notes

The Lower Tester uses maximum value for RTX timer.

L2CAP/COS/ECH/BV-02-C [Send Echo Request]

- Test Purpose

Verify that the IUT sends an echo request.
- Reference

[1] Table 6.1, 4.8, 4.9

- Initial Condition
 - The Lower Tester utilizes version L2CAP Basic Mode.
 - The IUT is in CLOSED state for data channel. No ACL link is established. The IUT acts as L2CAP initiator.

- Test Procedure

ACL link establishment is part of the test case.

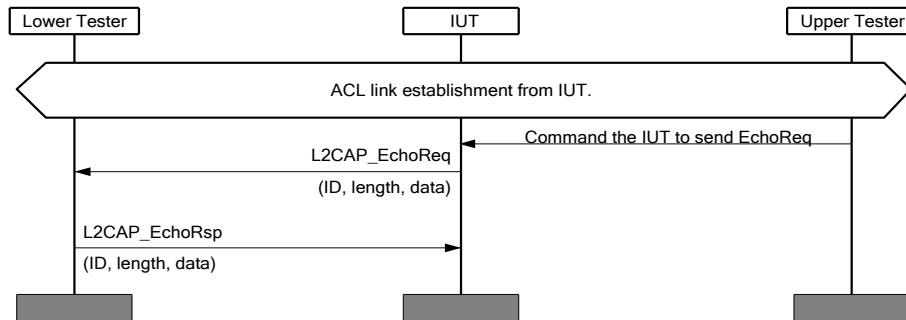

Figure 4.26: L2CAP/COS/ECH/BV-02-C [Send Echo Request] MSC

- Test Condition
 - It must be possible to send an echo request from the Upper Tester to the Lower Tester.

- Expected Outcome

Pass verdict

The IUT sends an L2CAP_ECHO_REQ.

4.4.6 LE Credit Based Flow Control Mode

Verify the correct implementation of the data channel in LE Credit Based Flow Control mode.

L2CAP/COS/CFC/BV-01-C [Segmentation]

- Test Purpose
 - Verify that the IUT can send data segments that are larger than the K-frame payload size.
- Reference
 - [12] 3.4
- Initial Condition
 - The appropriate signaling channel for the transport is used.
 - An LE Data Channel is established on the SPSM declared via the TSPX_spsm IXIT value with credits returned to the IUT by the Lower Tester.
 - The role of the IUT is indicated via TSPX_iut_role_initiator.
 - The MTU and MPS of the Lower Tester are indicated in the TSPX_tester_mtu and TSPX_tester_mps IXIT values.
 - The Upper Tester can command the IUT to send data.

- Test Procedure

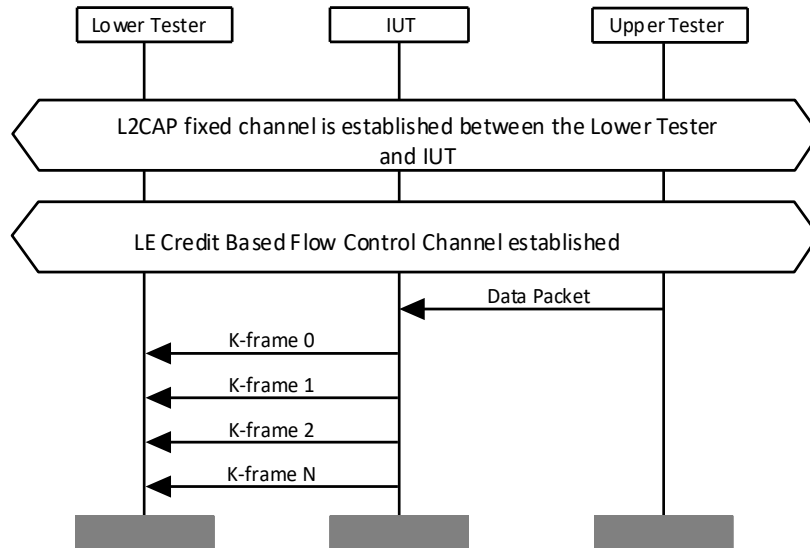

Figure 4.27: L2CAP/COS/CFC/BV-01-C [Segmentation] MSC

The Upper Tester sends a data packet to the IUT which is larger than or equal to the Lower Tester’s MPS and smaller than or equal to the Lower Tester’s MTU.

- Expected Outcome

Pass verdict

The IUT sends at least one K-frame containing data to the Lower Tester.

If the Upper Test sends a data packet to the IUT which is larger than the Lower Tester’s MPS and smaller than the Lower Tester’s MTU, the IUT segments the K-frames correctly.

The data sent by the IUT to the Lower Tester matches the data sent to the IUT by the Upper Tester.

L2CAP/COS/CFC/BV-02-C [No Segmentation]

- Test Purpose

Verify that the IUT can send data segments that do not require segmentation.

- Reference

[12] 3.4

- Initial Condition

- The appropriate signaling channel for the transport is used.
- An LE Data Channel is established on the SPSM declared via the TSPX_spsm IXIT value with credits returned to the IUT by the Lower Tester.
- The role of the IUT is indicated in the TSPX_iut_role_initiator IXIT value.

- Test Procedure

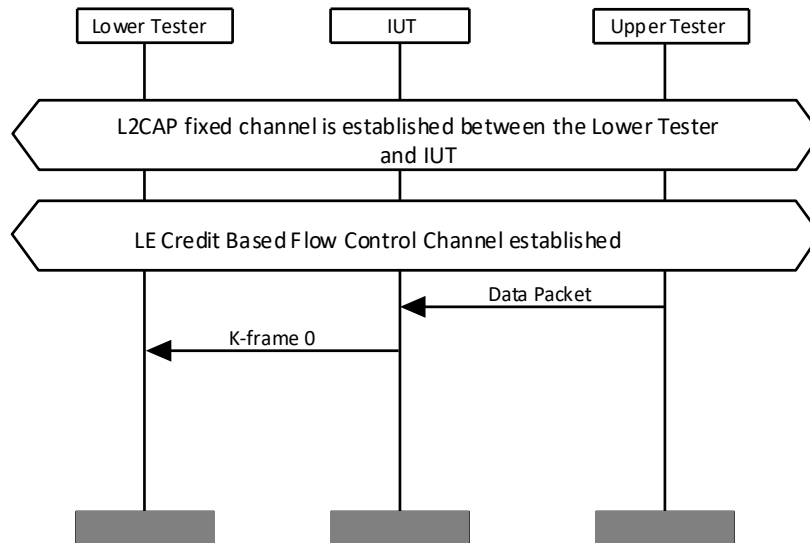

Figure 4.28: L2CAP/COS/CFC/BV-02-C [No Segmentation] MSC

The Upper Tester sends a data packet of one octet to the IUT.

- Expected Outcome

Pass verdict

The IUT send a K-frame containing the data to the Lower Tester.

The data sent by the IUT to the Lower Tester matches the data sent to the IUT by the Upper Tester.

L2CAP/COS/CFC/BV-03-C [Reassembling]

- Test Purpose

Verify that the IUT can correctly reassemble data received from the Lower Tester where the L2CAP SDU Length is greater than the IUT K-frame payload size.

- Reference

[12] 3.4

- Initial Condition

- The appropriate signaling channel for the transport is used.
- An LE Data Channel is established on the SPSM declared via the TSPX_spsm IXIT value.
- The role of the IUT is indicated in the TSPX_iut_role_initiator IXIT value.

- Test Procedure

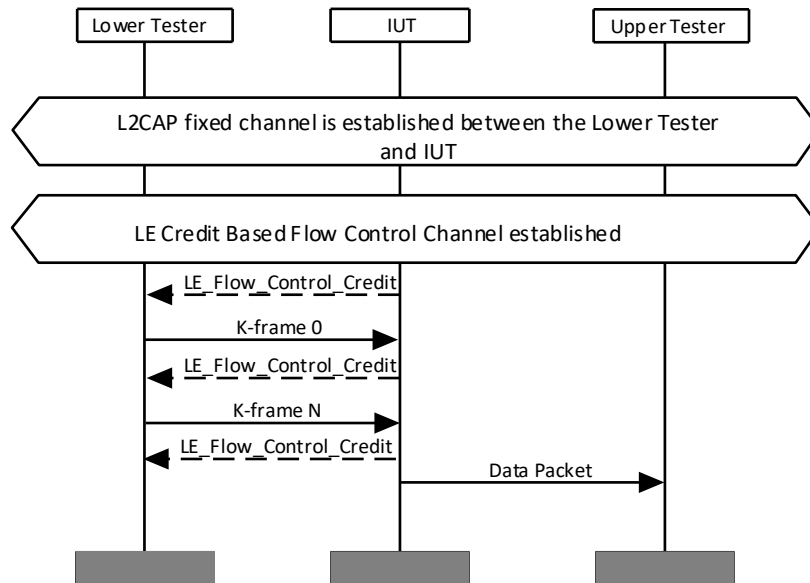

Figure 4.29: L2CAP/COS/CFC/BV-03-C [Reassembling] MSC

(Optional) If the channel was created with zero credits, the Upper Tester issues a command to the IUT to send credits.

The Lower Tester sends data in a series of K-frames to the IUT with the L2CAP SDU Length smaller than the IUT MTU.

- Expected Outcome

Pass verdict

The IUT correctly reassembles the data received from the Lower Tester and sends it to the Upper Tester.

The data sent to the Upper Tester matches the data sent by the Lower Tester.

L2CAP/COS/CFC/BV-04-C [Data Receiving]

- Test Purpose

Verify that the IUT can receive unsegmented data correctly.

- Reference

[12] 3.4

- Initial Condition

- The appropriate signaling channel for the transport is used.
- An LE Data Channel is established on the SPSM declared via the TSPX_spsm IXIT value.
- The role of the IUT is indicated in the TSPX_iut_role_initiator IXIT value.

- Test Procedure

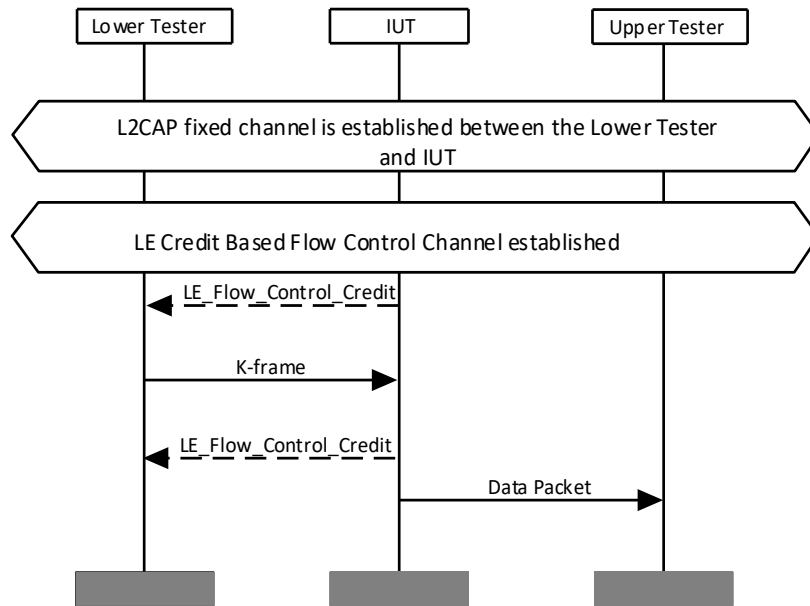

Figure 4.30: L2CAP/COS/CFC/BV-04-C [Data Receiving] MSC

(Optional) If the channel was created with zero credits, the Upper Tester issues a command to the IUT to send credits.

The Lower Tester sends data in a single K-frame to the IUT. The SDU length is less than or equal to the length of the K-frame - 2.

- Expected Outcome

Pass verdict

The IUT sends the received data to the Upper Tester

The data sent to the Upper Tester by the IUT matches the data sent by the Lower Tester to the IUT

L2CAP/COS/CFC/BV-05-C [Multiple Channels with Interleaved Data Streams]

- Test Purpose

Verify that an IUT can create multiple channels and receives data streams on the channels when the streams are interleaved.

- Reference

[12] 4.22

- Initial Condition

- The appropriate signaling channel for the transport is used.
- The LE Data Channel is established using the SPSM declared via the TSPX_spsm IXIT value.
- The role of the IUT is indicated in the TSPX_iut_role_initiator IXIT value.

- Test Procedure

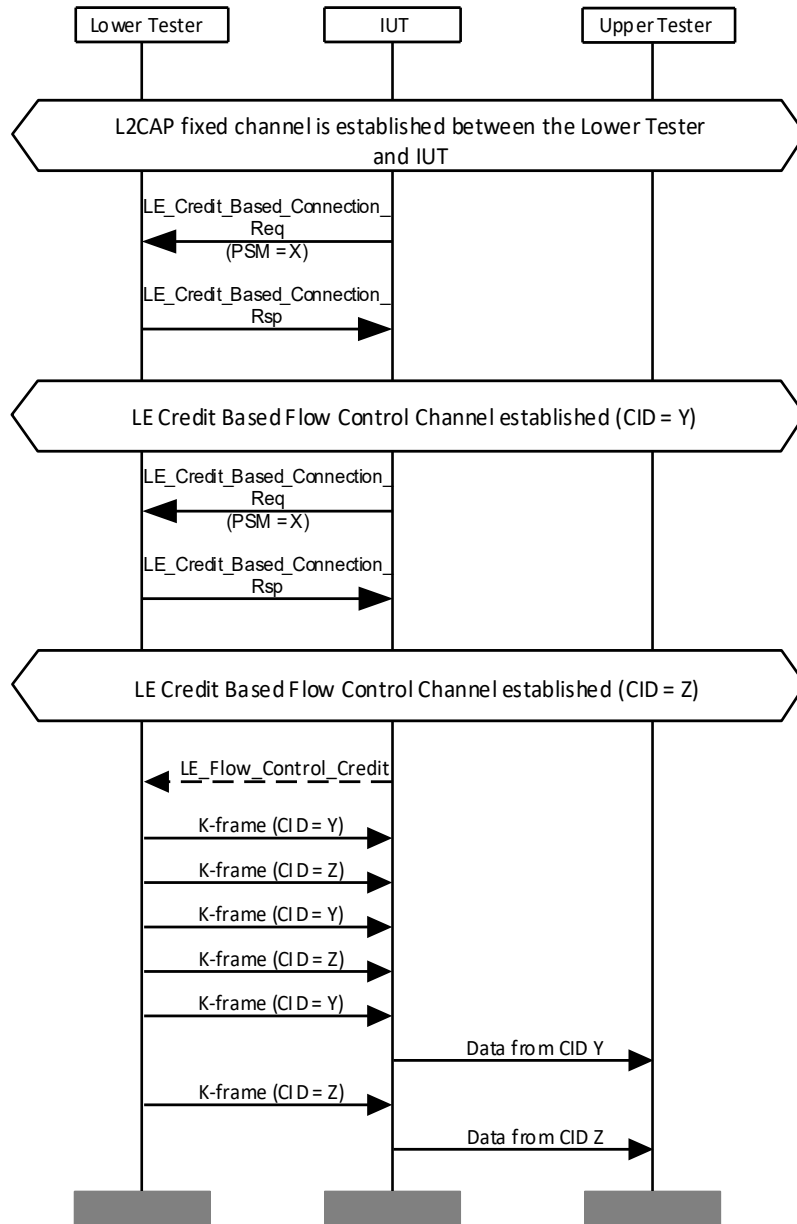

Figure 4.31: L2CAP/COS/CFC/BV-05-C [Multiple Channels with Interleaved Data Streams] MSC

(Optional) If the channel was created with zero credits, the Upper Tester issues a command to the IUT to send credits.

The Lower Tester sends data on the different channels interleaved.

- Expected Outcome

Pass verdict

The IUT sends the received data to the Upper Tester.

The data sent to the Upper Tester matches the data sent by the Lower Tester.

4.4.6.1 Recombination of Signaling Packets

- Test Purpose

Verify that the IUT correctly handles fragmented L2CAP signaling PDUs.

- Initial Condition

- The signaling channel specified in [Table 4.13](#) is used.
- An SPSM for the desired Credit Based or Enhanced Credit Based Flow Control based channel is declared via the TSPX_spsm IXIT value.

- Test Case Configuration

Test Case ID	Reference	Signaling Channel	L2CAP Command
L2CAP/LE/CFC/BV-30-C [Recombination of Signaling Packets]	[1] 4.22, 4.23	0x0005	L2CAP_LE_CREDIT_BASED_CONNECTION_REQ/RSP
L2CAP/ECFC/BV-39-C [Recombination of Signaling Packets - LE]	[1] 4.25, 4.26	0x0005	L2CAP_CREDIT_BASED_CONNECTION_REQ/RSP
L2CAP/ECFC/BV-40-C [Recombination of Signaling Packets – BR/EDR]	[1] 4.25, 4.26	0x0001	L2CAP_CREDIT_BASED_CONNECTION_REQ/RSP

Table 4.13: Recombination of Signaling Packets test cases



- Test Procedure

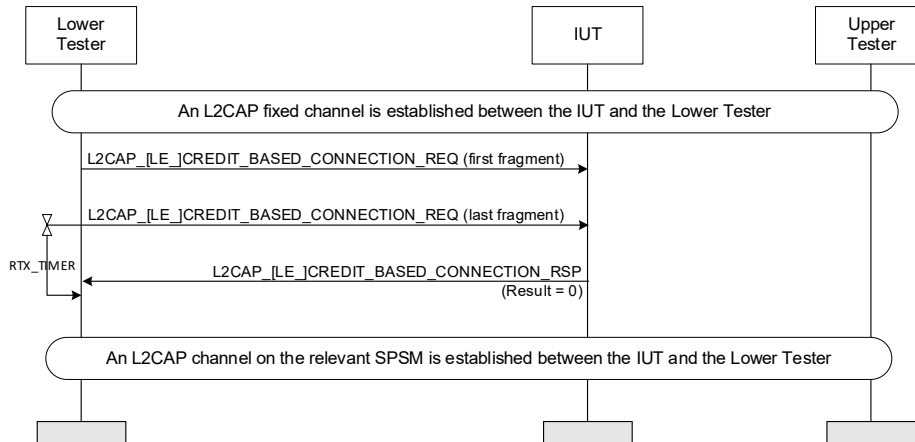

Figure 4.32: Recombination of Signaling Packets MSC

The L2CAP Credit Based Connection Request/Response commands are specified in [Table 4.13](#).

The Lower Tester sends a valid connection request command, with nonzero credits to the IUT on the SPSM specified in the initial condition, fragmented into two fragments.

The IUT responds with a connection request response and establishes the credit-based channel.

- Expected Outcome

Pass verdict

The IUT sends a correct connection request response in response to the connection request command received in the recombined C-frame.

- Note

It is allowed for the IUT to fragment its signaling packets, as well.

4.4.6.2 Recombination of Data Packets

- Test Purpose

Verify that the IUT correctly handles fragmented L2CAP data PDUs.

- Reference

[12] 3.4

- Initial Condition

- The signaling channel specified in [Table 4.14](#) is used.
- A Data Channel over the relevant bearer is established on the SPSM declared via the TSPX_spsm IXIT value using the commands specified in [Table 4.14](#).
- The role of the IUT is indicated in the TSPX_iut_role_initiator IXIT value.

- Test Case Configuration

Test Case ID	Reference	Signaling Channel	L2CAP Command
L2CAP/LE/CFC/BV-31-C [Recombination of Data Packets]	[1] 3.4, 7.2.2	0x0005	L2CAP_LE_CREDIT_BASED_CONNECTION_REQ/RSP
L2CAP/ECFC/BV-41-C [Recombination of Data Packets]	[1] 3.4, 7.2.2	0x0005	L2CAP_CREDIT_BASED_CONNECTION_REQ/RSP
L2CAP/ECFC/BV-42-C [Recombination of Data Packets]	[1] 3.4, 7.2.2	0x0001	L2CAP_CREDIT_BASED_CONNECTION_REQ/RSP

Table 4.14: Recombination of Data Packets test cases



- Test Procedure

(Optional, for LE Credit-based) If the channel has been created with zero credits, the Upper Tester issues a command to the IUT to send credits to the Lower Tester.

The Lower Tester sends Credit-based frames (K-frame) on the established CID, with PDU Length equal to 10 bytes, fragmented into two fragments.

The IUT recombines the fragments and sends the received data to the Upper Tester.

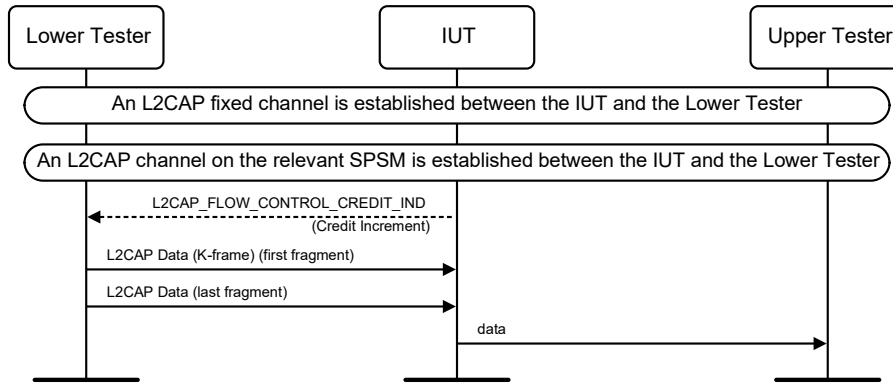

Figure 4.33: Recombination of Data Packets MSC

- Expected Outcome

Pass verdict

The IUT receives the fragments and recombines them into correctly formatted K-frames and sends the data to the Upper Tester. The data sent to the Upper Tester matches the data sent by the Lower Tester.

L2CAP/ECFC/BI-09-C [Incorrect Size Signaling Packets, BR/EDR]

- Test Purpose

Verify that the IUT properly handles L2CAP signaling PDUs that have invalid length over BR/EDR.

- Initial Condition

- The appropriate signaling channel for the transport is used.
- No security is used in this test case.
- An SPSM for the desired Credit Based Flow Control based channel is declared via the TSPX_spsm IXIT value.
- An ACL connection is established between the Lower Tester and the IUT.

• Test Procedure

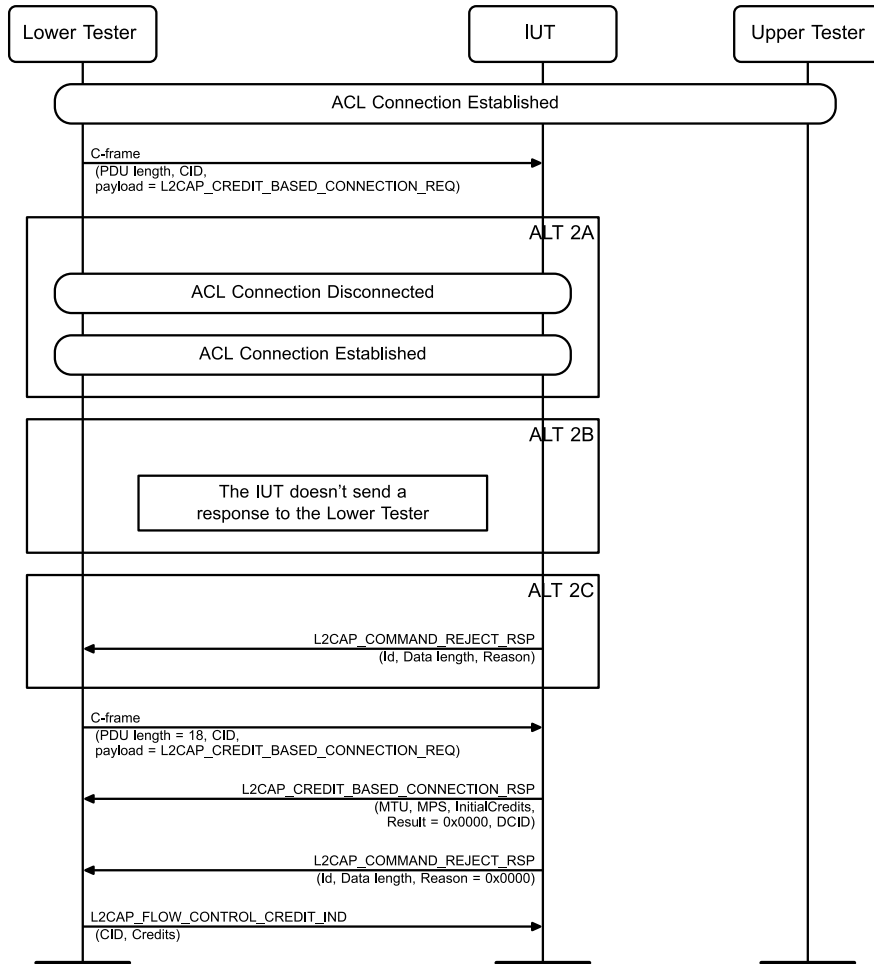

Figure 4.34: L2CAP/ECFC/BI-09-C [Incorrect Size Signaling Packets] MSC

1. The Lower Tester sends a C-frame to the IUT with PDU Length smaller than the signaling packet's actual size, Channel ID set to the correct signaling channel for the logical link, and the Information payload containing a correct L2CAP_CREDIT_BASED_CONNECTION_REQ packet. The L2CAP_CREDIT_BASED_CONNECTION_REQ packet contains only one SCID.
2. Perform either alternative 2A, 2B, or 2C depending on the IUT's response.
 - Alternative 2A (IUT disconnects the connection):
 - 2A.1 The IUT disconnects the ACL connection.
 - 2A.2 The IUT and the Lower Tester create an ACL connection.
 - Alternative 2B (IUT ignores the C-frame):
 - 2B.1 The IUT discards the frame.
 - Alternative 2C (IUT rejects the C-frame):
 - 2C.1 The IUT sends an L2CAP_COMMAND_REJECT_RSP to the Lower Tester with a valid Reason code.
3. The Lower Tester sends a C-frame to the IUT with PDU Length = 18, Channel ID set to the correct signaling channel for the logical link, and the Information payload containing a correct L2CAP_CREDIT_BASED_CONNECTION_REQ packet (of length 14 bytes), padded with "0"s. The L2CAP_CREDIT_BASED_CONNECTION_REQ packet contains only one SCID.

4. The IUT sends a correctly formatted L2CAP_CREDIT_BASED_CONNECTION_RSP to the Lower Tester and an L2CAP_COMMAND_REJECT_RSP rejecting the partial packet, with Reason = 0x0000 (“Command not understood”).
5. The Lower Tester sends a correctly formatted C-frame to the IUT with valid PDU Length and Channel ID set to the correct signaling channel for the logical link.

- Expected Outcome

Pass verdict

The IUT sends an L2CAP_CREDIT_BASED_CONNECTION_RSP only in response to the second C-frame.

In Step 5, the IUT correctly handles the received C-frame.

4.4.7 Enhanced Credit Based Flow Control Mode

Verify the correct implementation of the data channel in Enhanced Credit Based Flow Control mode.

4.4.7.1 Segmentation

- Test Purpose

Verify that the IUT can send data segments that are larger than the K-frame payload size.

- Reference

[13] 3.4

- Initial Condition

- The signaling channel specified in Table 4.15 is used.
- An SPSM for the desired Enhanced Credit Based Flow Control channel is declared via the TSPX_spsm IXIT value.
- A Data Channel as specified in Table 4.15 is established on the SPSM declared via the TSPX_spsm IXIT value with credits returned to the IUT by the Lower Tester.
- The role of the IUT is indicated in the TSPX_iut_role_initiator IXIT value.
- The Upper Tester can command the IUT to send data.

- Test Case Configuration

Test Case ID	Signaling Channel
L2CAP/COS/ECFC/BV-01-C [Segmentation, LE]	0x0005
L2CAP/COS/ECFC/BV-05-C [Segmentation, BR/EDR]	0x0001

Table 4.15: Segmentation test cases

- Test Procedure

Same as for L2CAP/COS/CFC/BV-01-C [Segmentation].

- Expected Outcome

Pass verdict

The IUT sends at least one K-frame containing data to the Lower Tester.

If the Upper Test sends a data packet to the IUT larger than the Lower Tester’s MPS and smaller than the Lower Tester’s MTU, the IUT segments the K-frames correctly.



4.4.7.2 Reassembling

- Test Purpose

Verify that the IUT can correctly reassemble data received from the Lower Tester where the L2CAP SDU Length is greater than the IUT K-frame payload size.

- Reference

[13] 3.4

- Initial Condition

- The signaling channel specified in [Table 4.16](#) is used.
- An SPSM for the desired Enhanced Credit Based Flow Control channel is declared via the TSPX_spsm IXIT value.
- A Data Channel as specified in [Table 4.16](#) is established on the SPSM declared via the TSPX_spsm IXIT value with credits returned to the IUT by the Lower Tester.
- The role of the IUT is indicated in the TSPX_iut_role_initiator IXIT value.

- Test Case Configuration

Test Case ID	Signaling Channel
L2CAP/COS/ECFC/BV-02-C [Reassembling, LE]	0x0005
L2CAP/COS/ECFC/BV-06-C [Reassembling, BR/EDR]	0x0001

Table 4.16: Reassembling test cases

- Test Procedure

Same as for [L2CAP/COS/CFC/BV-03-C \[Reassembling\]](#).

- Expected Outcome

Pass verdict

The IUT correctly reassembles the data received from the Lower Tester and sends it to the Upper Tester.

The data sent to the Upper Tester matches the data sent by the Lower Tester.

4.4.7.3 Multiple Channels with Interleaved Data Streams

- Test Purpose

Verify that an IUT can create multiple channels and receives data streams on the channels when the streams are interleaved.

- Reference

[13] 4.25

- Initial Condition

- The signaling channel specified in [Table 4.17](#) is used.
- The role of the IUT is indicated in the TSPX_iut_role_initiator IXIT value.

- An SPSM for the desired Enhanced Credit Based Flow Control channel is declared via the TSPX_spsm IXIT value.
 - The Upper Tester can command the IUT to create a credit based channel on the SPSM declared via the TSPX_spsm IXIT value, send data and credits.
- Test Case Configuration

Test Case ID	Signaling Channel
L2CAP/COS/ECFC/BV-03-C [Multiple Channels with Interleaved Data Streams, LE]	0x0005
L2CAP/COS/ECFC/BV-07-C [Multiple Channels with Interleaved Data Streams, BR/EDR]	0x0001

Table 4.17: Multiple Channels with Interleaved Data Streams test cases

- Test Procedure

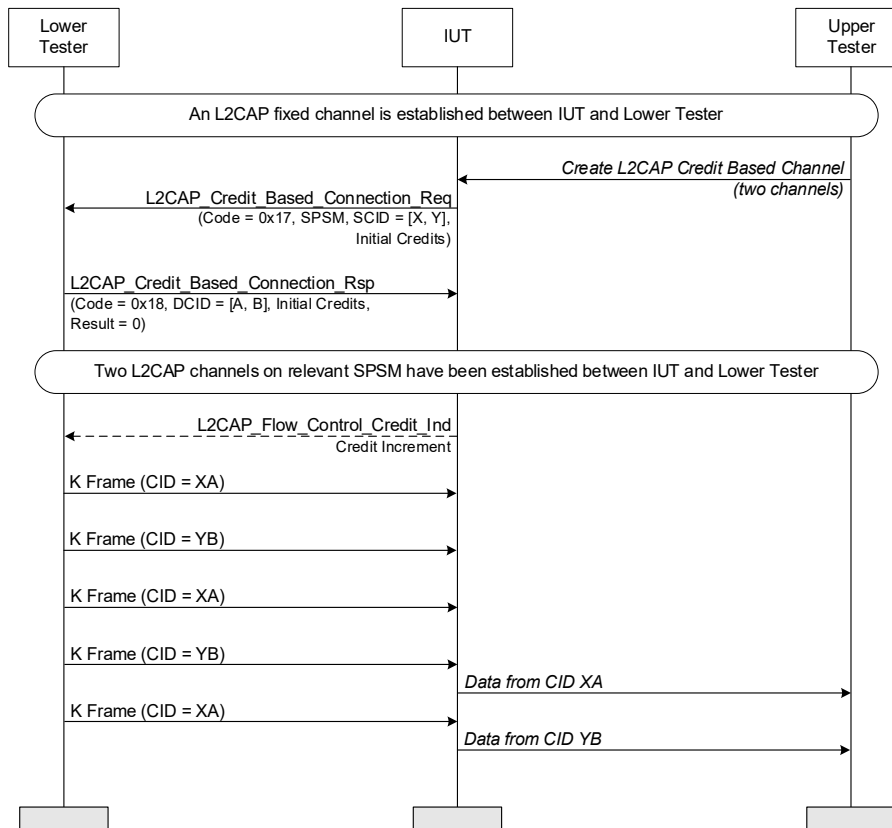

Figure 4.35: Multiple Channels with Interleaved Data Streams MSC

1. The Upper Tester commands the IUT to send a connection request on the SPSM, with two channels.
2. The IUT sends an L2CAP Credit Based Connection Request (Code = 0x17) to the Lower Tester, with two valid CIDs, on the SPSM.
3. The Lower Tester responds with an L2CAP Credit Based Connection Response (Code = 0x18), establishing all channels.
4. The Lower Tester sends K-Frames to the IUT, alternatively on the two established channels.

- Expected Outcome

Pass verdict

The IUT sends the received data to the Upper Tester.

The data sent to the Upper Tester matches the data sent by the Lower Tester.

4.4.7.4 Reassembling

- Test Purpose

Verify that the IUT can correctly report data received from the Lower Tester when MTU = MPS in the direction from the Lower Tester to the IUT and the data received length = MTU.

- Reference

[13] 3.4

- Initial Condition

- The signaling channel specified in [Table 4.18](#) is used.
- An SPSM for the Enhanced Credit Based Flow Control channel is declared via the TSPX_spsm IXIT value.
- A Data Channel as specified in [Table 4.18](#) is established on SPSM declared via the TSPX_spsm IXIT value with credits returned to the IUT by the Lower Tester.
- The role of the IUT is indicated in the TSPX_iut_role_initiator IXIT value.

- Test Case Configuration

Test Case ID	Signaling Channel
L2CAP/COS/ECFC/BV-04-C [Reassembling, LE]	0x0005
L2CAP/COS/ECFC/BV-08-C [Reassembling, BR/EDR]	0x0001

Table 4.18: Reassembling test cases

- Test Procedure

Same as for [L2CAP/COS/CFB/BV-04-C \[Data Receiving\]](#). The Credit Based Connection Request includes the MTU and MPS parameters set to the same value that is between the minimum and the IUT's MTU read by the Lower Tester. The length of the data sent by the Lower Tester is the same size as the MTU/MPS parameters in the Credit Based Connection Request.

- Expected Outcome

Pass verdict

The IUT correctly reports the data received from the Lower Tester to the Upper Tester.

The data sent to the Upper Tester matches the data sent by the Lower Tester.

4.5 Connection-Oriented Retransmission/Flow Control/Streaming modes

Verify the correct implementation of the features of the Retransmission, Flow Control, and Streaming modes of the connection-oriented L2CAP service.

4.5.1 Flow Control

Verify the correct implementation of the Flow Control feature.

L2CAP/COS/FLC/BV-01-C [Flow Control without Acks]

- Test Purpose

Verify that the IUT does not transmit packets with sequence numbers higher than flow control window when no acknowledgment is received.

- Reference

[1] 5.4, 7.4

- Initial Condition

- The IUT is in OPEN state for data channel with assigned CID. L2CAP connection configured as Flow Control only mode.

- Test Procedure

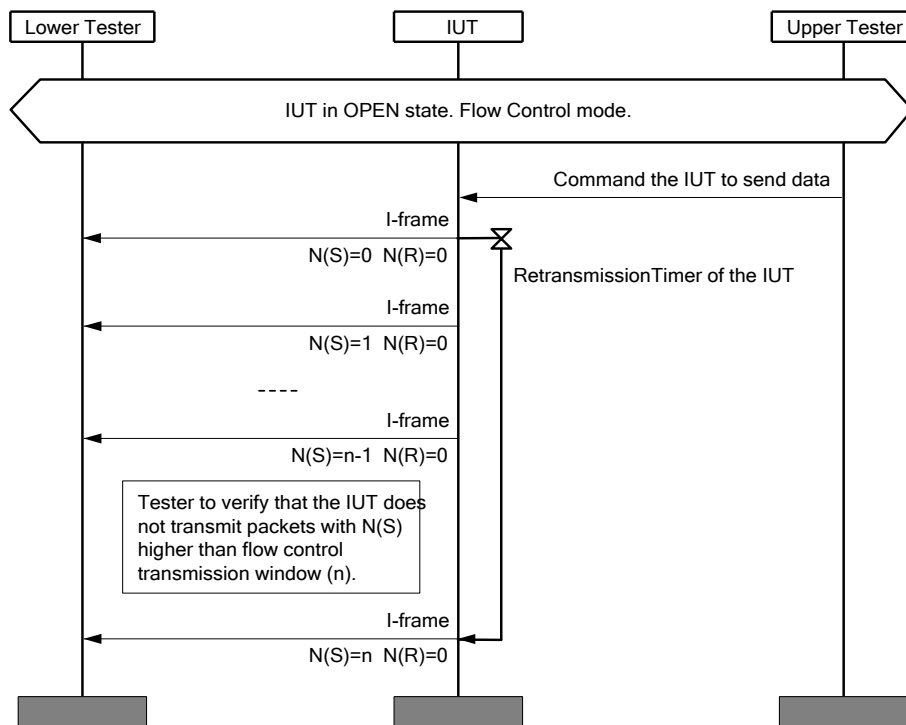

Figure 4.36: L2CAP/COS/FLC/BV-01-C [Flow Control without Acks] MSC

- Expected Outcome

Pass verdict

The IUT does not send any I-frames when the TxWindow is full until the RetransmissionTimer, which has been started with the sending of the first I-frame (N(S)=0), expires.

L2CAP/COS/FLC/BV-02-C [Resume Flow on RR Frame Ack]

- Test Purpose
Verify that the IUT resumes transmission on reception of acknowledgment in an RR frame.
- Reference
[1] 5.4, 7.4
- Initial Condition
 - The IUT is in OPEN state for data channel with assigned CID. L2CAP connection configured as Flow Control only mode.
- Test Procedure

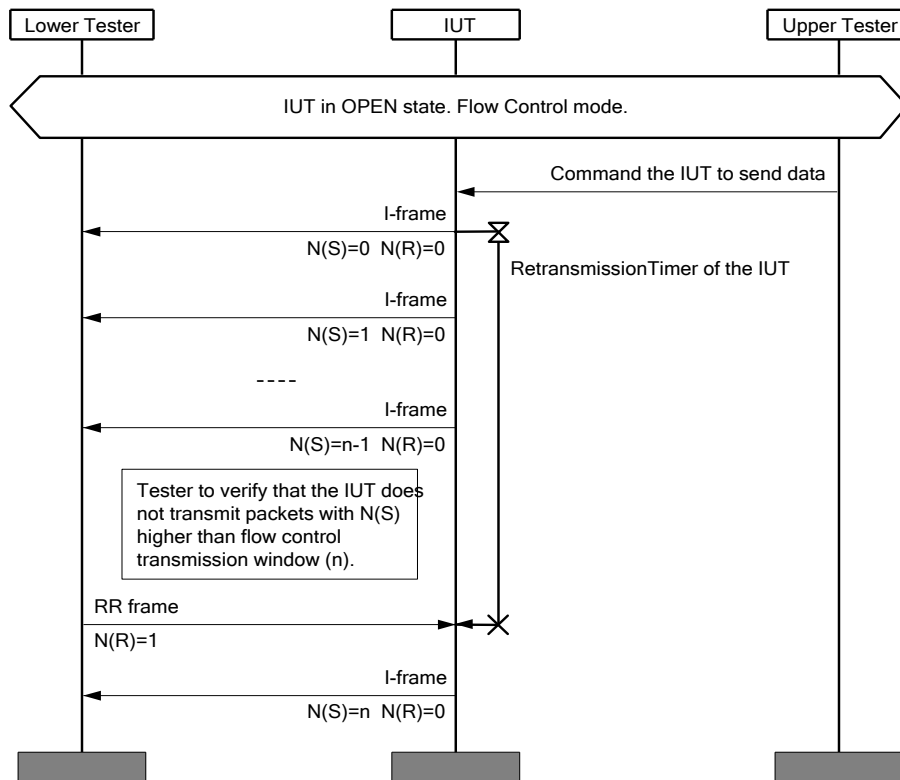

Figure 4.37: L2CAP/COS/FLC/BV-02-C [Resume Flow on RR Frame Ack] MSC

- Expected Outcome

Pass verdict

The IUT does not send any I-frames when the TxWindow is full and the IUT RetransmissionTimer, which has been started with the sending of the first I-frame (N(S)=0), has not expired yet.

The IUT resumes transmission when it receives acknowledgment for the first I-frame in a RR frame before IUT Retransmission time-out.

L2CAP/COS/FLC/BV-03-C [Resume Flow on I-frame Ack]

- Test Purpose

Verify that the IUT resumes transmission on the reception of acknowledgment in an I-frame.
- Reference

[1] 5.4, 7.4
- Initial Condition
 - The IUT is in OPEN state for data channel with assigned CID. L2CAP connection configured as Flow Control only mode.
- Test Procedure

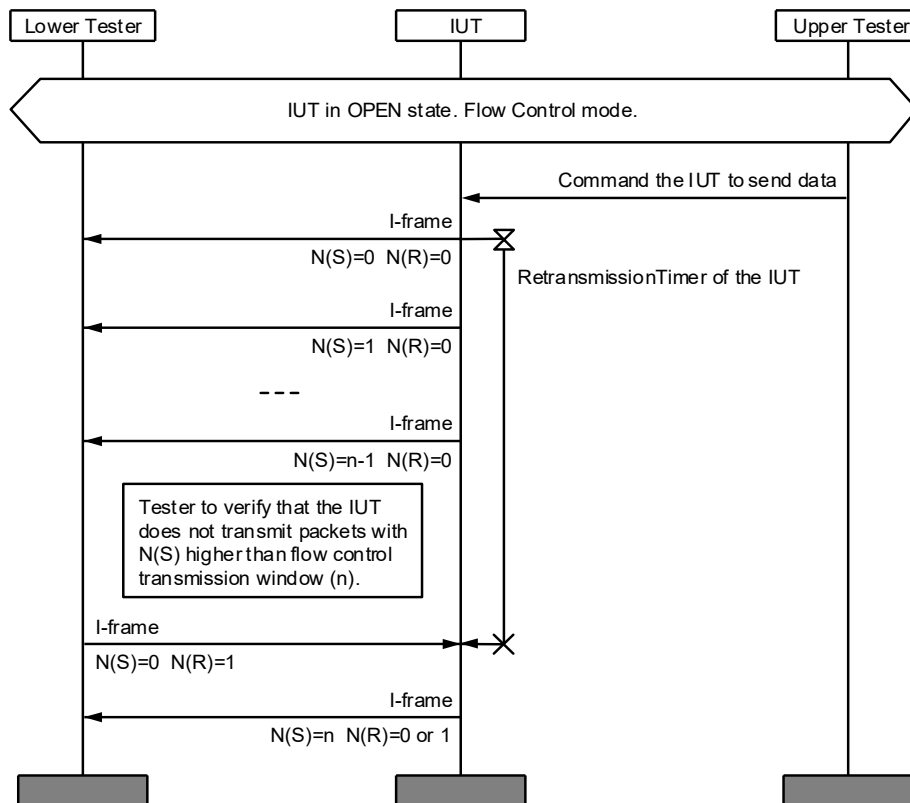

Figure 4.38: L2CAP/COS/FLC/BV-03-C [Resume Flow on I-frame Ack] MSC

- Expected Outcome

Pass verdict

The IUT does not send any I-frames when the TxWindow is full and the RetransmissionTimer, which has been started with the sending of the first I-frame (N(S)=0), has not expired yet.

The IUT resumes transmission when it receives an acknowledgment for the first I-frame in an I-frame sent by the Lower Tester before IUT Retransmission time-out.

L2CAP/COS/FLC/BV-04-C [Transmit RR Frame on Monitor Timeout]

- Test Purpose
Verify that the IUT transmits an RR frame after Monitor time-out.
- Reference
[1] 5.4, 7.4
- Initial Condition
 - The IUT is in OPEN state for data channel with assigned CID. L2CAP connection configured as Flow Control only mode.
- Test Procedure

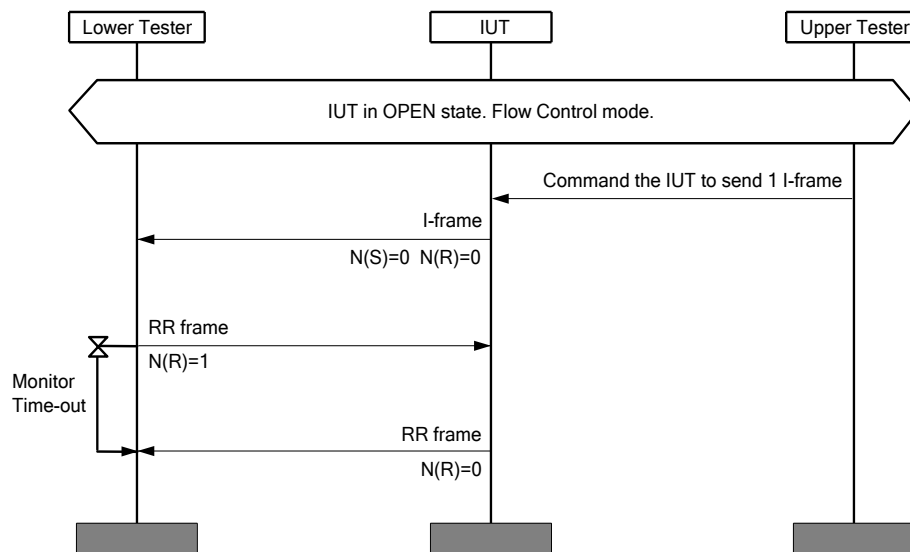

Figure 4.39: L2CAP/COS/FLC/BV-04-C [Transmit RR Frame on Monitor Timeout] MSC

- Expected Outcome
Pass verdict
The Lower Tester receives the IUT's RR frame within the timing window, [Monitor Time-out (+/- 10%)], after transmission of its own RR frame.
- Notes
The 10 percent timing window is to account for timing differences between IUT and Lower Tester, as well as minor measurement error.

4.5.2 Retransmission

Verify the correct implementation of the retransmission feature.

L2CAP/COS/RTX/BV-01-C [No Retransmission with R=1]

- Test Purpose
Verify that the IUT does not retransmit packets when the retransmission flag is set to R=1.
- Reference
[1] 5.3, 7.4

- Initial Condition
 - The IUT is in OPEN state for data channel with assigned CID. L2CAP connection configured as Retransmission mode.
- Test Procedure

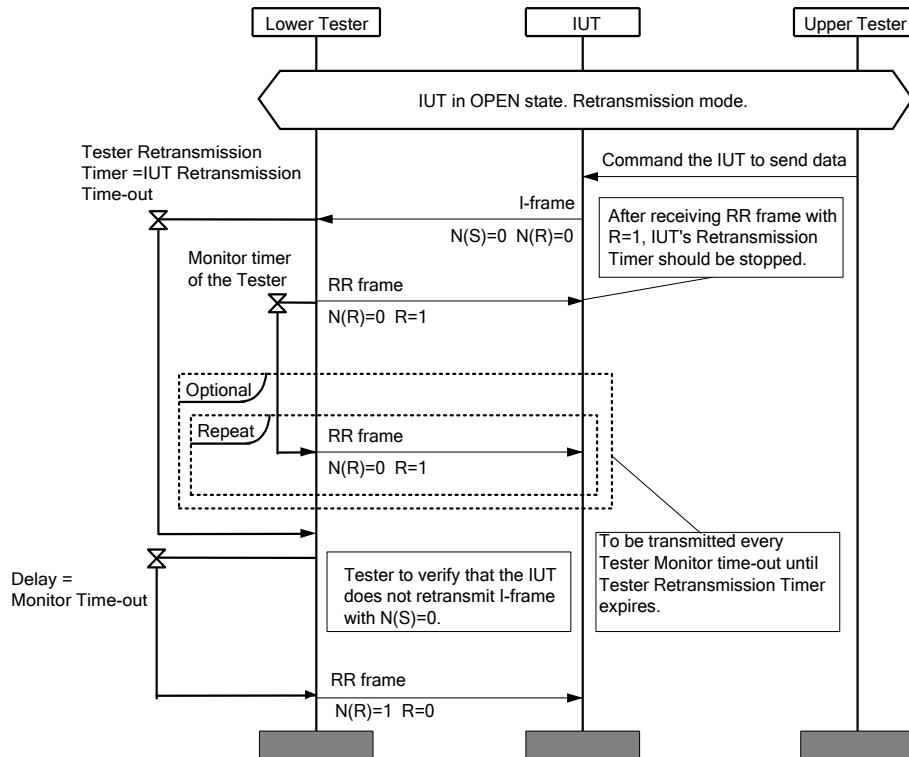

Figure 4.40: L2CAP/COS/RTX/BV-01-C [No Retransmission with R=1] MSC

- Expected Outcome
 - Pass verdict
 - The IUT does not retransmit an I-frame with sequence number $N(S)=0$ after IUT Retransmission time-out when the latest received R bit in a RR frame is 1.

L2CAP/COS/RTX/BV-02-C [Retransmission with R=0 in RR frame]

- Test Purpose
 - Verify that the IUT retransmits packets after retransmission time-out when the retransmission flag is set to R=0 received in a RR frame.
- Reference
 - [1] 5.3, 7.4
- Initial Condition
 - The IUT is in OPEN state for data channel with assigned CID. L2CAP connection configured as Retransmission mode.

- Test Procedure

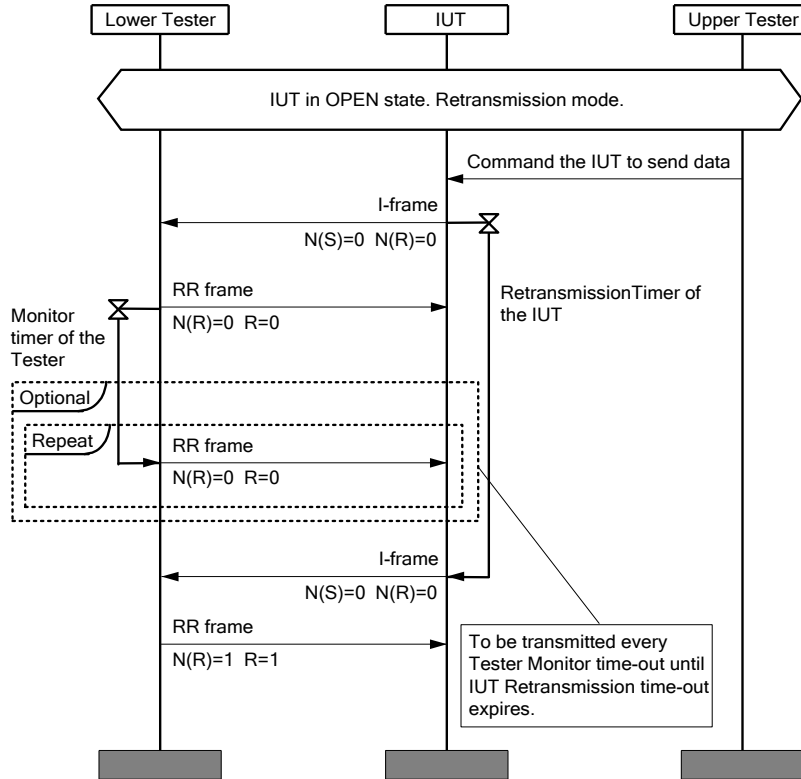

Figure 4.41: L2CAP/COS/RTX/BV-02-C [Retransmission with R=0 in RR frame] MSC

- Expected Outcome

Pass verdict

The IUT retransmits an I-frame with sequence number N(S)=0 after IUT Retransmission time-out when the latest received R bit in a RR frame is 0.

L2CAP/COS/RTX/BV-03-C [Retransmission with R=0 in I-frame]

- Test Purpose

Verify that the IUT retransmits packets after retransmission time-out when retransmission flag is set to R=0 received in an I-frame.

- Reference

[1] 5.3, 7.4

- Initial Condition

- The IUT is in OPEN state for data channel with assigned CID. L2CAP connection configured as Retransmission mode.

- Test Procedure

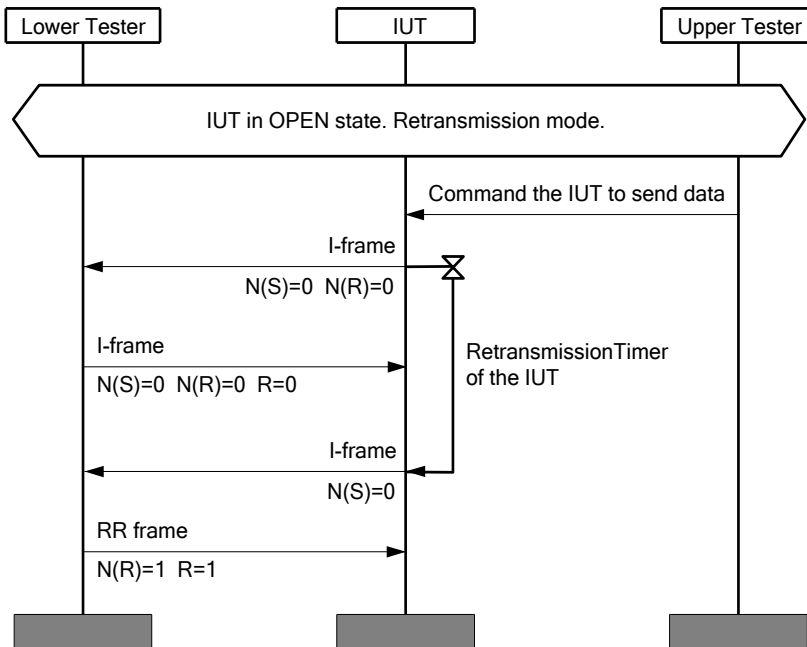

Figure 4.42: L2CAP/COS/RTX/BV-03-C [Retransmission with R=0 in I-frame] MSC

- Expected Outcome

Pass verdict

The IUT retransmits I-frame with sequence number $N(S)=0$ after IUT Retransmission time-out when latest received R bit in a I-frame is 0.

4.5.3 Extended Features (EXF)

Verify the correct implementation of the extended features information requests and responses of the L2CAP layer.

L2CAP/EXF/BV-07-C [Extended Features Information Response]

- Test Purpose

Verify that the IUT can format an Information Response for the information type of Extended Features.

- Reference

[1] 4.10, 4.11, 4.12

- Initial Condition

- An ACL connection has been established by the Lower Tester.

- Test Procedure

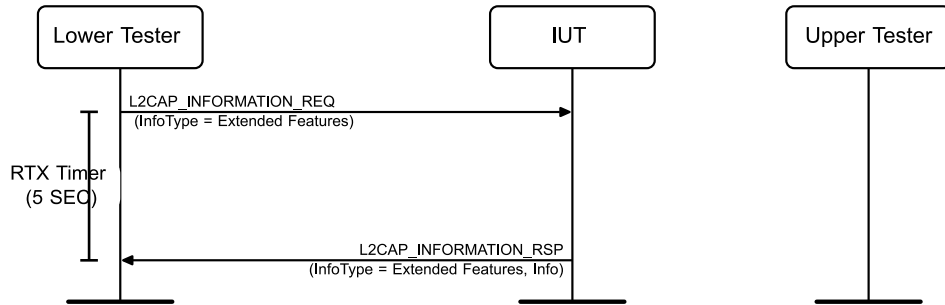

Figure 4.43: L2CAP/EXF/BV-07-C [Extended Features Information Response] MSC

- Expected Outcome

Pass verdict

The IUT sends Information Response [InfoType = Extended Features] and with a result code of Success and containing extended features supported defined by the ICS as mapped by Table 3.1 in [5].

L2CAP/EXF/BV-08-C [Information Request, Extended Features]

- Test Purpose

Verify that the IUT returns the proper L2CAP Extended Features in response to the Information Request from the Lower Tester.

- Reference

[11] 4.10

- Initial Condition

- The IUT is in the CLOSED state.
- No ACL link exists.
- The IUT acts as an L2CAP acceptor.

- Test Procedure

The Lower Tester sends an information request to the IUT.

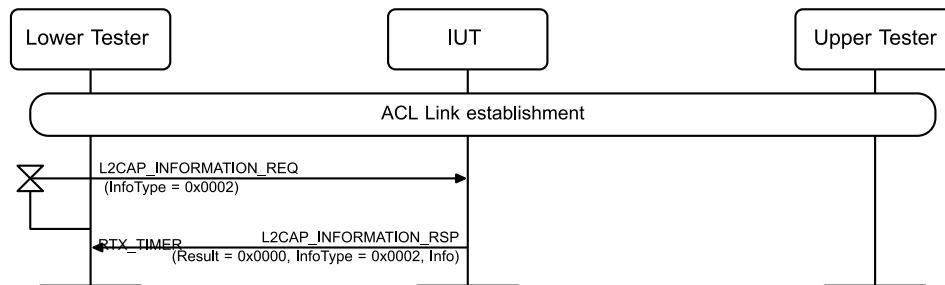

Figure 4.44: L2CAP/EXF/BV-08-C [Information Request, Extended Features] MSC

- Expected Outcome

Pass verdict

The IUT sends an L2CAP_INFORMATION_RSP PDU to the Lower Tester with the Info parameter containing 4 octets that match the ICS entries as shown in [Table 4.19](#) and all bits not listed are set to 0b0.

Feature	Octet	Bit	ICS
Flow Control mode	0	0	L2CAP 2/11
Retransmission mode	0	1	L2CAP 2/10
Bi-directional QoS	0	2	L2CAP 3/7
Enhanced Retransmission mode	0	3	L2CAP 2/12
Streaming mode	0	4	L2CAP 2/13
FCS Option	0	5	L2CAP 2/14
Extended Flow Specification for BR/EDR	0	6	L2CAP 2/38
Fixed Channels supported over BR/EDR	0	7	L2CAP 2/30
Extended Window Size	1	0	L2CAP 2/39
Unicast Connectionless Data Reception	1	1	L2CAP 2/35
Enhanced Credit Based Flow Control mode over BR/EDR	1	2	L2CAP 2/48a

Table 4.19: Extended Feature Mask bits

- Notes

The Lower Tester's RTX timer is set to maximum allowed initial value.

4.5.4 Channel Mode Configuration (CMC)

Verify the configuration of L2CAP channels using the various L2CAP supported modes.

L2CAP/CMC/BV-01-C [IUT Initiated Configuration of Enhanced Retransmission Mode]

- Test Purpose

Verify that the IUT can send a Configuration Request command containing the F&EC option that specifies Enhanced Retransmission Mode.

- Reference

[1] 4.4, 4.5, 5.4, 6.1.4, 7.1

- Initial Condition

- The IUT has established that the peer L2CAP entity supports Enhanced Retransmission Mode (using the Information Request/Response [Extended Features] mechanism).
- The channel connection has been established by the Lower Tester.

- Test Procedure

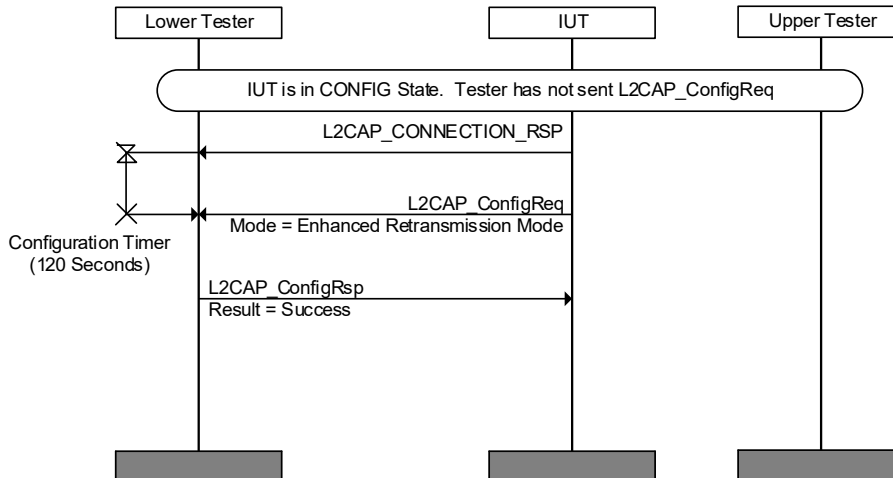

Figure 4.45: L2CAP/CMC/BV-01-C [IUT Initiated Configuration of Enhanced Retransmission Mode] MSC

- Expected Outcome

Pass verdict

The IUT sends a correctly formatted L2CAP Configure Request for Enhanced Retransmission Mode before the Lower Tester configuration timer (120 seconds) expires.

L2CAP/CMC/BV-02-C [Lower Tester Initiated Configuration of Enhanced Retransmission Mode]

- Test Purpose

Verify that the IUT can accept a Configuration Request from the Lower Tester containing an F&EC option that specifies Enhanced Retransmission Mode.

- Reference

[1] 4.4, 4.5, 5.4, 6.1.4, 7.1

- Initial Condition

- Test [L2CAP/CMC/BV-01-C \[IUT Initiated Configuration of Enhanced Retransmission Mode\]](#) has been performed successfully.

- Test Procedure

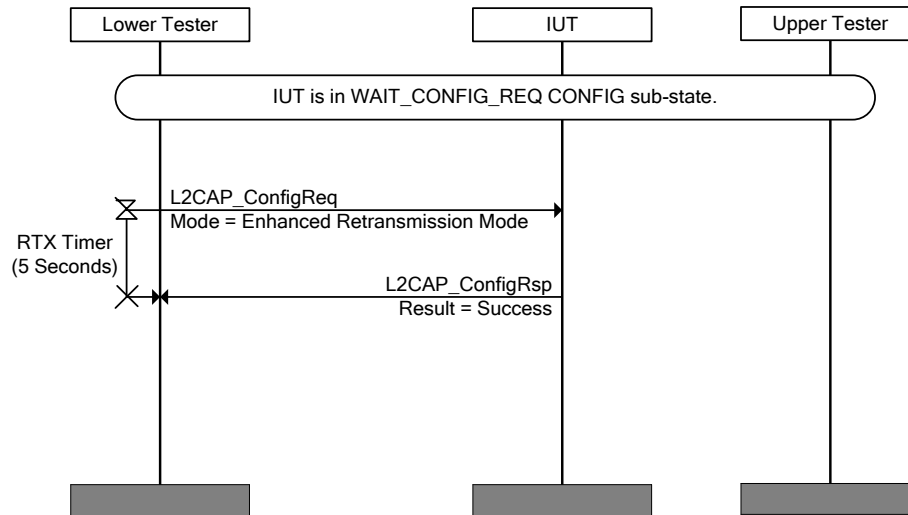

Figure 4.46: L2CAP/CMC/BV-02-C [Lower Tester Initiated Configuration of Enhanced Retransmission Mode] MSC

- Expected Outcome

Pass verdict

The IUT sends an L2CAP_CONFIGURATION_RSP before the Lower Tester TSPX_timer_rtx timer expires with a result code of “Success.”

L2CAP/CMC/BV-03-C [Failed Configuration of Enhanced Retransmission Mode when use of the Mode is Optional]

- Test Purpose

When configuring a PSM that can optionally support ERTM, verify that the IUT can handle receipt (renegotiate the channel mode in accordance with the specification) of a Configure Response indicating the peer L2CAP entity doesn’t wish to use Enhanced Retransmission Mode (Configure Response Result = Reject Unacceptable Parameters).

- Reference

[1] 4.4, 4.5, 5.4, 6.1.4, 7.1

- Initial Condition

- The IUT has established that the peer L2CAP entity supports Enhanced Retransmission Mode (using the Information Request/Response [Extended Features] mechanism).
- The channel connection has completed.

- Test Procedure

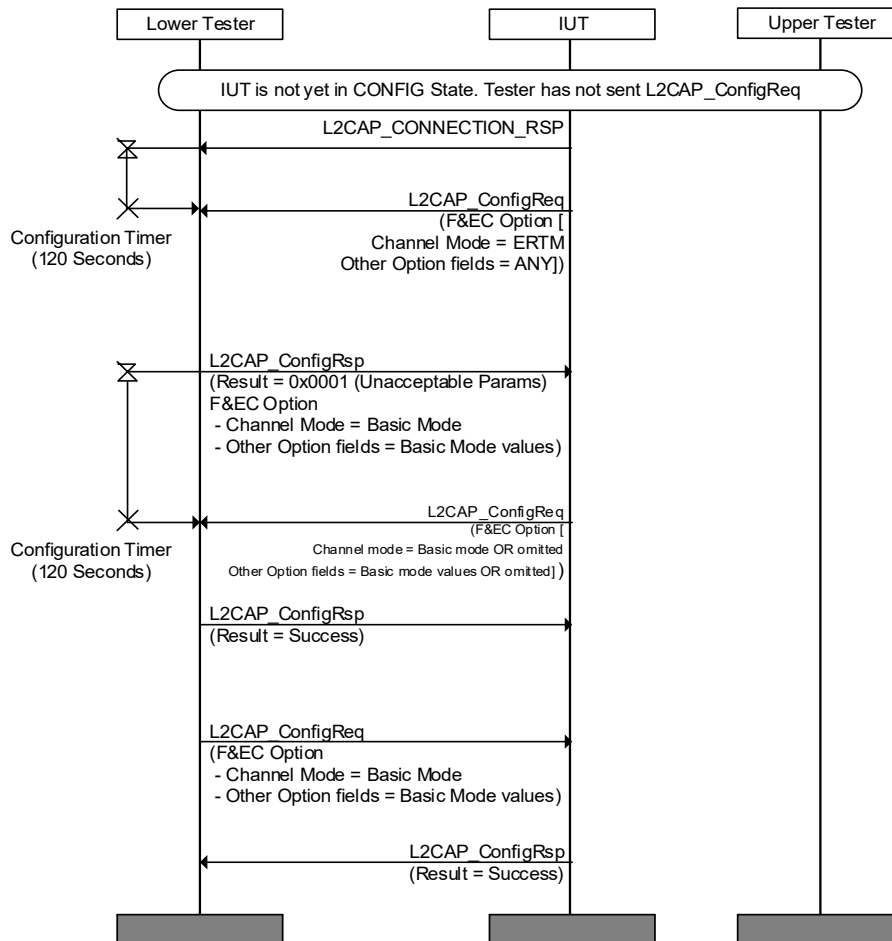

Figure 4.47: L2CAP/CMC/BV-03-C [Failed Configuration of Enhanced Retransmission Mode when use of the Mode is Optional] MSC

- Expected Outcome

Pass verdict

The channel is successfully configured to Basic Mode.

L2CAP/CMC/BV-04-C [IUT Initiated Configuration of Streaming Mode]

- Test Purpose

Verify that the IUT can send a Configuration Request command containing the F&EC option that specifies Streaming Mode.

- Reference

[1] 4.4, 4.5, 5.4, 6.1.4, 7.1

- Initial Condition

- The IUT has established that the peer L2CAP entity supports the Streaming Mode (using the Information Request/Response [Extended Features] mechanism).
- The channel connection has been established by the Lower Tester.

- Test Procedure

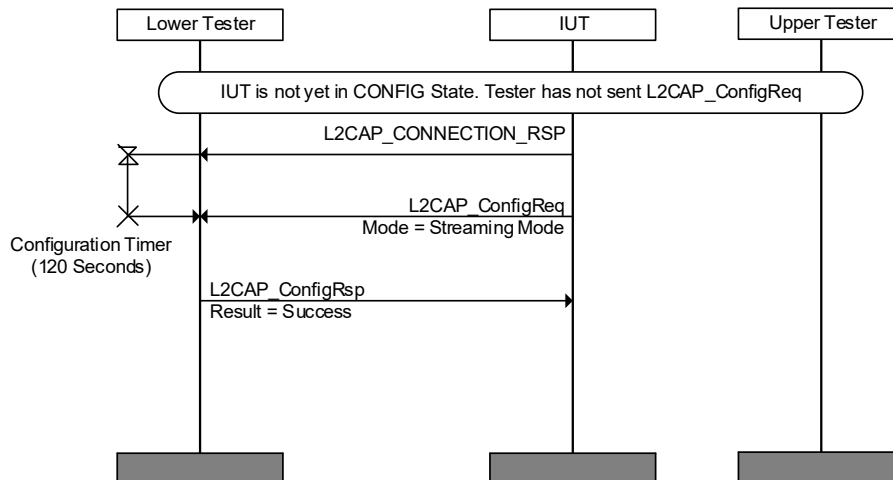

Figure 4.48: L2CAP/CMC/BV-04-C [IUT Initiated Configuration of Streaming Mode] MSC

- Expected Outcome

Pass verdict

The IUT sends a correctly formatted L2CAP Configure Request for Streaming Mode before the Lower Tester Configuration Timer (120 seconds) expires.

L2CAP/CMC/BV-05-C [Lower Tester Initiated Configuration of Streaming Mode]

- Test Purpose

Verify that the IUT can accept a Configuration Request from the Lower Tester containing an F&EC option that specifies Streaming Mode.

- Reference

[1] 4.4, 4.5, 5.4, 6.1.4, 7.1

- Initial Condition

- Test [L2CAP/CMC/BV-04-C \[IUT Initiated Configuration of Streaming Mode\]](#) has been performed successfully.

- Test Procedure

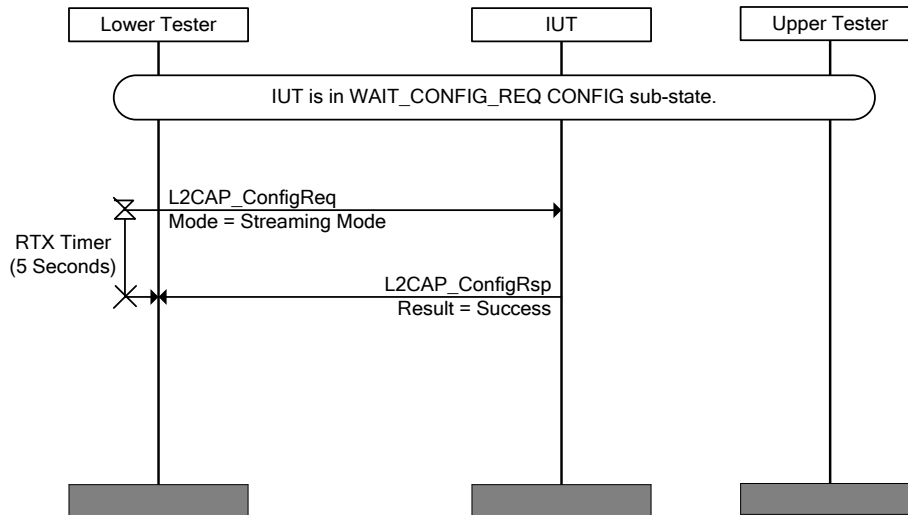

Figure 4.49: L2CAP/CMC/BV-05-C [Lower Tester Initiated Configuration of Streaming Mode] MSC

- Expected Outcome

Pass verdict

The IUT sends an L2CAP_CONFIGURATION_RSP before the Lower Tester RTX timer expires with a result code of "Success."

L2CAP/CMC/BV-06-C [Failed Configuration of Streaming Mode when use of the Mode is Optional]

- Test Purpose

When configuring a PSM that can optionally support Streaming Mode, verify that the IUT can handle receipt (renegotiate the channel mode in accordance with the specification) of a Configure Response indicating the peer L2CAP entity does not wish to use the tested mode (Configure Response Result = Reject Unacceptable Parameters).

- Reference

[1] 4.4, 4.5, 5.4, 6.1.4, 7.1

- Initial Condition

- The IUT has established that the peer L2CAP entity supports Streaming Mode (using the Information Request/Response [Extended Features] mechanism).
- The channel connection has completed.

- Test Procedure

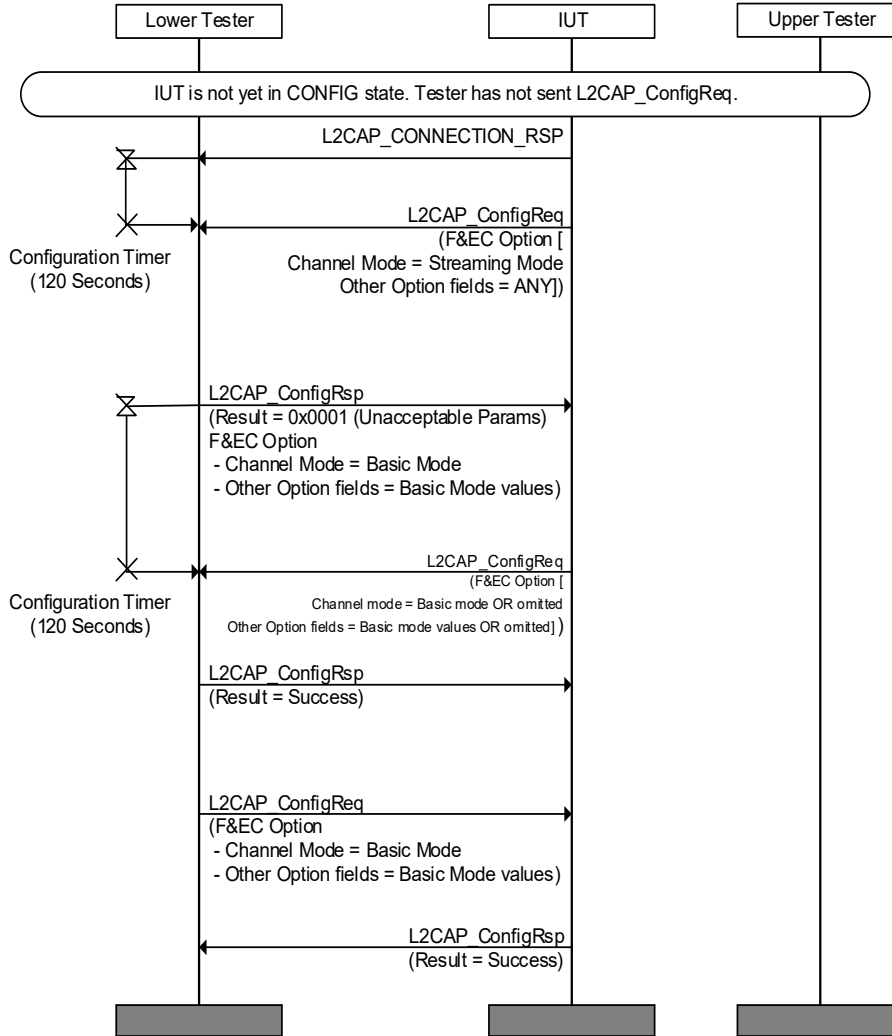

Figure 4.50: L2CAP/CMC/BV-06-C [Failed Configuration of Streaming Mode when use of the Mode is Optional] MSC

- Expected Outcome

Pass verdict

The channel is successfully configured to Basic Mode.

L2CAP/CMC/BV-07-C [Configuration Mode mismatch when use of Enhanced Retransmission Mode is Optional]

- Test Purpose

When configuring a PSM that can optionally support the use of ERTM, verify that the IUT renegotiates the channel mode to Basic Mode if the Lower Tester attempts to configure Basic Mode.

- Reference

[1] 4.4, 4.5, 5.4, 6.1.4, 7.1

- Initial Condition
 - The IUT has established that the peer L2CAP entity supports Enhanced Retransmission Mode (using the Information Request/Response [Extended Features] mechanism).
 - The channel connection has completed.
- Test Procedure

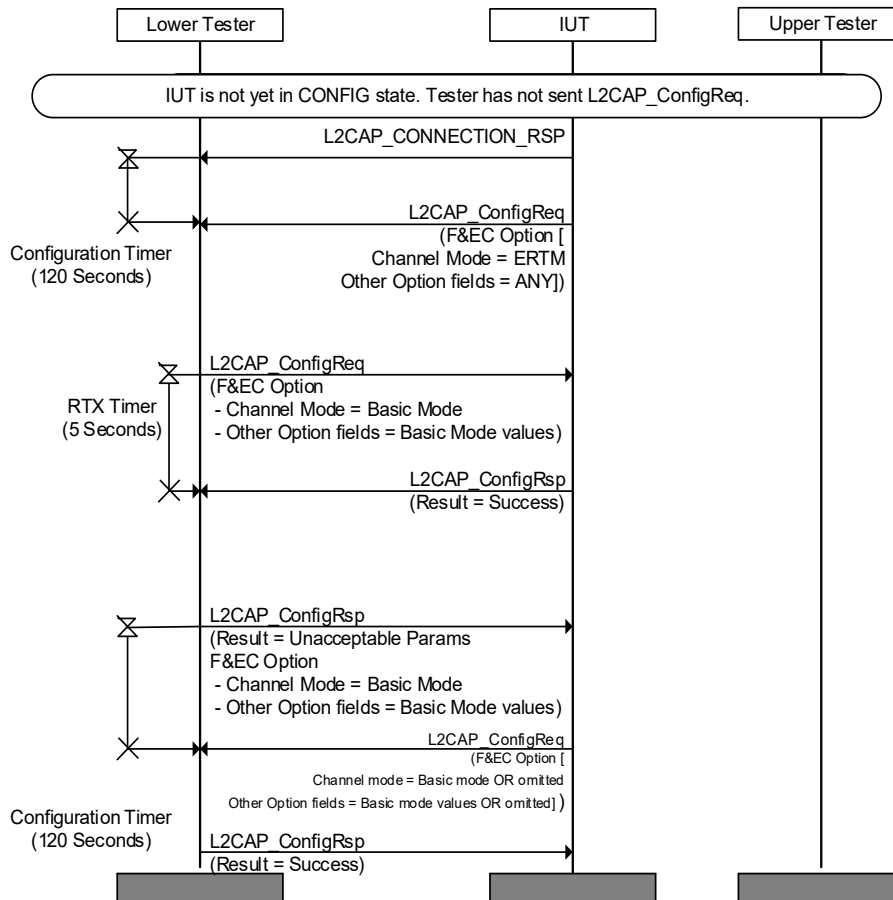

Figure 4.51: L2CAP/CMC/BV-07-C [Configuration Mode mismatch when use of Enhanced Retransmission Mode is Optional] MSC

- Expected Outcome

Pass verdict

The channel is successfully configured to Basic Mode.

L2CAP/CMC/BV-08-C [Configuration Mode Mismatch when use of Streaming Mode is Optional]

- Test Purpose

When configuring a PSM that can optionally support the use of Streaming Mode, verify that the IUT renegotiates the channel mode to Basic Mode if the Lower Tester attempts to configure Basic Mode.

- Reference

[1] 4.4, 4.5, 5.4, 6.1.4, 7.1



- Initial Condition
 - The IUT has established that the peer L2CAP entity supports Streaming Mode (using the Information Request/Response [Extended Features] mechanism).
 - The channel connection has completed.
- Test Procedure

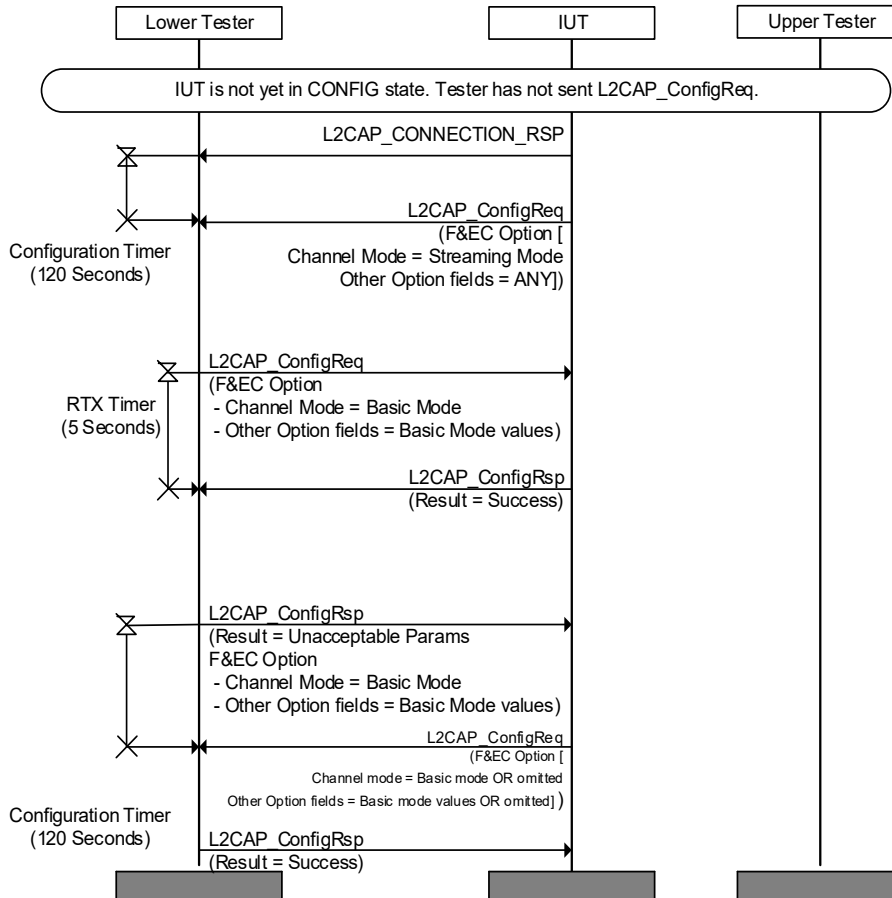

Figure 4.52: L2CAP/CMC/BV-08-C [Configuration Mode Mismatch when use of Streaming Mode is Optional] MSC

- Expected Outcome

Pass verdict

The channel is successfully configured to Basic Mode.

L2CAP/CMC/BV-09-C [Configuration to Basic Mode by the IUT]

- Test Purpose

The IUT wishes to use Basic Mode when configuring a PSM that can optionally support the use of ERTM or Streaming Mode. Verify that the IUT correctly rejects the request for ERTM or Streaming Mode from the Lower Tester.

- Reference

[1] 4.4, 4.5, 5.4, 6.1.4, 7.1

- Initial Condition
 - The Lower Tester has determined which Enhanced L2CAP Mode the IUT supports (using the Information Request/Response [Extended Features] mechanism). If the IUT supports both, the Lower Tester attempts to configure ERTM.
 - The channel connection has completed.
- Test Procedure

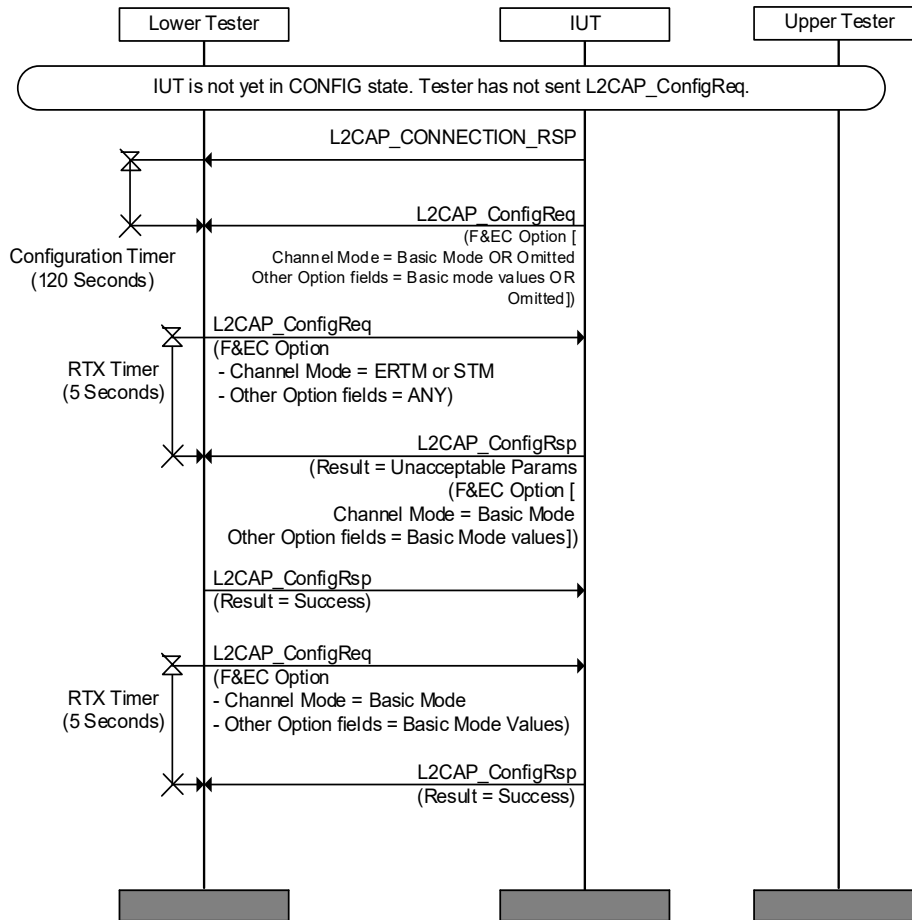

Figure 4.53: L2CAP/CMC/BV-09-C [Configuration to Basic Mode by the IUT] MSC

- Expected Outcome

Pass verdict

The IUT sends a Configure Response with result code of Unacceptable Parameters to the request from the Lower Tester for ERTM or STM.

The channel is successfully configured for Basic Mode.

L2CAP/CMC/BI-01-C [Failed Configuration of Enhanced Retransmission Mode when use of the Mode is Mandatory]

• Test Purpose

When creating a connection for a PSM that mandates the use of ERTM, verify that the IUT can handle receipt (close the channel in accordance with the specification) of a Configure Response indicating the peer L2CAP entity does not wish to use Enhanced Retransmission Mode (Configure Response Result = Reject Unacceptable Parameters).

• Reference

[1] 4.4, 4.5, 5.4, 6.1.4, 7.1

• Initial Condition

- The IUT has established that the peer L2CAP entity supports Enhanced Retransmission Mode (using the Information Request/Response [Extended Features] mechanism).
- The channel connection has completed.

• Test Procedure

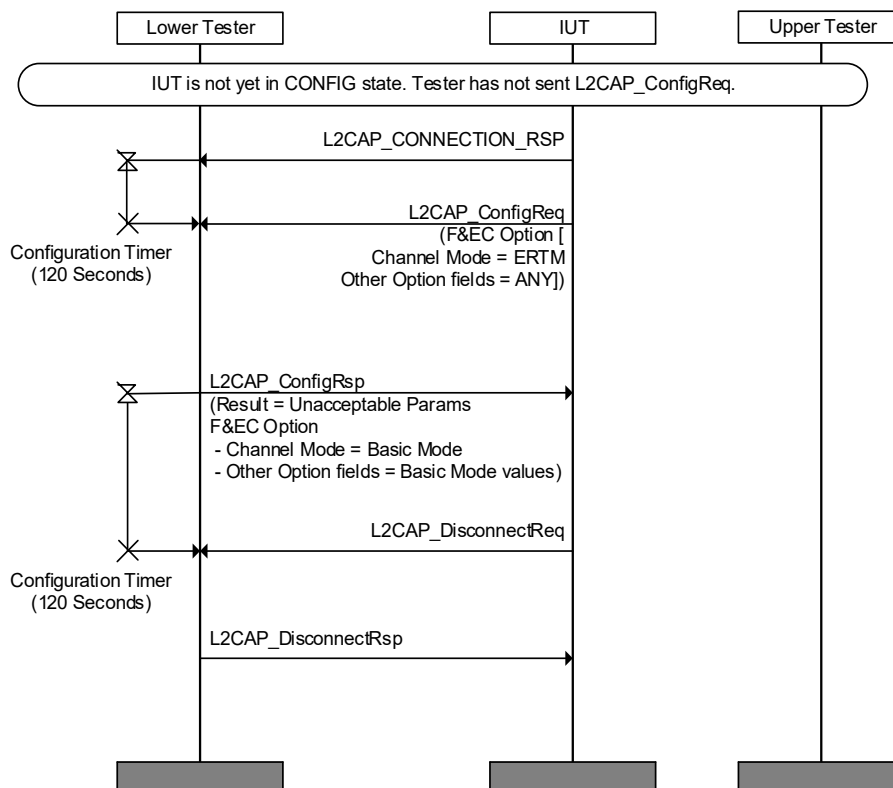

Figure 4.54: L2CAP/CMC/BI-01-C [Failed Configuration of Enhanced Retransmission Mode when use of the Mode is Mandatory] MSC

• Expected Outcome

Pass verdict

The IUT initiates closure of the channel.

L2CAP/CMC/BI-02-C [Configuration Mode mismatch when use of Enhanced Retransmission Mode is Mandatory]

- Test Purpose

When creating a connection for a PSM that mandates the use of ERTM, verify that the IUT closes the channel if the Lower Tester attempts to configure Basic Mode.

- Reference

[1] 4.4, 4.5, 5.4, 6.1.4, 7.1

- Initial Condition

- The IUT has established that the peer L2CAP entity supports Enhanced Retransmission Mode (using the Information Request/Response [Extended Features] mechanism).
- The channel connection has completed.

- Test Procedure

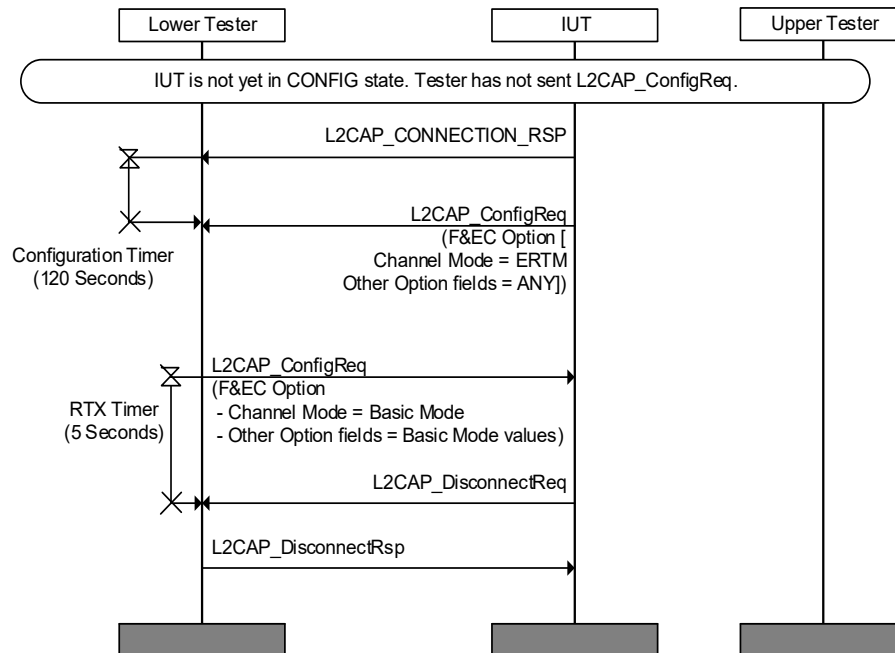

Figure 4.55: L2CAP/CMC/BI-02-C [Configuration Mode mismatch when use of Enhanced Retransmission Mode is Mandatory] MSC

- Expected Outcome

Pass verdict

The IUT initiates closure of the channel.

L2CAP/CMC/BI-03-C [Failed Configuration of Streaming Mode when use of the Mode is Mandatory]

- Test Purpose

When creating a connection for a PSM that mandates the use of Streaming Mode, verify that the IUT can handle receipt (close the channel in accordance with the specification) of a Configure Response indicating the peer L2CAP entity does not wish to use Streaming Mode (Configure Response Result = Reject Unacceptable Parameters).

- Reference
 - [1] 4.4, 4.5, 5.4, 6.1.4, 7.1
- Initial Condition
 - The IUT has established that the peer L2CAP entity supports Streaming Mode (using the Information Request/Response [Extended Features] mechanism).
 - The channel connection has completed.
- Test Procedure

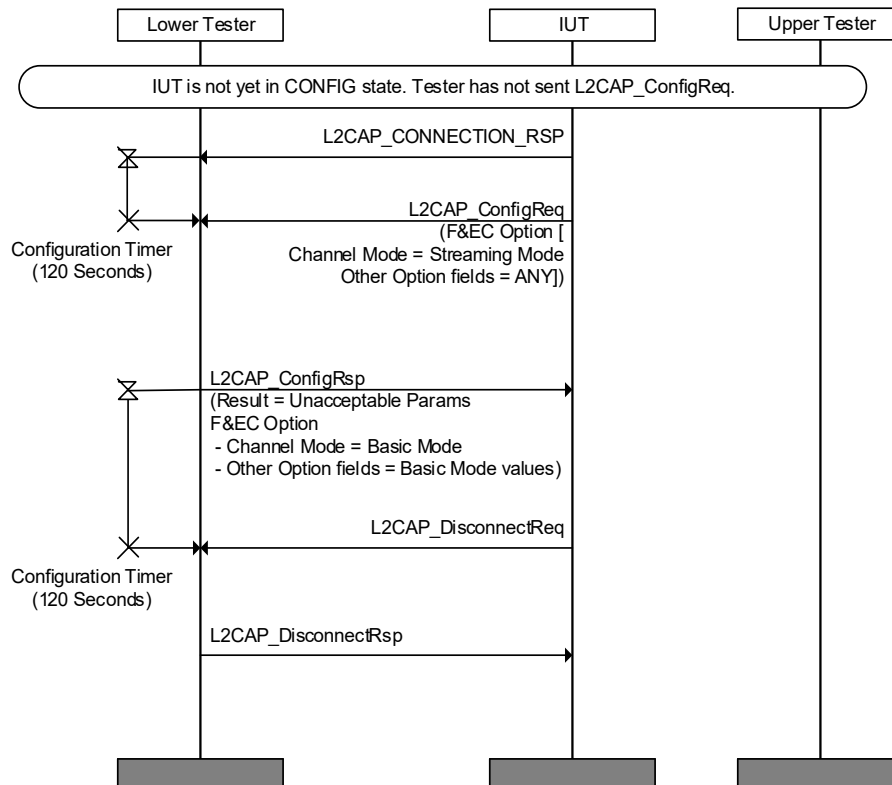

Figure 4.56: L2CAP/CMC/BI-03-C [Failed Configuration of Streaming Mode when use of the Mode is Mandatory] MSC

- Expected Outcome
 - Pass verdict
 - The IUT initiates closure of the channel.

L2CAP/CMC/BI-04-C [Configuration Mode mismatch when use of Streaming Mode is Mandatory]

- Test Purpose
 - When creating a connection for a PSM that mandates the use of Streaming Mode, verify that the IUT closes the channel if the Lower Tester attempts to configure Basic Mode.
- Reference
 - [1] 4.4, 4.5, 5.4, 6.1.4, 7.1

- Initial Condition
 - The IUT has established that the peer L2CAP entity supports Streaming Mode (using the Information Request/Response [Extended Features] mechanism).
 - The channel connection has completed.
- Test Procedure

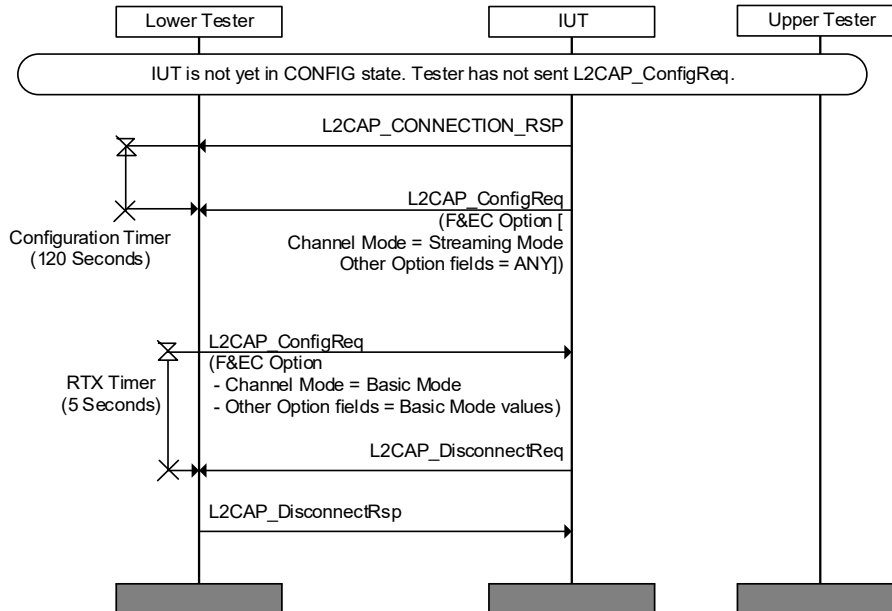

Figure 4.57: L2CAP/CMC/BI-04-C [Configuration Mode mismatch when use of Streaming Mode is Mandatory] MSC

- Expected Outcome

Pass verdict

The IUT initiates closure of the channel.

L2CAP/CMC/BI-05-C [Failed Configuration to Basic Mode by the IUT]

- Test Purpose

The IUT wishes to use Basic Mode when configuring a PSM that can optionally support the use of ERTM or Streaming Mode. Verify that the IUT initiates channel closure if the Lower Tester refuses to negotiate the channel to Basic Mode.
- Reference

[1] 4.4, 4.5, 5.4, 6.1.4, 7.1
- Initial Condition
 - The Lower Tester has determined which Enhanced L2CAP Mode the IUT supports (using the Information Request/Response [Extended Features] mechanism). If the IUT supports both, the Lower Tester attempts to configure ERTM.
 - The channel connection has completed.

- Test Procedure

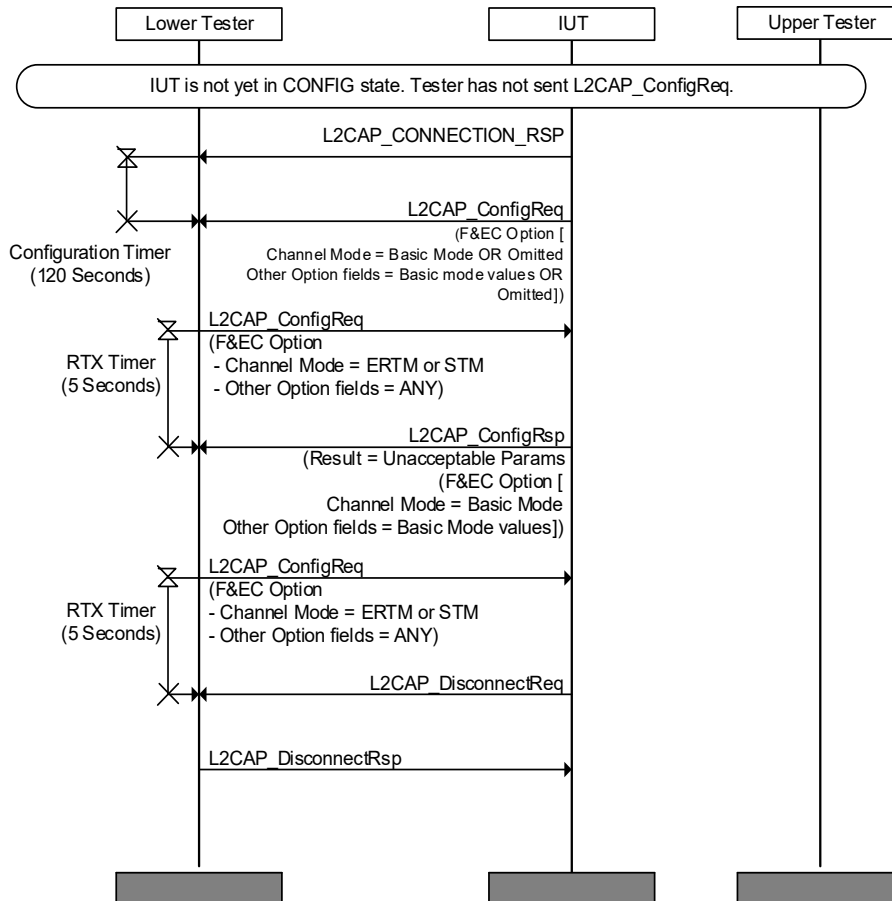

Figure 4.58: L2CAP/CMC/BI-05-C [Failed Configuration to Basic Mode by the IUT] MSC

- Expected Outcome

Pass verdict

The IUT sends a Configure Response with result code of Unacceptable Parameters to the request from the Lower Tester for ERTM.

The IUT initiates closure of the channel when it receives the second Configure Request for ERTM from the Lower Tester.

L2CAP/CMC/BI-06-C [Configuration to Basic Mode Rejected by the Lower Tester]

- Test Purpose

The IUT wishes to use Basic Mode when configuring a PSM that can optionally support the use of ERTM or Streaming Mode. Verify that the IUT initiates channel closure if the Lower Tester rejects the IUT configure request for Basic Mode.

- Reference

[1] 4.4, 4.5, 5.4, 6.1.4, 7.1

- Initial Condition
 - The Lower Tester has determined which Enhanced L2CAP Mode the IUT supports (using the Information Request/Response [Extended Features] mechanism). If the IUT supports both, the Lower Tester attempts to configure ERTM.
 - The channel connection has completed.
- Test Procedure

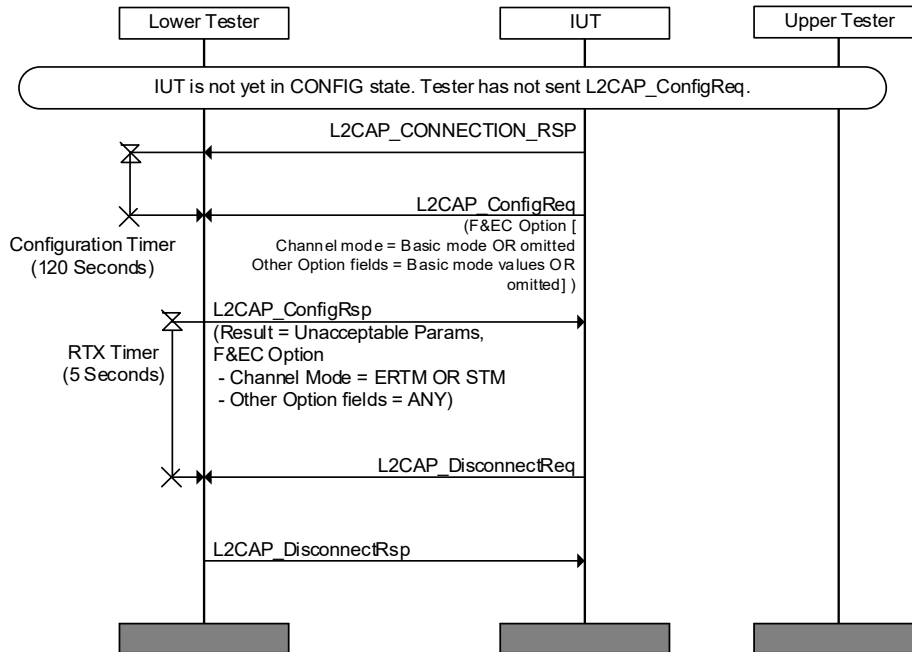

Figure 4.59: L2CAP/CMC/BI-06-C [Configuration to Basic Mode Rejected by the Lower Tester] MSC

- Expected Outcome

Pass verdict

The IUT initiates closure of the channel when it receives the Configure Response rejecting Basic Mode from the Lower Tester.

L2CAP/CMC/BV-10-C [ERTM Not Supported by Lower Tester for Optional ERTM Channel]

- Test Purpose

The IUT is initiating connection of an L2CAP channel that can optionally support use of ERTM. Verify that the IUT attempts to configure Basic Mode if the Lower Tester does not indicate support for ERTM in the Information Response [Extended Features].
- Reference

[1] 4.4, 4.5, 4.10, 4.11, 4.12, 5.4, 6.1.4, 7.1
- Initial Condition
 - An ACL connection has been established by the Lower Tester.



- Test Procedure

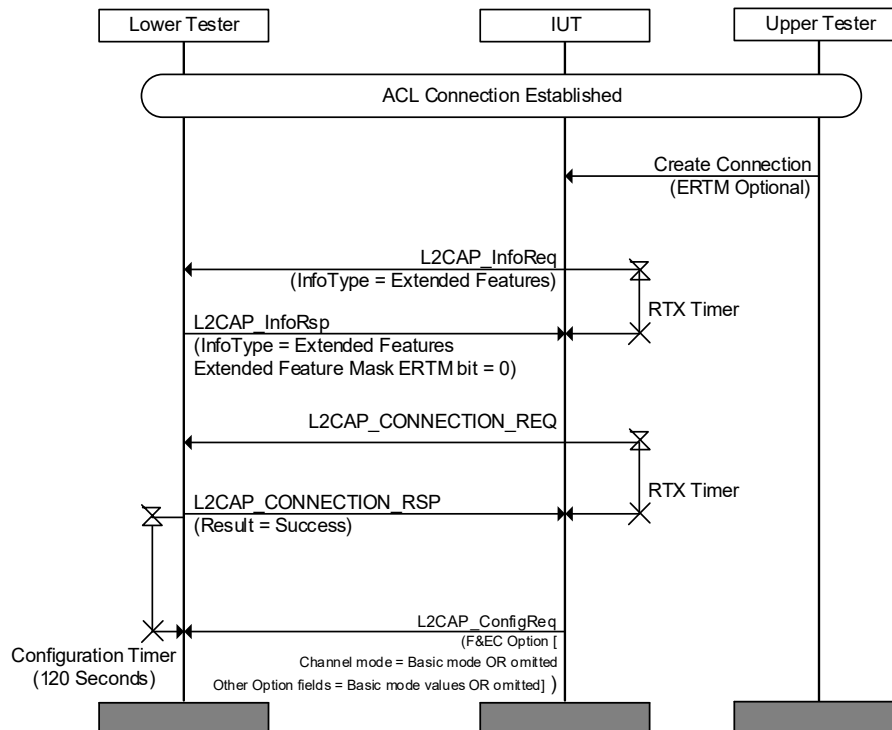

Figure 4.60: L2CAP/CMC/BV-10-C [ERTM Not Supported by Lower Tester for Optional ERTM Channel] MSC

- Expected Outcome

Pass verdict

The IUT sends an L2CAP Information Request for the Extended Features of the Lower Tester.
 The IUT opens the L2CAP channel to the Lower Tester.
 The IUT attempts to configure the channel to Basic Mode.

L2CAP/CMC/BV-11-C [Streaming Mode not supported by Lower Tester for Optional Streaming Mode Channel]

- Test Purpose

The IUT is initiating connection of an L2CAP channel that can optionally support use of STM. Verify that the IUT attempts to configure Basic Mode if the Lower Tester does not indicate support for STM in the Information Response [Extended Features].

- Reference

[1] 4.4, 4.5, 4.10, 4.11, 4.12, 5.4, 6.1.4, 7.1

- Initial Condition

- An ACL connection has been established by the Lower Tester

- Test Procedure

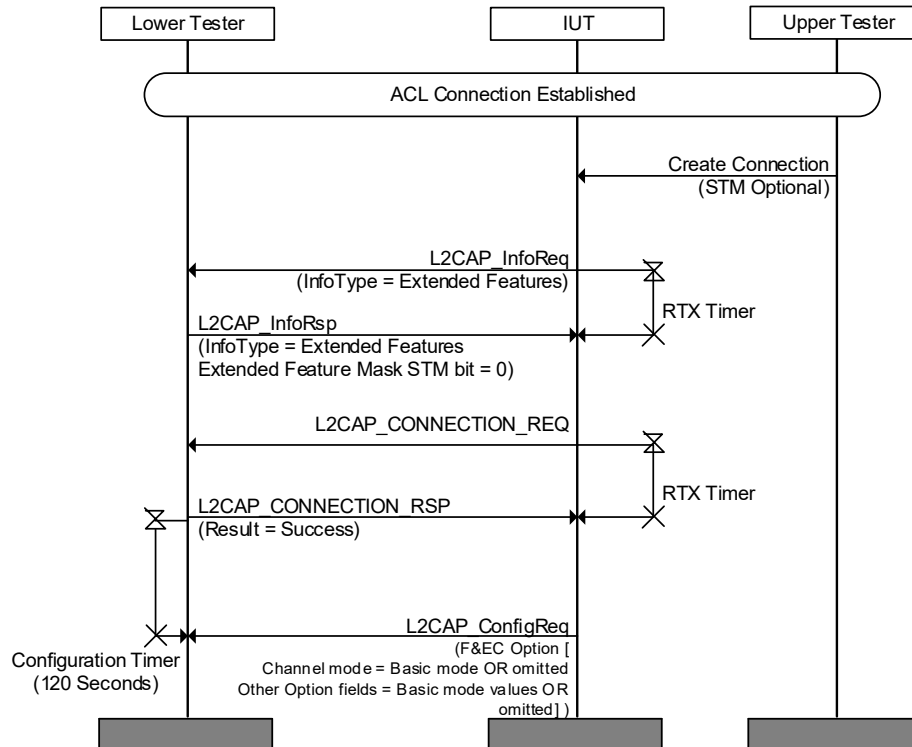

Figure 4.61: L2CAP/CMC/BV-11-C [Streaming Mode not supported by Lower Tester for Optional Streaming Mode Channel] MSC

- Expected Outcome

Pass verdict

The IUT sends an L2CAP Information Request for the Extended Features of the Lower Tester.

The IUT opens the L2CAP channel to the Lower Tester.

The IUT attempts to configure the channel to Basic Mode.

L2CAP/CMC/BV-12-C [ERTM Not Supported by Lower Tester for Mandatory ERTM channel]

- Test Purpose

The IUT is initiating connection of an L2CAP channel that mandates use of ERTM. Verify that the IUT does not attempt to configure the connection to ERTM if the Lower Tester has not indicated support for ERTM in the Information Response [Extended Features].

- Reference

[1] 4.4, 4.5, 4.10, 4.11, 4.12, 5.4, 6.1.4, 7.1

- Initial Condition

- An ACL connection has been established by the Lower Tester.

- Test Procedure

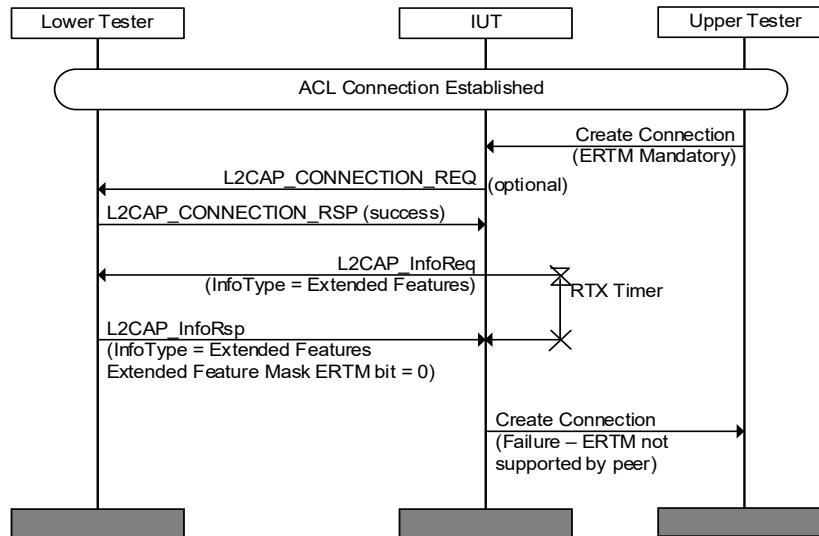

Figure 4.62: L2CAP/CMC/BV-12-C [ERTM Not Supported by Lower Tester for Mandatory ERTM channel] MSC

- Expected Outcome

Pass verdict

The IUT sends an L2CAP Information Request for the Extended Features of the Lower Tester.

The IUT does not attempt to configure the connection to the unsupported mode of the Lower Tester and informs the Upper Tester that the connection has failed.

L2CAP/CMC/BV-13-C [Streaming Mode not supported by Lower Tester for Mandatory Streaming Mode Channel]

- Test Purpose

The IUT is initiating connection of an L2CAP channel that mandates use of STM. Verify that the IUT does not attempt to configure the connection to STM if the Lower Tester has not indicated support for STM in the Information Response [Extended Features].

- Reference

[1] 4.4, 4.5, 4.10, 4.11, 4.12, 5.4, 6.1.4, 7.1

- Initial Condition

- An ACL connection has been established by the Lower Tester.

- Test Procedure

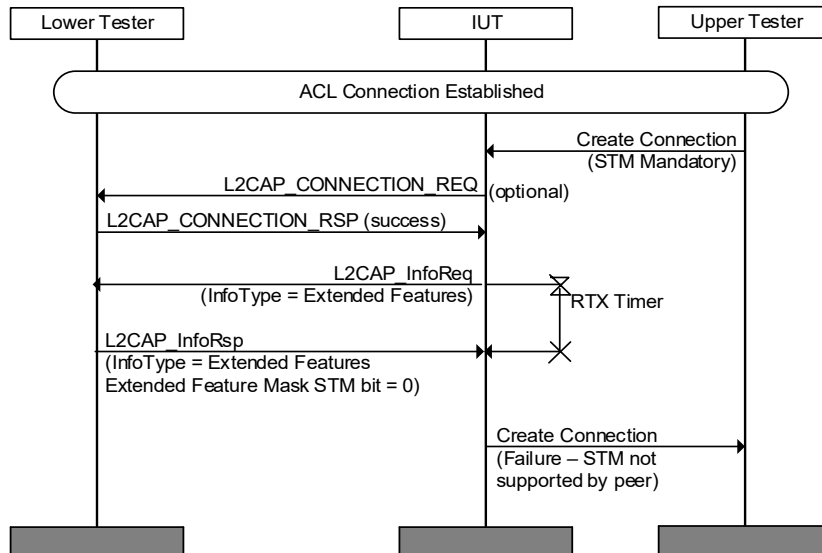

Figure 4.63: L2CAP/CMC/BV-13-C [Streaming Mode not supported by Lower Tester for Mandatory Streaming Mode Channel] MSC

- Expected Outcome

Pass verdict

The IUT sends an L2CAP Information Request for the Extended Features of the Lower Tester.

The IUT does not attempt to configure the connection to the unsupported mode of the Lower Tester and informs the Upper Tester that the connection has failed.

L2CAP/CMC/BV-14-C [Failed Configuration of Streaming Mode when use of the mode is optional and ERTM is proposed by the Lower Tester]

- Test Purpose

When configuring a PSM that can optionally support Streaming Mode, verify that the IUT can handle receipt (renegotiate the channel mode in accordance with the specification) of a Configure Response indicating the peer L2CAP entity wishes to use ERTM (Configure Response Result = Reject Unacceptable Parameters).

- Reference

[1] 4.4, 4.5, 5.4, 6.1.4, 7.1

- Initial Condition

- The IUT has established that the peer L2CAP entity supports Streaming Mode (using the Information Request/Response [Extended Features] mechanism).
- The channel connection has completed.

- Test Procedure

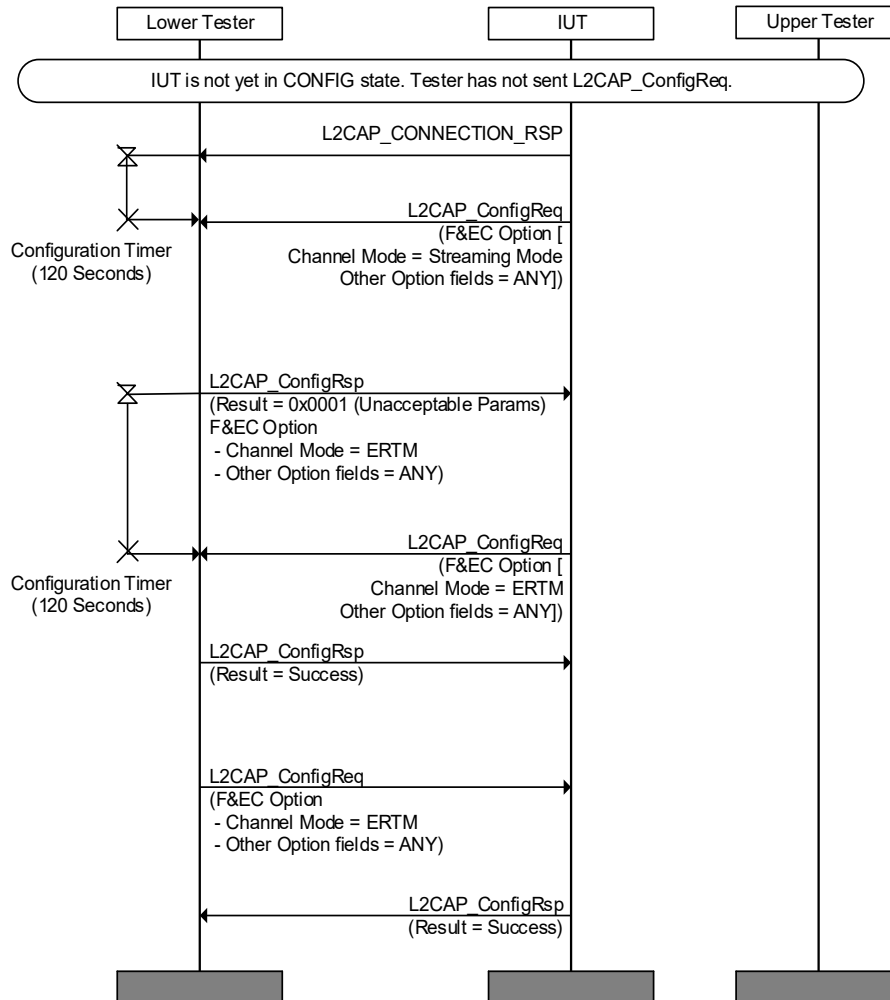

Figure 4.64: L2CAP/CMC/BV-14-C [Failed Configuration of Streaming Mode when use of the mode is optional and ERTM is proposed by the Lower Tester] MSC

- Expected Outcome

Pass verdict

The channel is successfully configured to Enhanced Retransmission Mode.

L2CAP/CMC/BV-15-C [Configuration Mode Mismatch when use of Streaming Mode is Optional and ERTM is proposed by the Lower Tester]

- Test Purpose

When configuring a PSM that can optionally support the use of Streaming Mode, verify that the IUT renegotiates the channel mode to ERTM if the Lower Tester attempts to configure ERTM.

- Reference

[1] 4.4, 4.5, 5.4, 6.1.4, 7.1

- Initial Condition
 - The IUT has established that the peer L2CAP entity supports Streaming Mode (using the Information Request/Response [Extended Features] mechanism).
 - The channel connection has completed.
- Test Procedure

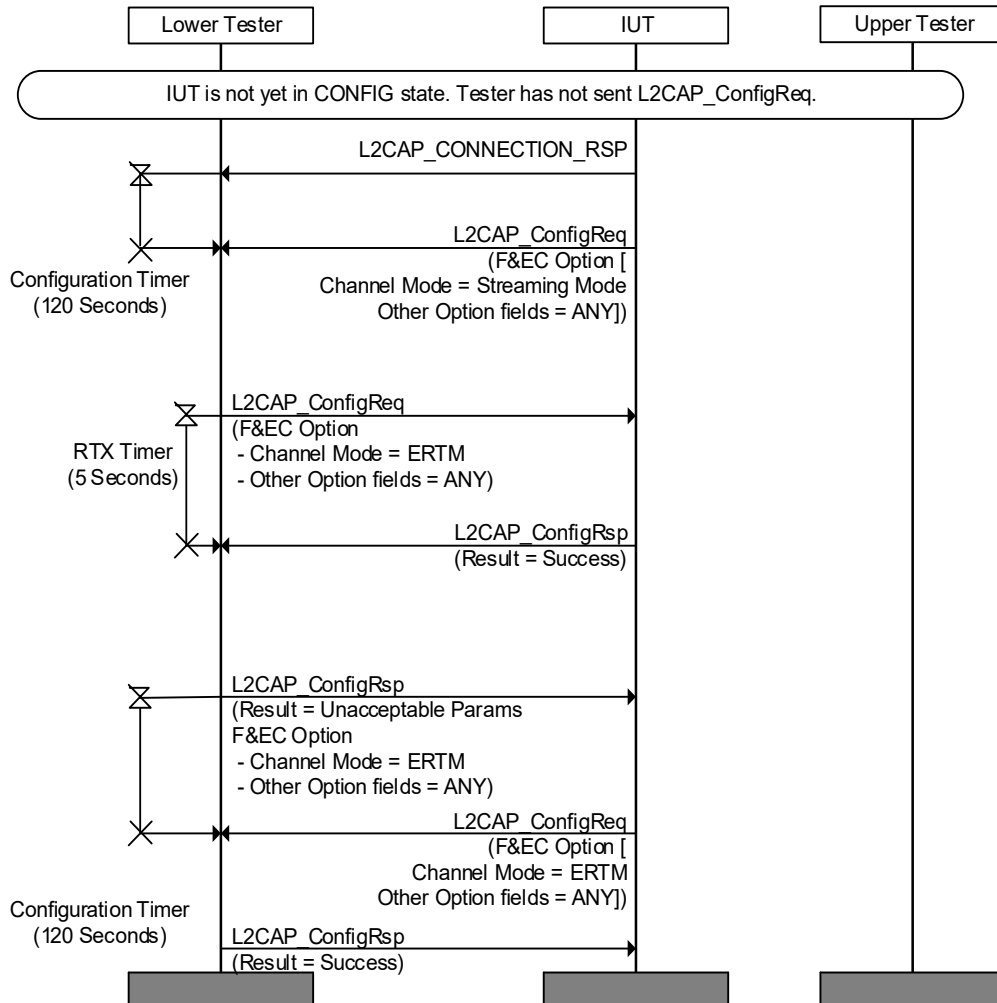

Figure 4.65: L2CAP/CMC/BV-15-C [Configuration Mode Mismatch when use of Streaming Mode is Optional and ERTM is proposed by the Lower Tester] MSC

- Expected Outcome

Pass verdict

The channel is successfully configured to Enhanced Retransmission Mode.

4.5.5 Frame Check Sequence (FCS) Option Configuration (FOC)

Verify the configuration of the FCS option of the L2CAP layer.

4.5.5.1 IUT Initiated Configuration of the FCS Option, IUT No FCS

- Test Purpose

Verify that an IUT that does not support FCS sends S-frame or I-frame PDUs with or without FCS depending on the Lower Tester FCS support.

- Reference

[1] 4.4, 4.5, 5.5, 6.1.4, 7.1

- Initial Condition

- The initiator IUT has established that the peer L2CAP entity supports configuration of the Optional FCS option (using the Information Request/Response [Extended Features] mechanism).

- Test Case Configuration

Test Case	FCS Type (Lower Tester)	IUT S/I-Frame FCS
L2CAP/FOC/BV-01-C [IUT Initiated Configuration of the FCS Option, IUT No FCS Option, Lower Tester No FCS Option]	0x00: No FCS	No
L2CAP/FOC/BV-02-C [IUT Initiated Configuration of the FCS Option, IUT No FCS Option, Lower Tester Yes FCS Option]	0x01: 16-bit FCS	Yes
L2CAP/FOC/BV-03-C [IUT Initiated Configuration of the FCS Option, IUT No FCS Option, Lower Tester Omitted FCS Option]	Omitted	Yes

Table 4.20: IUT Initiated Configuration of the FCS Option, IUT No FCS test cases

- Test Procedure

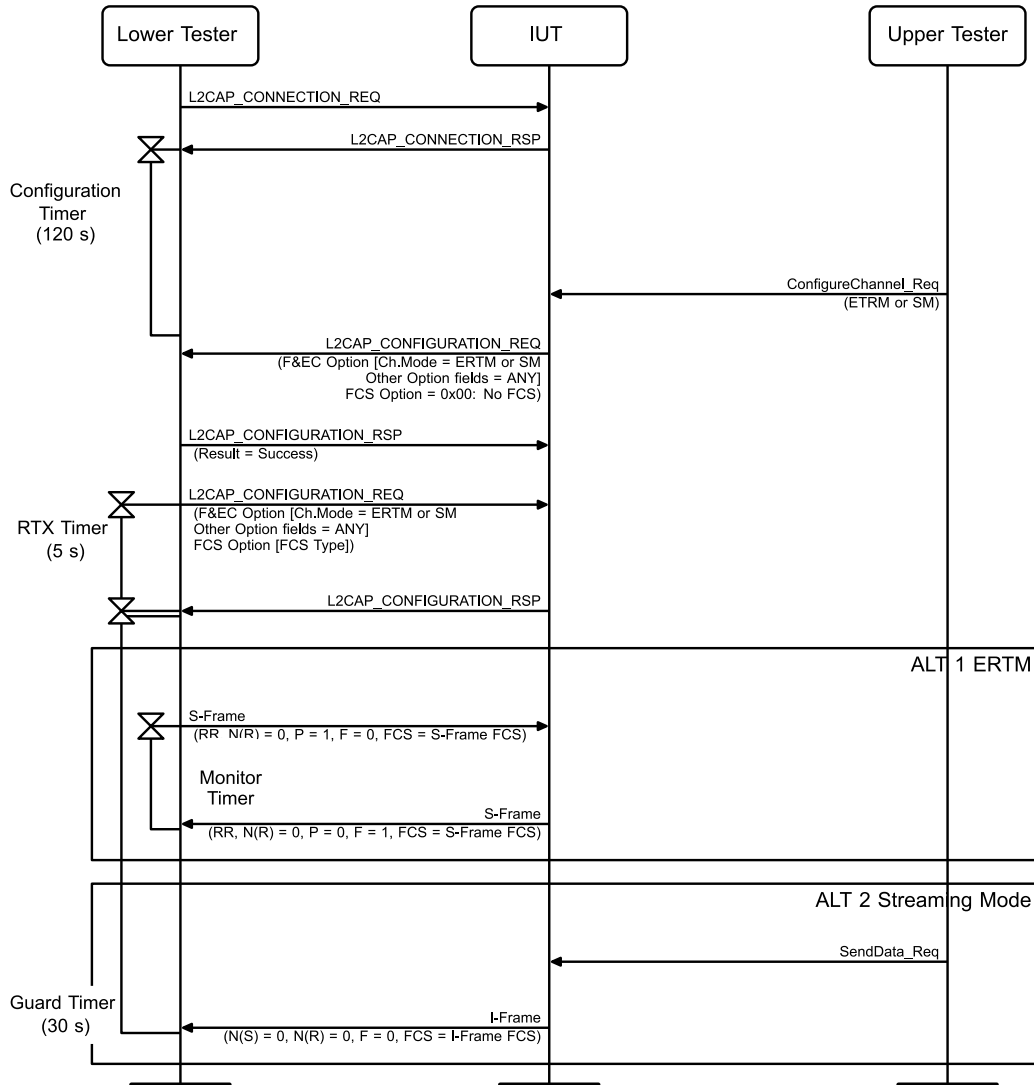

Figure 4.66: IUT Initiated Configuration of the FCS Option, IUT No FCS MSC

- Expected Outcome

Pass verdict

The channel is established.

The IUT sends an S-frame (in response to the S-frame [POLL] from the sender) or an I-frame with or without the FCS field as specified in [Table 4.20](#).

4.5.5.2 IUT Initiated Configuration of the FCS Option, IUT FCS or Omitted

- Test Purpose

Verify that the IUT sends I/S-frames with the FCS field present when the IUT either supports or omits the FCS type and the Lower Tester supports, does not support, or omits the FCS Type.

- Reference

[1] 4.4, 4.5, 5.5, 6.1.4, 7.1

- Initial Condition

- The initiator IUT has established that the peer L2CAP entity supports configuration of the Optional FCS option (using the Information Request/Response [Extended Features] mechanism).

- Test Case Configuration

Test Case	FCS Type (IUT)
L2CAP/FOC/BV-04-C [IUT Initiated Configuration of the FCS Option, IUT FCS 0x01]	0x01: 16-bit FCS
L2CAP/FOC/BV-06-C [IUT Initiated Configuration of the FCS Option, IUT FCS Omitted]	Omitted

Table 4.21: IUT Initiated Configuration of the FCS Option, IUT FCS or Omitted test cases

- Test Procedure

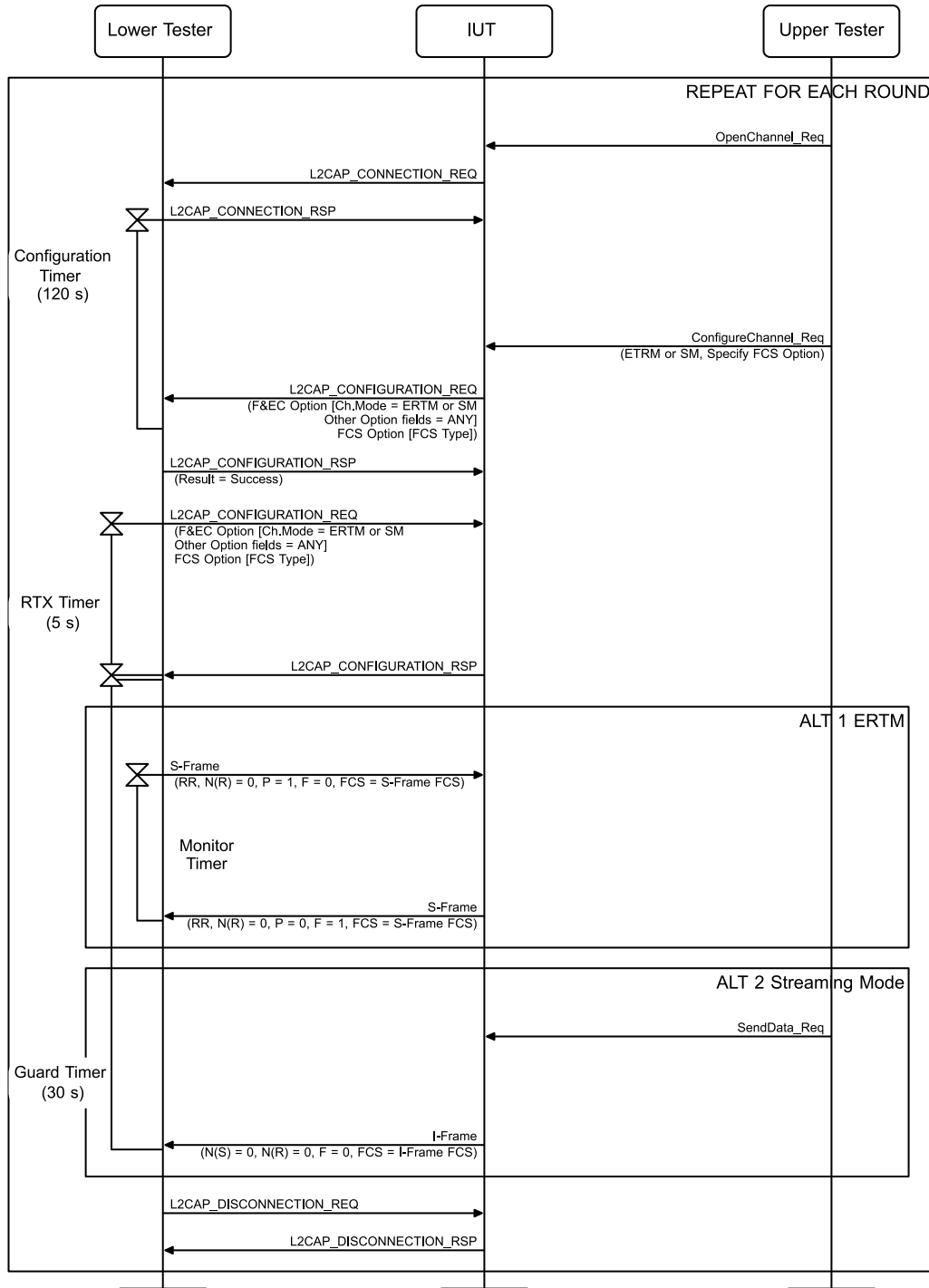

Figure 4.67: IUT Initiated Configuration of the FCS Option, IUT FCS or Omitted MSC

Rounds	FCS Type (Lower Tester)
1	0x00: No FCS
2	0x01: 16-bit FCS
3	Omitted

Table 4.22: IUT Initiated Configuration of the FCS Option, IUT FCS or Omitted rounds

- Expected Outcome

Pass verdict

The channel is established.

The IUT sends an S-frame (in response to the S-frame [POLL] from the sender) or an I-frame with the FCS field present.

4.5.5.3 IUT Responder, Configuration of the FCS Option

- Test Purpose

Verify that the IUT can respond to a channel configuration. The IUT is configured to support, not support, or omit the FCS type as specified in Table 4.24 in I/S-frames and will send I/S-frames with the FCS field as specified in Table 4.24.

- Reference

[1] 4.4, 4.5, 5.5, 6.1.4, 7.1

- Initial Condition

- The responder IUT has established that the peer L2CAP entity supports configuration of the Optional FCS option (using the Information Request/Response [Extended Features] mechanism).

- Test Case Configuration

Test Case	FCS Type (IUT)	IUT S/I-Frame FCS	
		Round 1	Rounds 2 & 3
L2CAP/FOC/BV-05-C [IUT Responder, Configuration of the FCS Option, IUT FCS 0x00]	0x00: No FCS	No	Yes
L2CAP/FOC/BV-07-C [IUT Responder, Configuration of the FCS Option, IUT FCS 0x01]	0x01: 16-bit FCS	Yes	Yes
L2CAP/FOC/BV-08-C [IUT Responder, Configuration of the FCS Option, IUT FCS Omitted]	Omitted	Yes	Yes

Table 4.23: IUT Responder, Configuration of the FCS Option test cases

- Test Procedure

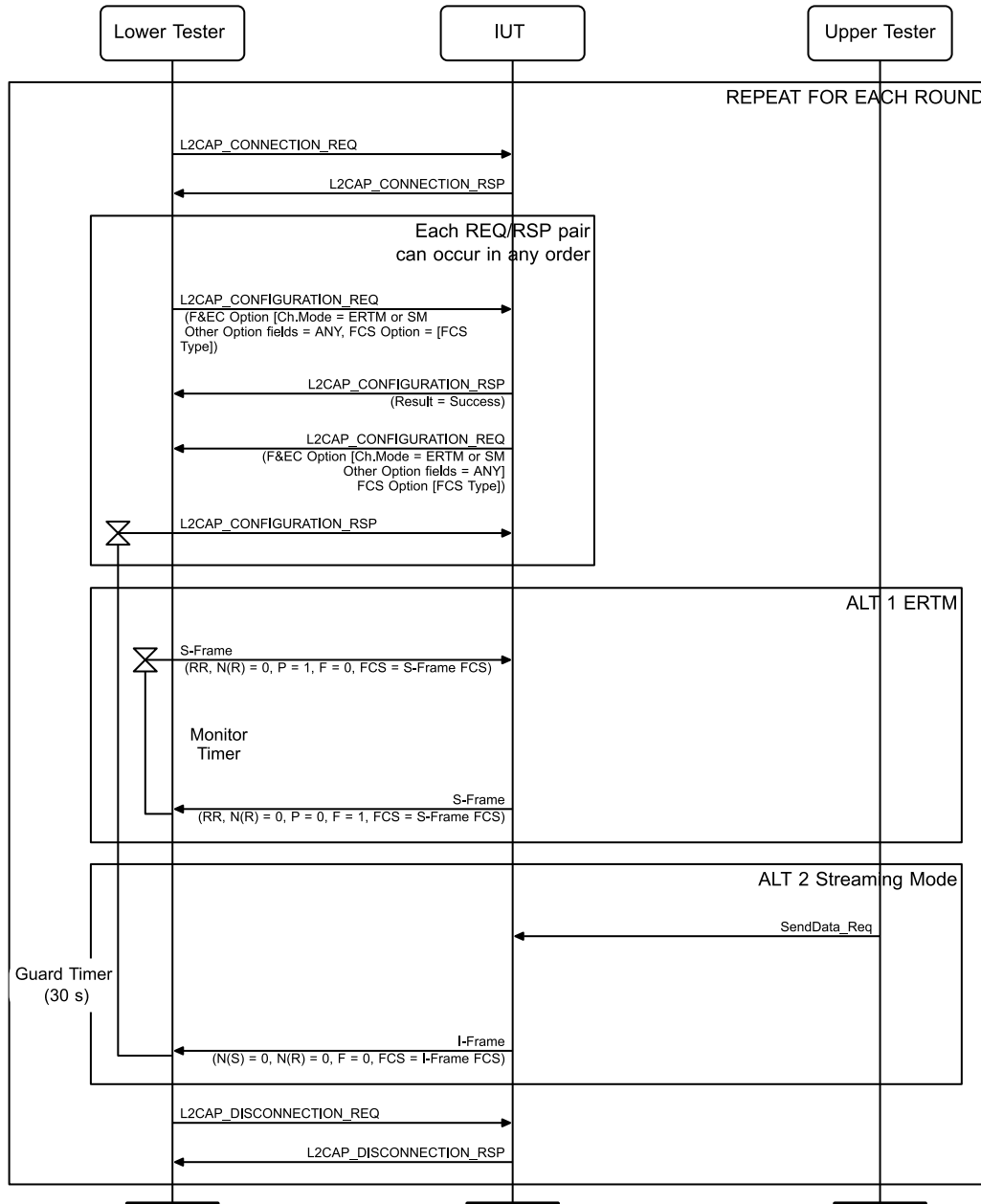

Figure 4.68: IUT Responder, Configuration of the FCS Option MSC

Rounds	FCS Type (Lower Tester)
1	0x00: No FCS
2	0x01: 16-bit FCS
3	Omitted

Table 4.24: IUT Responder, Configuration of the FCS Option rounds



- Expected Outcome

Pass verdict

The channel is established.

The IUT sends an S-frame (in response to the S-frame [POLL] from the sender) or an I-frame with the FCS field as specified in Table 4.24.

4.5.6 Optional FCS (OFS)

Verify the correct implementation of the Optional FCS feature.

L2CAP/OFS/BV-01-C [Sending I-Frames without FCS for ERTM]

- Test Purpose

Verify that the IUT does not include the FCS in I-frames.

- Reference

[1] 3.3.5, 8.6

- Initial Condition

- The channel is configured to not include FCS in I/S-frames.
- The channel is configured to use ERTM.

- Test Procedure

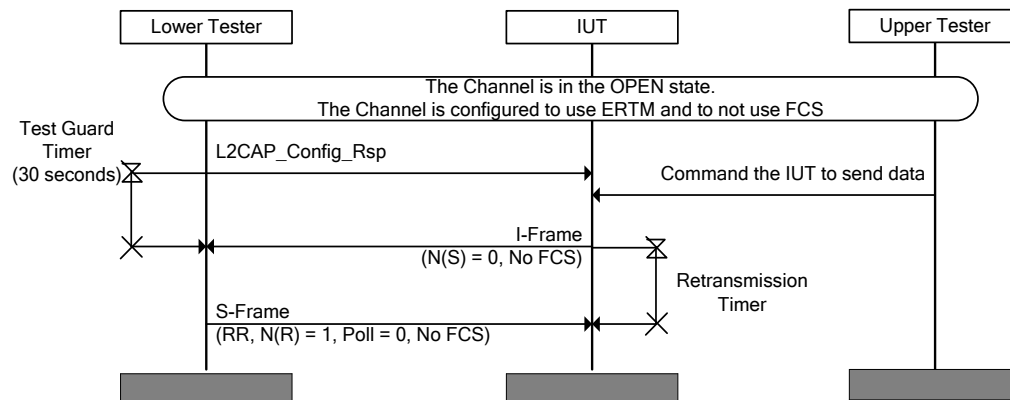

Figure 4.69: L2CAP/OFS/BV-01-C [Sending I-Frames without FCS for ERTM] MSC

- Expected Outcome

Pass verdict

The IUT sends an I-frame without the FCS field.

L2CAP/OFS/BV-02-C [Receiving Frames without FCS for ERTM]

- Test Purpose

Verify that the IUT can handle I-frames that do not contain the FCS.

- Reference

[1] 3.3.5, 8.6

- Initial Condition
 - The channel is configured to not include FCS in I/S-frames.
 - The channel is configured to use ERTM.
- Test Procedure

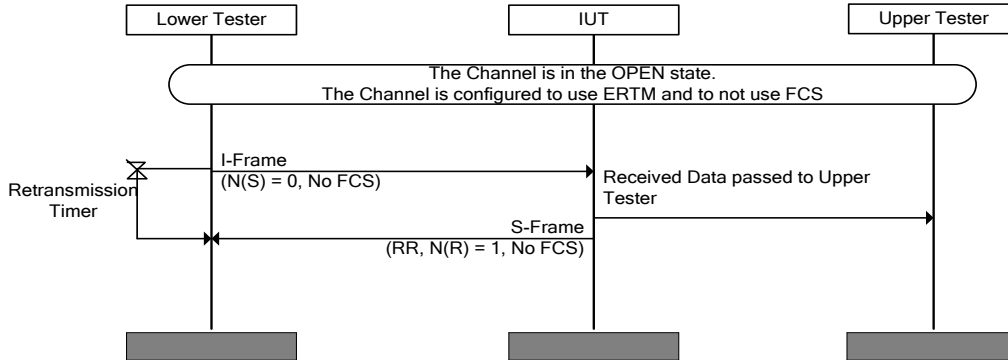

Figure 4.70: L2CAP/OFS/BV-02-C [Receiving Frames without FCS for ERTM] MSC

- Expected Outcome

Pass verdict

The IUT passes the received data to the Upper Tester.

The IUT acknowledges the received I-frame before the Retransmission timer of the Lower Tester expires.

L2CAP/OFS/BV-03-C [Sending I-Frames without FCS for Streaming Mode]

- Test Purpose
 - Verify that the IUT does not include the FCS in I-frames.
- Reference
 - [1] 3.3.5, 8.7
- Initial Condition
 - The channel is configured to not include FCS in I/S-frames.
 - The channel is configured to use Streaming Mode.
- Test Procedure

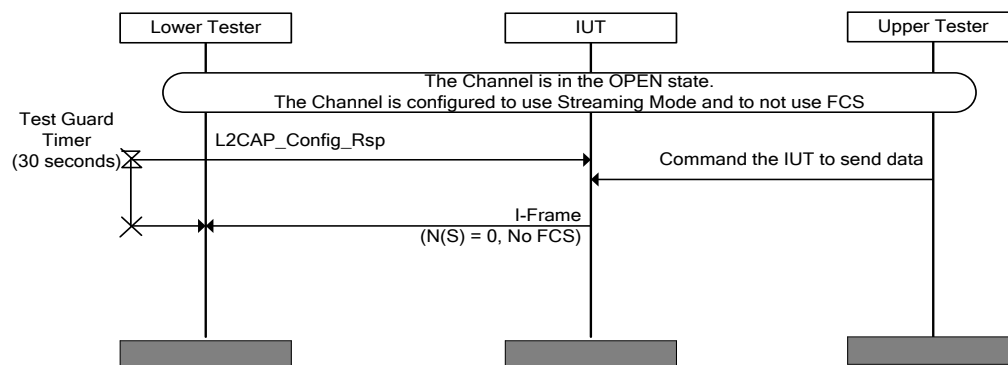

Figure 4.71: L2CAP/OFS/BV-03-C [Sending I-Frames without FCS for Streaming Mode] MSC

- Expected Outcome

Pass verdict

The IUT sends an I-frame without the FCS field.

L2CAP/OFS/BV-04-C [Receiving Frames without FCS for Streaming Mode]

- Test Purpose

Verify that the IUT can handle I-frames that do not contain the FCS.

- Reference

[1] 3.3.5, 8.7

- Initial Condition

- The channel is configured to not include FCS in I/S-frames.
- The channel is configured to use Streaming Mode.

- Test Procedure

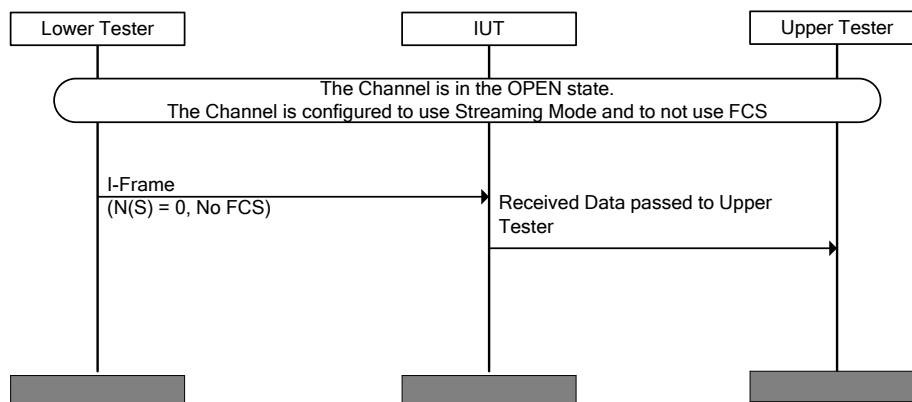

Figure 4.72: L2CAP/OFS/BV-04-C [Receiving Frames without FCS for Streaming Mode] MSC

- Expected Outcome

Pass verdict

The IUT passes the received data to the Upper Tester.

L2CAP/OFS/BV-05-C [Sending I-Frames with FCS for ERTM]

- Test Purpose

Verify that the IUT does include the FCS in I-frames.

- Reference

[1] 3.3.5, 8.6

- Initial Condition

- The channel is configured to include FCS in I/S-frames.
- The channel is configured to use ERTM.

- Test Procedure

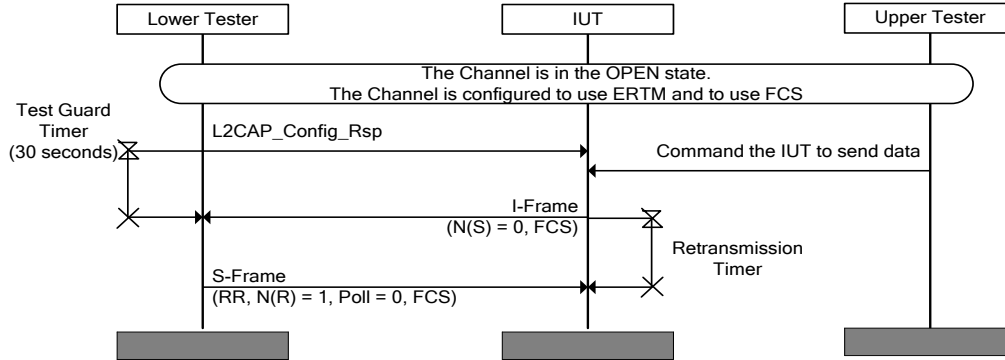

Figure 4.73: L2CAP/OFS/BV-05-C [Sending I-Frames with FCS for ERTM] MSC

- Expected Outcome

Pass verdict

The IUT sends an I-frame with the correct FCS included.

L2CAP/OFS/BV-06-C [Receiving Frames with FCS for ERTM]

- Test Purpose

Verify that the IUT can handle I-frames that do contain the FCS.

- Reference

[1] 3.3.5, 8.6

- Initial Condition

- The channel is configured to include FCS in I/S-frames.
- The channel is configured to use ERTM.

- Test Procedure

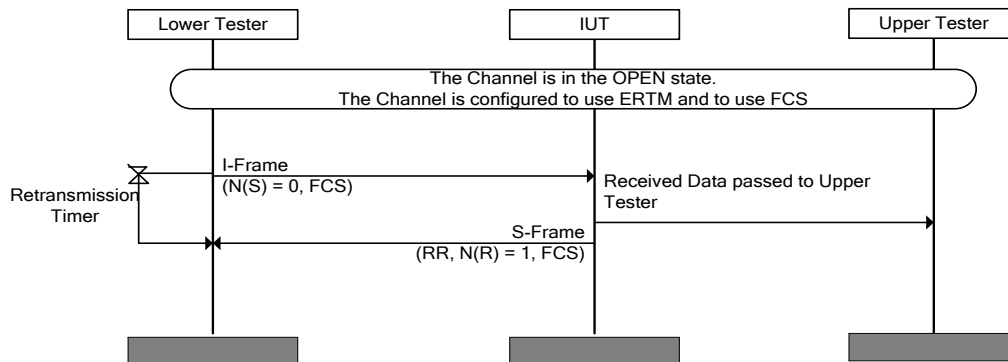

Figure 4.74: L2CAP/OFS/BV-06-C [Receiving Frames with FCS for ERTM] MSC

- Expected Outcome

Pass verdict

The IUT passes the received data to the Upper Tester.

The IUT acknowledges the received I-frame before the Retransmission timer of the Lower Tester expires.

L2CAP/OFS/BV-07-C [Sending I-Frames with FCS for Streaming Mode]

- Test Purpose

Verify that the IUT does include the FCS in I-frames.
- Reference

[1] 3.3.5, 8.7
- Initial Condition
 - The channel is configured to include FCS in I/S-frames.
 - The channel is configured to use Streaming Mode.
- Test Procedure

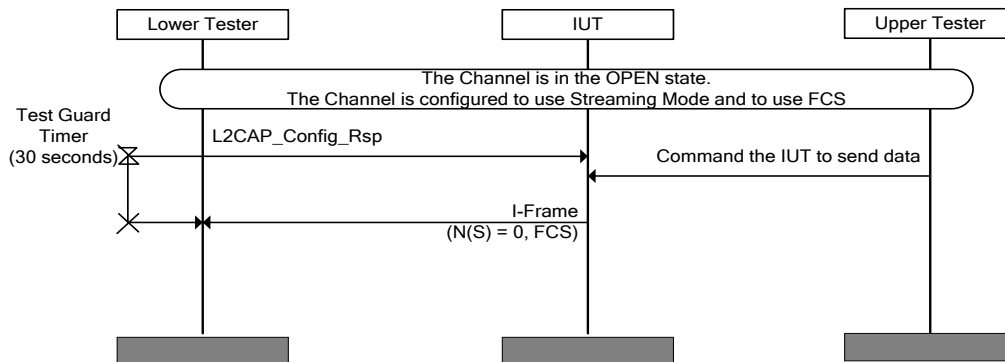

Figure 4.75: L2CAP/OFS/BV-07-C [Sending I-Frames with FCS for Streaming Mode] MSC

- Expected Outcome

Pass verdict

The IUT sends an I-frame with the FCS field.

L2CAP/OFS/BV-08-C [Receiving Frames with FCS for Streaming Mode]

- Test Purpose

Verify that the IUT can handle I-frames that do contain the FCS.
- Reference

[1] 3.3.5, 8.7
- Initial Condition
 - The channel is configured to include FCS in I/S-frames.
 - The channel is configured to use Streaming Mode.

- Test Procedure

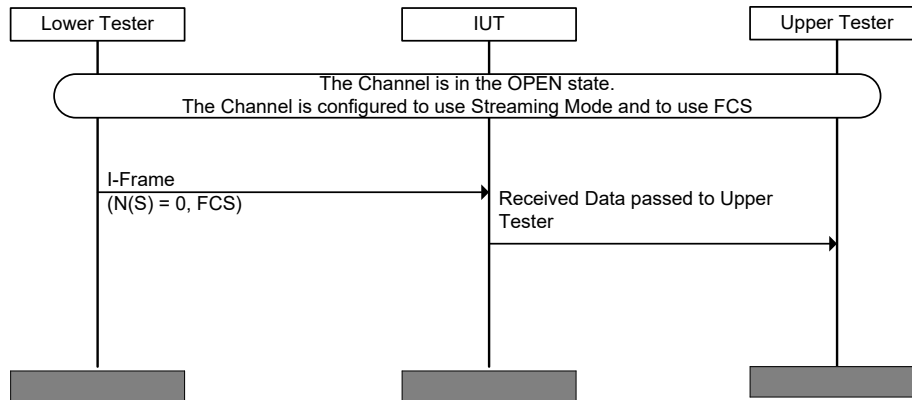

Figure 4.76: L2CAP/OFS/BV-08-C [Receiving Frames with FCS for Streaming Mode] MSC

- Expected Outcome

Pass verdict

The IUT passes the received data to the Upper Tester.

4.5.7 Enhanced Retransmission Mode (ERM)

Verify the correct implementation of the Enhanced Retransmission Mode of L2CAP.

L2CAP/ERM/BV-01-C [Transmit I-frames]

- Test Purpose

Verify that the IUT can send correctly formatted sequential I-frames with valid values for the enhanced control fields (SAR, F-bit, ReqSeq, TxSeq).

- Reference

[1] 3.3.2, 8.6

- Initial Condition

- The IUT is in the INFO_TRANSFER state for a data channel with assigned CID.
- The connection is configured as ERTM.
- I(out) outgoing I-frames and I(in) incoming I-frames have been sent and received by the IUT over the channel after it was opened and before the test is executed.

- Test Procedure

Figure 4.77 assumes I(out) and I(in) are 0. The actual values of N(S) and N(R) for both incoming and outgoing traffic must take the number of previously sent and received I-frames into account.

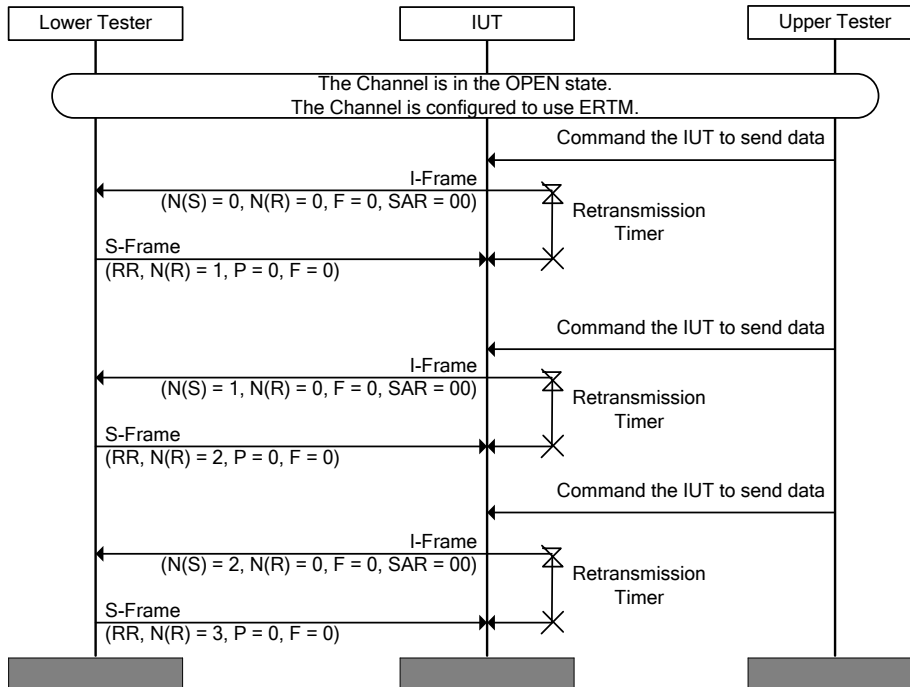

Figure 4.77: L2CAP/ERM/BV-01-C [Transmit I-frames] MSC

- Expected Outcome

Pass verdict

The IUT sends I-frame(s) to the Lower Tester.

Data in the I-frame(s) match that provided by the Upper Tester.

SAR bits are set per the Specification in [8].

F-bit is set to 0.

L2CAP/ERM/BV-02-C [Receive I-Frames]

- Test Purpose

Verify that the IUT can receive in-sequence valid I-frames and deliver L2CAP SDUs to the Upper Tester.

- Reference

[1] 3.3.2, 8.6

- Initial Condition

- The IUT is in the INFO_TRANSFER state for a data channel with assigned CID.
- The connection is configured as ERTM.

- I(out) outgoing I-frames and I(in) incoming I-frames have been sent and received by the IUT over the channel after it was opened and before the test is executed.
- The IUT has configured an MPS size that is equal to 48 bytes.

• Test Procedure

Figure 4.78 assumes I(out) and I(in) are 0. The actual values of N(S) and N(R) for both incoming and outgoing traffic must take the number of previously sent and received I-frames into account.

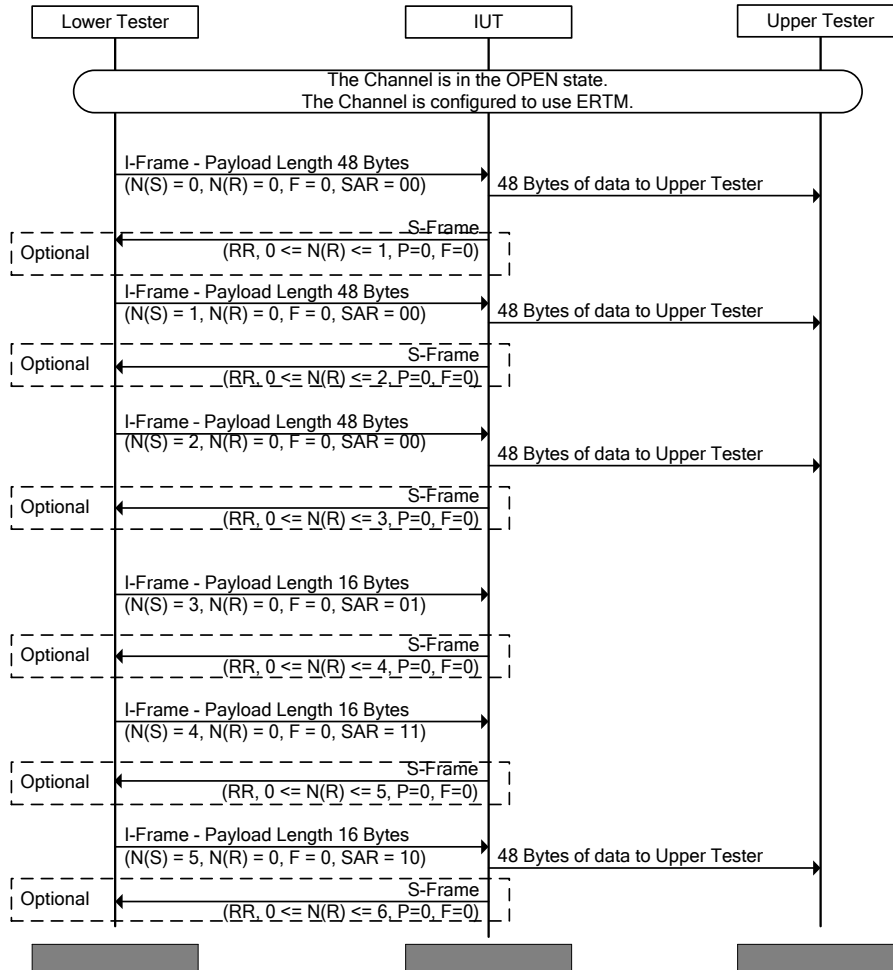

Figure 4.78: L2CAP/ERM/BV-02-C [Receive I-Frames] MSC

• Expected Outcome

Pass verdict

Data in the received I-frame(s) match that sent by the Lower Tester.

SAR bits are set per specification.

F-bit is set to 0.

Complete SDU is sent to the Upper Tester.

L2CAP/ERM/BV-03-C [Acknowledging Received I-Frames]

- Test Purpose

Verify that the IUT sends S-frame [RR] with the Poll bit not set to acknowledge data received from the Lower Tester.

- Reference

[1] 3.3.2, 8.6.1.1

- Initial Condition

- The IUT is in the INFO_TRANSFER state for a data channel with assigned CID. The connection is configured as ERTM.
- I(out) outgoing I-frames and I(in) incoming I-frames have been sent and received by the IUT over the channel after it was opened and before the test is executed.

- Test Procedure

Figure 4.79 assumes I(out) and I(in) are 0. The actual values of N(S) and N(R) for both incoming and outgoing traffic must take the number of previously sent and received I-frames into account.

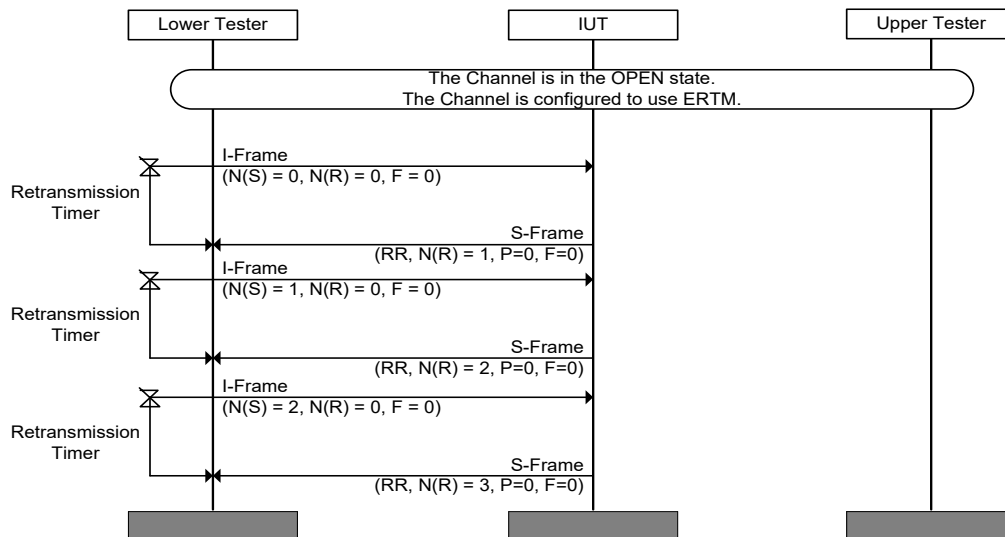

Figure 4.79: L2CAP/ERM/BV-03-C [Acknowledging Received I-Frames] MSC

- Expected Outcome

Pass verdict

The IUT sends a Supervisory Frame with S=RR, LastAkedReqSeq < ReqSeq <= last received I-frame's TxSeq+1, F=0, P=0, Reserved bits = 0.

L2CAP/ERM/BV-05-C [Resume Transmitting I-Frames when an S-Frame [RR] is Received]

- Test Purpose

Verify that the IUT ceases transmission of I-frames when the negotiated TxWindow is full. Verify that the IUT resumes transmission of I-frames when an S-frame [RR] is received that acknowledges previously sent I-frames.

- Reference

[1] 3.3.2, 8.6.4



- Initial Condition
 - The IUT is in the INFO_TRANSFER state for a data channel with assigned CID. The connection is configured as ERTM.
 - I(out) outgoing I-frames and I(in) incoming I-frames have been sent and received by the IUT over the channel after it was opened and before the test is executed.
 - The Lower Tester specifies a TxWindow size of 1 in the Configuration Request it sends to the IUT.
- Test Procedure

Figure 4.80 assumes I(out) and I(in) are 0. The actual values of N(S) and N(R) for both incoming and outgoing traffic must take the number of previously sent and received I-frames into account.

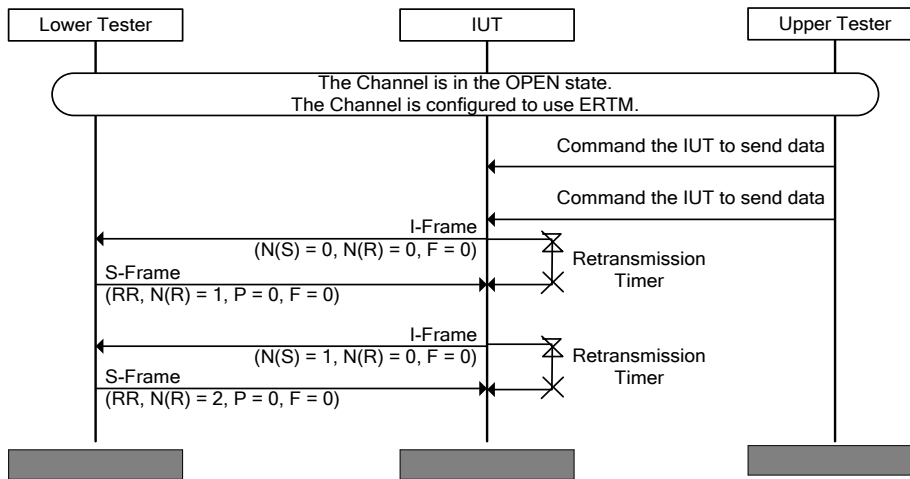

Figure 4.80: L2CAP/ERM/BV-05-C [Resume Transmitting I-Frames when an S-Frame [RR] is Received] MSC

- Expected Outcome

Pass verdict

The IUT sends I-frames until TxWindow is full.

The IUT does not send any I-frame when the TxWindow is full.

The IUT sends the outstanding I-frame when it receives the acknowledgment of the first I-frame from the Lower Tester.

L2CAP/ERM/BV-06-C [Resume Transmitting I-Frames when an I-Frame is Received]

- Test Purpose

Verify that the IUT ceases transmission of I-frames when the negotiated TxWindow is full. Verify that the IUT resumes transmission of I-frames when an I-frame is received that acknowledges previously sent I-frames.

- Reference

[1] 3.3.2, 8.6.4

- Initial Condition
 - The IUT is in the INFO_TRANSFER state for a data channel with assigned CID. The connection is configured as ERTM.
 - I(out) outgoing I-frames and I(in) incoming I-frames have been sent and received by the IUT over the channel after it was opened and before the test is executed.
 - The Lower Tester specifies a TxWindow size of 1 in the Configuration Request it sends to the IUT.
- Test Procedure

Figure 4.81 assumes I(out) and I(in) are 0. The actual values of N(S) and N(R) for both incoming and outgoing traffic must take the number of previously sent and received I-frames into account.

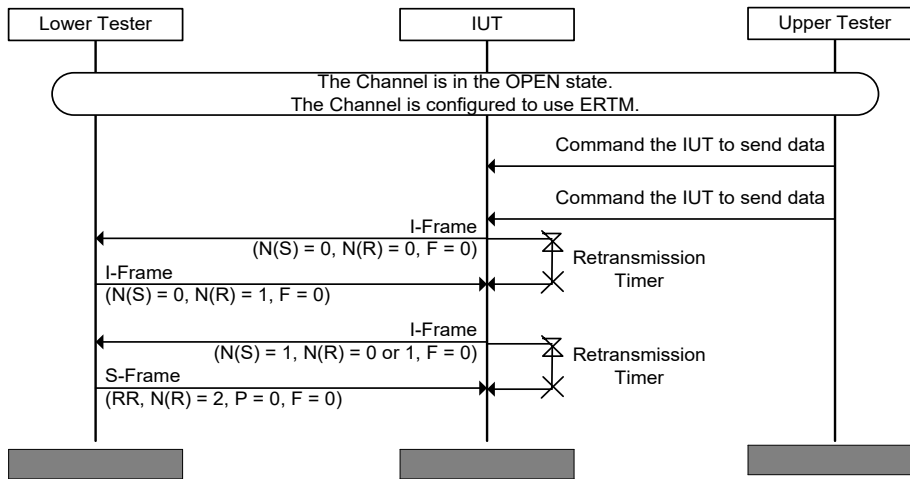

Figure 4.81: L2CAP/ERM/BV-06-C [Resume Transmitting I-Frames when an I-Frame is Received] MSC

- Expected Outcome

Pass verdict

The IUT sends I-frames until TxWindow is full.

The IUT does not send any I-frame when the TxWindow is full.

The IUT sends the outstanding I-frame when it receives the acknowledgment of the first I-frame from the Lower Tester.

L2CAP/ERM/BV-07-C [Send S-Frame [RNR]]

- Test Purpose
 - Verify that the IUT sends an S-frame [RNR] when it detects a Local Busy condition.
- Reference
 - [1] 3.3.2, 8.6.1.3, 8.6.4
- Initial Condition
 - The channel is in the OPEN state and configured to use ERTM.
 - I(out) outgoing I-frames and I(in) incoming I-frames have been sent and received by the IUT over the channel after it was opened and before the test is executed.

- Whether the IUT has the capability to set the Local Busy condition from the Upper Tester is specified in the L2CAP TSPX_generate_local_busy IXIT value.

- Test Procedure

Figure 4.82 assumes I(out) and I(in) are 0. The actual values of N(S) and N(R) for both incoming and outgoing traffic must take the number of previously sent and received I-frames into account.

The Lower Tester sends as many I-frames as are permitted by the IUT TxWindow to trigger the Local Busy condition at the IUT. Once the Lower Tester receives the RNR from the IUT it will stop sending I-frames.

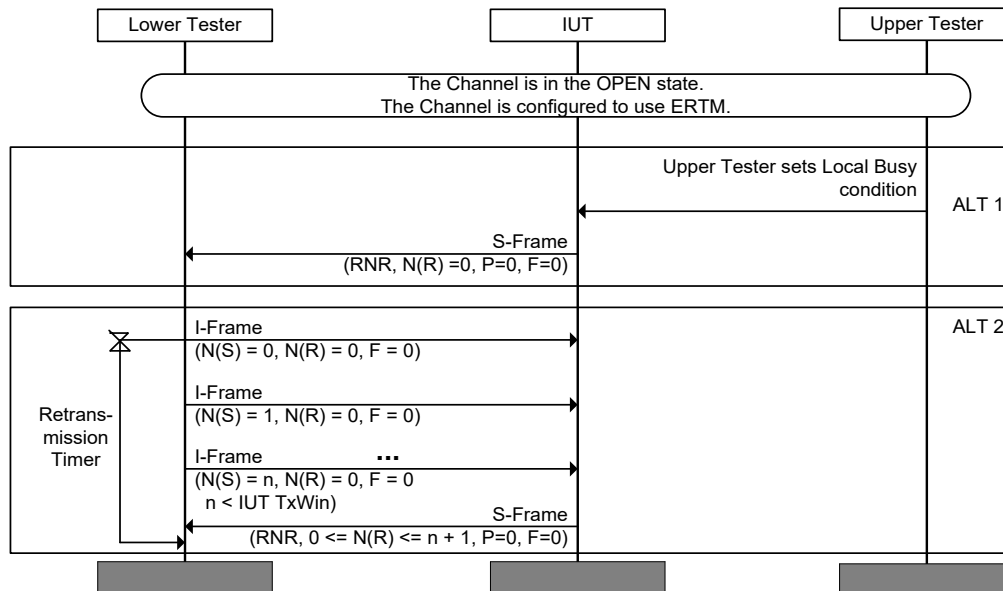

Figure 4.82: L2CAP/ERM/BV-07-C [Send S-Frame [RNR]] MSC

- Expected Outcome

Pass verdict

ALT 1: The IUT immediately sends an S-frame with function RNR after the Local Busy condition is set by the Upper Tester.

ALT 2: The IUT sends an S-frame with function RNR after receiving I-frame(s) from the Lower Tester when the Local Busy condition is reached.

L2CAP/ERM/BV-08-C [Send S-Frame [RR] with Poll Bit Set]

- Test Purpose

Verify that the IUT sends an S-frame [RR] with the Poll bit set when its retransmission timer expires.

- Reference

[1] 3.3.2, 8.6.1.4, 8.6.4

- Initial Condition

- The channel is in the OPEN state and configured to use ERTM.
- I(out) outgoing I-frames and I(in) incoming I-frames have been sent and received by the IUT over the channel after it was opened and before the test is executed.

- Test Procedure

Figure 4.83 assumes $I(\text{out})$ and $I(\text{in})$ are 0. The actual values of $N(S)$ and $N(R)$ for both incoming and outgoing traffic must take the number of previously sent and received I-frames into account.

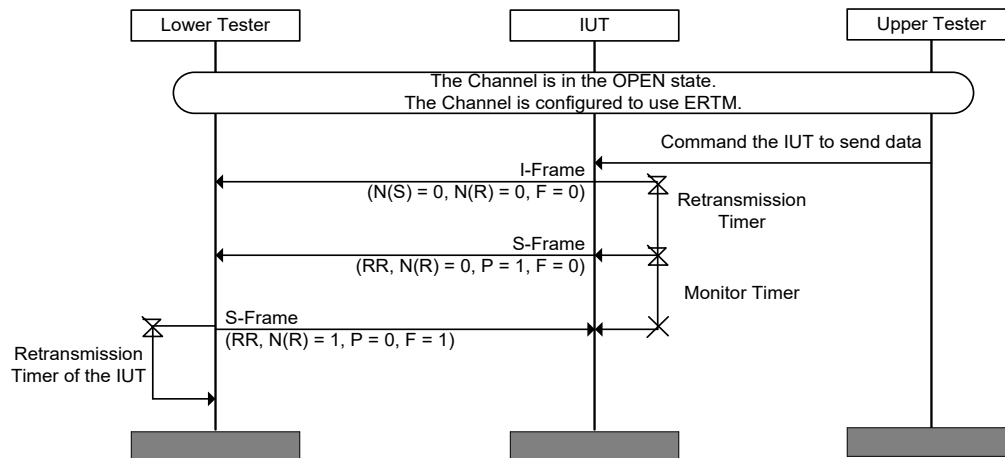

Figure 4.83: L2CAP/ERM/BV-08-C [Send S-Frame [RR] with Poll Bit Set] MSC

- Expected Outcome

Pass verdict

The IUT sends an S-frame with the POLL bit set after the IUT Retransmission Timer (as specified by Lower Tester during configuration) expires.

The IUT does not retransmit the I-frame after receiving an S-frame from the Lower Tester that acknowledges the previously sent I-frame.

L2CAP/ERM/BV-09-C [Send S-frame [RR] with Final Bit Set]

- Test Purpose

Verify that the IUT responds with an S-frame [RR] with the Final bit set after receiving an S-frame [RR] with the Poll bit set.

- Reference

[1] 3.3.2, 8.6.1.4, 8.6.4

- Initial Condition

- The channel is in the OPEN state and configured to use ERTM.
- $I(\text{out})$ outgoing I-frames and $I(\text{in})$ incoming I-frames have been sent and received by the IUT over the channel after it was opened and before the test is executed.

- Test Procedure

Figure 4.84 assumes I(out) and I(in) are 0. The actual values of N(S) and N(R) for both incoming and outgoing traffic must take the number of previously sent and received I-frames into account.

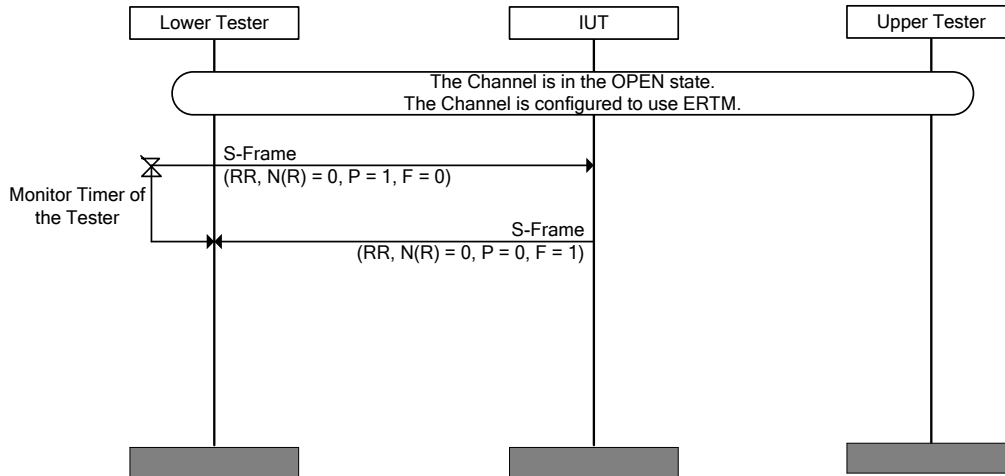

Figure 4.84: L2CAP/ERM/BV-09-C [Send S-frame [RR] with Final Bit Set] MSC

- Expected Outcome

Pass verdict

The IUT sends an S-frame with the Final bit set before the Monitor Timer of the Lower Tester expires.

L2CAP/ERM/BV-10-C [Retransmit S-Frame [RR] with Poll Bit Set]

- Test Purpose

Verify that the IUT will retransmit the S-frame [RR] with the Poll bit set when the Monitor Timer expires.

- Reference

[1] 3.3.2, 8.6.1.4, 8.6.4

- Initial Condition

- The channel is in the OPEN state and configured to use ERTM.
- I(out) outgoing I-frames and I(in) incoming I-frames have been sent and received by the IUT over the channel after it was opened and before the test is executed.
- The MaxTransmit for the IUT is set to a value greater than 1.

- Test Procedure

Figure 4.85 assumes I(out) and I(in) are 0. The actual values of N(S) and N(R) for both incoming and outgoing traffic must take the number of previously sent and received I-frames into account.

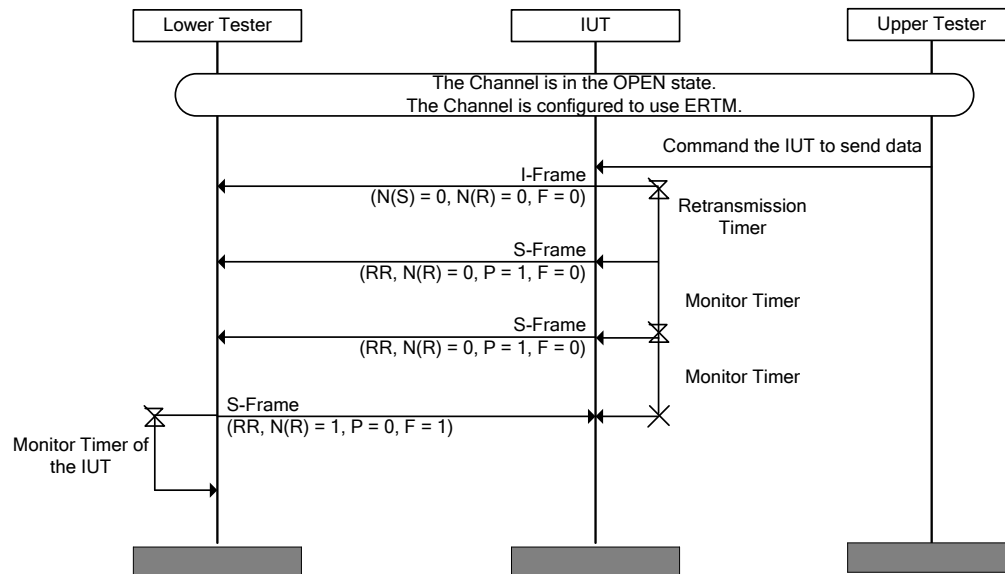

Figure 4.85: L2CAP/ERM/BV-10-C [Retransmit S-Frame [RR] with Poll Bit Set] MSC

- Expected Outcome

Pass verdict

The IUT retransmits the S-frame with the POLL bit set after the Monitor Timer expires.

The IUT does not retransmit the S-frame with the POLL bit set after receiving the S-frame acknowledgment of the previously sent I-frame.

L2CAP/ERM/BV-11-C [S-Frame Transmissions Exceed MaxTransmit]

- Test Purpose

Verify that the IUT closes the channel when the Monitor Timer expires.

- Reference

[1] 3.3.2, 5.4, 8.6.4

- Initial Condition

- The channel is in the OPEN state and configured to use ERTM.
- I(out) outgoing I-frames and I(in) incoming I-frames have been sent and received by the IUT over the channel after it was opened and before the test is executed.
- The MaxTransmit for the IUT is set to 1.

- Test Procedure

Figure 4.86 assumes I(out) and I(in) are 0. The actual values of N(S) and N(R) for both incoming and outgoing traffic must take the number of previously sent and received I-frames into account.

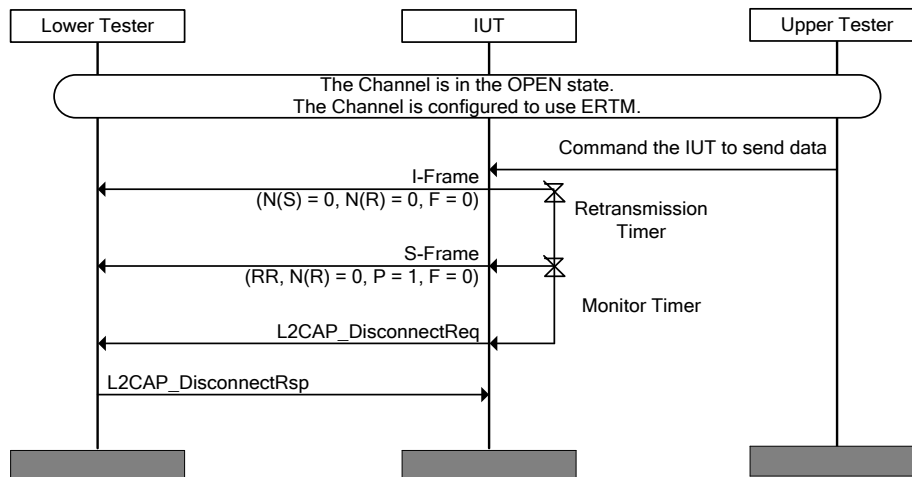

Figure 4.86: L2CAP/ERM/BV-11-C [S-Frame Transmissions Exceed MaxTransmit] MSC

- Expected Outcome

Pass verdict

The IUT initiates closure of the L2CAP channel when the Monitor Timer expires.

L2CAP/ERM/BV-12-C [I-Frame Transmissions Exceed MaxTransmit]

- Test Purpose

Verify that the IUT closes the channel when it receives an S-frame [RR] with the final bit set that does not acknowledge the previous I-frame sent by the IUT.

- Reference

[1] 3.3.2, 5.4, 8.6.4

- Initial Condition

- The channel is in the OPEN state and configured to use ERTM.
- I(out) outgoing I-frames and I(in) incoming I-frames have been sent and received by the IUT over the channel after it was opened and before the test is executed.
- The MaxTransmit for the IUT is set to 1.

- Test Procedure

Figure 4.87 assumes I(out) and I(in) are 0. The actual values of N(S) and N(R) for both incoming and outgoing traffic must take the number of previously sent and received I-frames into account.

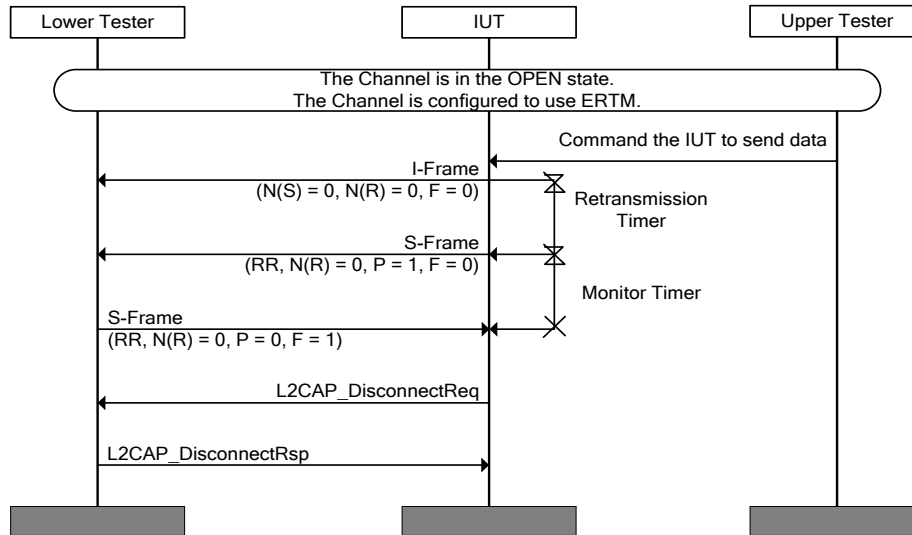

Figure 4.87: L2CAP/ERM/BV-12-C [I-Frame Transmissions Exceed MaxTransmit] MSC

- Expected Outcome

Pass verdict

The IUT initiates closure of the L2CAP channel when it receives the S-frame from the Lower Tester that does not acknowledge the previously sent I-frame.

L2CAP/ERM/BV-13-C [Respond to S-Frame [REJ]]

- Test Purpose

Verify that the IUT retransmits I-frames starting from the sequence number specified in the S-frame [REJ].

- Reference

[1] 3.3.2, 8.6.1.2, 8.6.4

- Initial Condition

- The channel is in the OPEN state and configured to use ERTM.
- I(out) outgoing I-frames and I(in) incoming I-frames have been sent and received by the IUT over the channel after it was opened and before the test is executed.
- The MaxTransmit for the IUT is set to a value greater than 1.
- The Lower Tester has specified a value for TxWin that is greater than 1 in the Configure Request sent to the IUT.

- Test Procedure

Figure 4.88 assumes $I(out)$ and $I(in)$ are 0. The actual values of $N(S)$ and $N(R)$ for both incoming and outgoing traffic must take the number of previously sent and received I-frames into account.

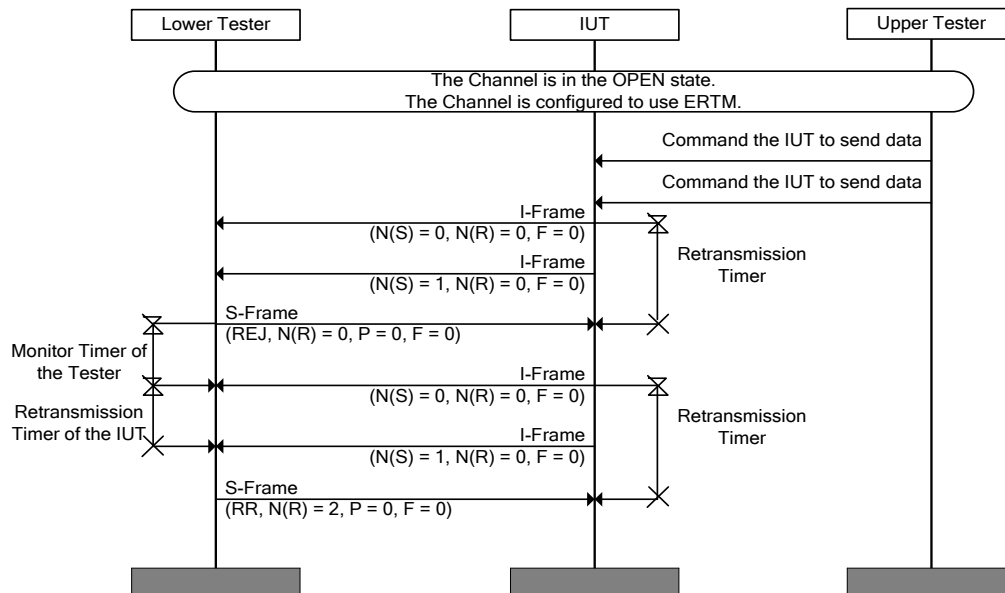

Figure 4.88: L2CAP/ERM/BV-13-C [Respond to S-Frame [REJ]] MSC

- Expected Outcome

Pass verdict

The IUT retransmits the first I-frame requested in the REJ from the Lower Tester before the Monitor Timer of the Lower Tester expires.

The IUT retransmits the second I-frame requested in the REJ from the Lower Tester before the IUT Retransmission Timer expires.

L2CAP/ERM/BV-14-C [Respond to S-Frame [SREJ] POLL Bit Set]

- Test Purpose

Verify that the IUT responds with the correct I-frame when sent an SREJ frame. Verify that the IUT processes the acknowledgment of previously unacknowledged I-frames.

- Reference

[1] 3.3.2, 8.6.1.3, 8.6.4

- Initial Condition

- The channel is in the OPEN state and configured to use ERTM.
- $I(out)$ outgoing I-frames and $I(in)$ incoming I-frames have been sent and received by the IUT over the channel after it was opened and before the test is executed.
- The MaxTransmit for the IUT is set to a value greater than 1.
- The Lower Tester has specified a value for TxWin of 3 in the Configure Request sent to the IUT.

- Test Procedure

Figure 4.89 assumes I(out) and I(in) are 0. The actual values of N(S) and N(R) for both incoming and outgoing traffic must take the number of previously sent and received I-frames into account.

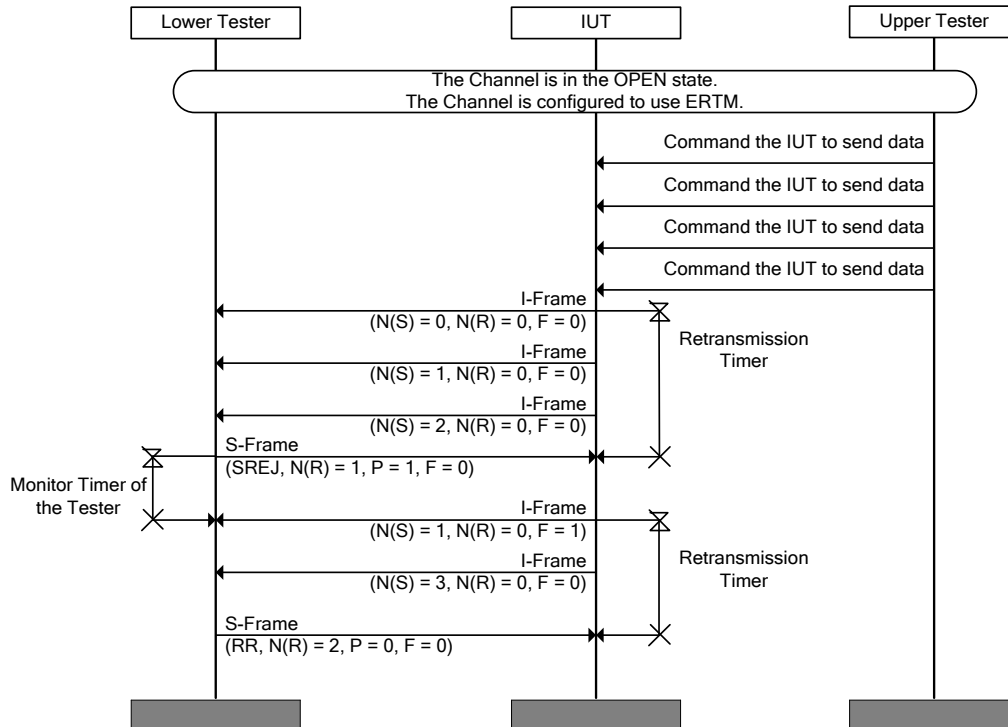

Figure 4.89: L2CAP/ERM/BV-14-C [Respond to S-Frame [SREJ] POLL Bit Set] MSC

- Expected Outcome

Pass verdict

The IUT retransmits the I-frame requested in the SREJ from the Lower Tester before the Monitor Timer of the Lower Tester expires.

The I-frame retransmitted by the IUT has the Final bit = 1.

The IUT processes the acknowledgment of the first I-frame (N(S) = 0) from the SREJ received and consequently send the pending I-frame (N(S) = 3).

L2CAP/ERM/BV-15-C [Respond to S-Frame [SREJ] POLL bit clear]

- Test Purpose

Verify that the IUT responds with the correct I-frame when sent an SREJ frame.

- Reference

[1] 3.3.2, 8.6.1.3, 8.6.4

- Initial Condition

- The channel is in the OPEN state and configured to use ERTM.
- I(out) outgoing I-frames and I(in) incoming I-frames have been sent and received by the IUT over the channel after it was opened and before the test is executed.

- The MaxTransmit for the IUT is set to a value greater than 1.
- The Lower Tester has specified a value for TxWin of 3 in the Configure Request sent to the IUT.
- Test Procedure

Figure 4.90 assumes I(out) and I(in) are 0. The actual values of N(S) and N(R) for both incoming and outgoing traffic must take the number of previously sent and received I-frames into account.

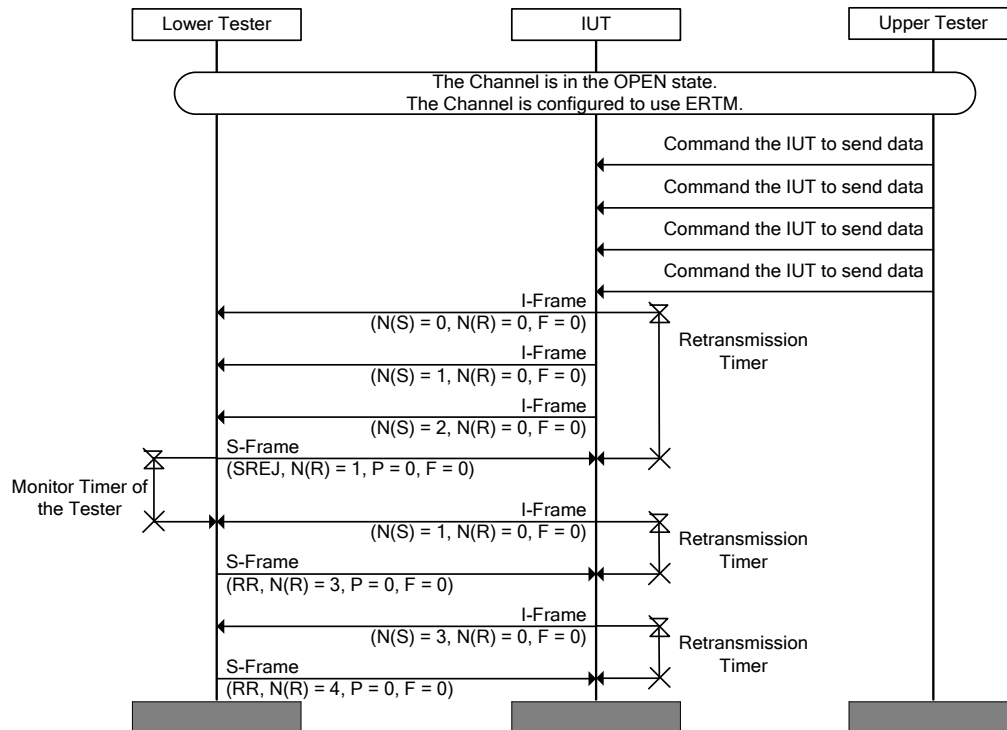

Figure 4.90: L2CAP/ERM/BV-15-C [Respond to S-Frame [SREJ] POLL bit clear] MSC

- Expected Outcome

Pass verdict

The IUT retransmits the I-frame requested in the SREJ from the Lower Tester before the Monitor Timer of the Lower Tester expires.

The IUT does not transmit I-frame (N(S) = 3) as a result of receiving the SREJ from the Lower Tester.

L2CAP/ERM/BV-16-C [Send S-Frame [REJ]]

- Test Purpose

Verify that the IUT can send an S-frame [REJ] after receiving out of sequence I-frames.

- Reference

[1] 3.3.2, 8.6.1.2, 8.6.4

- Initial Condition

- The TxWindow size of the Lower Tester must be greater than 2 and should be the largest value that can be supported by the IUT.
- The channel is in the OPEN state and configured to use ERTM.



- I(out) outgoing I-frames and I(in) incoming I-frames have been sent and received by the IUT over the channel after it was opened and before the test is executed.

- Test Procedure

Figure 4.91 assumes I(out) and I(in) are 0. The actual values of N(S) and N(R) for both incoming and outgoing traffic must take the number of previously sent and received I-frames into account.

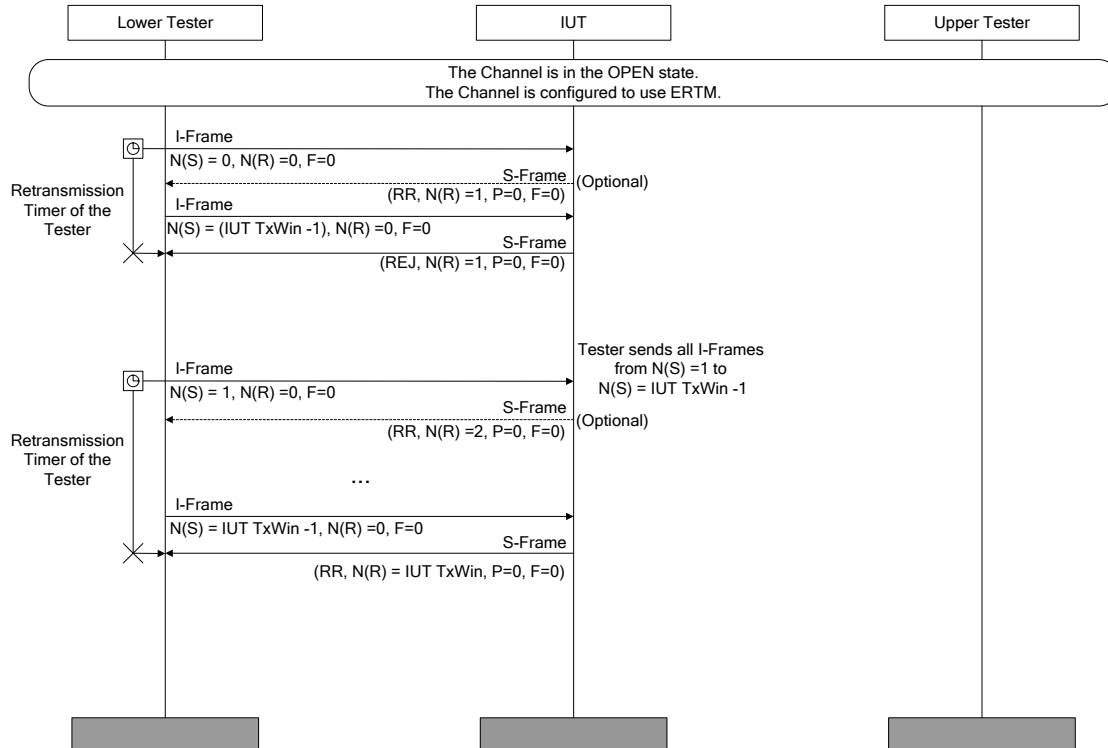

Figure 4.91: L2CAP/ERM/BV-16-C [Send S-Frame [REJ]] MSC

- Expected Outcome

Pass verdict

The IUT sends an S-frame REJ requesting I-frames with N(S) >= 1 prior to the Retransmission timer of the Lower Tester expiring.

The IUT acknowledges all the I-frames that are sent by the Lower Tester after the S-frame REJ is sent.

L2CAP/ERM/BV-17-C [Send S-Frame [SREJ]]

- Test Purpose

Verify that the IUT can send an S-frame [SREJ] after receiving out of sequence I-frames.

- Reference

[1] 3.3.2, 8.6.1.3, 8.6.4

- Initial Condition

- The TxWindow size of the Lower Tester must be greater than 2.
- The channel is in the OPEN state and configured to use ERTM.

- I(out) outgoing I-frames and I(in) incoming I-frames have been sent and received by the IUT over the channel after it was opened and before the test is executed.

- Test Procedure

Figure 4.92 assumes I(out) and I(in) are 0. The actual values of N(S) and N(R) for both incoming and outgoing traffic must take the number of previously sent and received I-frames into account.

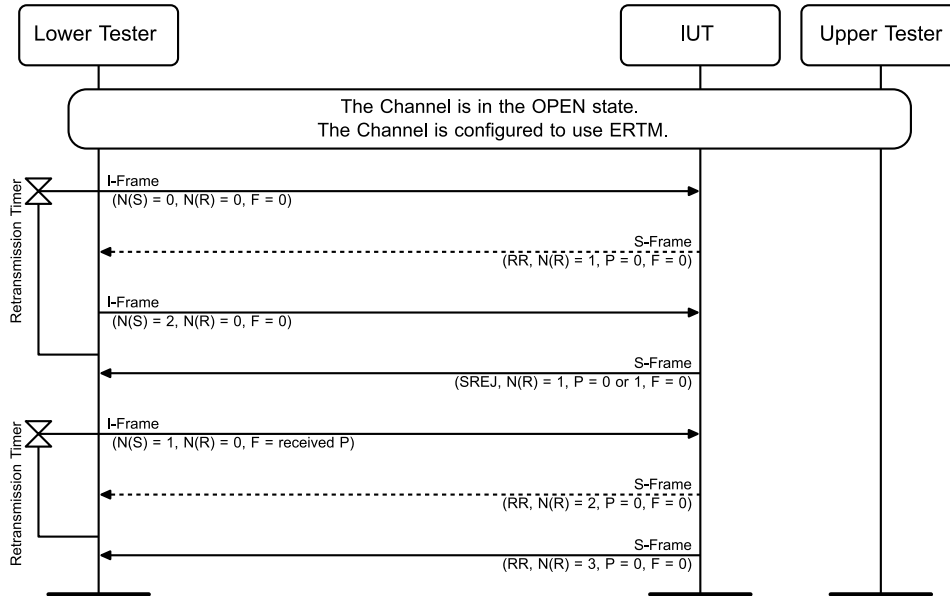

Figure 4.92: L2CAP/ERM/BV-17-C [Send S-Frame [SREJ]] MSC

- Expected Outcome

Pass verdict

The IUT sends an S-frame SREJ requesting I-frame with N(S) = 1 prior to the Retransmission timer of the Lower Tester expiring.

The IUT acknowledges all the I-frames that are sent by the Lower Tester.

L2CAP/ERM/BV-18-C [Receive S-Frame [RR] Final Bit = 1]

- Test Purpose

Verify that the IUT retransmits any previously sent I-frames unacknowledged by receipt of an S-Frame [RR] with the Final Bit set.

- Reference

[1] 3.3.2, 8.6.1.4, 8.6.4

- Initial Condition

- The channel is in the OPEN state and configured to use ERTM.
- I(out) outgoing I-frames and I(in) incoming I-frames have been sent and received by the IUT over the channel after it was opened and before the test is executed.
- MaxTransmit for the IUT is set to a value greater than 1.

- Test Procedure

Figure 4.93 assumes I(out) and I(in) are 0. The actual values of N(S) and N(R) for both incoming and outgoing traffic must take the number of previously sent and received I-frames into account.

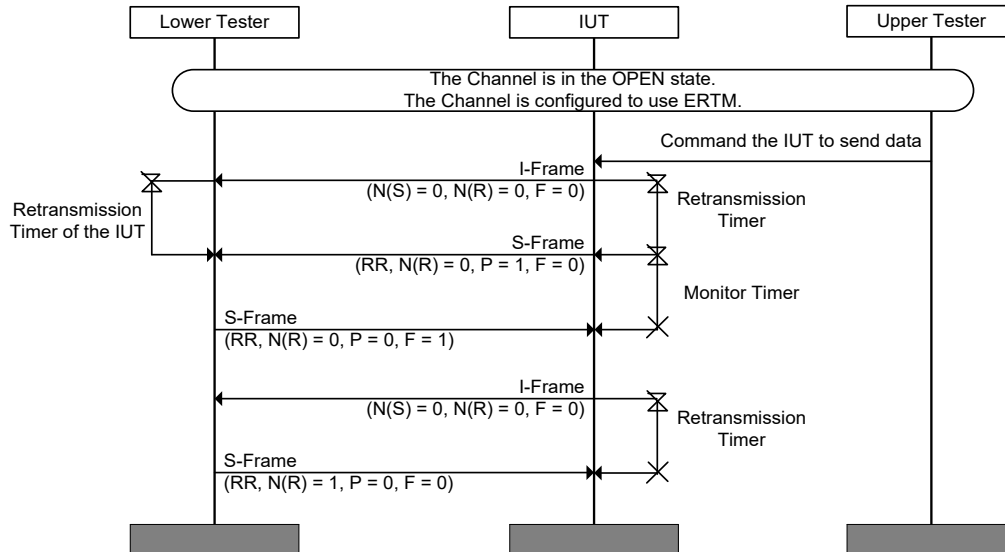

Figure 4.93: L2CAP/ERM/BV-18-C [Receive S-Frame [RR] Final Bit = 1] MSC

- Expected Outcome

Pass verdict

The IUT retransmits the I-frame when it receives the S-frame from the Lower Tester that indicates that the previous transmission failed.

L2CAP/ERM/BV-19-C [Receive I-Frame Final Bit = 1]

- Test Purpose

Verify that the IUT retransmits any previously sent I-frames unacknowledged by receipt of an I-frame with the final bit set.

- Reference

[1] 3.3.2, 8.6.1.4, 8.6.4

- Initial Condition

- The channel is in the OPEN state and configured to use ERTM.
- I(out) outgoing I-frames and I(in) incoming I-frames have been sent and received by the IUT over the channel after it was opened and before the test is executed.
- MaxTransmit for the IUT is set to a value greater than 1.

- Test Procedure

Figure 4.94 assumes I(out) and I(in) are 0. The actual values of N(S) and N(R) for both incoming and outgoing traffic must take the number of previously sent and received I-frames into account.

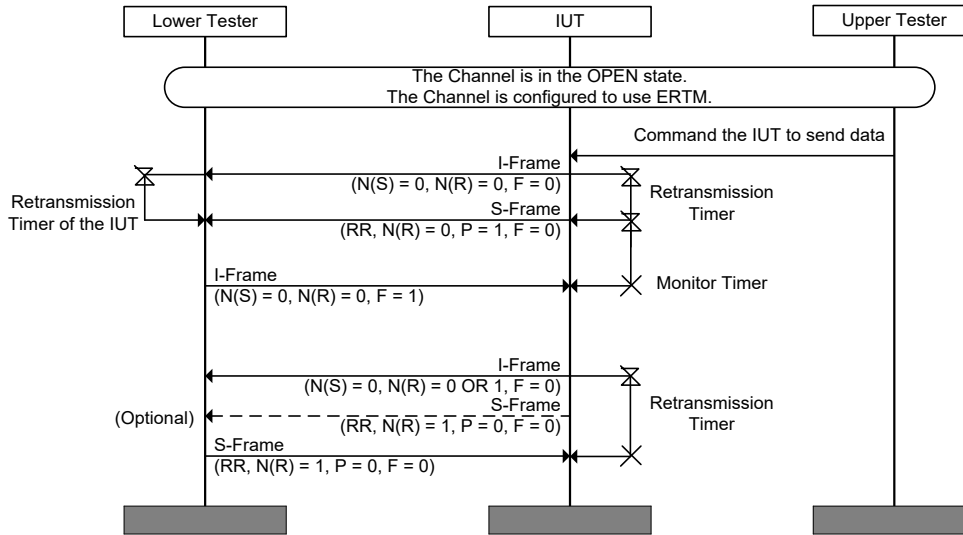

Figure 4.94: L2CAP/ERM/BV-19-C [Receive I-Frame Final Bit = 1] MSC

- Expected Outcome

Pass verdict

The IUT retransmits the I-frame when it receives the I-frame from the Lower Tester that indicates that the previous transmission failed.

L2CAP/ERM/BV-20-C [Enter Remote Busy Condition]

- Test Purpose

Verify that the IUT does not retransmit any I-frames when it receives a remote busy indication from the Lower Tester (S-frame [RNR]).

- Reference

[1] 3.3.2, 8.6.4

- Initial Condition

- The channel is in the OPEN state and configured to use ERTM.
- I(out) outgoing I-frames and I(in) incoming I-frames have been sent and received by the IUT over the channel after it was opened and before the test is executed.
- MaxTransmit for the IUT is set to a value greater than 1.

- Test Procedure

Figure 4.95 assumes I(out) and I(in) are 0. The actual values of N(S) and N(R) for both incoming and outgoing traffic must take the number of previously sent and received I-frames into account.

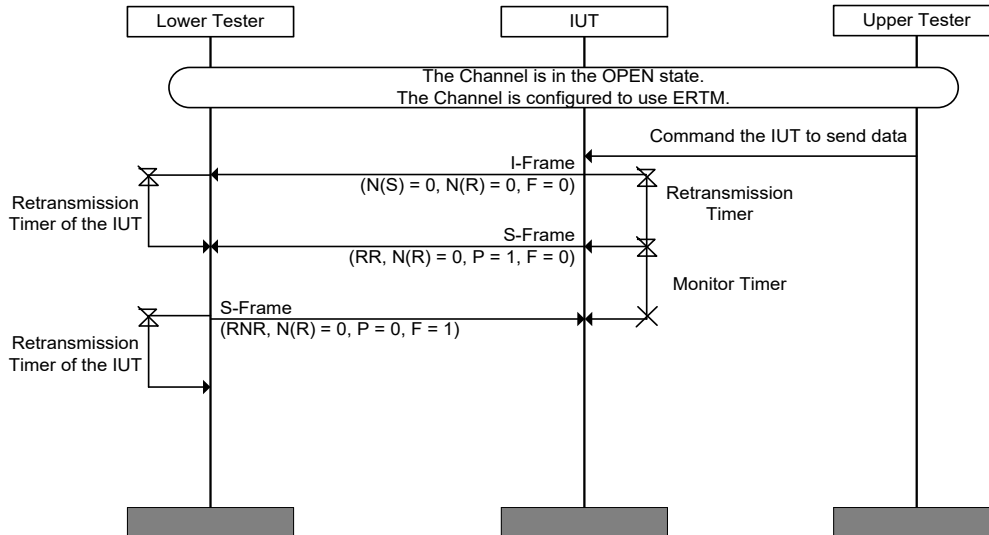

Figure 4.95: L2CAP/ERM/BV-20-C [Enter Remote Busy Condition] MSC

- Expected Outcome

Pass verdict

The IUT does not retransmit the unacknowledged I-frame.

L2CAP/ERM/BV-22-C [Exit Local Busy Condition]

- Test Purpose

Verify that the IUT sends an S-frame [RR] Poll = 1 when the local busy condition is cleared.

- Reference

[1] 3.3.2, 8.6.4

- Initial Condition

- Run test L2CAP/ERM/BV-07-C [Send S-Frame [RNR]].

- Test Procedure

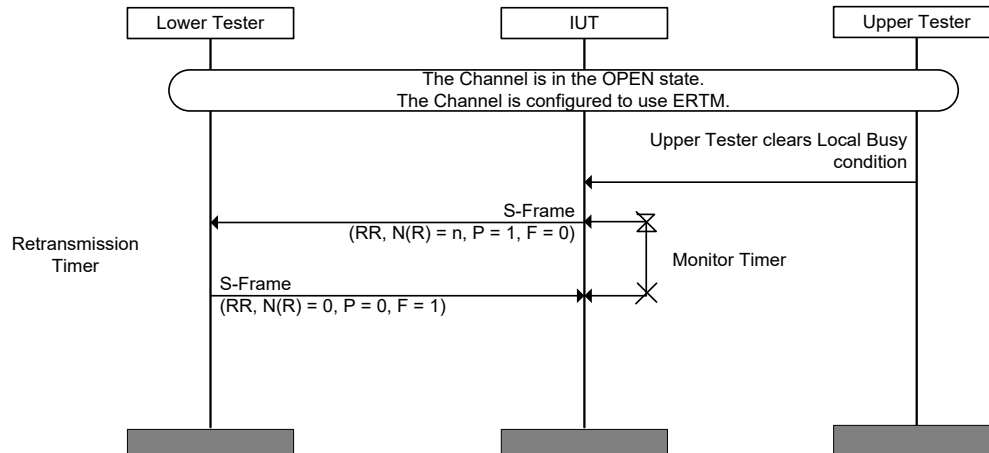

Figure 4.96: L2CAP/ERM/BV-22-C [Exit Local Busy Condition] MSC

- Expected Outcome

Pass verdict

The IUT sends an S-frame RR with the POLL bit set.

L2CAP/ERM/BV-23-C [Transmit I-Frames using SAR]

- Test Purpose

Verify that the IUT can send correctly formatted sequential I-frames with valid values for the enhanced control fields (SAR, F-bit, ReqSeq, TxSeq) when performing SAR.

- Reference

[1] 3.3.2

- Initial Condition

- The connection is configured as ERTM.
- I(out) outgoing I-frames and I(in) incoming I-frames have been sent and received by the IUT over the channel after it was opened and before the test is executed.
- The Lower Tester has configured a value for the MPS that ensures that the IUT performs SAR. The Lower Tester uses "TSPX_iut_sdu_size_in_bytes" as the value SDUs of N bytes that the IUT sends the Lower Tester.
- The Lower Tester has configured a TxWindow size of 1.

- Test Procedure

Figure 4.97 assumes I(out) and I(in) are 0. The actual values of N(S) and N(R) for both incoming and outgoing traffic must take the number of previously sent and received I-frames into account.

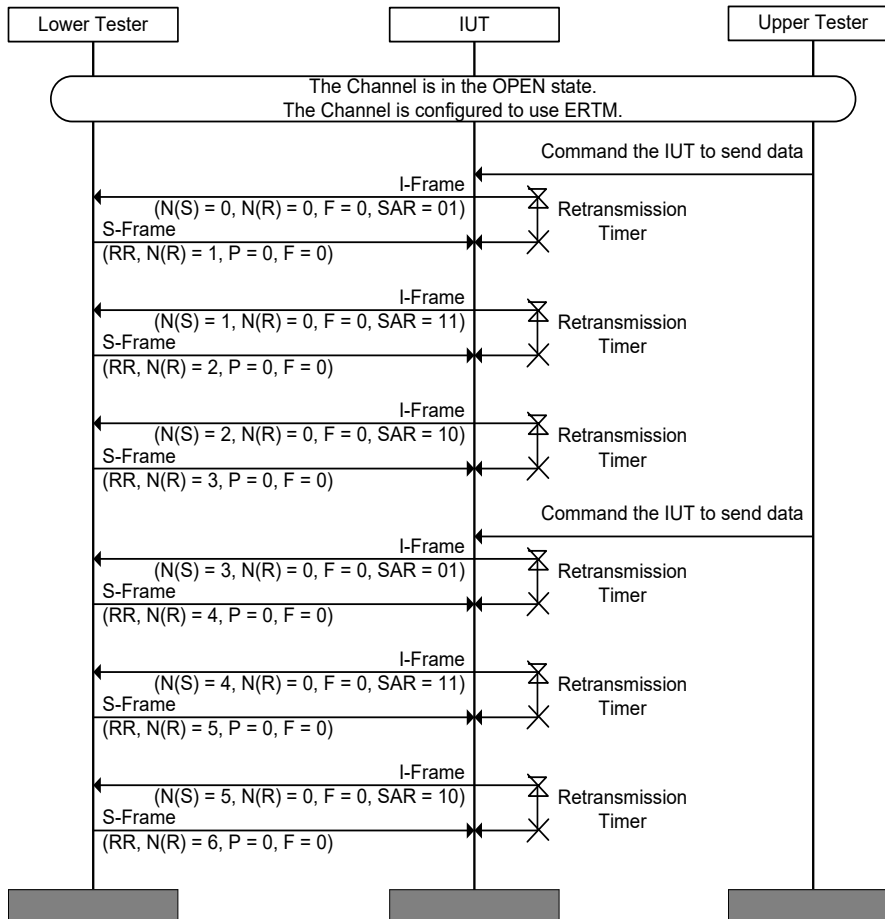

Figure 4.97: L2CAP/ERM/BV-23-C [Transmit I-Frames using SAR] MSC

- Expected Outcome

Pass verdict

The Lower Tester receives six correctly formatted I-frames from the IUT.

L2CAP/ERM/BI-01-C [S-Frame [REJ] Lost or Corrupted]

- Test Purpose

Verify that the IUT can handle receipt of an S-frame [RR] Poll = 1 if the S-frame [REJ] sent from the IUT is lost.

- Reference

[1] 3.3.2, 8.6.1.2, 8.6.4

- Initial Condition

- The TxWindow size of the Lower Tester must be greater than 2 and should be the largest value that can be supported by the IUT.
- The channel is in the OPEN state and configured to use ERTM.

- I(out) outgoing I-frames and I(in) incoming I-frames have been sent and received by the IUT over the channel after it was opened and before the test is executed.

- Test Procedure

Figure 4.98 assumes I(out) and I(in) are 0. The actual values of N(S) and N(R) for both incoming and outgoing traffic must take the number of previously sent and received I-frames into account.

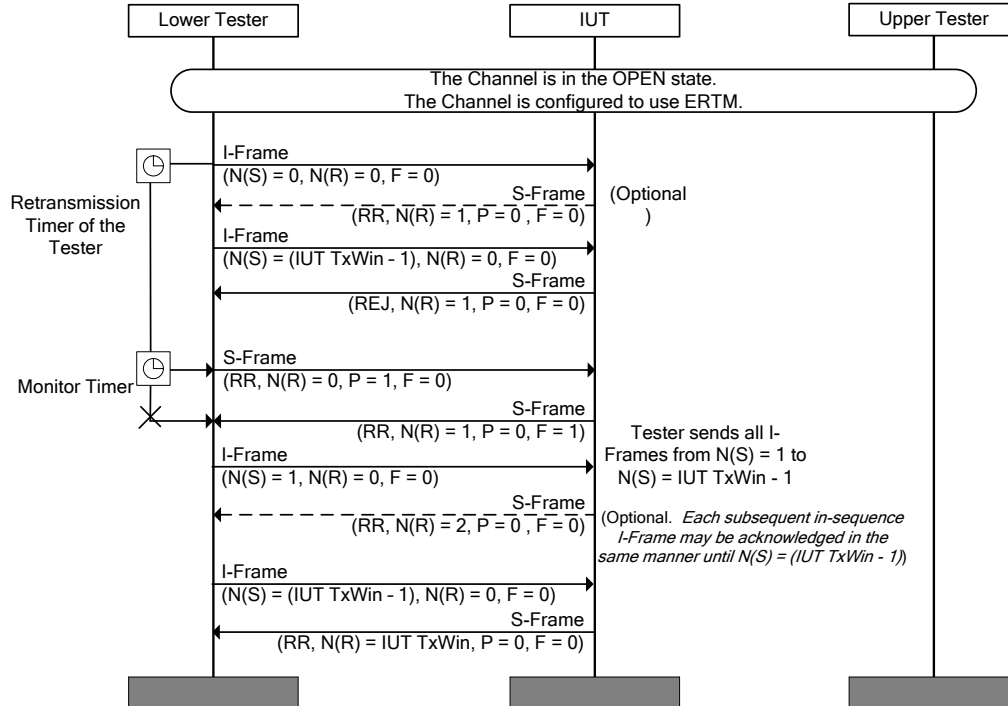

Figure 4.98: L2CAP/ERM/BI-01-C [S-Frame [REJ] Lost or Corrupted] MSC

- Expected Outcome

Pass verdict

The IUT responds to the S-frame [RR] Poll = 1 with an S-frame [RR] Final = 1 that includes the TxSeq of the last received in sequence I-frame.

The IUT acknowledges all the I-frames that are sent by the Lower Tester after the S-frame REJ is sent.

L2CAP/ERM/BI-02-C [S-Frame [SREJ] Lost or Corrupted]

- Test Purpose

Verify that the IUT can handle receipt of an S-frame [RR] Poll = 1 if the S-frame [SREJ] sent from the IUT is lost.

- Reference

[1] 3.3.2, 8.6.1.3, 8.6.4

- Initial Condition

- The TxWindow size of the Lower Tester must be greater than 2.
- The channel is in the OPEN state and configured to use ERTM.

- I(out) outgoing I-frames and I(in) incoming I-frames have been sent and received by the IUT over the channel after it was opened and before the test is executed.

- Test Procedure

Figure 4.99 assumes I(out) and I(in) are 0. The actual values of N(S) and N(R) for both incoming and outgoing traffic must take the number of previously sent and received I-frames into account.

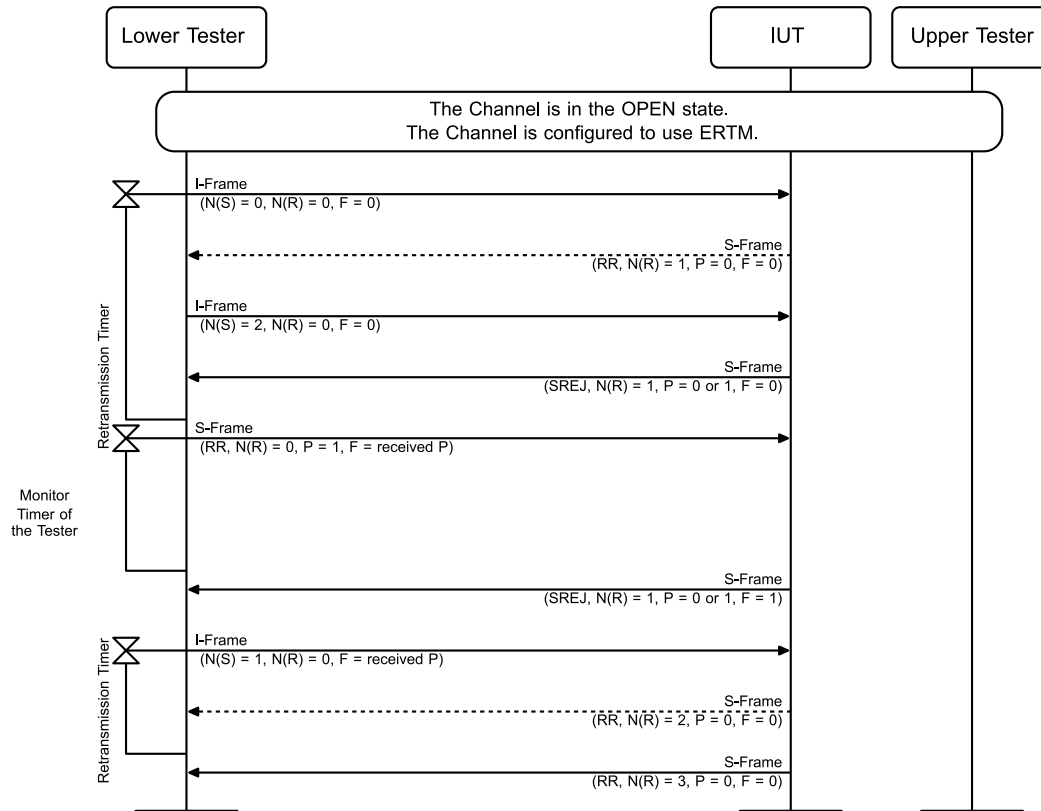

Figure 4.99: L2CAP/ERM/BI-02-C [S-Frame [SREJ] Lost or Corrupted] MSC

- Expected Outcome

Pass verdict

The IUT responds to the S-frame [RR] Poll = 1 with an S-frame [SREJ] Final = 1 that includes the TxSeq of the missing I-frame (N(S) = 1).

The IUT acknowledges all the I-frames that are sent by the Lower Tester after the S-frame SREJ is sent.

L2CAP/ERM/BI-03-C [Handle Duplicate S-Frame [SREJ]]

- Test Purpose

Verify that the IUT only retransmits the requested I-frame once after receiving a duplicate SREJ.

- Reference

[1] 3.3.2, 8.6.1.3, 8.6.4

- Initial Condition
 - The channel is in the OPEN state and configured to use ERTM.
 - I(out) outgoing I-frames and I(in) incoming I-frames have been sent and received by the IUT over the channel after it was opened and before the test is executed.
 - The MaxTransmit for the IUT is set to a value greater than 1.
 - The Lower Tester has specified a value for TxWin > 1 in the Configure Request sent to the IUT.
- Test Procedure

Figure 4.100 assumes I(out) and I(in) are 0. The actual values of N(S) and N(R) for both incoming and outgoing traffic must take the number of previously sent and received I-frames into account.

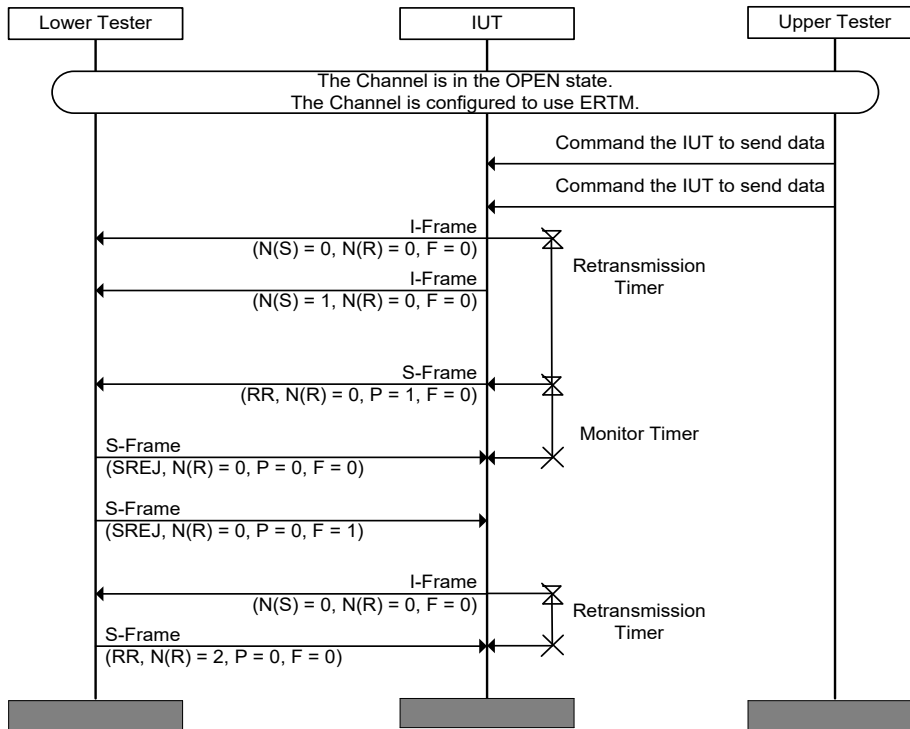

Figure 4.100: L2CAP/ERM/BI-03-C [Handle Duplicate S-Frame [SREJ]] MSC

- Expected Outcome

Pass verdict

The IUT retransmits the I-frame requested in the SREJ from the Lower Tester only once.

L2CAP/ERM/BI-04-C [Handle Receipt of S-Frame [REJ] and S-Frame [RR, F=1] that Both Require Retransmission of the Same I-Frames]

- Test Purpose

Verify that the IUT only retransmits the requested I-frames once after receiving an S-frame [REJ] followed by an S-frame [RR] with the Final bit set that indicates the same I-frames should be retransmitted.

- Reference

[1] 3.3.2, 8.6.1.3, 8.6.4

- Initial Condition
 - The channel is in the OPEN state and configured to use ERTM.
 - I(out) outgoing I-frames and I(in) incoming I-frames have been sent and received by the IUT over the channel after it was opened and before the test is executed.
 - The MaxTransmit for the IUT is set to a value greater than 1.
 - The Lower Tester has specified a value for TxWin > 1 in the Configure Request sent to the IUT.

Test Procedure

Figure 4.101 assumes I(out) and I(in) are 0. The actual values of N(S) and N(R) for both incoming and outgoing traffic must take the number of previously sent and received I-frames into account.

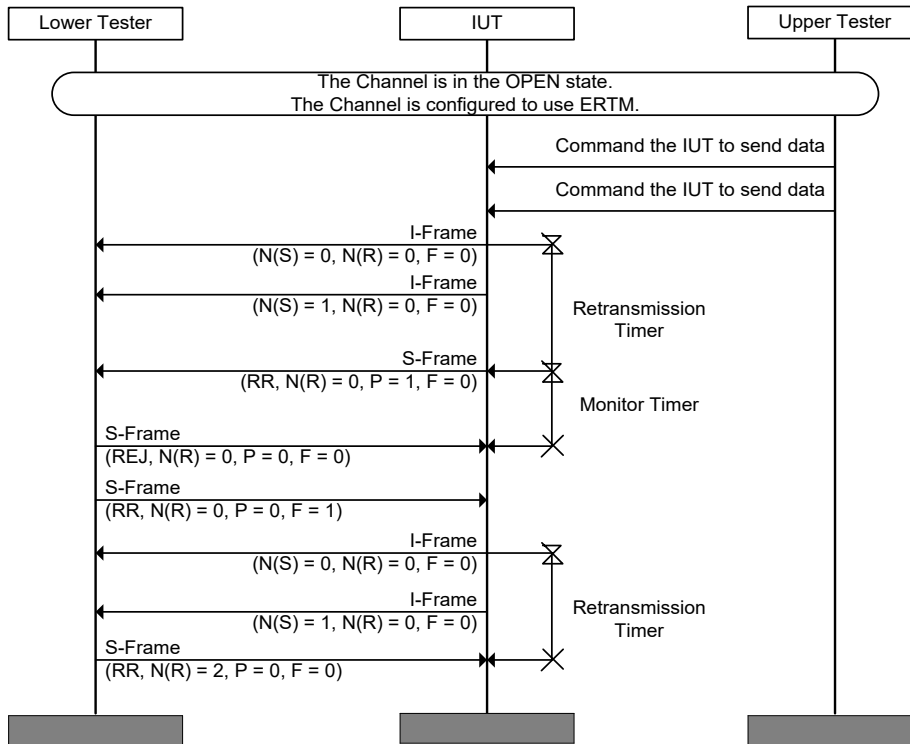

Figure 4.101: L2CAP/ERM/BI-04-C [Handle Receipt of S-Frame [REJ] and S-Frame [RR, F=1] that Both Require Retransmission of the Same I-Frames] MSC

Expected Outcome

Pass verdict

The IUT retransmits the I-frames requested in the REJ from the Lower Tester only once.

L2CAP/ERM/BI-05-C [Handle receipt of S-Frame [REJ] and I-Frame [F=1] that Both Require Retransmission of the Same I-Frames]

Test Purpose

Verify that the IUT only retransmits the requested I-frames once after receiving an S-frame [REJ] followed by an I-frame with the Final bit set that indicates the same I-frames should be retransmitted.

Reference

[1] 3.3.2, 8.6.1.3, 8.6.4

- Initial Condition
 - The channel is in the OPEN state and configured to use ERTM.
 - I(out) outgoing I-frames and I(in) incoming I-frames have been sent and received by the IUT over the channel after it was opened and before the test is executed.
 - The MaxTransmit for the IUT is set to a value greater than 1.
 - The Lower Tester has specified a value for TxWin > 1 in the Configure Request sent to the IUT.

Test Procedure

Figure 4.102 assumes I(out) and I(in) are 0. The actual values of N(S) and N(R) for both incoming and outgoing traffic must take the number of previously sent and received I-frames into account.

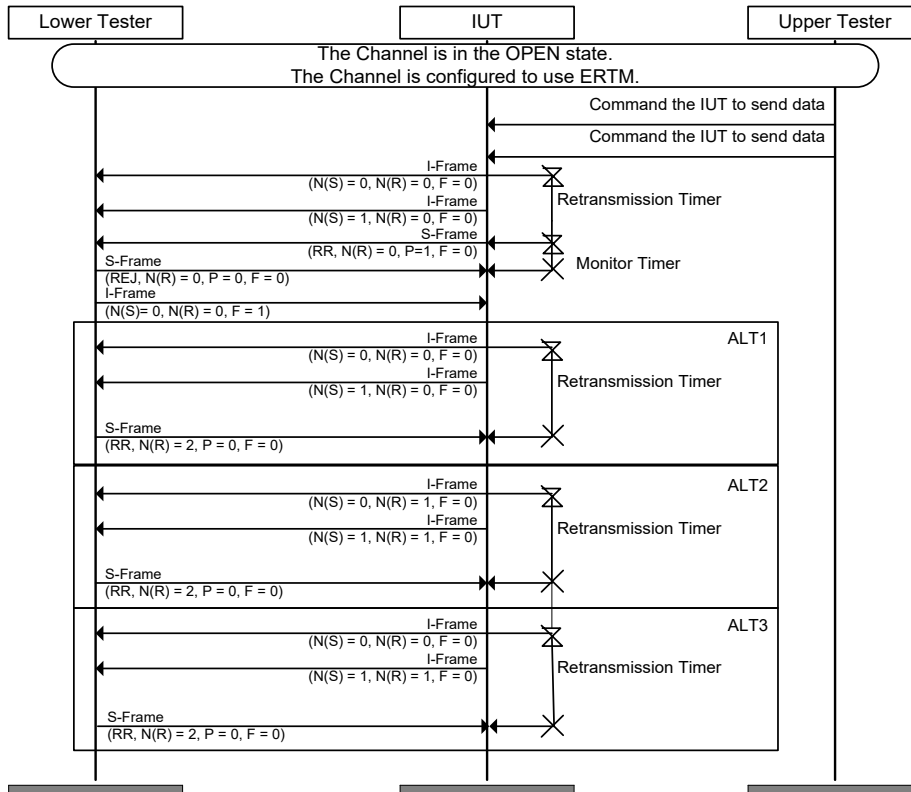

Figure 4.102: L2CAP/ERM/BI-05-C [Handle receipt of S-Frame [REJ] and I-Frame [F=1] that Both Require Retransmission of the Same I-Frames] MSC

Expected Outcome

Pass verdict

The IUT retransmits the I-frames requested in the REJ from the Lower Tester only once.

4.5.8 Streaming Mode (STM)

Verify the correct implementation of Streaming Mode in the IUT.

L2CAP/STM/BV-01-C [Streaming Mode Source]

Test Purpose

Verify that the IUT can send correctly formatted sequential I-frames with valid values for the Control fields (SAR, F-bit, ReqSeq, and TxSeq).



- Reference
 - [1] 3.3.2, 8.7
- Initial Condition
 - The channel is in the OPEN state and configured to use Streaming Mode.
 - No I-frames have been sent from the IUT or the Lower Tester.
- Test Procedure

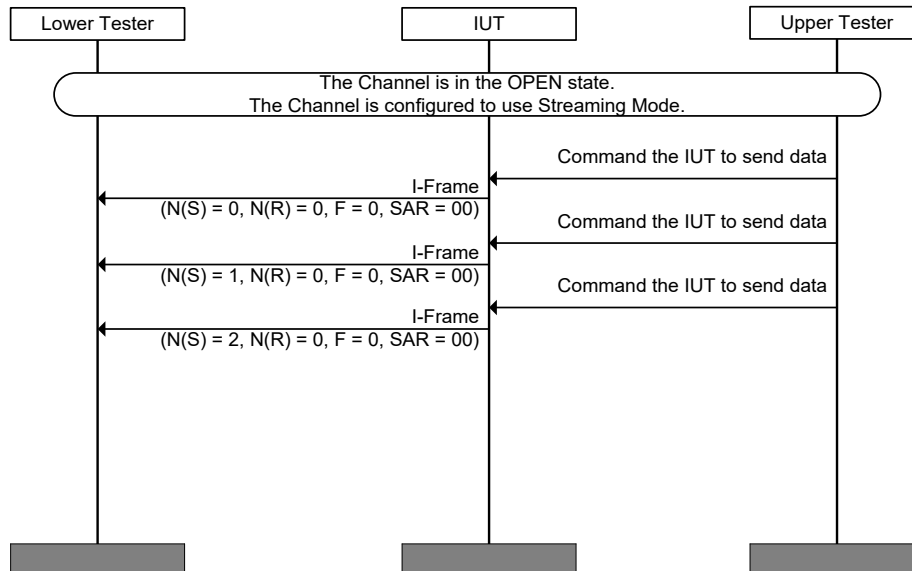

Figure 4.103: L2CAP/STM/BV-01-C [Streaming Mode Source] MSC

- Expected Outcome
 - Pass verdict
 - The Lower Tester receives three correctly formatted I-frames from the IUT.

L2CAP/STM/BV-02-C [Streaming Mode Sink]

- Test Purpose
 - Verify that the IUT receives I-frames and handles SAR correctly.
- Reference
 - [1] 3.3.2, 8.7
- Initial Condition
 - The channel is in the OPEN state and configured to use Streaming Mode.
 - No I-frames have been sent from the IUT or the Lower Tester.
 - The IUT has configured a MTU and MPS size that is greater or equal to 48 bytes.

- Test Procedure

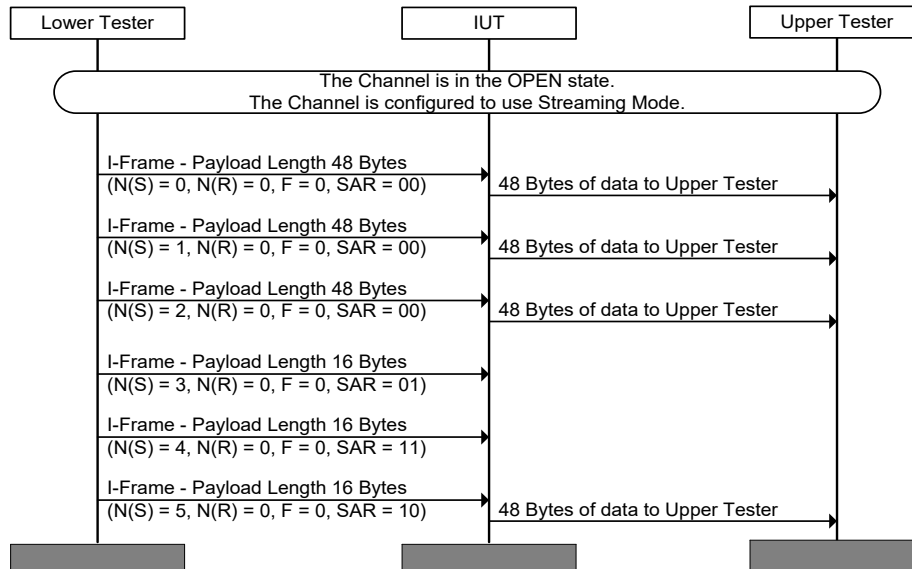

Figure 4.104: L2CAP/STM/BV-02-C [Streaming Mode Sink] MSC

- Expected Outcome

Pass verdict

The IUT passes the received data correctly to the Upper Tester.

L2CAP/STM/BV-03-C [Streaming Mode Source using SAR]

- Test Purpose

Verify that the IUT can send correctly formatted sequential I-frames with valid values for the Control fields (SAR, F-bit, ReqSeq, TxSeq) while performing SAR.

- Reference

[1] 3.3.2, 8.7

- Initial Condition

- The channel is in the OPEN state and configured to use Streaming Mode.
- No I-frames have been sent from the IUT or Lower Tester.
- The Lower Tester has configured a value for the MPS that ensures that the IUT performs SAR. The Lower Tester uses "TSPX_iut_sdu_size_in_bytes" as the value SDUs of N bytes that the IUT sends the Lower Tester.

- Test Procedure

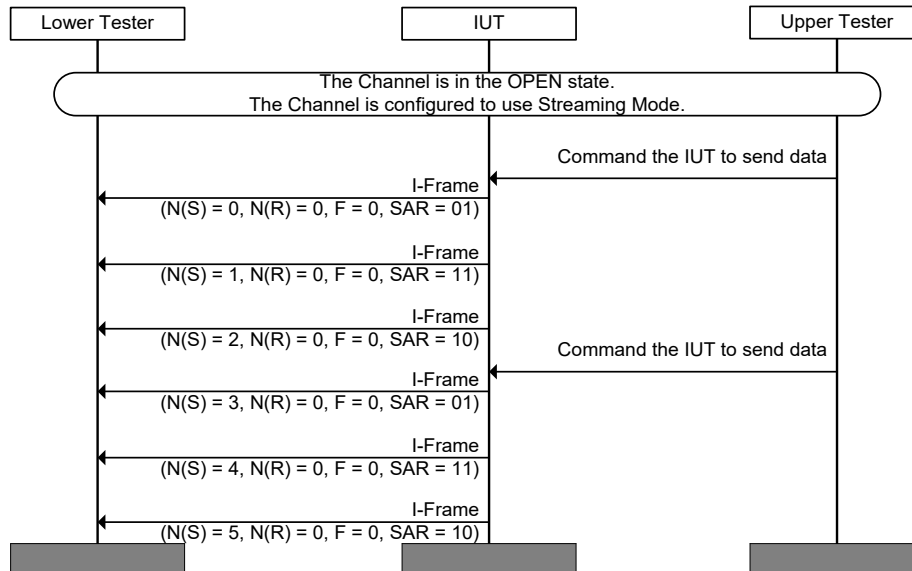

Figure 4.105: L2CAP/STM/BV-03-C [Streaming Mode Source using SAR] MSC

- Expected Outcome

Pass verdict

The Lower Tester receives six correctly formatted I-frames from the IUT.

4.5.9 Fixed Channel Support (FIX)

Verify the correct implementation of fixed channels information response in L2CAP.

L2CAP/FIX/BV-01-C [Fixed Channels Supported Information Request]

- Test Purpose

Verify that the IUT can send an Information Request for the information type of Fixed Channels Supported.

- Reference

[1] 4.10, 4.11, 4.12, 4.13

- Initial Condition

- The IUT has established that the Lower Tester supports Fixed Channels with an Info Request with Info Type set to Extended Features.

- Test Procedure

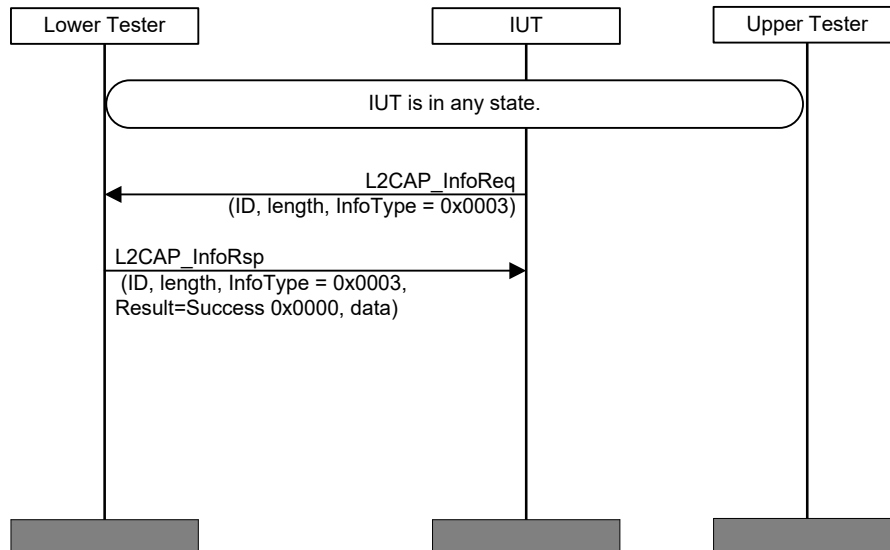

Figure 4.106: L2CAP/FIX/BV-01-C [Fixed Channels Supported Information Request] MSC

- Expected Outcome

Pass verdict

The IUT sends Information Request [InfoType = Fixed Channels].

L2CAP/FIX/BV-02-C [AMP Manager Channel Supported]

- Test Purpose

Verify that the IUT can send an Information Response for the information type of Fixed Channels Supported that contains the map of supported fixed channels with the AMP Manager Protocol Channel (bit-3 of octet 0) set to 1.

- Reference

[1] 4.10, 4.11, 4.12, 4.13

- Initial Condition

- The Lower Tester has established that the IUT supports Fixed Channels by using an Info Request with the Info Type set to 0x0002 (Extended Features).

- Test Procedure

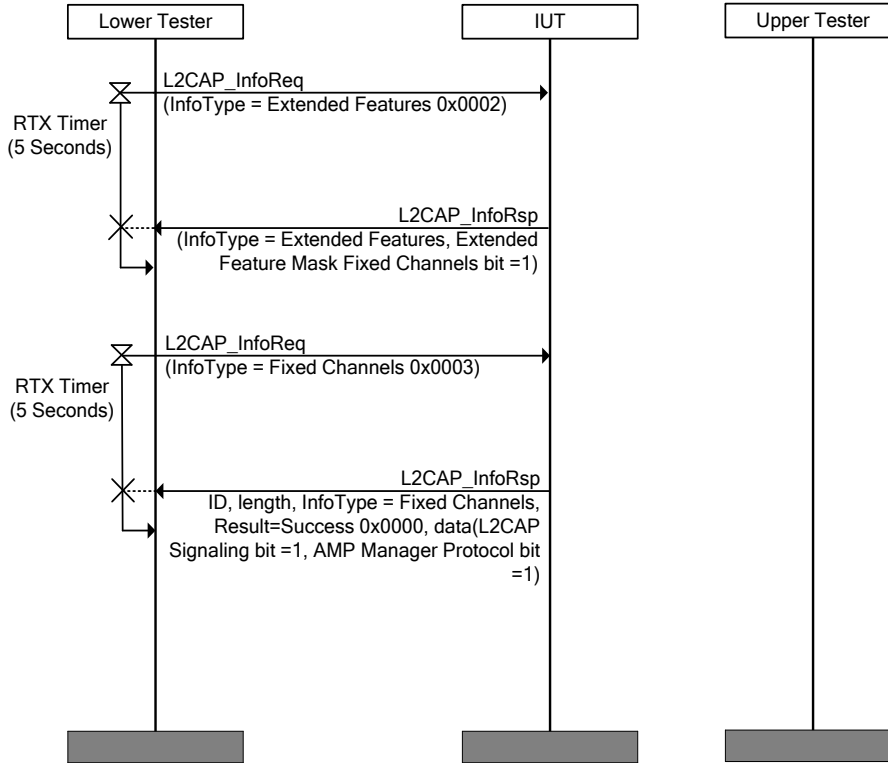

Figure 4.107: L2CAP/FIX/BV-02-C [AMP Manager Channel Supported] MSC

- Expected Outcome

Pass verdict

The IUT sends Information Response [InfoType = Fixed Channels] and a result code of “Success.”

The Fixed Channel Mask bit for L2CAP Signaling channel is set to 1.

The Fixed Channel Mask bit for AMP Manager Protocol channel is set to 1.

L2CAP/FIX/BV-03-C [Information Request, Fixed Channels Supported]

- Test Purpose

Verify that the IUT returns the Fixed Channels Supported in response to the Information Request from the Lower Tester.

- Reference

[11] 4.10

- Initial Condition

- The IUT is in the CLOSED state.
- No ACL link exists between the Lower Tester and the IUT.
- The IUT acts as an L2CAP acceptor.

- Test Procedure

The Lower Tester sends an information request to IUT.

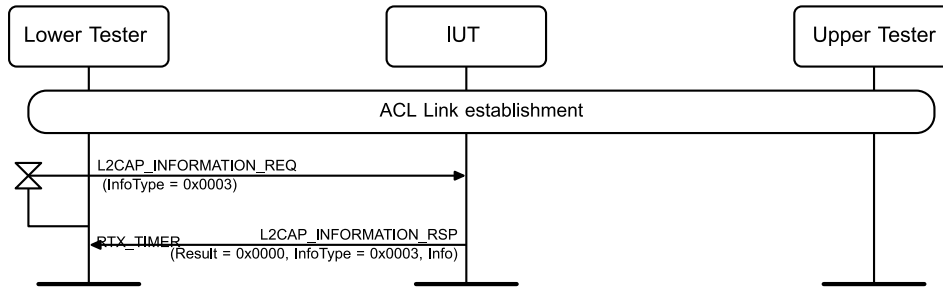

Figure 4.108: L2CAP/FIX/BV-03-C [Information Request, Fixed Channels Supported] MSC

- Expected Outcome

Pass verdict

The IUT sends a correct L2CAP_INFORMATION_RSP PDU to the Lower Tester with the Info parameter containing 8 octets with the IUT Fixed L2CAP Channels. In the Info parameter, the octets match Table 4.25. In Table 4.25, the bit is set if the ICS entry is selected. All bits not listed are set to 0b0.

CID	Octet	Bit	Value
0x0000 (Null ID)	0	0	0b0
0x0001 (L2CAP Signaling Channel)	0	1	0b1
0x0002 (Connectionless reception)	0	2	L2CAP 2/35
0x0003 (AMP Manager)	0	3	L2CAP 2/31
0x0007 (BR/EDR Security Manager)	0	7	0b0 OR 0b1
0x003F (AMP Test Manager)	7	7	L2CAP 2/29

Table 4.25: Fixed Channels Supported Mask bits

- Notes

The Lower Tester's RTX timer is set to maximum allowed initial value.

All CIDs that are RFU are set to 0b0.

4.5.10 Extended Window Size Configuration (EWC)

Verify the configuration of the Extended Window size option of L2CAP.

L2CAP/EWC/BV-01-C [IUT Initiated Extended Window Size Option]

- Test Purpose

Verify that the IUT can configure a channel to use the Extended Window size option.

- Reference

[1] 4.4, 4.5, 5.5, 6.1.4, 7.1

- Initial Condition

- The IUT has established that the peer L2CAP entity supports configuration of the Extended Window Size option (using the Information Request/Response [Extended Features] mechanism).

- Test Procedure

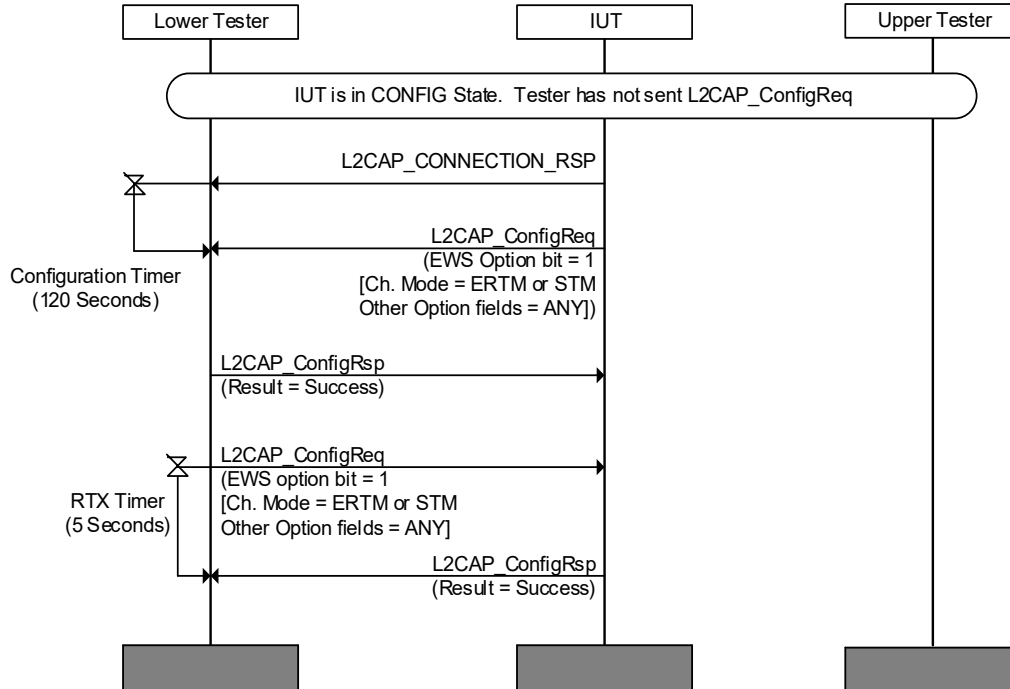

Figure 4.109: L2CAP/EWC/BV-01-C [IUT Initiated Extended Window Size Option] MSC

- Expected Outcome

Pass verdict

The channel is established.

The IUT sends an L2CAP_CONFIGURATION_REQ including the Extended Feature Mask bit for Extended Window size option before the Configuration timer expires.

The IUT responds with Success to the Lower Tester sending an L2CAP_CONFIGURATION_REQ including the Extended Window size option.

L2CAP/EWC/BV-02-C [Lower Tester Requests Extended Window Size]

- Test Purpose

Verify that the IUT uses the Extended Control Field in I/S-frames if the Lower Tester requests that Extended Window Size is used.

- Reference

[1] 3.3.2, 4.4, 4.5, 5.7, 6.1.4, 7.1, 8.2 (CSA1)

- Initial Condition

- L2CAP/EWC/BV-01-C [IUT Initiated Extended Window Size Option] test case was completed successfully.

- Test Procedure

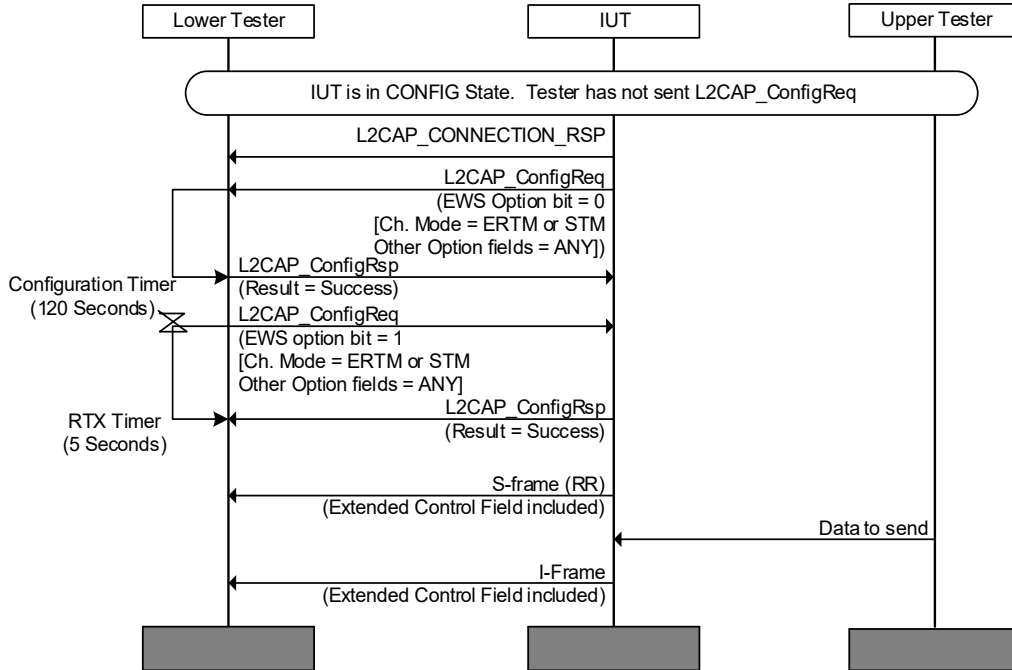

Figure 4.110: L2CAP/EWC/BV-02-C [Lower Tester Requests Extended Window Size] MSC

- Expected Outcome

Pass verdict

The channel is established.

The IUT accepts the EWS option while configuring.

The IUT includes ECF in S-frames sent to the Lower Tester.

The IUT includes ECF in I-frames sent to the Lower Tester.

L2CAP/EWC/BV-03-C [Extended Window Size Option Not Supported by Lower Tester]

- Test Purpose

Verify that the IUT does not include an Extended Window Size option when configuring the channel if the Lower Tester does not indicate support for the Extended Windows Size option in the Information Response [Extended Features].

- Reference

[1] 4.4, 4.5, 5.5, 6.1.4, 7.1.3

- Initial Condition

- An ACL connection has been established by the Lower Tester.

- Test Procedure

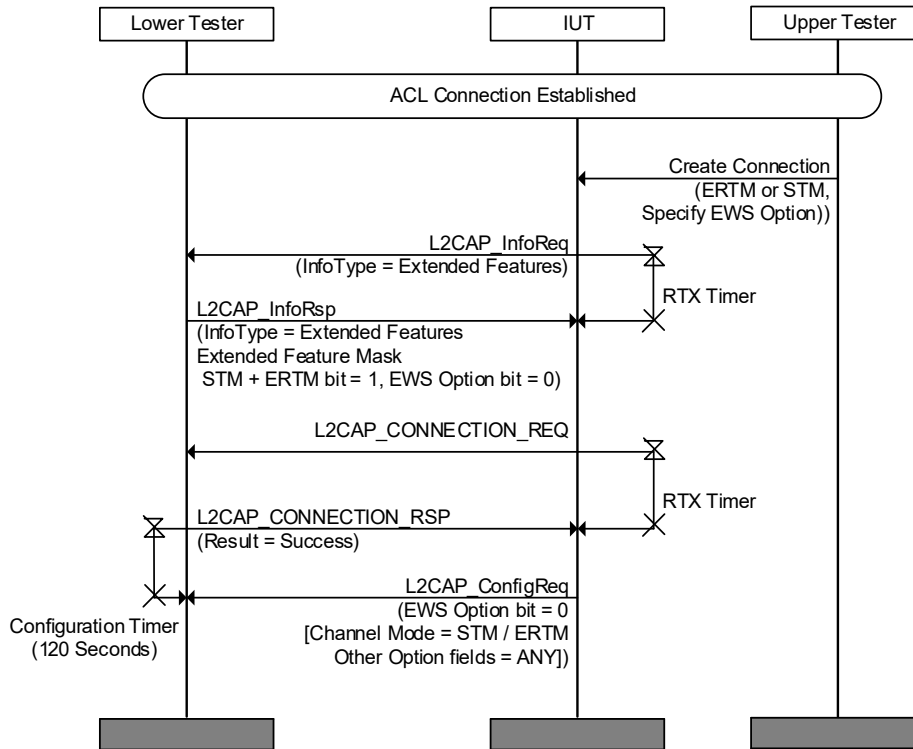

Figure 4.111: L2CAP/EWC/BV-03-C [Extended Window Size Option Not Supported by Lower Tester] MSC

- Expected Outcome

Pass verdict

The IUT sends L2CAP_CONFIGURATION_REQ before Configuration Timer expires, with EWS option bit = 0.

4.5.11 Lock Step Configuration (LSC)

Verify the correct implementation of the Lock Step configuration Process.

L2CAP/LSC/BV-01-C [Normal Lock Step Configuration Process for Best Effort, BR/EDR ERTM Channel]

- Test Purpose

Verify that the IUT performs the Lock-step Configuration process including sending a properly formatted Enhanced Flow Specification option for service type “Best Effort”.

- Reference

[8] 7.1.3

- Initial Condition

- An ACL connection has been established by the Lower Tester.
- The IUT has established that the peer L2CAP entity supports Lockstep Configuration Process using the Information Request/Response [Extended Features] mechanism.

- L2CAP channel is established over BR/EDR using ERTM with the Extended Flow Specification bit set in the IUT's Extended Features Mask.
- The IUT is in CONFIG state.
- Test Procedure

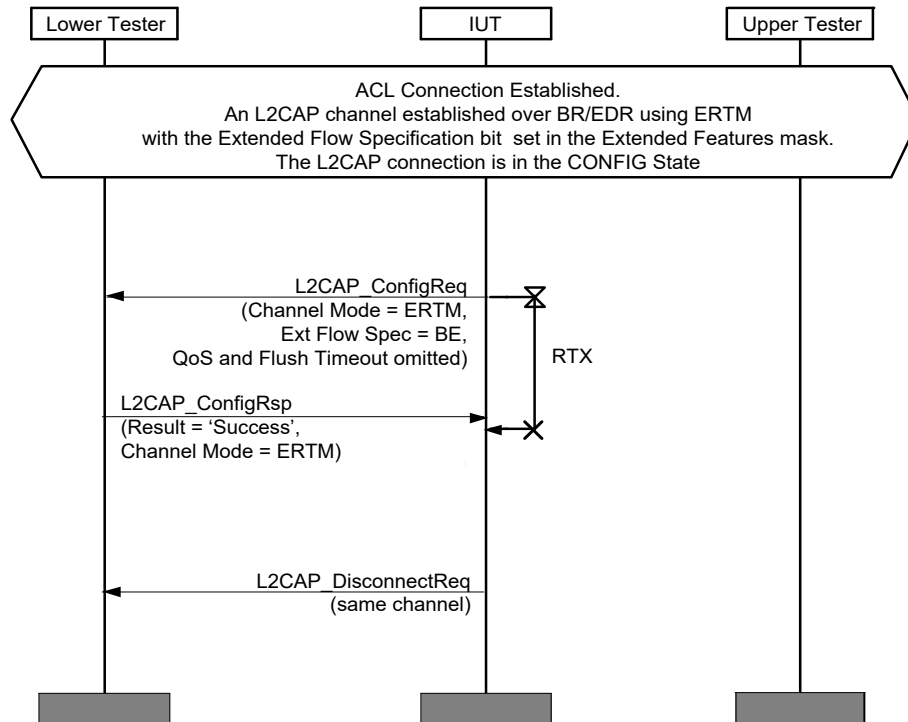

Figure 4.112: L2CAP/LSC/BV-01-C [Normal Lock Step Configuration Process for Best Effort, BR/EDR ERTM Channel] MSC

- Expected Outcome

Pass verdict

The IUT sends an L2CAP_CONFIGURATION_REQ packet with Extended Flow Spec options for BE.

The IUT responds to an L2CAP_CONFIGURATION_REQ packet, including Extended Flow Spec options for BE, with status pending before its RTx timer expires.

The IUT sends an L2CAP_CONFIGURATION_RSP packet with status success after reception of L2CAP_CONFIGURATION_RSP with status.

L2CAP/LSC/BV-02-C [Normal Lock Step Configuration Process for Guaranteed, BR/EDR ERTM Channel]

- Test Purpose

Verify that the IUT performs the Lock-step Configuration process including sending a properly formatted Enhanced Flow Specification option for service type "Guaranteed".

- Reference

[8] 7.1.3

- Initial Condition
 - An ACL connection has been established by the Lower Tester.
 - The IUT has established that the peer L2CAP entity supports Lockstep Configuration Process using the Information Request/Response [Extended Features] mechanism.
 - L2CAP channel is established over BR/EDR using ERTM with the Extended Flow Specification bit set in the IUT's Extended Features Mask.
 - The IUT is in CONFIG state.
- Test Procedure

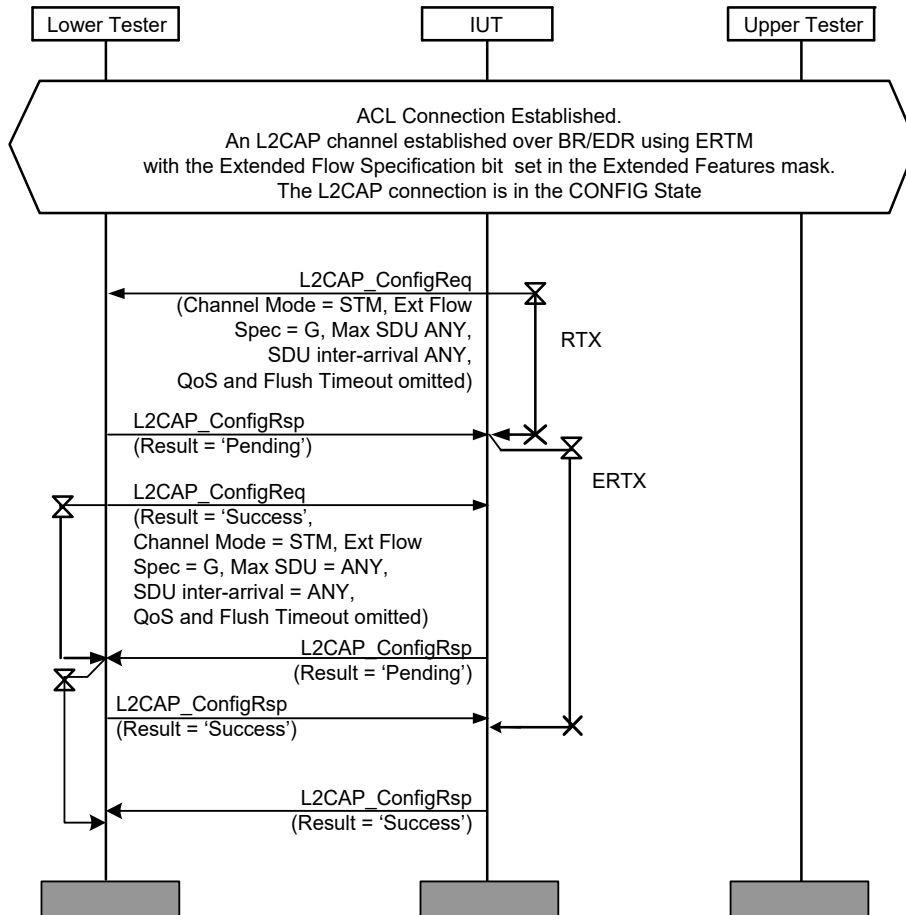

Figure 4.113: L2CAP/LSC/BV-02-C [Normal Lock Step Configuration Process for Guaranteed, BR/EDR ERTM Channel] MSC

- Expected Outcome

Pass verdict

The channel is established.

The IUT sends an L2CAP_CONFIGURATION_REQ packet with Extended Flow Spec options for Guaranteed.

The IUT responds to an L2CAP_CONFIGURATION_REQ packet with Extended Flow Spec options for Guaranteed, with status “pending” before its RTX timer expires.

The IUT sends an L2CAP_CONFIGURATION_RSP packet with status “success” after reception of L2CAP_CONFIGURATION_REQ with status pending before its ERTX timer expires.

L2CAP/LSC/BV-03-C [Premature Success in Configuration Response, BR/EDR ERTM Channel]

• Test Purpose

Verify that the IUT closes the channel if it receives a Configuration response packet with result “success” before receiving a Configuration response packet with result “pending”.

• Reference

[8] 7.1.3

• Initial Condition

- An ACL connection has been established by the Lower Tester.
- L2CAP channel is established over BR/EDR using ERTM with the Extended Flow Specification bit set in the IUT’s Extended Features Mask.
- The IUT is in CONFIG state.

• Test Procedure

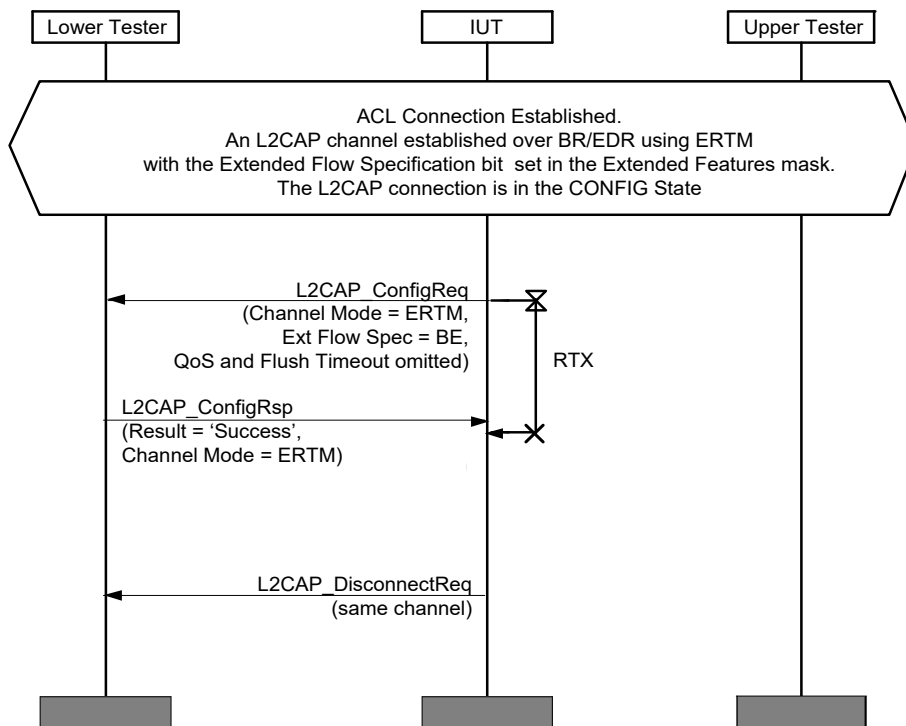

Figure 4.114: L2CAP/LSC/BV-03-C [Premature Success in Configuration Response, BR/EDR ERTM Channel] MSC

• Expected Outcome

Pass verdict

The IUT stays in CONFIG state after receiving L2CAP_CONFIGURATION_RSP with results before receiving L2CAP_CONFIGURATION_RSP with “pending” status.

The IUT sends L2CAP_DISCONNECTION_REQ with the same channel specified.



L2CAP/LSC/BI-04-C [Mismatched Service Type, Best Effort, BR/EDR ERTM Channel]

• Test Purpose

Verify that the IUT closes the channel if it sends a Configuration request containing an Extended Flow Specification with service type “Best Effort” and receives a Configuration request packet with an Extended Flow Specification containing service type “Guaranteed”. See test case [L2CAP/LSC/BV-03-C \[Premature Success in Configuration Response, BR/EDR ERTM Channel\]](#).

• Reference

[8] 7.1.3

• Initial Condition

- An ACL connection has been established by the Lower Tester.
- L2CAP channel is established over BR/EDR using ERTM with the Extended Flow Specification bit set in the IUT’s Extended Features Mask.
- The IUT is in CONFIG state.

• Test Procedure

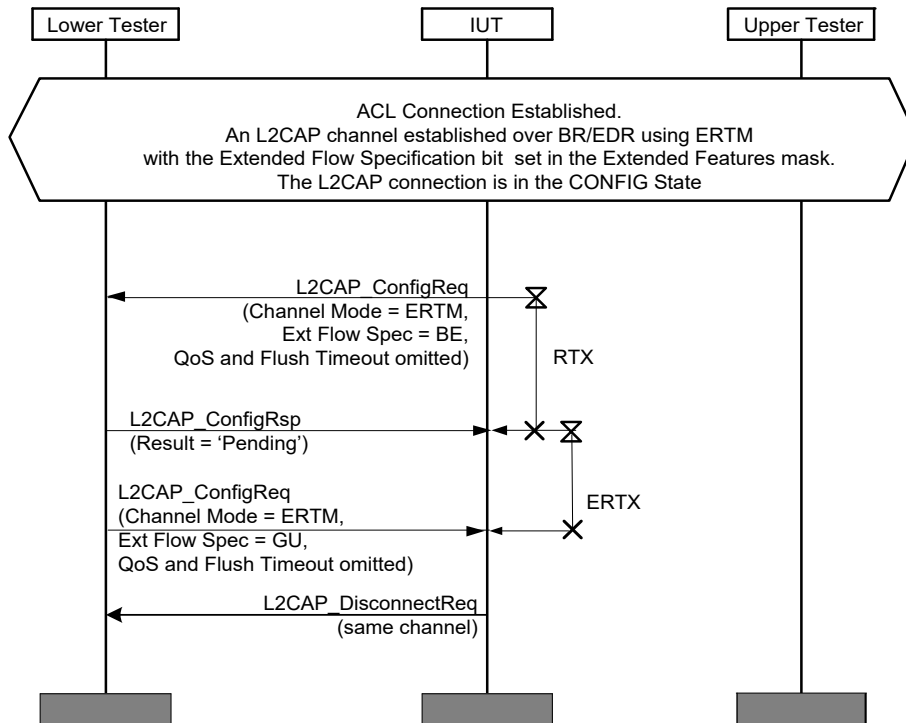

Figure 4.115: L2CAP/LSC/BI-04-C [Mismatched Service Type, Best Effort, BR/EDR ERTM Channel] MSC

• Expected Outcome

Pass verdict

The IUT rejects mismatched L2CAP_CONFIGURATION_RSP by sending an L2CAP_DISCONNECTION_REQ.

L2CAP/LSC/BI-05-C [Mismatched Service Type, Guaranteed, BR/EDR ERTM Channel]

• Test Purpose

Verify that the IUT closes the channel if it sends a Configuration request containing an Extended Flow Specification with service type “Guaranteed” and receives a Configuration response packet with an Extended Flow Specification containing service type “Best Effort”.

See test case [L2CAP/LSC/BV-03-C \[Premature Success in Configuration Response, BR/EDR ERTM Channel\]](#).

• Reference

[8] 7.1.3

• Initial Condition

- An ACL connection has been established by the Lower Tester.
- L2CAP channel is established over BR/EDR using ERTM with the Extended Flow Specification bit set in the IUT’s Extended Features Mask.
- The IUT is in CONFIG state.

• Test Procedure

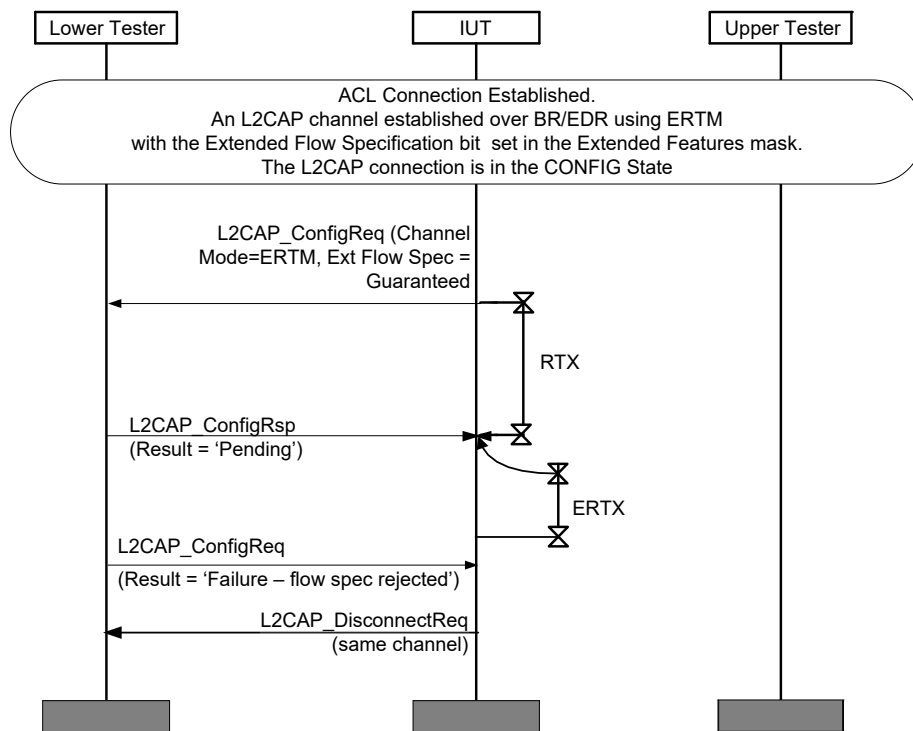

Figure 4.116: L2CAP/LSC/BI-05-C [Mismatched Service Type, Guaranteed, BR/EDR ERTM Channel] MSC

• Expected Outcome

Pass verdict

The IUT rejects mismatched L2CAP_CONFIGURATION_RSP by sending an L2CAP_DISCONNECTION_REQ.

L2CAP/LSC/BV-06-C [Remote Failed on Guaranteed, BR/EDR ERTM Channel]

• Test Purpose

Verify that the IUT closes the channel if it sends a Configuration request containing an Extended Flow Specification with service type “Guaranteed” and after receiving a Configuration Response with result “Pending” it receives a Configuration request packet with a “Failure” result.

See test case [L2CAP/LSC/BV-03-C \[Premature Success in Configuration Response, BR/EDR ERTM Channel\]](#).

• Reference

[8] 7.1.3

• Initial Condition

- An ACL connection has been established by the Lower Tester.
- L2CAP channel is established over BR/EDR using ERTM with the Extended Flow Specification bit set in the IUT’s Extended Features Mask.
- The IUT is in CONFIG state.

• Test Procedure

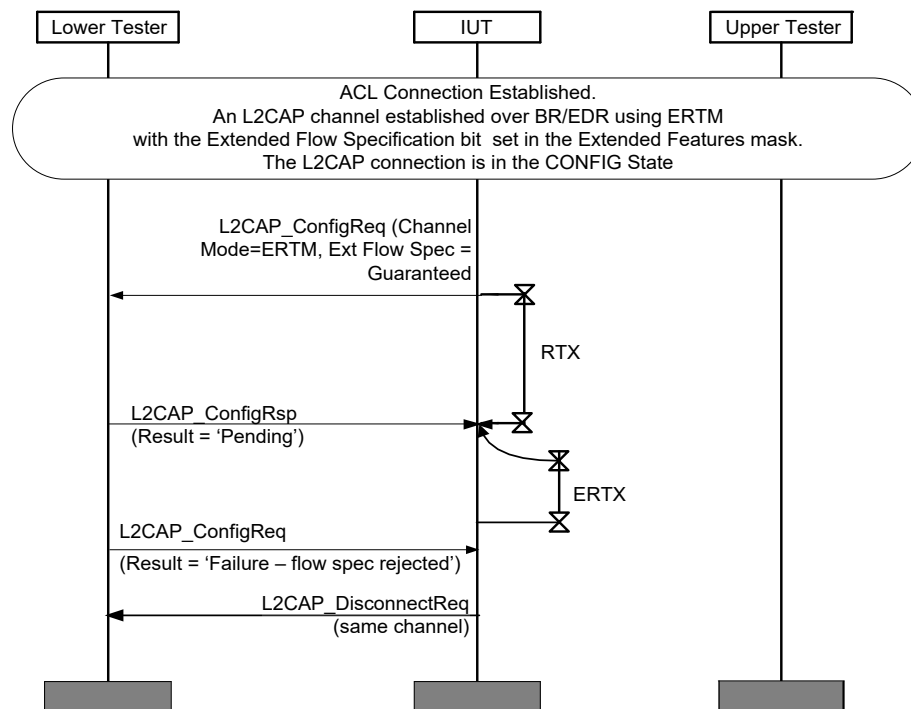

Figure 4.117: L2CAP/LSC/BV-06-C [Remote Failed on Guaranteed, BR/EDR ERTM Channel] MSC

• Expected Outcome

Pass verdict

The IUT detects L2CAP_CONFIGURATION_RSP indicating ‘no resources’ (failure) by sending an L2CAP_DISCONNECTATION_REQ.

L2CAP/LSC/BV-07-C [Normal Lock Step Configuration Process for Best Effort, AMP Channel]

- Test Purpose

Verify that the IUT performs the Lock-step Configuration process including sending a properly formatted Enhanced Flow Specification option for service type “Best Effort”.
- Reference

[8] 7.1.3
- Initial Condition
 - An ACL connection has been established by the Lower Tester.
 - The IUT has established that the peer L2CAP entity supports Lockstep Configuration Process using the Information Request/Response [Extended Features] mechanism.
 - L2CAP channel is connected over an AMP controller which can support guaranteed logical links.
 - The IUT is in CONFIG state.
- Test Procedure

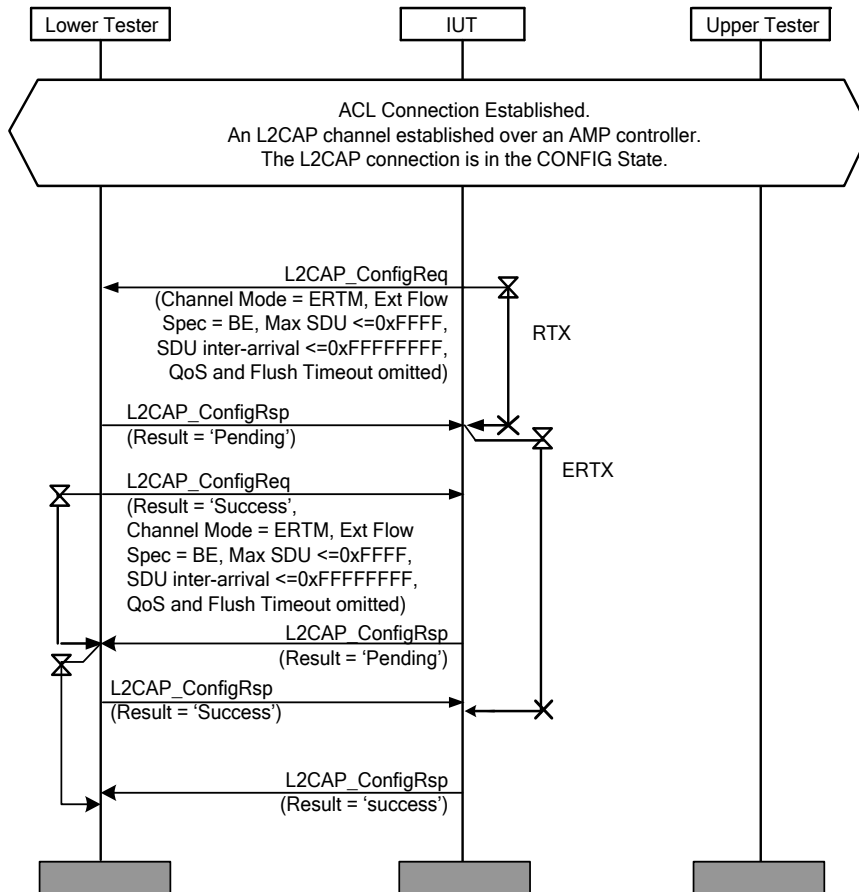

Figure 4.118: L2CAP/LSC/BV-07-C [Normal Lock Step Configuration Process for Best Effort, AMP Channel] MSC

- Expected Outcome

Pass verdict

The IUT sends an L2CAP_CONFIGURATION_REQ packet with Extended Flow Spec options for BE.

The IUT responds to an L2CAP_CONFIGURATION_REQ packet, including Extended Flow Spec options for BE, with status pending and can correctly receive a configuration response from the Lower Tester with the result = "Pending" before its RTX timer expires.

The IUT sends an L2CAP_CONFIGURATION_RSP packet with status success after reception of L2CAP_CONFIGURATION_RSP with status pending can correctly receive the configuration response from the Lower Tester with the result = "Success" before its ERTX timer expires.

L2CAP/LSC/BV-08-C [Normal Lock Step Configuration Process for Guaranteed, AMP Channel]

- Test Purpose

Verify that the IUT performs the Lock-step Configuration process including sending a properly formatted Enhanced Flow Specification option for service type "Guaranteed".

- Reference

[8] 7.1.3

- Initial Condition

- An ACL connection has been established by the Lower Tester.
- The IUT has established that the peer L2CAP entity supports Lockstep Configuration Process using the Information Request/Response [Extended Features] mechanism.
- L2CAP channel is connected over an AMP controller which can support guaranteed logical links.
- The IUT is in CONFIG state.

- Test Procedure

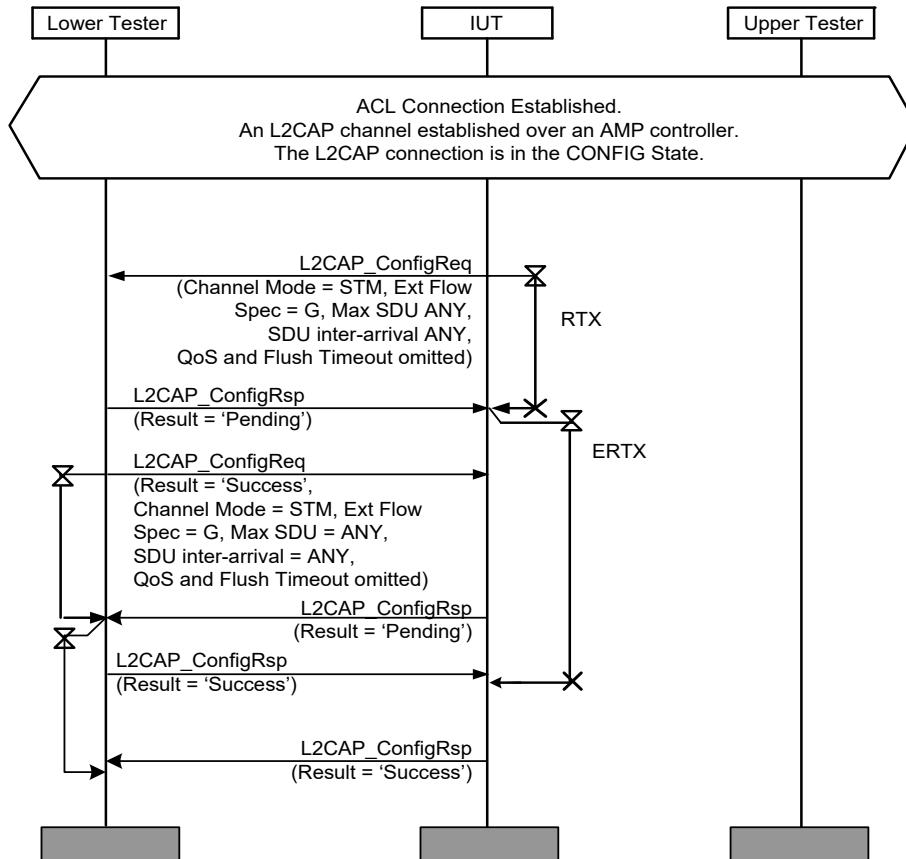

Figure 4.119: L2CAP/LSC/BV-08-C [Normal Lock Step Configuration Process for Guaranteed, AMP Channel] MSC

- Expected Outcome

Pass verdict

The channel is established.

The IUT sends an L2CAP_CONFIGURATION_REQ packet with Extended Flow Spec options for guaranteed service type.

The IUT responds to an L2CAP_CONFIGURATION_REQ packet with status pending before its RTX timer expires.

The IUT sends an L2CAP_CONFIGURATION_RSP packet with status success after reception of L2CAP_CONFIGURATION_RSP with status pending can correctly receive the configuration response from the Lower Tester with the result = “Success” before its ERTX timer expires.

L2CAP/LSC/BV-09-C [Premature Success in Configuration Response, AMP Channel]

- Test Purpose

Verify that the IUT closes the channel if it receives a Configuration response packet with result “Success” before receiving a Configuration response packet with result “Pending”.

- Reference

[8] 7.1.3

- Initial Condition
 - An ACL connection has been established by the Lower Tester.
 - L2CAP channel is connected over an AMP controller which can support guaranteed logical links.
 - The IUT is in CONFIG state.
- Test Procedure

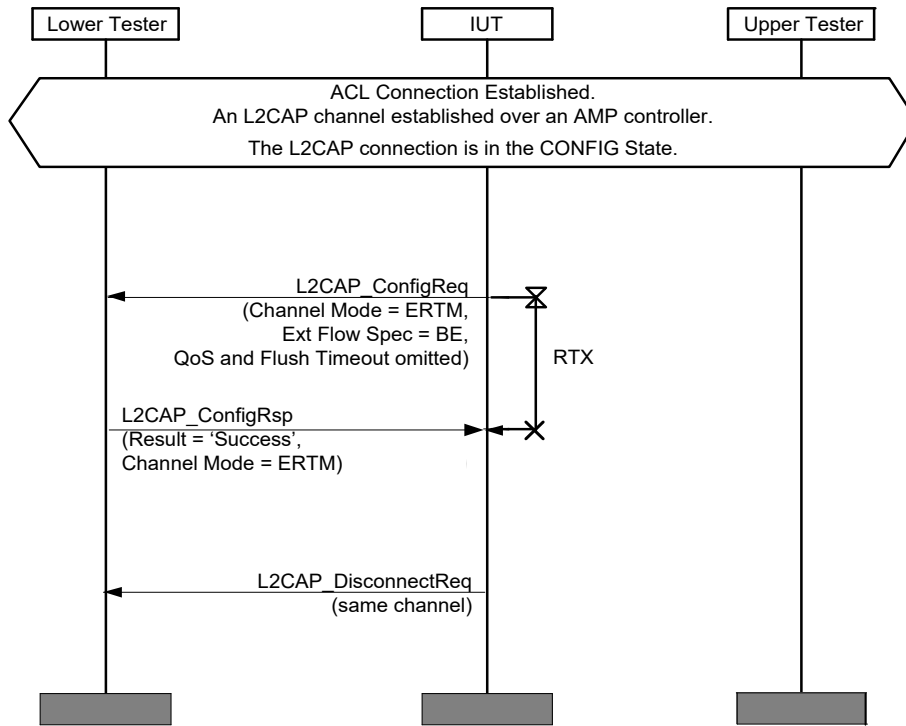

Figure 4.120: L2CAP/LSC/BV-09-C [Premature Success in Configuration Response, AMP Channel] MSC

- Expected Outcome

Pass verdict

The IUT stays in CONFIG state after receiving L2CAP_CONFIGURATION_RSP with results before receiving L2CAP_CONFIGURATION_RSP with “Pending” status. IUT sends L2CAP_DISCONNECTION_REQ with the same channel specified.

L2CAP/LSC/BI-10-C [Mismatched Service Type, Best Effort, AMP Channel]

- Test Purpose

Verify that the IUT closes the channel if it sends a Configuration request containing an Extended Flow Specification with service type “Best Effort” and receives a Configuration request packet with an Extended Flow Specification containing service type “Guaranteed”.

See test case [L2CAP/LSC/BV-03-C \[Premature Success in Configuration Response, BR/EDR ERTM Channel\]](#).

- Reference

[8] 7.1.3

- Initial Condition
 - An ACL connection has been established by the Lower Tester.
 - L2CAP channel is connected over an AMP controller which can support guaranteed logical links.
 - The IUT is in CONFIG state.
- Test Procedure

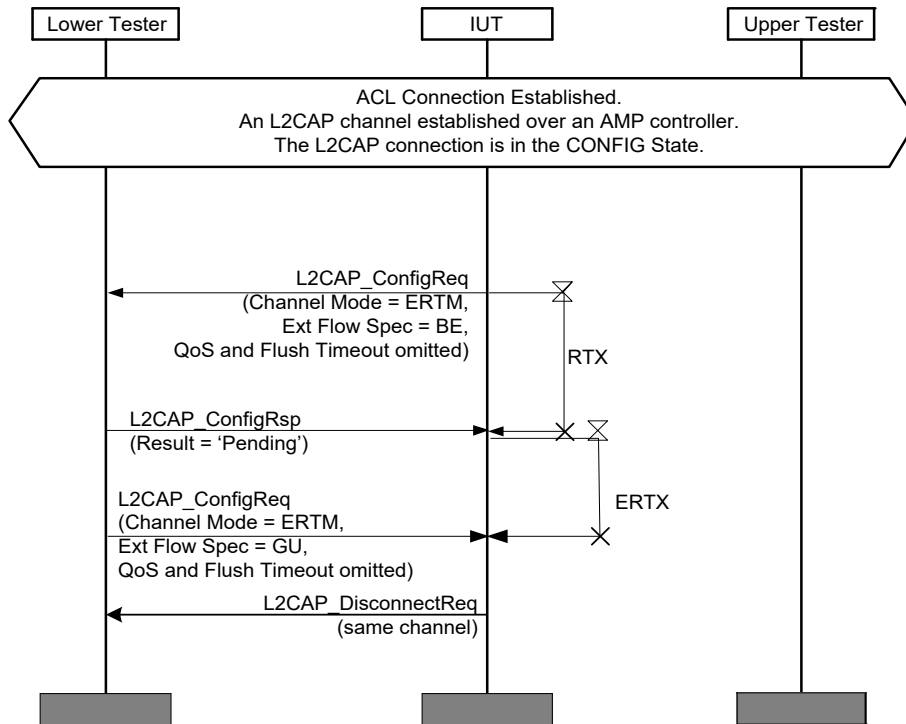

Figure 4.121: L2CAP/LSC/BV-10-I [Mismatched Service Type, Best Effort, AMP Channel] MSC

- Expected Outcome

Pass verdict

The IUT rejects mismatched L2CAP_CONFIGURATION_RSP by sending an L2CAP_DISCONNECTION_REQ.

L2CAP/LSC/BI-11-C [Mismatched Service Type, Guaranteed, AMP Channel]

- Test Purpose

Verify that the IUT closes the channel if it sends a Configuration request containing an Extended Flow Specification with service type “Guaranteed” and receives a Configuration request packet with an Extended Flow Specification containing service type “Best Effort”.

See test case [L2CAP/LSC/BV-03-C \[Premature Success in Configuration Response, BR/EDR ERTM Channel\]](#).

- Reference

[8] 7.1.3

- Initial Condition
 - An ACL connection has been established by the Lower Tester.
 - L2CAP channel is connected over an AMP controller which can support guaranteed logical links.
 - The IUT is in CONFIG state.
- Test Procedure

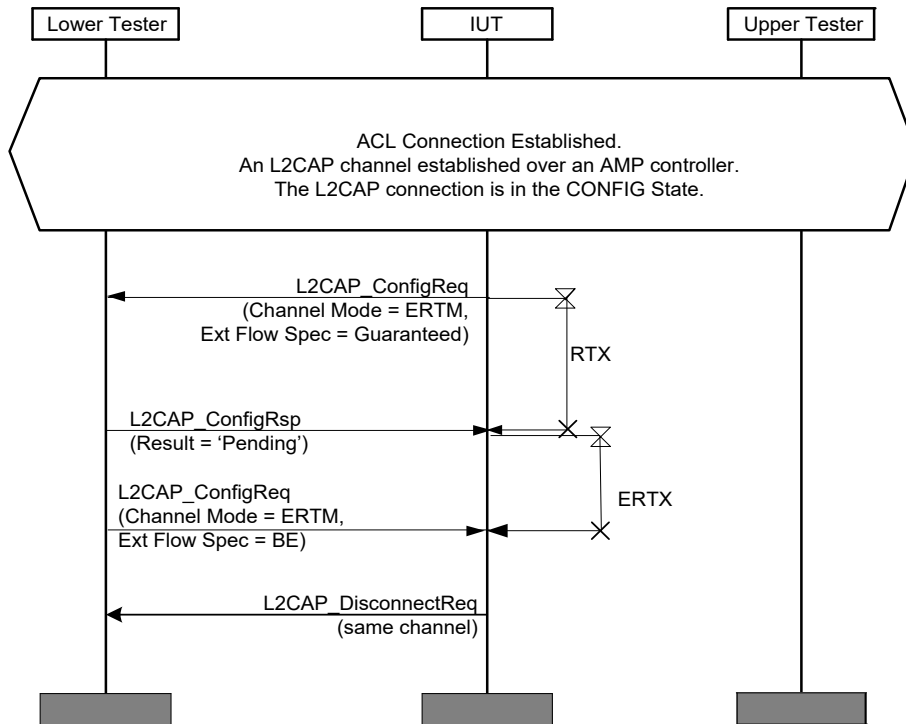

Figure 4.122: L2CAP/LSC/BI-11-C [Mismatched Service Type, Guaranteed, AMP Channel] MSC

- Expected Outcome

Pass verdict

The IUT rejects mismatched L2CAP_CONFIGURATION_RSP by sending an L2CAP_DISCONNECTION_REQ.

L2CAP/LSC/BV-12-C [Remote Failed on Guaranteed, AMP Channel]

- Test Purpose

Verify that the IUT closes the channel if it sends a Configuration request containing an Extended Flow Specification with service type “Guaranteed” and after receiving a Configuration Response with result “Pending” it receives a Configuration request packet with a “Failure” result.

See test case [L2CAP/LSC/BV-03-C \[Premature Success in Configuration Response, BR/EDR ERTM Channel\]](#).

- Reference

[8] 7.1.3

- Initial Condition
 - An ACL connection has been established by the Lower Tester.
 - L2CAP channel is connected over an AMP controller which can support guaranteed logical links.
 - The IUT is in CONFIG state.
- Test Procedure

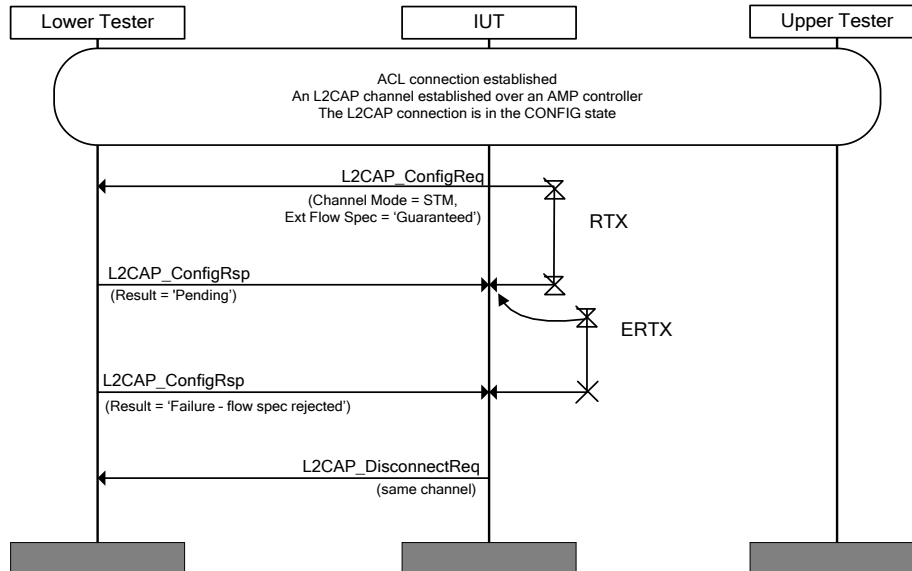

Figure 4.123: L2CAP/LSC/BV-12-C [Remote Failed on Guaranteed, AMP Channel] MSC

- Expected Outcome

Pass verdict

The IUT detects L2CAP_CONFIGURATION_RSP indicating 'no resources' (failure) by sending an L2CAP_DISCONNECTION_REQ.

4.5.12 Create Channel (CCH)

Verify the correct implementation of the create channel request and response of the L2CAP layer.

L2CAP/CCH/BV-01-C [Create Channel Request for an AMP Physical Link]

- Test Purpose

Verify that the IUT can request the creation of an L2CAP channel to run over an existing AMP physical link.
- Reference
 - [1] 4.14, 4.15
 - [8] 6.1, Figure 6.3
- Initial Condition
 - The AMP Physical Link for the Controller ID exists.

- Test Procedure

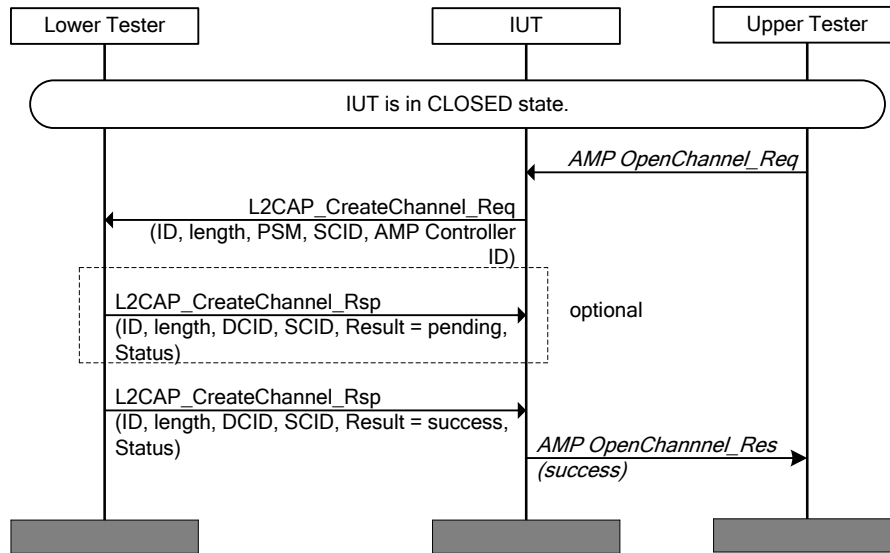

Figure 4.124: L2CAP/CCH/BV-01-C [Create Channel Request for an AMP Physical Link] MSC

- Expected Outcome

Pass verdict

The IUT transmits L2CAP_CREATE_CHANNEL_REQ over the signaling channel using a dynamically allocated SCID, a valid PSM value, and the Controller ID matching the ID for the existing AMP channel.

The IUT enters the OPEN state.

L2CAP/CCH/BV-02-C [Create Channel Request for an AMP Physical Link – Refused]

- Test Purpose

Verify that the IUT can request the creation of an L2CAP channel to run over an existing AMP physical link, and to recover if the request is refused by the Lower Tester (L2CAP create channel response).

- Reference

[1] 4.14, 4.15

[8] 6.1, Figure 6.3

- Initial Condition

- The AMP Physical Link for the Controller ID exists.

- Test Procedure

The 'Connection Refused' code sent by the Lower Tester may include: PSM not supported; Security Block; No Resources; Controller ID not supported.

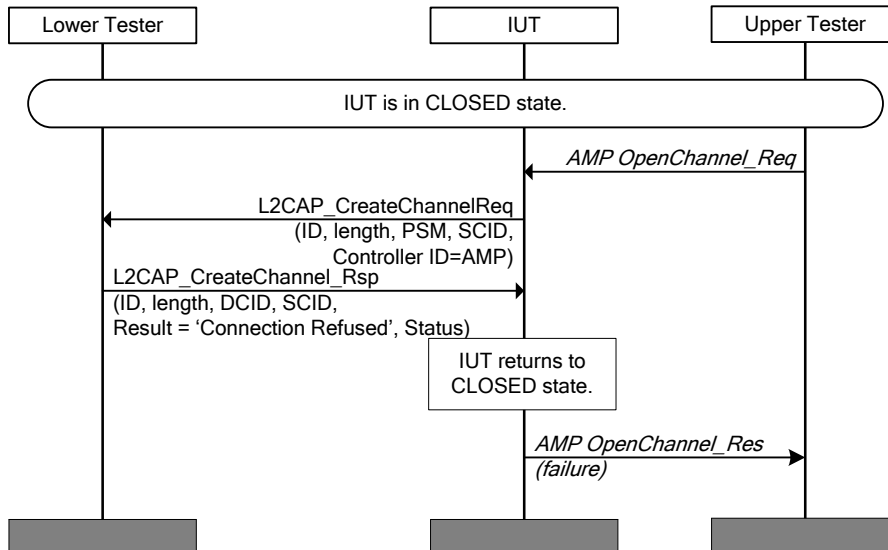

Figure 4.125: L2CAP/CCH/BV-02-C [Create Channel Request for an AMP Physical Link – Refused] MSC

- Expected Outcome

Pass verdict

The IUT transmits L2CAP_CREATE_CHANNEL_REQ over the signaling channel using a dynamically allocated SCID, a valid PSM value, and the Controller ID matching the ID for the existing AMP channel.

The IUT returns to the CLOSED state.

The IUT indicates failure to the Upper Tester.

L2CAP/CCH/BV-03-C [Create Channel Request for an AMP Physical Link – Failed]

- Test Purpose

Verify that the IUT can request the creation of an L2CAP channel to run over an existing AMP physical link, and to recover if the request is accepted (L2CAP create channel response = “Pending”) by the Lower Tester but is failed after initiation.

- Reference

[1] 4.14, 4.15

[8] 6.1, Figure 6.3

- Initial Condition

- The AMP Physical Link for the Controller ID exists.

- Test Procedure

The 'Connection Refused' code sent by the Lower Tester may include: PSM not supported; Security Block; No Resources; Controller ID not supported.

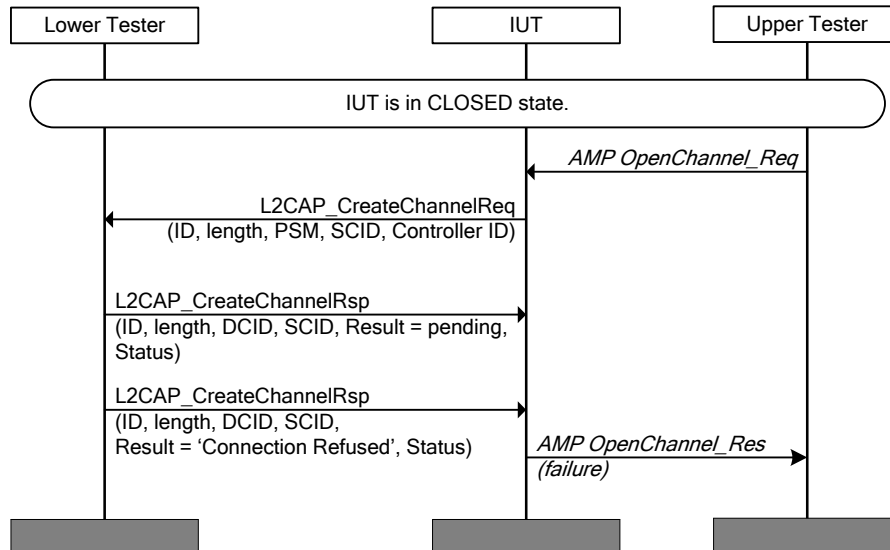

Figure 4.126: L2CAP/CCH/BV-03-C [Create Channel Request for an AMP Physical Link – Failed] MSC

- Expected Outcome

Pass verdict

The IUT transmits L2CAP_CREATE_CHANNEL_REQ over the signaling channel using a dynamically allocated SCID, a valid PSM value, and the Controller ID matching the ID for the existing AMP channel.

The IUT returns to the CLOSED state.

The IUT indicates failure to the Upper Tester.

L2CAP/CCH/BV-04-C [Create Channel Response for an AMP Physical Link]

- Test Purpose

Verify that the IUT can receive and handle a request for connection establishment and configuration of an L2CAP channel to run over an existing AMP physical link.

- Reference

[1] 4.14, 4.15

- Initial Condition

- The AMP Physical Link for the Controller ID exists.

- Test Procedure

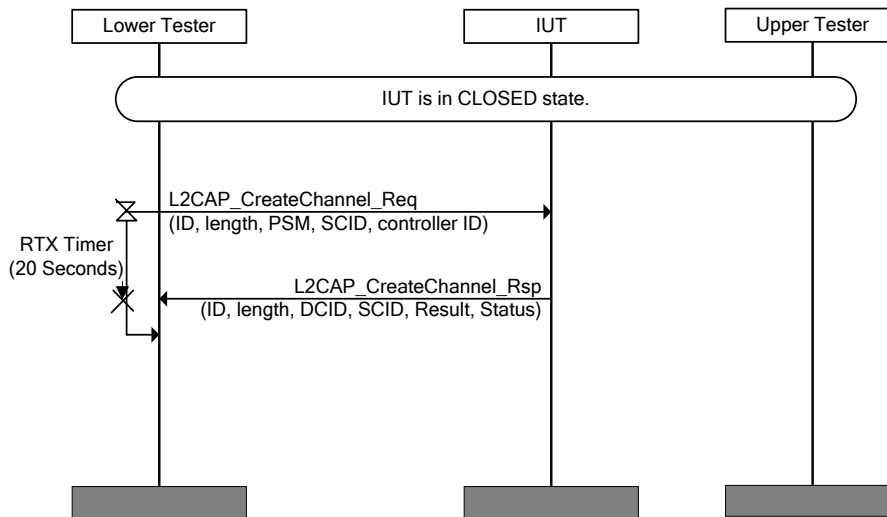

Figure 4.127: L2CAP/CCH/BV-04-C [Create Channel Response for an AMP Physical Link] MSC

- Expected Outcome

Pass verdict

The IUT transmits an L2CAP_CREATE_CHANNEL_RSP with a result code of “Connection Successful” (0x0000) or “Connection Pending” (0x0001) before the Lower Tester RTX timer expires. If the result code = “Connection Pending”, the status code is 0x0000 - 0x0002.

The SCID in the response is equal to the SCID code in the request.

4.5.13 Move Channel (MCH)

Verify the correct implementation of the Move Channel request and response of the L2CAP layer.

L2CAP/MCH/BV-01-C [Move ERTM Channel Request for BR/EDR to AMP – Success]

- Test Purpose

Verify that the IUT can request the move of an L2CAP ERTM channel from a BR/EDR link to an AMP link. If the operation is successful, the channel is in state OPEN over the AMP link.

- Reference

[1] 4.16, 4.17, 4.18, 9.2

- Initial Condition

- An L2CAP ERTM channel exists between the IUT and the Lower Tester in OPEN state.
- The AMP Physical Link exists.
- I(out) outgoing I-frames and I(in) incoming I-frames have been sent and received by the IUT over the channel after it was opened and before the test is executed.

- Test Procedure

Figure 4.128 assumes I(out) and I(in) are 0. The actual values of N(S) and N(R) for both incoming and outgoing traffic must take the number of previously sent and received I-frames into account.

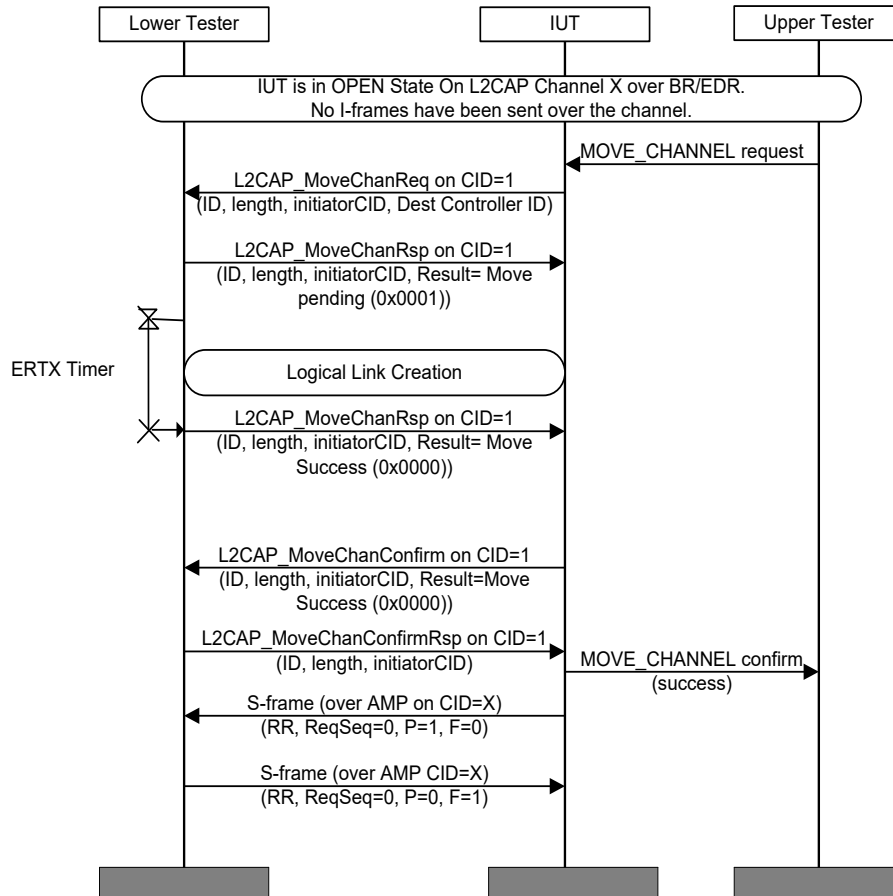

Figure 4.128: L2CAP/MCH/BV-01-C [Move ERTM Channel Request for BR/EDR to AMP – Success] MSC

- Test Condition

The Lower Tester responds with a result field = “Move Pending” and configures the new AMP channel so the channel can be move from BR/EDR to AMP.

- Expected Outcome

Pass verdict

The IUT transmits an L2CAP_MOVE_CHANNEL_CONFIRMATION_REQ with a result code = “Move Success” (0x0000). After it receives the L2CAP_MOVE_CHANNEL_CONFIRMATION_RSP from the Lower Tester, it sends a Receiver Ready message over the new AMP link on the same CID as before the move. The IUT does not transmit any I-frames between the Move Channel Request and RR packets.

L2CAP/MCH/BV-02-C [Move ERTM Channel Request for BR/EDR to AMP – Refused]

• Test Purpose

Verify that the IUT can request the move of an L2CAP ERTM channel from a BR/EDR link to an AMP link, and recover if the Lower Tester refuses the move. In this case the channel remains in state OPEN over the BR link.

• Reference

[1] 4.16, 4.17, 4.18, 9.2

• Initial Condition

- An L2CAP ERTM channel exists between the IUT and the Lower Tester in OPEN state.
- The AMP Physical Link exists.
- I(out) outgoing I-frames and I(in) incoming I-frames have been sent and received by the IUT over the channel after it was opened and before the test is executed.

• Test Procedure

Figure 4.129 assumes I(out) and I(in) are 0. The actual values of N(S) and N(R) for both incoming and outgoing traffic must take the number of previously sent and received I-frames into account.

The 'Move Refused' result code sent by the Lower Tester may include: Controller ID not supported; new Controller ID is same as old Controller ID; configuration not supported; channel not allowed to be moved.

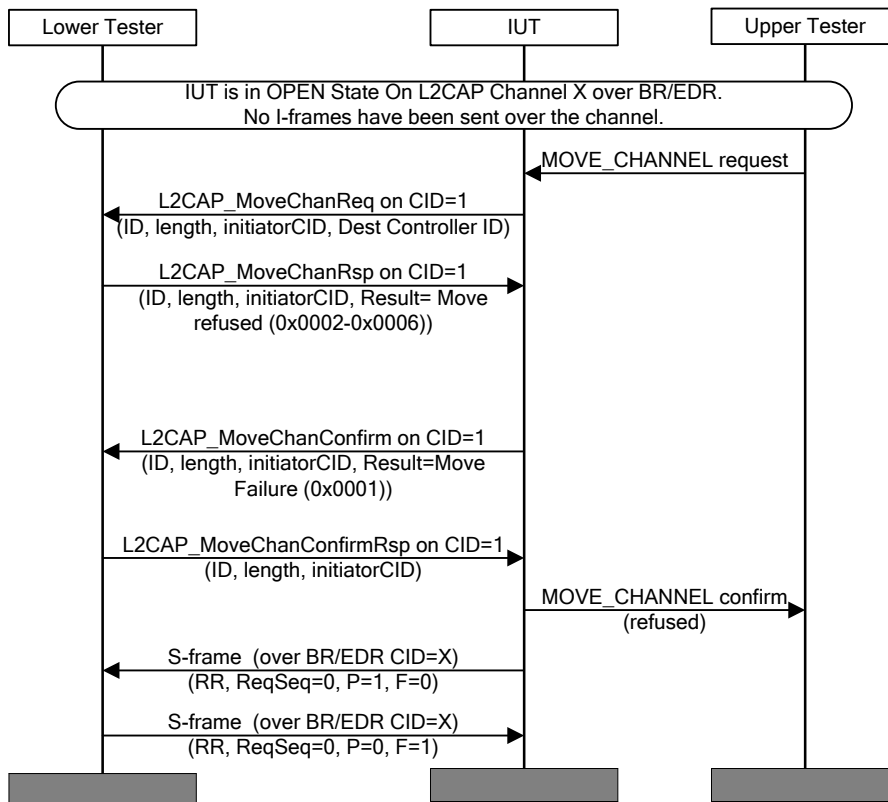

Figure 4.129: L2CAP/MCH/BV-02-C [Move ERTM Channel Request for BR/EDR to AMP – Refused] MSC

- Test Condition

The Lower Tester responds with result= "Move Refused" so that the Move Channel Request from the IUT fails.

- Expected Outcome

Pass verdict

The IUT transmits an L2CAP_MOVE_CHANNEL_CONFIRMATION_REQ packet with a result code of "Move failure – one or both sides refuse" (0x0001) and it sends a Receiver Ready message over the BR/EDR link on the same CID as before the move attempt. The IUT does not transmit any I-frames between the Move Channel Request and RR packets.

L2CAP/MCH/BV-03-C [Move ERTM Channel Request for BR/EDR to AMP – AMP Fail]

- Test Purpose

Verify that the IUT can request the move of an L2CAP channel from a BR/EDR link to an AMP link, and recover if the AMP channel creation fails. In this case the channel remains in state OPEN over the BR link.

- Reference

[1] 4.16, 4.17, 4.18, 9.2

- Initial Condition

- An L2CAP channel exists between the IUT and the Lower Tester in OPEN state.
- The AMP Physical Link exists.
- I(out) outgoing I-frames and I(in) incoming I-frames have been sent and received by the IUT over the channel after it was opened and before the test is executed.

- Test Procedure

Figure 4.130 assumes I(out) and I(in) are 0. The actual values of N(S) and N(R) for both incoming and outgoing traffic must take the number of previously sent and received I-frames into account.

The channel move is not successful. The IUT and the Lower Tester return to the BR/EDR channel after the unsuccessful move attempt.

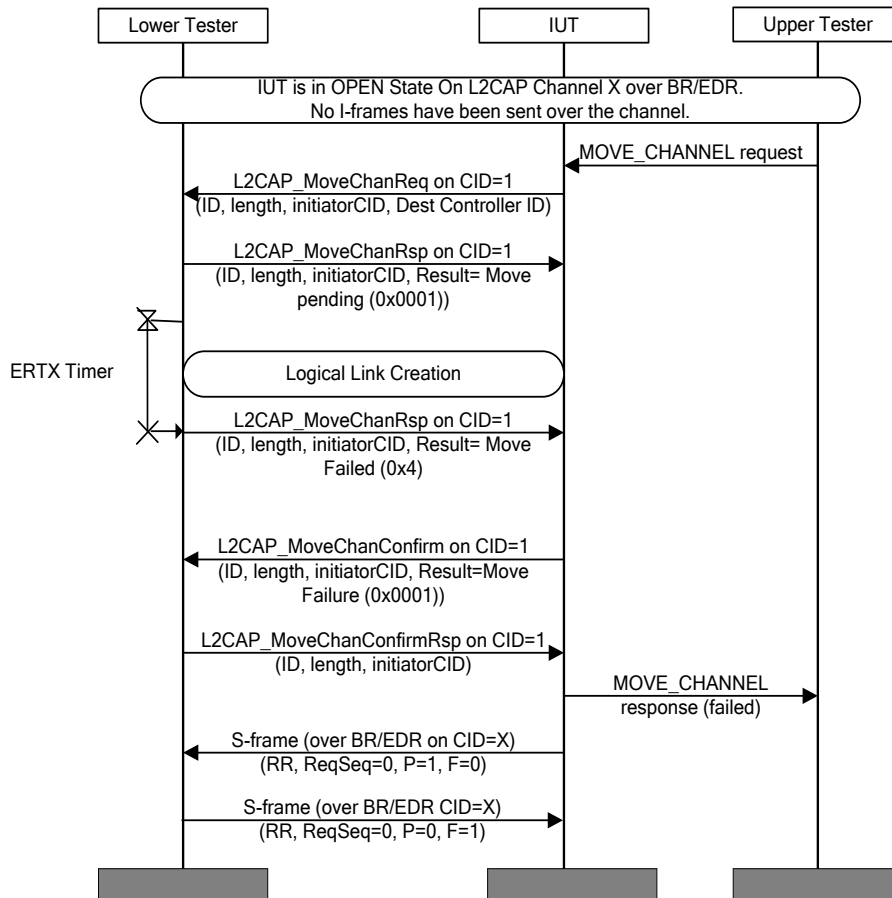

Figure 4.130: L2CAP/MCH/BV-03-C [Move ERTM Channel Request for BR/EDR to AMP – AMP Fail] MSC

- Test Condition

The Lower Tester responds with a result field = “Move Pending” and configures the new AMP channel so the channel can be move from BR/EDR to AMP. However, the AMP channel configuration fails, so the Lower Tester replies with a failure indication.

- Expected Outcome

Pass verdict

The IUT transmits an L2CAP_MOVE_CHANNEL_CONFIRMATION_REQ packet with a result code of “Move failure – one or both sides refuse” (0x0001) and it sends a Receiver Ready message over the BR/EDR link on the same CID as before the move attempt. The IUT does not transmit any I-frames between the Move Channel Request and RR packets.

L2CAP/MCH/BV-04-C [Move ERTM Channel Request for AMP to BR/EDR – Success]

- Test Purpose

Verify that the IUT can request the move of an L2CAP ERTM channel from an AMP link to a BR link. If the operation is successful, the channel has to be in state OPEN over the BR link.

- Reference

[1] 4.16, 4.17, 9.2

- Initial Condition
 - The IUT is in OPEN state.
 - I(out) outgoing I-frames and I(in) incoming I-frames have been sent and received by the IUT over the channel after it was opened and before the test is executed.
- Test Procedure

Figure 4.131 assumes I(out) and I(in) are 0. The actual values of N(S) and N(R) for both incoming and outgoing traffic must take the number of previously sent and received I-frames into account.

The IUT and the Lower Tester move to the new BR/EDR channel successfully.

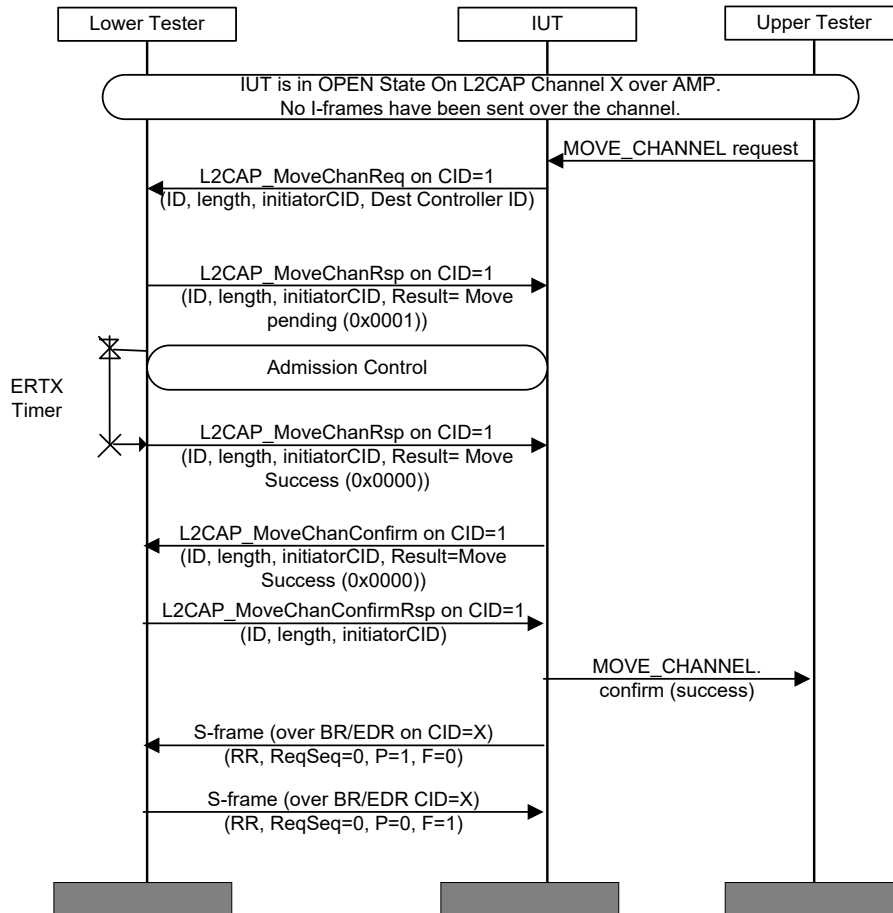

Figure 4.131: L2CAP/MCH/BV-04-C [Move ERTM Channel Request for AMP to BR/EDR – Success] MSC

- Expected Outcome

Pass verdict

The IUT transmits an L2CAP_MOVE_CHANNEL_CONFIRMATION_REQ with a result code of “Move Success” (0x0000). After it receives an L2CAP_MOVE_CHANNEL_CONFIRMATION_RSP from the Lower Tester, it sends a Receiver Ready message over the new BR/EDR link on the same CID as before the move.

The IUT does not transmit any I-frames between the Move Channel Request and RR packets.

L2CAP/MCH/BV-05-C [Move ERTM Channel Request for AMP to BR/EDR – Refused]

- Test Purpose

Verify that the IUT can request the move of an L2CAP channel from an AMP link to a BR link.

If the operation is refused by the Lower Tester, the channel remains in state OPEN over the AMP link.
- Reference

[1] 4.16, 4.17, 9.2
- Initial Condition
 - The IUT is in OPEN state.
 - I(out) outgoing I-frames and I(in) incoming I-frames have been sent and received by the IUT over the channel after it was opened and before the test is executed.
- Test Procedure

Figure 4.132 assumes I(out) and I(in) are 0. The actual values of N(S) and N(R) for both incoming and outgoing traffic must take the number of previously sent and received I-frames into account.

The channel move is not successful refused by the Lower Tester. The IUT and the Lower Tester return to the AMP channel after the unsuccessful move attempt.

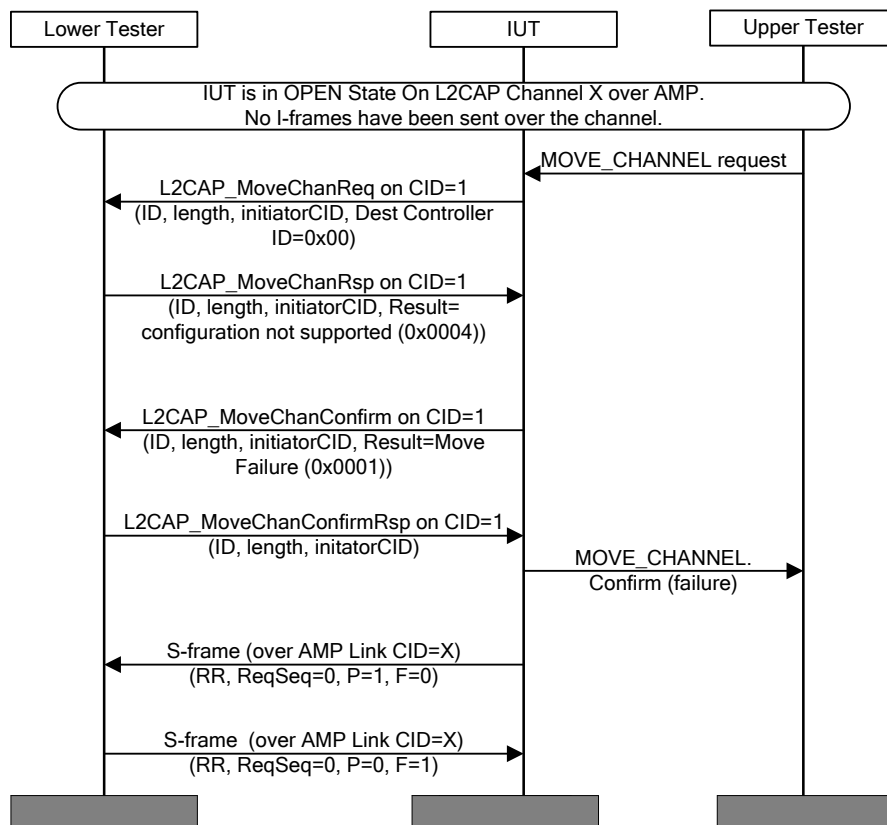

Figure 4.132: L2CAP/MCH/BV-05-C [Move ERTM Channel Request for AMP to BR/EDR – Refused] MSC

- Test Condition

The AMP channel requires service not available on BR/EDR, e.g. much more bandwidth.

- Expected Outcome

Pass verdict

The IUT transmits an L2CAP_MOVE_CHANNEL_CONFIRMATION_REQ packet with a result code of "Move refused - Configuration not supported" (0x0004).

The IUT does not transmit any I-frames between the Move Channel Request and RR packets.

L2CAP/MCH/BV-06-C [Move ERTM Channel Response for BR/EDR to AMP – Success]

- Test Purpose

Verify that the IUT can receive and handle a request to move an L2CAP channel from a BR/EDR link to an AMP link.

- Reference

[1] 4.16, 4.17, 9.2

- Initial Condition

- An L2CAP channel exists between the IUT and the Lower Tester in OPEN state.
- The AMP Physical Link exists.
- I(out) outgoing I-frames and I(in) incoming I-frames have been sent and received by the IUT over the channel after it was opened and before the test is executed.

- Test Procedure

Figure 4.133 assumes I(out) and I(in) are 0. The actual values of N(S) and N(R) for both incoming and outgoing traffic must take the number of previously sent and received I-frames into account.

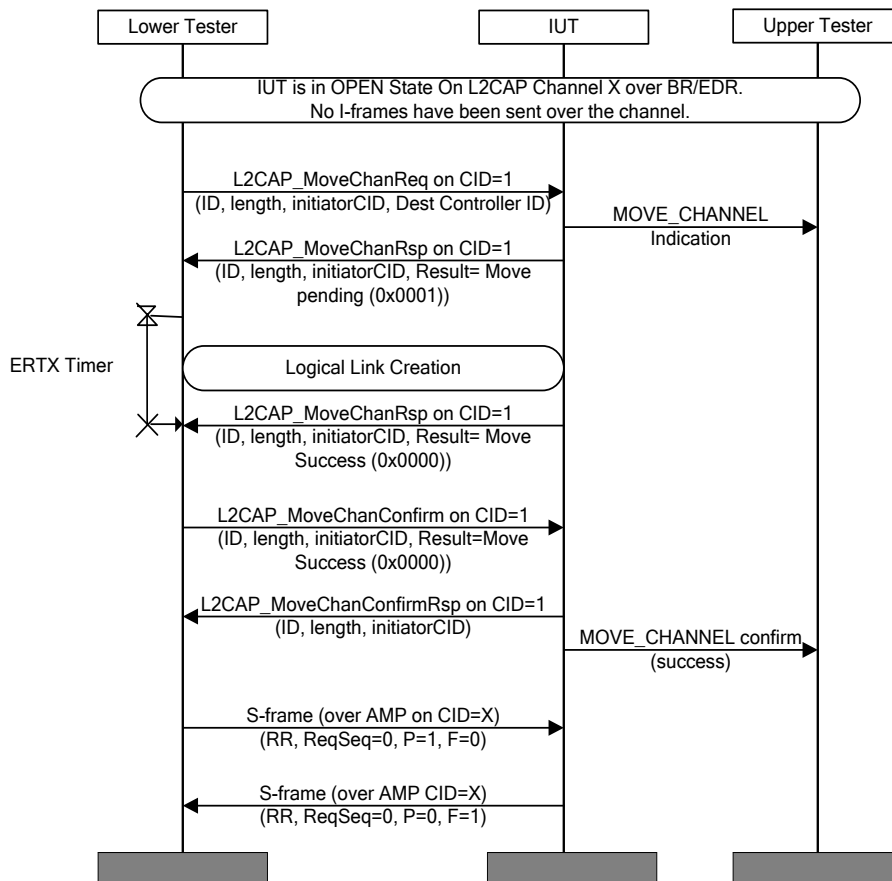

Figure 4.133: L2CAP/MCH/BV-06-C [Move ERTM Channel Response for BR/EDR to AMP – Success] MSC

- Expected Outcome

Pass verdict

The IUT transmits an L2CAP_MOVE_CHANNEL_RSP with a result code of “Move Success” (0x0000) and responds to the RR(P=1) with an RR(F=1, ReqSeq = 0) on the AMP link.

L2CAP/MCH/BV-07-C [Move ERTM Channel Response for BR/EDR to AMP – Failure]

- Test Purpose

Verify that the IUT can receive and handle a request to move an L2CAP channel from a BR/EDR link to an AMP link where the move operation fails.

- Reference

[1] 4.16, 4.17, 9.2

- Initial Condition

- An L2CAP channel exists between the IUT and the Lower Tester in OPEN state.
- The AMP Physical Link exists.
- I(out) outgoing I-frames and I(in) incoming I-frames have been sent and received by the IUT over the channel after it was opened and before the test is executed.

- Test Procedure

Figure 4.134 assumes I(out) and I(in) are 0. The actual values of N(S) and N(R) for both incoming and outgoing traffic must take the number of previously sent and received I-frames into account.

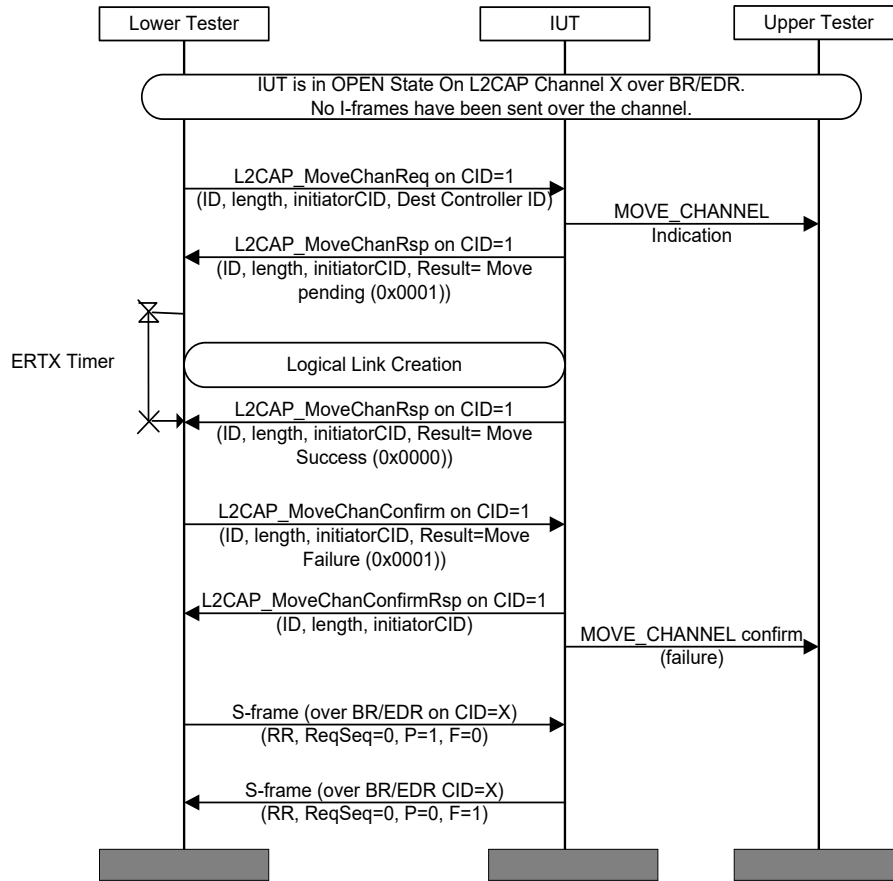

Figure 4.134: L2CAP/MCH/BV-07-C [Move ERTM Channel Response for BR/EDR to AMP – Failure] MSC

- Expected Outcome

Pass verdict

The IUT transmits an L2CAP_MOVE_CHANNEL_RSP a result code of “Move Success” (0x0000) and responds to the RR(P=1) with an RR(F=1, ReqSeq = 0) over the BR/EDR link.

L2CAP/MCH/BV-08-C [Move ERTM Channel Response for AMP to BR/EDR – Success]

- Test Purpose

Verify that the IUT can receive and handle a request to move an L2CAP channel from an AMP link to a BR/EDR link.

- Reference

[1] 4.16, 4.17, 9.2

- Initial Condition

- An L2CAP channel exists between the IUT and the Lower Tester in OPEN state.
- The BR/EDR Physical Link exists.

- I(out) outgoing I-frames and I(in) incoming I-frames have been sent and received by the IUT over the channel after it was opened and before the test is executed.

- Test Procedure

Figure 4.135 assumes I(out) and I(in) are 0. The actual values of N(S) and N(R) for both incoming and outgoing traffic must take the number of previously sent and received I-frames into account.

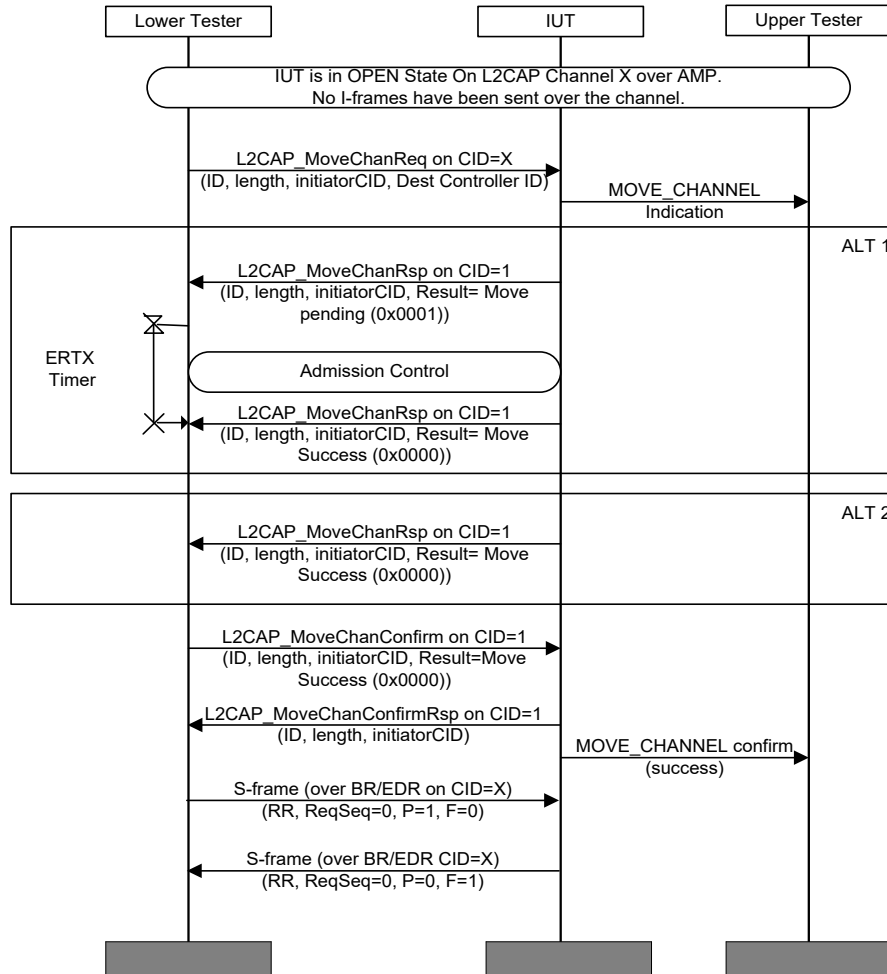

Figure 4.135: L2CAP/MCH/BV-08-C [Move ERTM Channel Response for AMP to BR/EDR – Success] MSC

- Expected Outcome

Pass verdict

The IUT transmits an L2CAP_MOVE_CHANNEL_RSP with result code success (0) and the IUT responds to the RR(P=1) with an RR(F=1, ReqSeq = 0) over the AMP link.

L2CAP/MCH/BV-09-C [Move ERTM Channel Response for AMP to BR/EDR – Failure]

- Test Purpose

Verify that the IUT can receive and handle a request to move an L2CAP channel from an AMP link to a BR/EDR link where the move operation fails.

- Reference

[1] 4.16, 4.17, 9.2



- Initial Condition
 - An L2CAP channel exists between the IUT and the Lower Tester in OPEN state.
 - The BR/EDR Physical Link exists.
 - I(out) outgoing I-frames and I(in) incoming I-frames have been sent and received by the IUT over the channel after it was opened and before the test is executed.
- Test Procedure

Figure 4.136 assumes I(out) and I(in) are 0. The actual values of N(S) and N(R) for both incoming and outgoing traffic must take the number of previously sent and received I-frames into account.

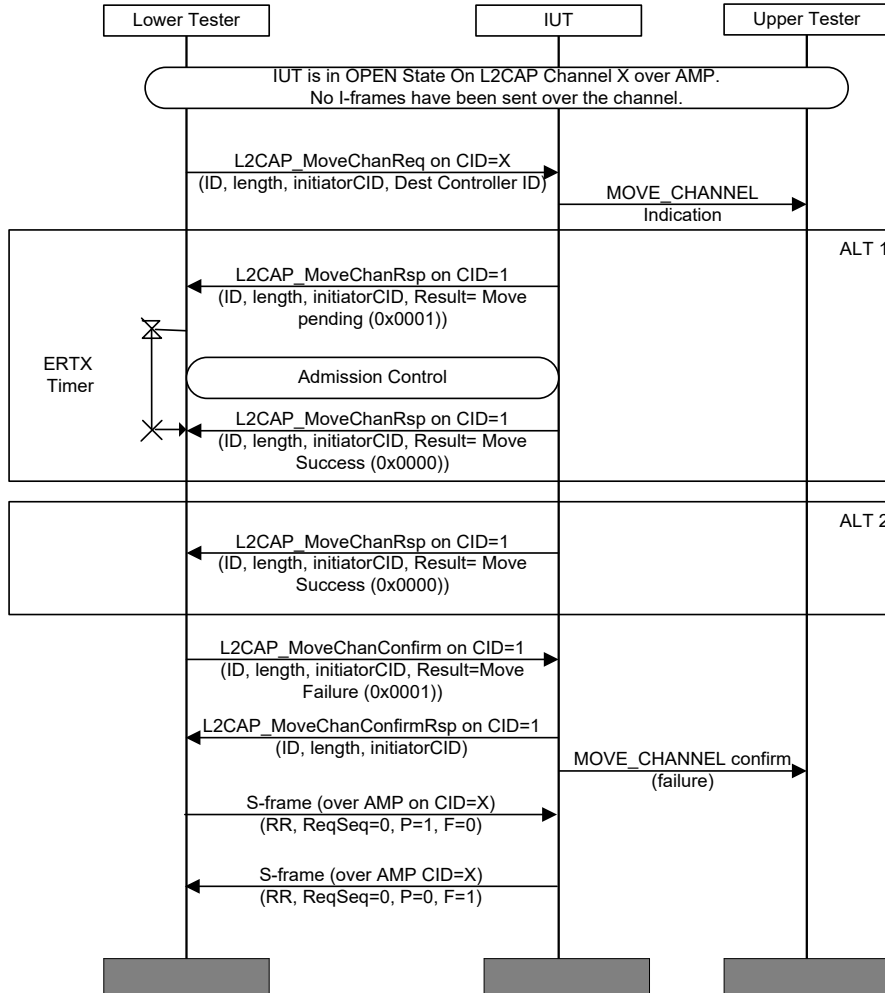

Figure 4.136: L2CAP/MCH/BV-09-C [Move ERTM Channel Response for AMP to BR/EDR – Failure] MSC

- Expected Outcome

Pass verdict

The IUT transmits an L2CAP_MOVE_CHANNEL_RSP with result code of “Move Success” (0x0000) and responds to the RR(P=1) with an RR(F=1, ReqSeq = 0) over the AMP link.

L2CAP/MCH/BV-10-C [Data Transfer while Moving ERTM Channel from BR/EDR to AMP]

- Test Purpose

Verify that the IUT can move the active L2CAP ERTM channel from a BR/EDR link to an AMP link with no data loss above L2CAP.
- Reference

[1] 4.16, 4.17, 9.2
- Initial Condition
 - A BR/EDR L2CAP ERTM channel exists between the IUT and the Lower Tester. There has been data transfer on the channel.
 - The AMP Physical Link exists.
 - I(out) outgoing I-frames and I(in) incoming I-frames have been sent and received by the IUT over the channel after it was opened and before the test is executed.
- Test Procedure

Figure 4.137 assumes I(out) and I(in) are 0. The actual values of N(S) and N(R) for both incoming and outgoing traffic must take the number of previously sent and received I-frames into account.

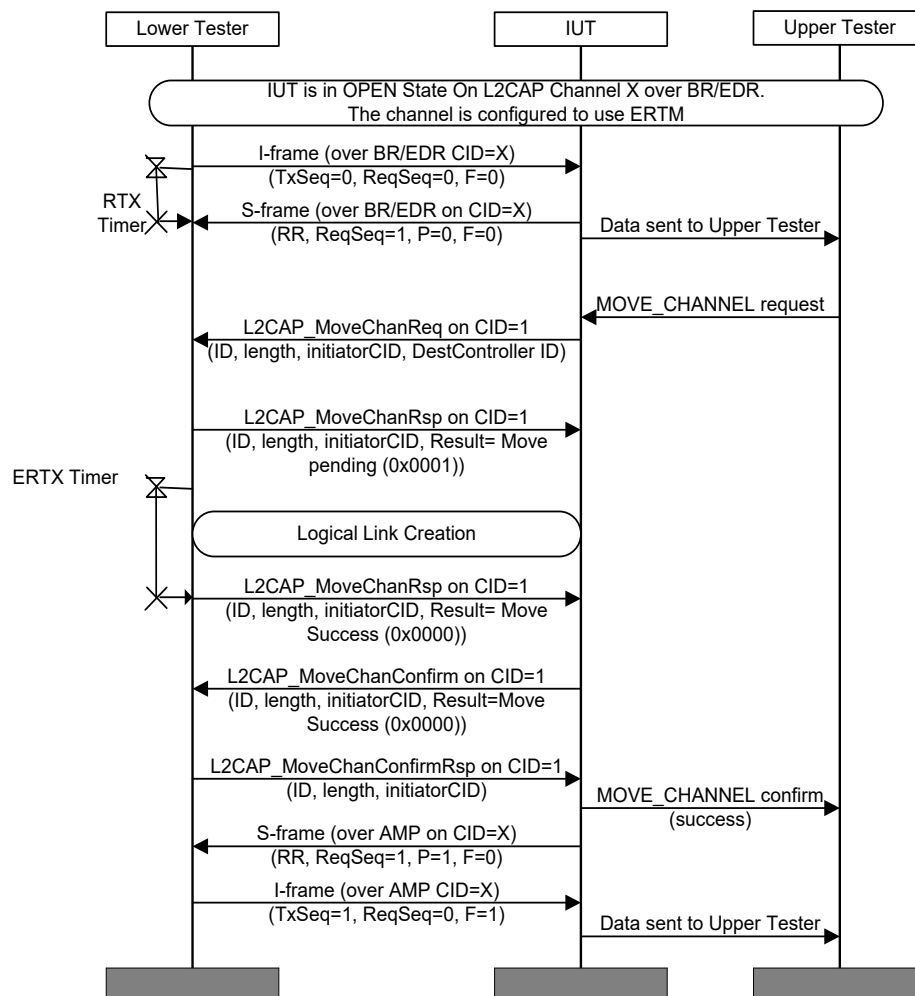

Figure 4.137: L2CAP/MCH/BV-10-C [Data Transfer while Moving ERTM Channel from BR/EDR to AMP] MSC

- Expected Outcome

Pass verdict

The move operation is successful, the IUT transmits a Receiver Ready packet over the new AMP channel at the end of the move with ReqSeq = 1.

L2CAP/MCH/BV-11-C [Data Transfer while Moving ERTM Channel from BR/EDR to AMP – Unacknowledged Data]

- Test Purpose

Verify that the IUT can move the active L2CAP channel from a BR/EDR link to an AMP link with no data loss above L2CAP, and recover from data sent before the move but not yet acknowledged by the Lower Tester.

- Reference

[1] 4.16, 4.17, 9.2

- Initial Condition

- A BR/EDR L2CAP ERTM channel exists between the IUT and the Lower Tester. There has been data transfer on the channel.
- The AMP Physical Link exists.
- I(out) outgoing I-frames and I(in) incoming I-frames have been sent and received by the IUT over the channel after it was opened and before the test is executed.

- Test Procedure

Figure 4.138 assumes I(out) and I(in) are 0. The actual values of N(S) and N(R) for both incoming and outgoing traffic must take the number of previously sent and received I-frames into account.

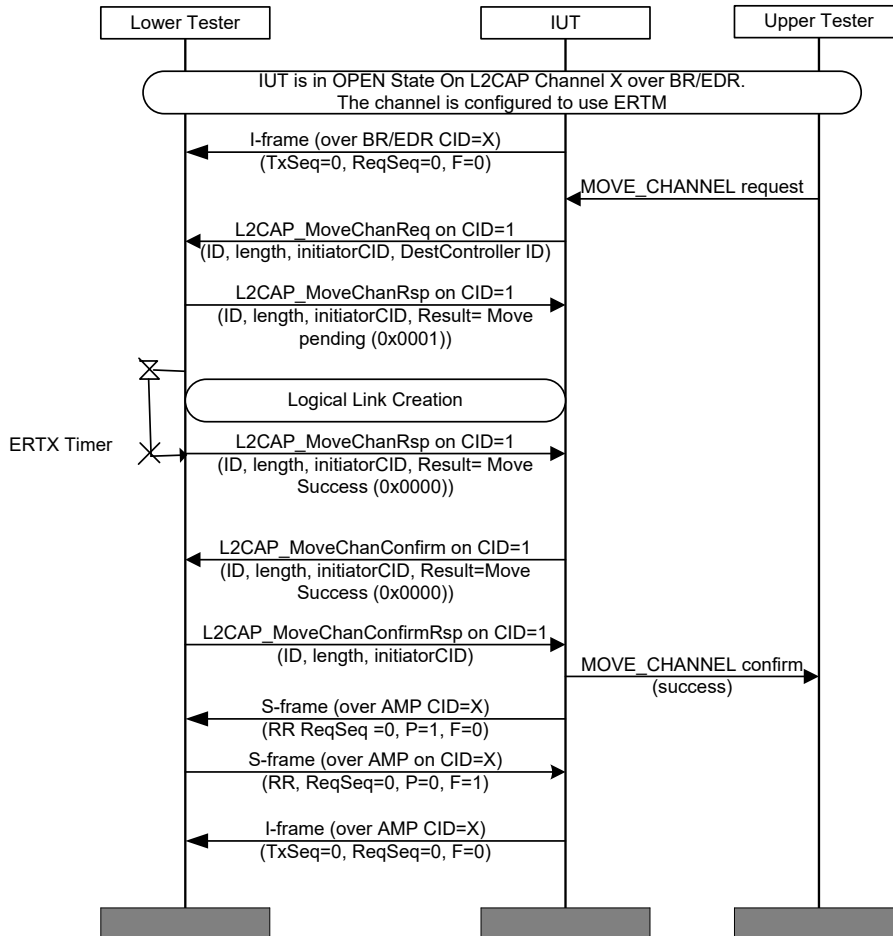

Figure 4.138: L2CAP/MCH/BV-11-C [Data Transfer while Moving ERTM Channel from BR/EDR to AMP – Unacknowledged Data] MSC

- Expected Outcome

Pass verdict

The move operation is successful, the IUT transmits an RR(P=1, ReqSeq = 0) over the new AMP channel at the end of the move and it retransmits the I-frame over the new AMP channel when told by the Lower Tester.

L2CAP/MCH/BV-12-C [Data Transfer while Moving ERTM Channel from AMP to BR/EDR]

- Test Purpose

Verify that the IUT can move the active L2CAP channel from an AMP link to a BR/EDR link with no data loss above L2CAP.

- Reference

[1] 4.16, 4.17, 9.2

- Initial Condition
 - An AMP L2CAP ERTM channel exists between the IUT and the Lower Tester. There has been data transfer on the channel.
 - The AMP Physical Link exists.
 - I(out) outgoing I-frames and I(in) incoming I-frames have been sent and received by the IUT over the channel after it was opened and before the test is executed.
- Test Procedure

Figure 4.139 assumes I(out) and I(in) are 0. The actual values of N(S) and N(R) for both incoming and outgoing traffic must take the number of previously sent and received I-frames into account.

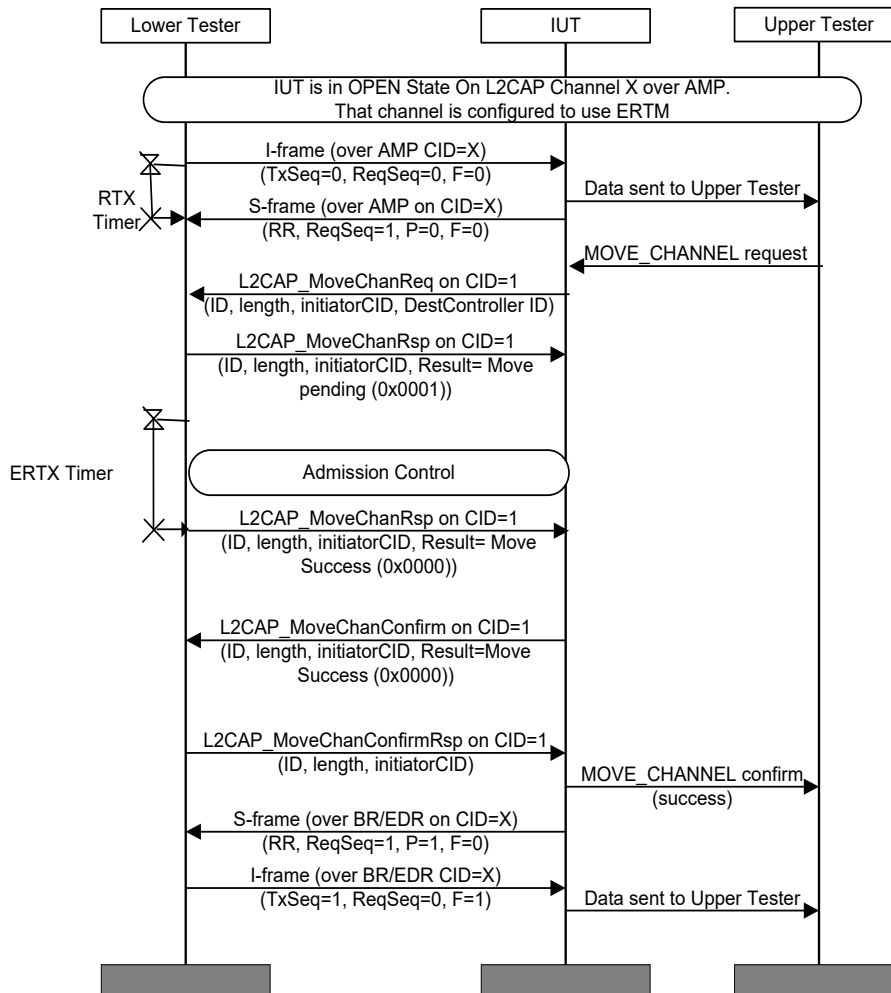

Figure 4.139: L2CAP/MCH/BV-12-C [Data Transfer while Moving ERTM Channel from AMP to BR/EDR] MSC

- Test Condition

In order for the Lower Tester to send an I-frame in response to the RR(P=1) at the end of the test it must be pending before the RR(P=1) is received.

- Expected Outcome

Pass verdict

The move operation is successful, the IUT sends an RR(P=1, ReqSeq=0) over the BR/EDR link at the end of the move and passes received data to the Upper Tester.

L2CAP/MCH/BV-13-C [Data Transfer while Moving ERTM Channel from AMP to BR/EDR – Unacknowledged Data]

- Test Purpose

Verify that the IUT can move the active L2CAP channel from an AMP link to a BR/EDR link with no data loss above L2CAP, and recover from data sent before the move but not yet acknowledged by the Lower Tester.

- Reference

[1] 4.16, 4.17, 9.2

- Initial Condition

- An AMP L2CAP channel exists between the IUT and the Lower Tester. There has been data transfer on the channel.
- The AMP Physical Link exists.
- I(out) outgoing I-frames and I(in) incoming I-frames have been sent and received by the IUT over the channel after it was opened and before the test is executed.

- Test Procedure

Figure 4.140 assumes I(out) and I(in) are 0. The actual values of N(S) and N(R) for both incoming and outgoing traffic must take the number of previously sent and received I-frames into account.

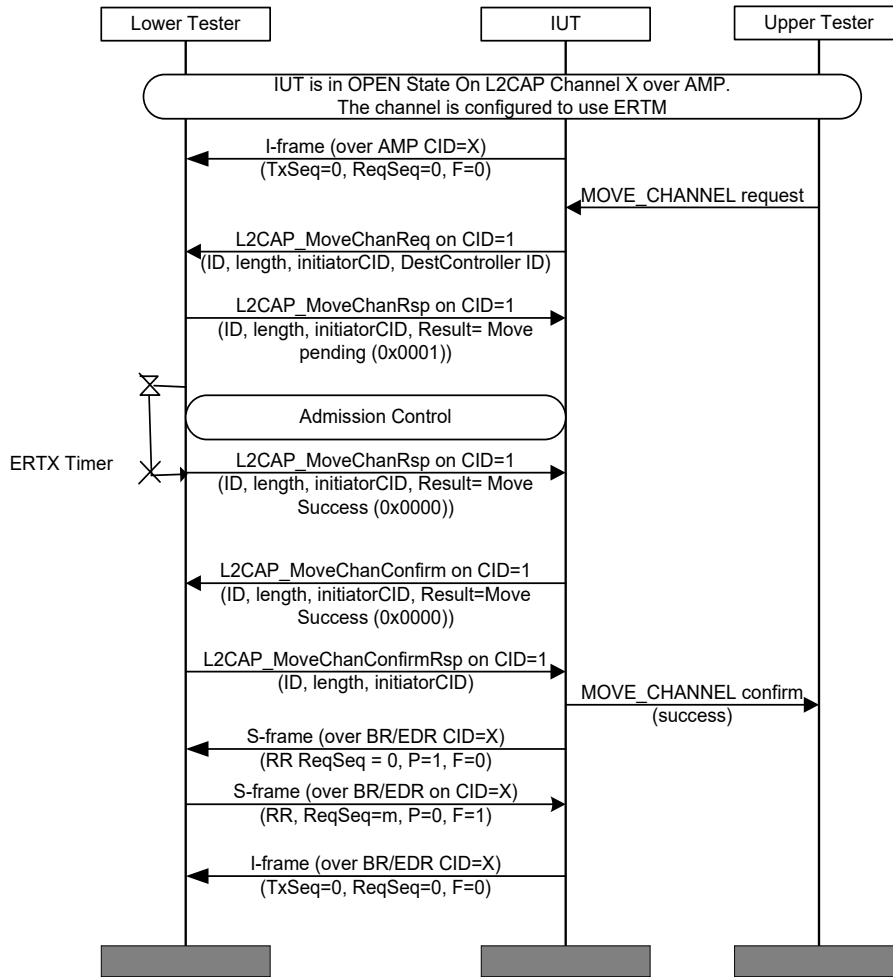

Figure 4.140: L2CAP/MCH/BV-13-C [Data Transfer while Moving ERTM Channel from AMP to BR/EDR – Unacknowledged Data] MSC

- Expected Outcome

Pass verdict

The move operation is successful, the IUT sends an RR(P=1, ReqSeq = 0) over the BR/EDR link at the end of the move operation and retransmits the I-frame over the BR/EDR channel when requested by the Lower Tester.

L2CAP/MCH/BV-14-C [Move Collision – ERTM]

- Test Purpose

Verify that the IUT can properly handle a move collision when both the IUT and Lower Tester attempt to move an ERTM channel from the BR/EDR link to an AMP link simultaneously.

- Reference

[1] 4.16, 4.17, 9.2

- Initial Condition

- An L2CAP ERTM channel exists between the IUT and the Lower Tester. There has been no data transfer on the channel.
- The AMP Physical Link Exists.
- I(out) outgoing I-frames and I(in) incoming I-frames have been sent and received by the IUT over the channel after it was opened and before the test is executed.

- Test Procedure

Figure 4.141 assumes I(out) and I(in) are 0. The actual values of N(S) and N(R) for both incoming and outgoing traffic must take the number of previously sent and received I-frames into account.

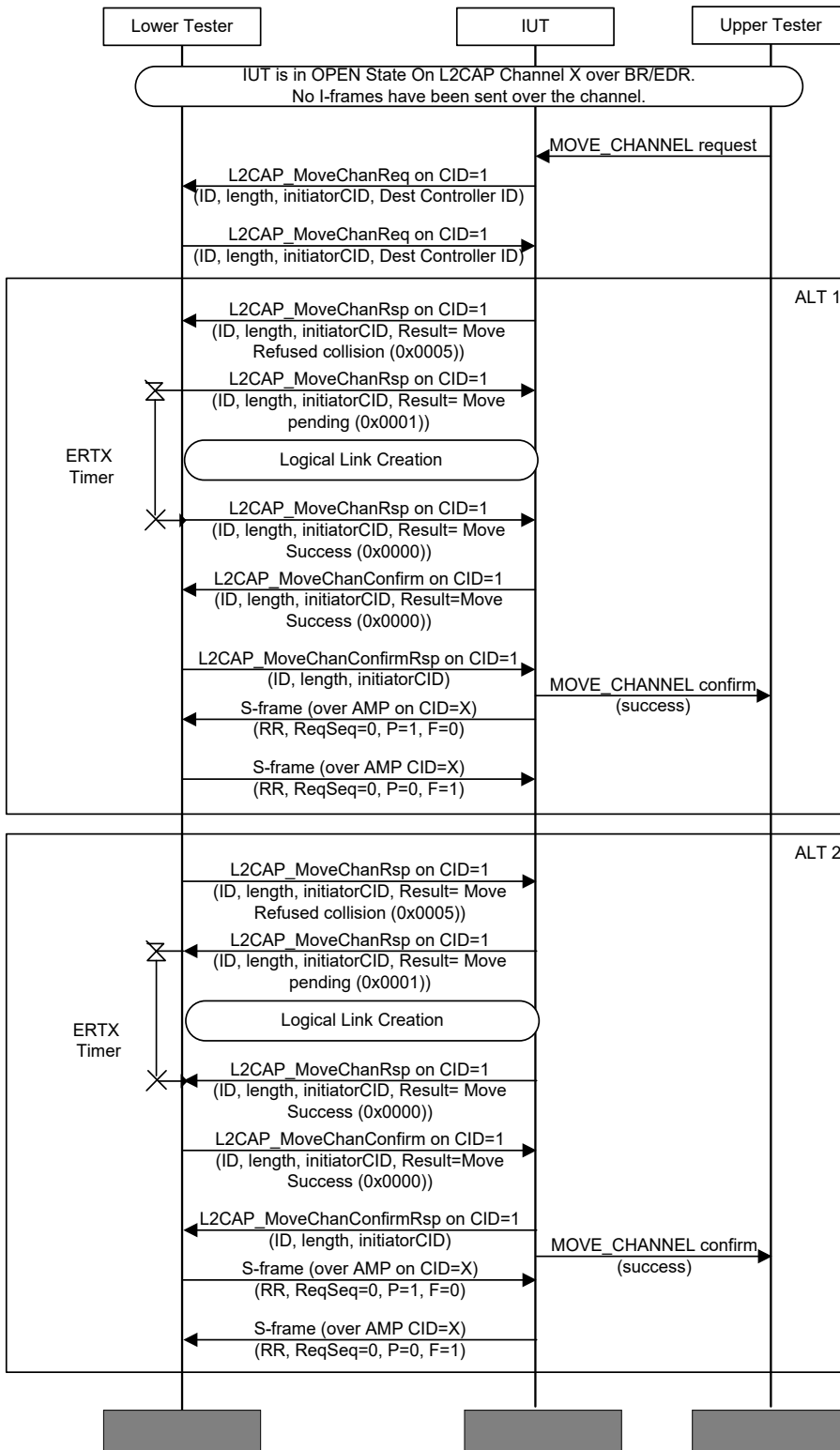

Figure 4.141: L2CAP/MCH/BV-14-C [Move Collision – ERTM] MSC

- Expected Outcome

Pass verdict

Move operation is successful.

ALT1:

The IUT's BD_ADDR is larger than the Lower Tester's BD_ADDR so the IUT sends L2CAP_MOVE_CHANNEL_RSP with result code "Move refused – Move Channel collision" (0x0005). It sends RR(P=1, ReqSeq = 0) at the end of the move operation over the AMP link.

ALT2:

The IUT's BD_ADDR is smaller than the Lower Tester's BD_ADDR so the IUT sends L2CAP_MOVE_CHANNEL_RSP with result code of "Move Pending" (0x0001). It responds to the RR(P=1) from the Lower Tester with RR(F=1) over the AMP link.

L2CAP/MCH/BV-15-C [Move Channel Request for BR/EDR to AMP (STM Source) – Success]

- Test Purpose

Verify that the IUT can request the move of an L2CAP Streaming Mode channel where the IUT is the data source from a BR/EDR link to an AMP link. If the operation is successful, the channel is in state OPEN over the AMP link.

- Reference

[1] 4.16, 4.17, 4.18, 9.2

- Initial Condition

- An L2CAP Streaming Mode channel exists where the IUT is the data source between the IUT and the Lower Tester in OPEN state.
- The AMP Physical Link exists.
- I(out) outgoing I-frames and I(in) incoming I-frames have been sent and received by the IUT over the channel after it was opened and before the test is executed.

- Test Procedure

Figure 4.142 assumes I(out) and I(in) are 0. The actual values of N(S) and N(R) for both incoming and outgoing traffic must take the number of previously sent and received I-frames into account.

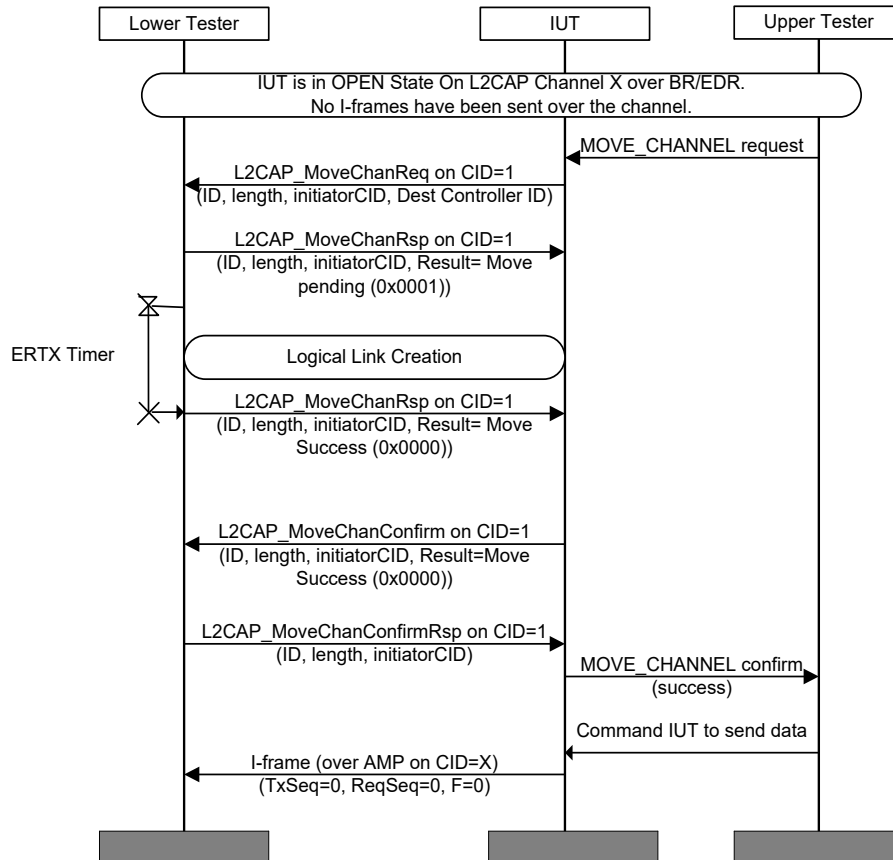

Figure 4.142: L2CAP/MCH/BV-15-C [Move Channel Request for BR/EDR to AMP (STM Source) – Success] MSC

- Test Condition

The Lower Tester responds with result= Move Pending and create the new AMP logical link so the channel can be move from BR/EDR to AMP.

- Expected Outcome

Pass verdict

The IUT transmits an L2CAP_MOVE_CHANNEL_CONFIRMATION_REQ with a result code of “Move Success” (0x0000). After receiving the L2CAP_MOVE_CHANNEL_CONFIRMATION_RSP from the Lower Tester, it sends an I-frame.

L2CAP/MCH/BV-16-C [Move Channel Request for BR/EDR to AMP (STM Sink) – Success]

- Test Purpose

Verify that the IUT can request the move of an L2CAP Streaming Mode channel where the IUT is the data sink from a BR/EDR link to an AMP link. If the operation is successful, the channel is in state OPEN over the AMP link.

- Reference

[1] 4.16, 4.17, 4.18, 9.2

- Initial Condition

- An L2CAP Streaming Mode channel exists where the IUT is the data sink between the IUT and the Lower Tester in OPEN state.
- The AMP Physical Link exists.
- I(out) outgoing I-frames and I(in) incoming I-frames have been sent and received by the IUT over the channel after it was opened and before the test is executed.

- Test Procedure

Figure 4.143 assumes I(out) and I(in) are 0. The actual values of N(S) and N(R) for both incoming and outgoing traffic must take the number of previously sent and received I-frames into account.

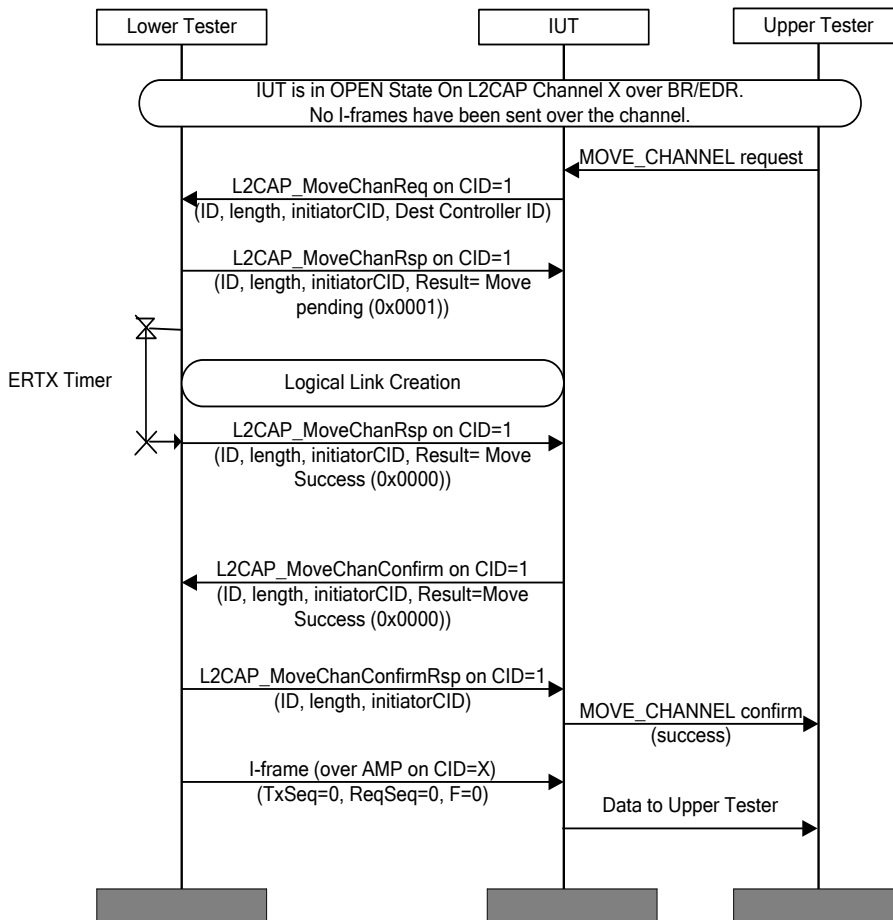

Figure 4.143: L2CAP/MCH/BV-16-C [Move Channel Request for BR/EDR to AMP (STM Sink) – Success] MSC

- Expected Outcome

Pass verdict

The IUT transmits an L2CAP_MOVE_CHANNEL_CONFIRMATION_REQ with a result code of “Move Success” (0x0000). IUT receives an I-frame on the AMP and passes data up to the Upper Tester.

L2CAP/MCH/BV-17-C [Move Channel Request for BR/EDR to AMP (STM Source) – Refused]

• Test Purpose

Verify that the IUT can request the move of an L2CAP Streaming Mode channel where the IUT is the data source from a BR/EDR link to an AMP link, and recover if the Lower Tester refuses the move. In this case the channel remains in state OPEN over the BR/EDR link.

• Reference

[1] 4.16, 4.17, 4.18, 9.2

• Initial Condition

- An L2CAP Streaming Mode channel exists where the IUT is the data source between the IUT and the Lower Tester in OPEN state.
- The AMP Physical Link exists.
- I(out) outgoing I-frames and I(in) incoming I-frames have been sent and received by the IUT over the channel after it was opened and before the test is executed.

• Test Procedure

Figure 4.144 assumes I(out) and I(in) are 0. The actual values of N(S) and N(R) for both incoming and outgoing traffic must take the number of previously sent and received I-frames into account.

The channel move is not successful. The IUT and the Lower Tester return to the BR/EDR link after the unsuccessful move attempt.

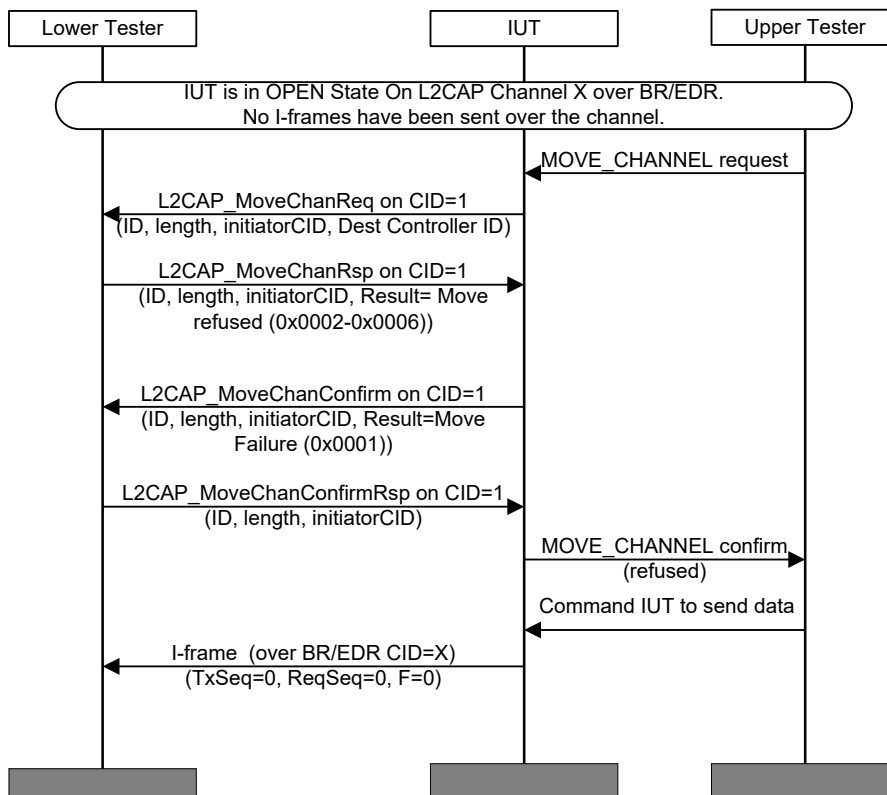

Figure 4.144: L2CAP/MCH/BV-17-C [Move Channel Request for BR/EDR to AMP (STM Source) – Refused] MSC

- Expected Outcome

Pass verdict

The IUT transmits an L2CAP_MOVE_CHANNEL_CONFIRMATION_REQ packet with a result code of “Move failure – one or both sides refuse” (0x0001) and it sends an I-frame over the BR/EDR link on the same CID as before the move attempt.

L2CAP/MCH/BV-18-C [Move Channel Request for BR/EDR to AMP (STM Sink) – Refused]

- Test Purpose

Verify that the IUT can request the move of an L2CAP Streaming Mode channel where the IUT is the data sink from a BR/EDR link to an AMP link, and recover if the Lower Tester refuses the move. In this case the channel remains in state OPEN over the BR link.

- Reference

[1] 4.16, 4.17, 4.18, 9.2

- Initial Condition

- An L2CAP Streaming Mode channel exists where the IUT is the data sink between the IUT and the Lower Tester in OPEN state.
- The AMP Physical Link exists.
- I(out) outgoing I-frames and I(in) incoming I-frames have been sent and received by the IUT over the channel after it was opened and before the test is executed.

- Test Procedure

Figure 4.145 assumes I(out) and I(in) are 0. The actual values of N(S) and N(R) for both incoming and outgoing traffic must take the number of previously sent and received I-frames into account.

The channel move is not successful. The IUT and the Lower Tester return to the BR/EDR link after the unsuccessful move attempt.

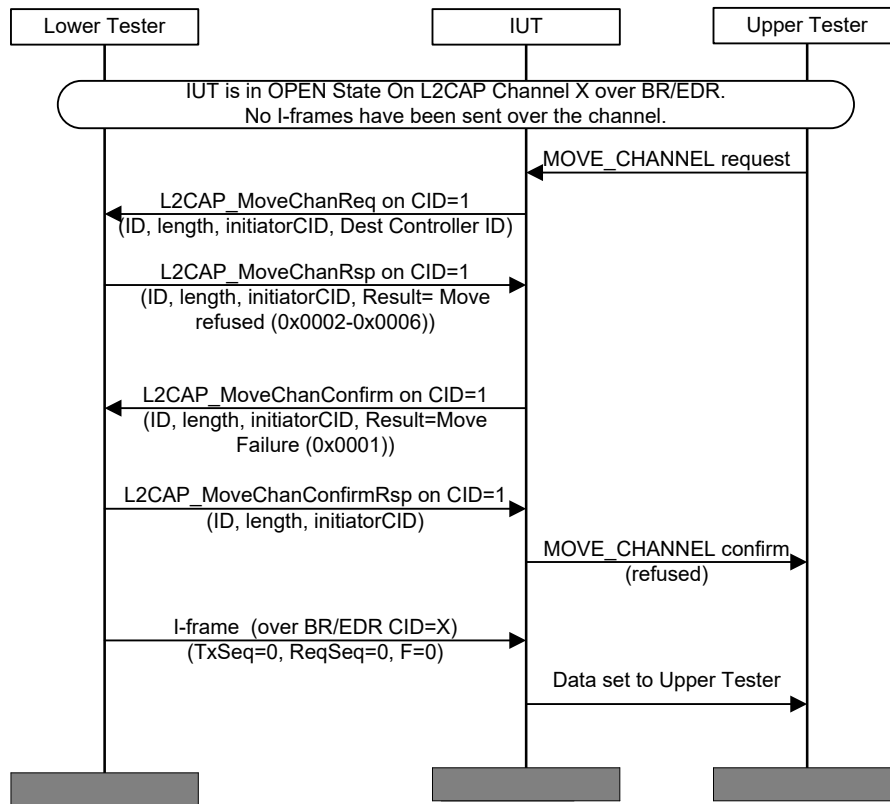

Figure 4.145: L2CAP/MCH/BV-18-C [Move Channel Request for BR/EDR to AMP (STM Sink) – Refused] MSC

- Expected Outcome

Pass verdict

The IUT transmits an L2CAP_MOVE_CHANNEL_CONFIRMATION_REQ packet with a result code of Failure (0x0001) and it passes received data to the Upper Tester.

L2CAP/MCH/BV-19-C [Move Channel Request for BR/EDR to AMP (STM Source) – AMP Fail]

- Test Purpose

Verify that the IUT can request the move of an L2CAP Streaming Mode channel where the IUT is the data source from a BR/EDR link to an AMP link, and recover if the AMP logical link creation fails. In this case the channel remains in state OPEN over the BR link.

- Reference

[1] 4.16, 4.17, 4.18, 9.2

- Initial Condition

- An L2CAP Streaming Mode channel exists where the IUT is the data source between the IUT and the Lower Tester in OPEN state.
- The AMP Physical Link exists.
- I(out) outgoing I-frames and I(in) incoming I-frames have been sent and received by the IUT over the channel after it was opened and before the test is executed.

- Test Procedure

Figure 4.146 assumes I(out) and I(in) are 0. The actual values of N(S) and N(R) for both incoming and outgoing traffic must take the number of previously sent and received I-frames into account.

The channel move is not successful. The IUT and the Lower Tester return to the BR/EDR link after the unsuccessful move attempt.

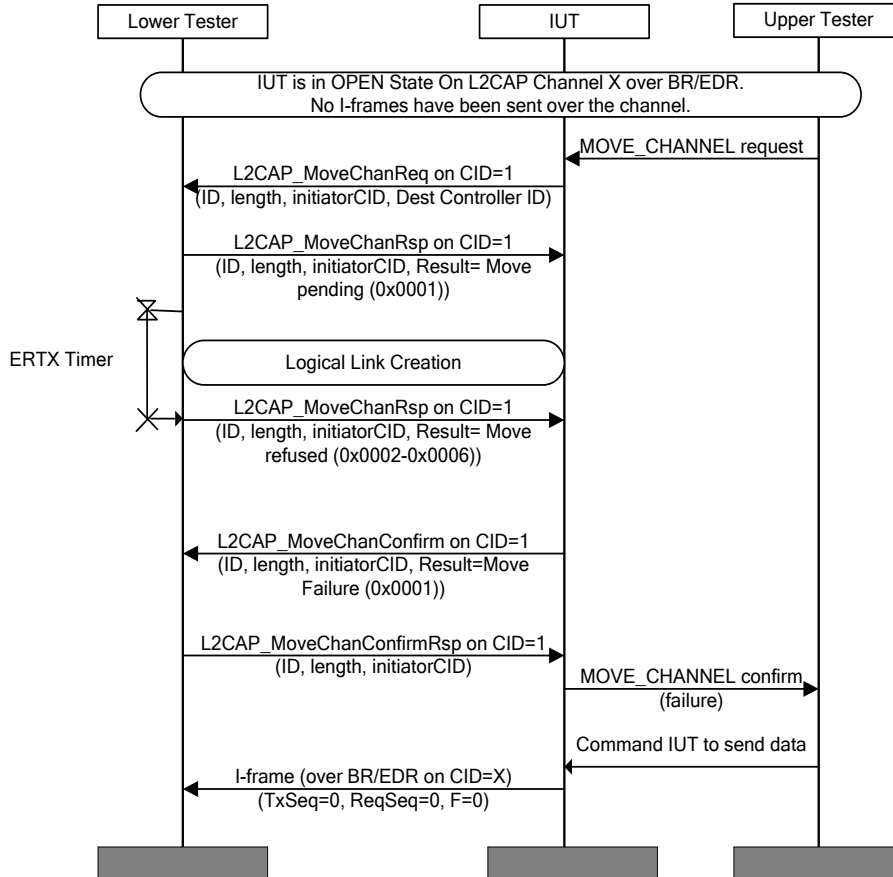

Figure 4.146: L2CAP/MCH/BV-19-C [Move Channel Request for BR/EDR to AMP (STM Source) – AMP Fail] MSC

- Expected Outcome

Pass verdict

The IUT transmits an L2CAP_MOVE_CHANNEL_CONFIRMATION_REQ packet with a result code of “Move Failure – one or both sides refuse” (0x0001) and sends an I-frame over the BR/EDR link on the same CID as before the move attempt.

L2CAP/MCH/BV-20-C [Move Channel Request for BR/EDR to AMP (STM Sink) – AMP Failed]

- Test Purpose

Verify that the IUT can request the move of an L2CAP Streaming Mode channel where the IUT is the data sink from a BR/EDR link to an AMP link, and recover if the AMP Logical Link creation fails. In this case the channel remains in state OPEN over the BR link.

- Reference

[1] 4.16, 4.17, 4.18, 9.2



- Initial Condition
 - An L2CAP Streaming Mode channel exists where the IUT is the data sink between the IUT and the Lower Tester in OPEN state.
 - The AMP Physical Link exists.
 - I(out) outgoing I-frames and I(in) incoming I-frames have been sent and received by the IUT over the channel after it was opened and before the test is executed.
- Test Procedure

Figure 4.147 assumes I(out) and I(in) are 0. The actual values of N(S) and N(R) for both incoming and outgoing traffic must take the number of previously sent and received I-frames into account.

The channel move is not successful. The IUT and the Lower Tester return to the BR/EDR channel after the unsuccessful move attempt.

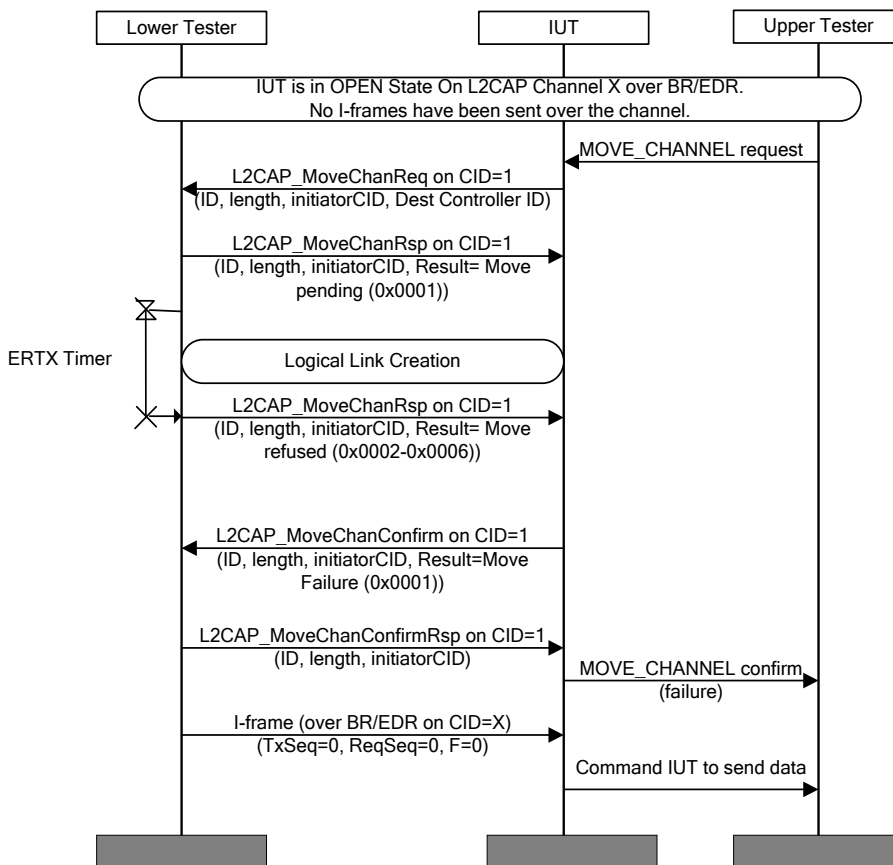

Figure 4.147: L2CAP/MCH/BV-20-C [Move Channel Request for BR/EDR to AMP (STM Sink) – AMP Failed] MSC

- Expected Outcome

Pass verdict

The IUT transmits an L2CAP_MOVE_CHANNEL_CONFIRMATION_REQ packet with a result code of “Move Failure – one or both sides refuse” (0x0001) and passes the received data to the Upper Tester.

L2CAP/MCH/BV-21-C [Move Channel Request for AMP to BR/EDR (STM Source) – Success]

• Test Purpose

Verify that the IUT can request the move of an L2CAP Streaming Mode channel where the IUT is the data source from a BR/EDR link to an AMP link. If the operation is successful, the channel is in state OPEN over the AMP link.

• Reference

[1] 4.16, 4.17, 4.18, 9.2

• Initial Condition

- An L2CAP Streaming Mode channel exists where the IUT is the data source between the IUT and the Lower Tester in OPEN state.
- The AMP Physical Link exists with a guaranteed logical link. The requirements for that AMP channel does not exceed the capabilities of EDR.
- I(out) outgoing I-frames and I(in) incoming I-frames have been sent and received by the IUT over the channel after it was opened and before the test is executed.

• Test Procedure

Figure 4.148 assumes I(out) and I(in) are 0. The actual values of N(S) and N(R) for both incoming and outgoing traffic must take the number of previously sent and received I-frames into account.

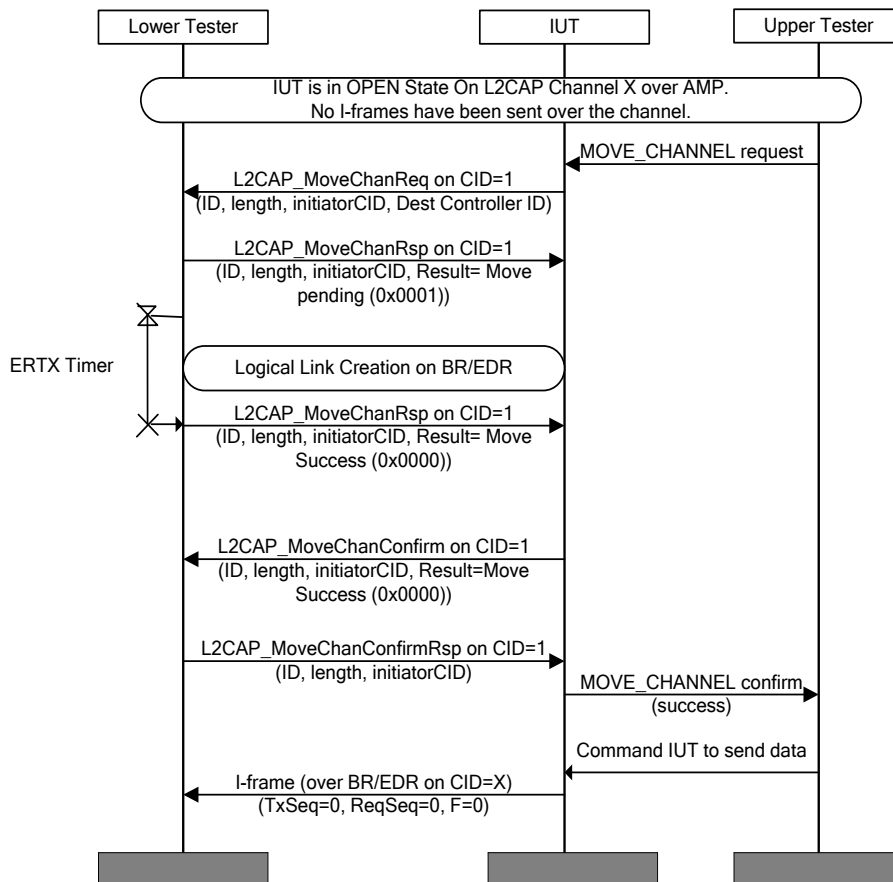

Figure 4.148: L2CAP/MCH/BV-21-C [Move Channel Request for AMP to BR/EDR (STM Source) – Success] MSC

- Expected Outcome

Pass verdict

The IUT transmits an L2CAP_MOVE_CHANNEL_CONFIRMATION_REQ with a result code of “Move Success” (0x0000). After receiving the L2CAP_MOVE_CHANNEL_CONFIRMATION_RSP from the Lower Tester, it sends an I-frame over BR/EDR.

L2CAP/MCH/BV-22-C [Move Channel Request for AMP to BR/EDR (STM Sink) – Success]

- Test Purpose

Verify that the IUT can request the move of an L2CAP Streaming Mode channel where the IUT is the data sink from an AMP link to a BR/EDR link. If the operation is successful, the channel is in state OPEN over the BR/EDR link.

- Reference

[1] 4.16, 4.17, 4.18, 9.2

- Initial Condition

- An L2CAP Streaming Mode channel exists where the IUT is the data sink between the IUT and the Lower Tester in OPEN state.
- The BR/EDR Physical Link exists.
- I(out) outgoing I-frames and I(in) incoming I-frames have been sent and received by the IUT over the channel after it was opened and before the test is executed.

- Test Procedure

Figure 4.149 assumes I(out) and I(in) are 0. The actual values of N(S) and N(R) for both incoming and outgoing traffic must take the number of previously sent and received I-frames into account.

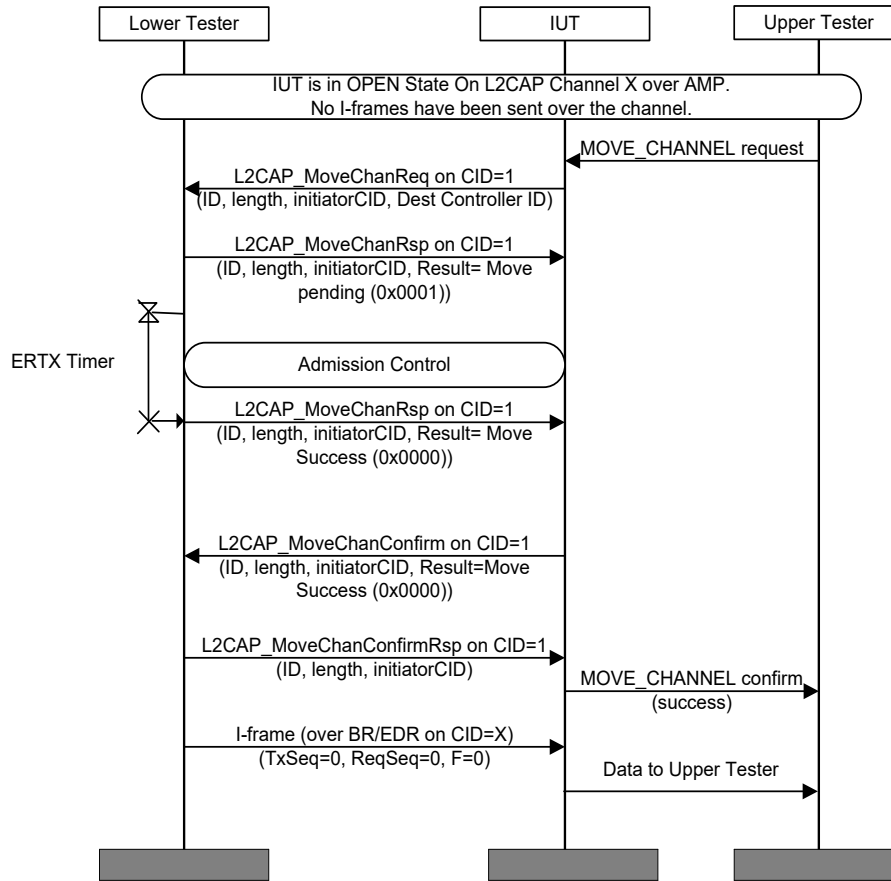

Figure 4.149: L2CAP/MCH/BV-22-C [Move Channel Request for AMP to BR/EDR (STM Sink) – Success] MSC

- Expected Outcome

Pass verdict

The IUT transmits an L2CAP_MOVE_CHANNEL_CONFIRMATION_REQ with a result code of “Move Success” (0x0000). IUT receives I-frame on BR/EDR and passes data up to the Upper Tester.

L2CAP/MCH/BV-23-C [Move Channel Request for AMP to BR/EDR (STM Source) – Refused]

- Test Purpose

Verify that the IUT can request the move of an L2CAP Streaming Mode channel where the IUT is the data source from an AMP link to a BR/EDR link, and recover if the Lower Tester refuses the move. In this case the channel remains in state OPEN over the AMP link.

- Reference

[1] 4.16, 4.17, 4.18, 9.2

- Initial Condition
 - An L2CAP Streaming Mode channel exists where the IUT is the data source between the IUT and the Lower Tester in OPEN state.
 - The BR/EDR Physical Link exists.
 - I(out) outgoing I-frames and I(in) incoming I-frames have been sent and received by the IUT over the channel after it was opened and before the test is executed.
- Test Procedure

Figure 4.150 assumes I(out) and I(in) are 0. The actual values of N(S) and N(R) for both incoming and outgoing traffic must take the number of previously sent and received I-frames into account.

The channel move is not successful. The IUT and the Lower Tester return to the AMP link after the unsuccessful move attempt.

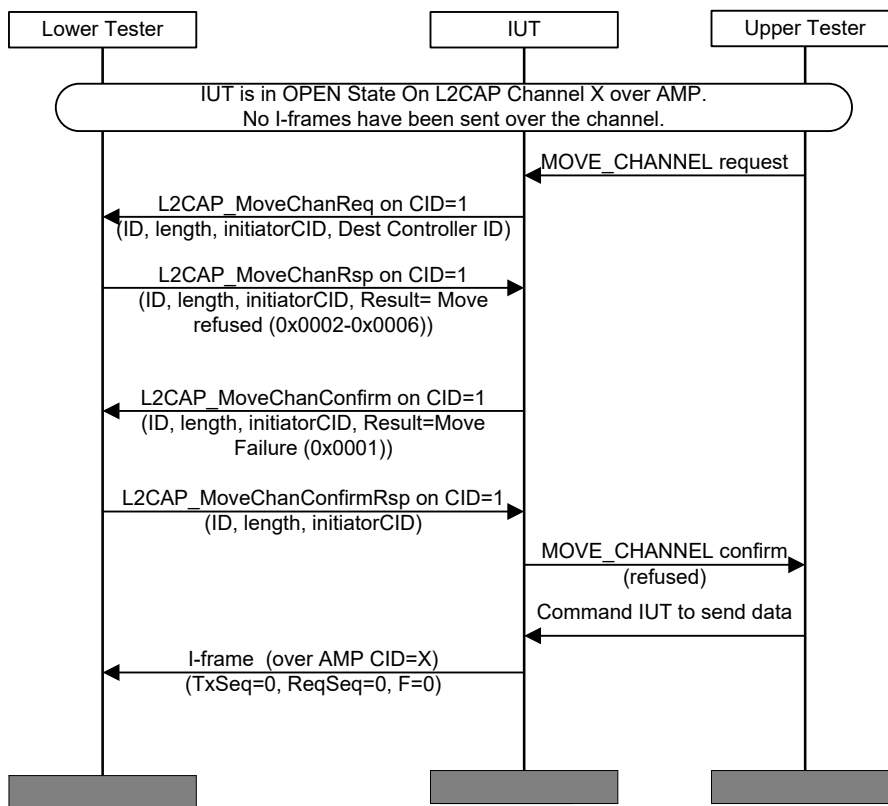

Figure 4.150: L2CAP/MCH/BV-23-C [Move Channel Request for AMP to BR/EDR (STM Source) – Refused] MSC

- Expected Outcome

Pass verdict

The IUT transmits an L2CAP_MOVE_CHANNEL_CONFIRMATION_REQ packet with a result code of “Move failure – one or both sides refuse” (0x0001) and it sends an I-frame over the AMP link on the same CID as before the move attempt.

L2CAP/MCH/BV-24-C [Move Channel Request for AMP to BR/EDR (STM Sink) – Refused]

• Test Purpose

Verify that the IUT can request the move of an L2CAP Streaming Mode channel where the IUT is the data sink from an AMP link to a BR/EDR link, and recover if the Lower Tester refuses the move. In this case the channel remains in state OPEN over the AMP link.

• Reference

[1] 4.16, 4.17, 4.18, 9.2

• Initial Condition

- An L2CAP Streaming Mode channel exists where the IUT is the data sink between the IUT and the Lower Tester in OPEN state.
- The BR/EDR Physical Link exists.
- I(out) outgoing I-frames and I(in) incoming I-frames have been sent and received by the IUT over the channel after it was opened and before the test is executed.

• Test Procedure

Figure 4.151 assumes I(out) and I(in) are 0. The actual values of N(S) and N(R) for both incoming and outgoing traffic must take the number of previously sent and received I-frames into account.

The channel move is not successful. The IUT and the Lower Tester return to the AMP channel after the unsuccessful move attempt.

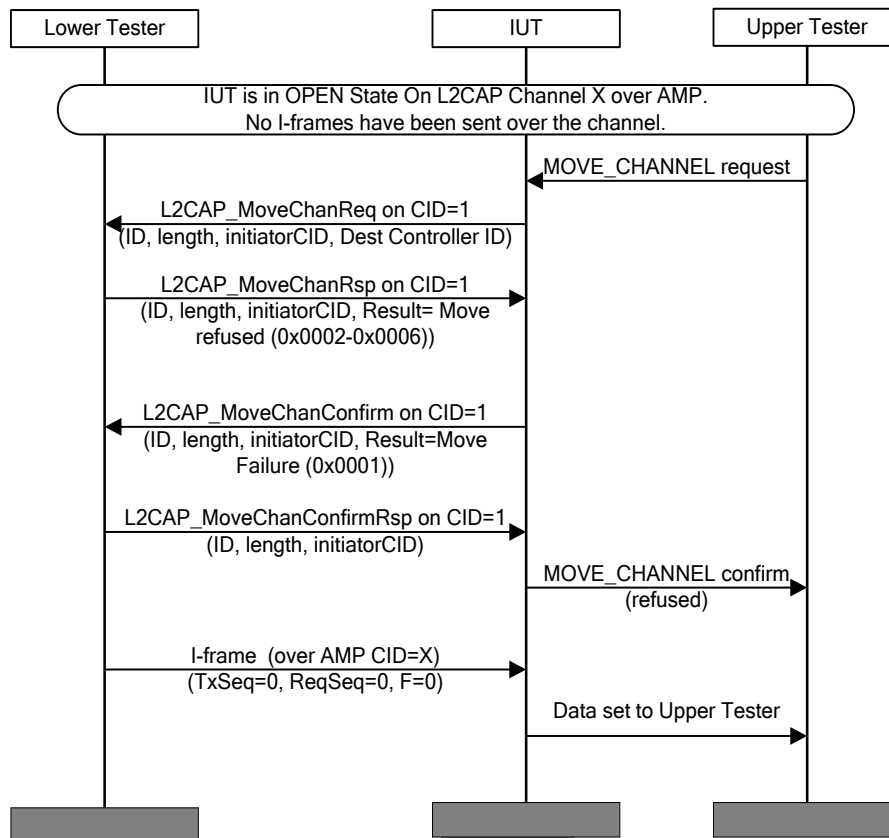

Figure 4.151: L2CAP/MCH/BV-24-C [Move Channel Request for AMP to BR/EDR (STM Sink) – Refused] MSC

- Expected Outcome

Pass verdict

The IUT transmits an L2CAP_MOVE_CHANNEL_CONFIRMATION_REQ packet with a result code of “Move Failure – one or both side refuse” (0x0001) and it passes received data to the Upper Tester.

L2CAP/MCH/BV-25-C [Move Channel Request for AMP to BR/EDR (STM Source) – AMP Fail]

- Test Purpose

Verify that the IUT can request the move of an L2CAP Streaming Mode channel where the IUT is the data source from an AMP link to a BR/EDR link, and recover if the admission control fails. In this case the channel remains in state OPEN over the AMP link.

- Reference

[1] 4.16, 4.17, 4.18, 9.2

- Initial Condition

- An L2CAP Streaming Mode channel exists where the IUT is the data source between the IUT and the Lower Tester in OPEN state.
- The BR/EDR Physical Link exists.
- I(out) outgoing I-frames and I(in) incoming I-frames have been sent and received by the IUT over the channel after it was opened and before the test is executed.

- Test Procedure

Figure 4.152 assumes I(out) and I(in) are 0. The actual values of N(S) and N(R) for both incoming and outgoing traffic must take the number of previously sent and received I-frames into account.

The channel move is not successful. The IUT and the Lower Tester return to the AMP link after the unsuccessful move attempt.

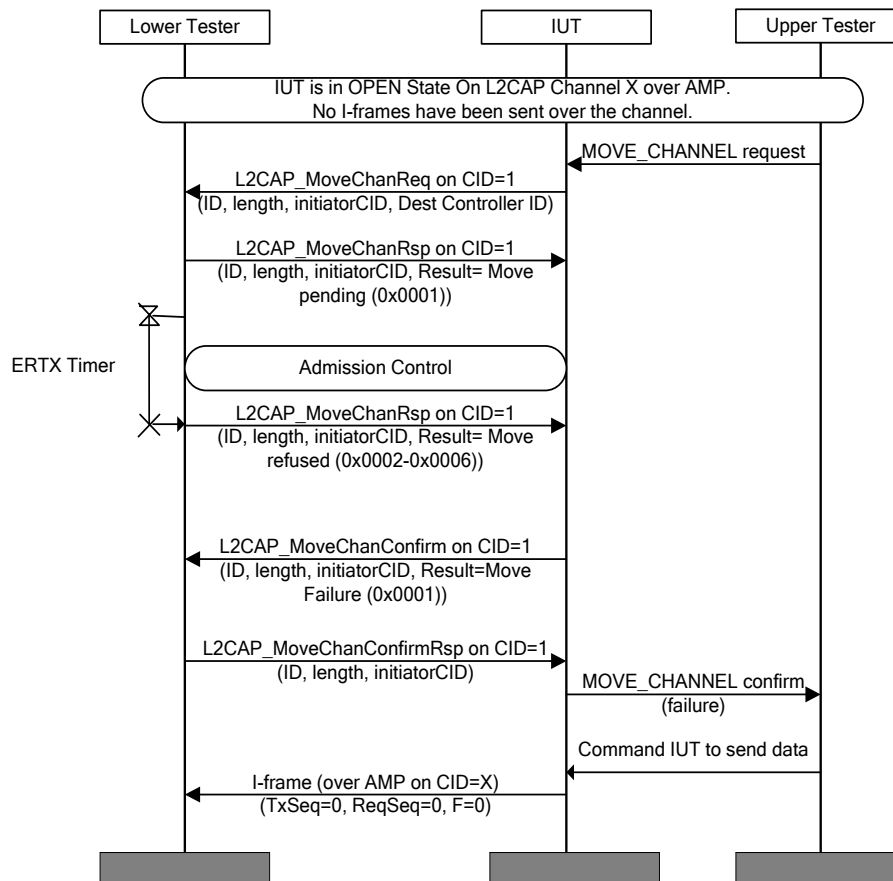

Figure 4.152: L2CAP/MCH/BV-25-C [Move Channel Request for AMP to BR/EDR (STM Source) – AMP Fail] MSC

- Expected Outcome

Pass verdict

The IUT transmits an L2CAP_MOVE_CHANNEL_CONFIRMATION_REQ packet with a result code of “Move failure – one or both sides refuse” (0x0001) and sends an I-frame over the AMP link on the same CID as before the move attempt.

L2CAP/MCH/BV-26-C [Move Channel Request for AMP to BR/EDR (STM Sink) – AMP Failed]

- Test Purpose

Verify that the IUT can request the move of an L2CAP Streaming Mode channel where the IUT is the data sink from an AMP link to a BR/EDR link, and recover if the Admission Control fails. In this case the channel remains in state OPEN over the AMP link.

- Reference

[1] 4.16, 4.17, 4.18, 9.2

- Initial Condition

- An L2CAP Streaming Mode channel exists where the IUT is the data sink between the IUT and the Lower Tester in OPEN state.
- The BR/EDR Physical Link exists.



- I(out) outgoing I-frames and I(in) incoming I-frames have been sent and received by the IUT over the channel after it was opened and before the test is executed.

- Test Procedure

Figure 4.153 assumes I(out) and I(in) are 0. The actual values of N(S) and N(R) for both incoming and outgoing traffic must take the number of previously sent and received I-frames into account.

The channel move is not successful. The IUT and the Lower Tester return to the AMP link after the unsuccessful move attempt.

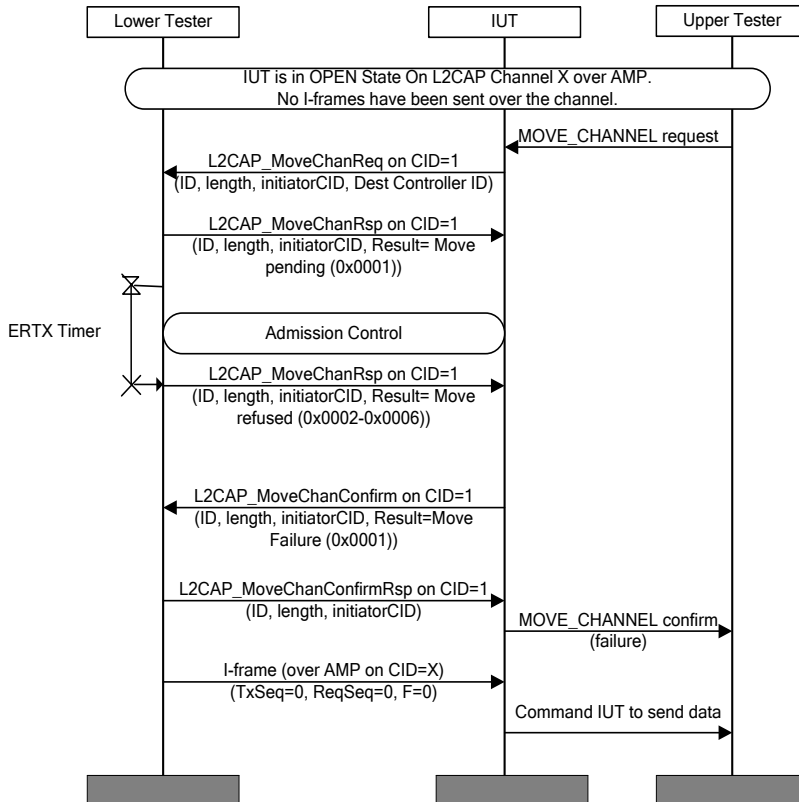

Figure 4.153: L2CAP/MCH/BV-26-C [Move Channel Request for AMP to BR/EDR (STM Sink) – AMP Failed] MSC

- Expected Outcome

Pass verdict

The IUT transmits an L2CAP_MOVE_CHANNEL_CONFIRMATION_REQ packet with a result code of “Move failure – one or both sides refuse” (0x0001) and passes the received data to the Upper Tester.

L2CAP/MCH/BV-27-C [Move Channel Response for BR/EDR to AMP (STM Source) – Success]

- Test Purpose

Verify that the IUT can respond to a move request of an L2CAP Streaming Mode channel where the IUT is the data source from a BR/EDR link to an AMP link. If the operation is successful, the channel is in state OPEN over the AMP link.

- Reference
 - [1] 4.16, 4.17, 4.18, 9.2
- Initial Condition
 - An L2CAP Streaming Mode channel exists where the IUT is the data source between the IUT and the Lower Tester in OPEN state.
 - The AMP Physical Link exists.
 - I(out) outgoing I-frames and I(in) incoming I-frames have been sent and received by the IUT over the channel after it was opened and before the test is executed.
- Test Procedure

Figure 4.154 assumes I(out) and I(in) are 0. The actual values of N(S) and N(R) for both incoming and outgoing traffic must take the number of previously sent and received I-frames into account.

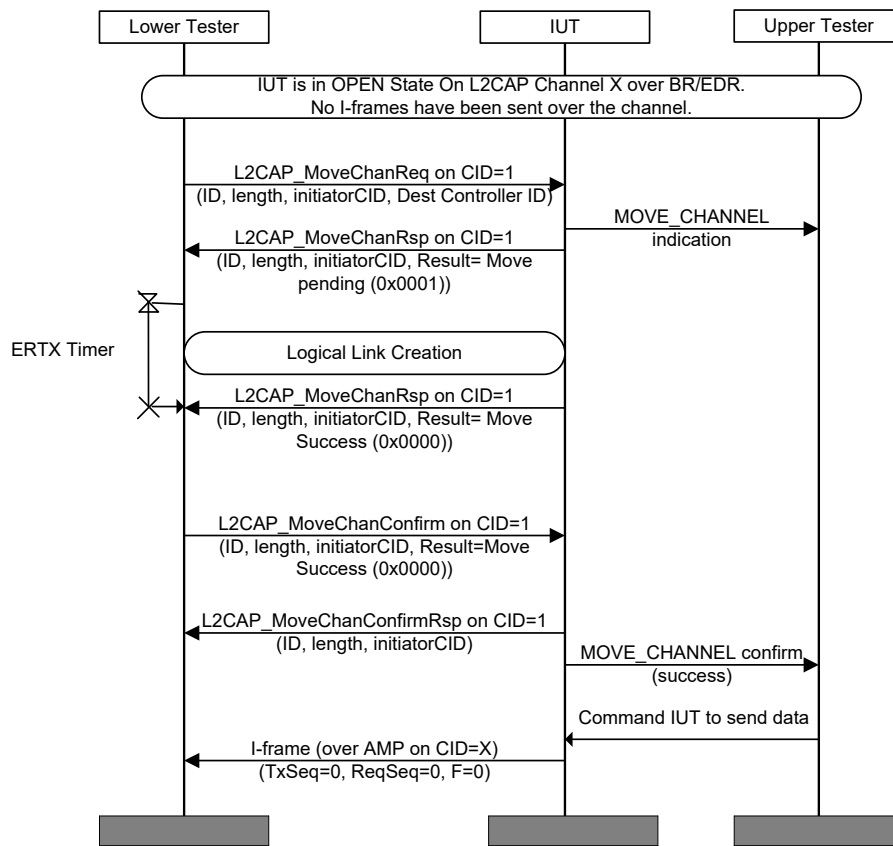

Figure 4.154: L2CAP/MCH/BV-27-C [Move Channel Response for BR/EDR to AMP (STM Source) – Success] MSC

- Expected Outcome

Pass verdict

The channel is moved successfully and the IUT sends an I-frame over the AMP link after the move completes.

L2CAP/MCH/BV-28-C [Move Channel Response for BR/EDR to AMP (STM Sink) – Success]

• Test Purpose

Verify that the IUT can respond to a move request of an L2CAP Streaming Mode channel where the IUT is the data sink from a BR/EDR link to an AMP link. If the operation is successful, the channel is in state OPEN over the AMP link.

• Reference

[1] 4.16, 4.17, 4.18, 9.2

• Initial Condition

- An L2CAP Streaming Mode channel exists where the IUT is the data sink between the IUT and the Lower Tester in OPEN state.
- The AMP Physical Link exists.
- I(out) outgoing I-frames and I(in) incoming I-frames have been sent and received by the IUT over the channel after it was opened and before the test is executed.

• Test Procedure

Figure 4.155 assumes I(out) and I(in) are 0. The actual values of N(S) and N(R) for both incoming and outgoing traffic must take the number of previously sent and received I-frames into account.

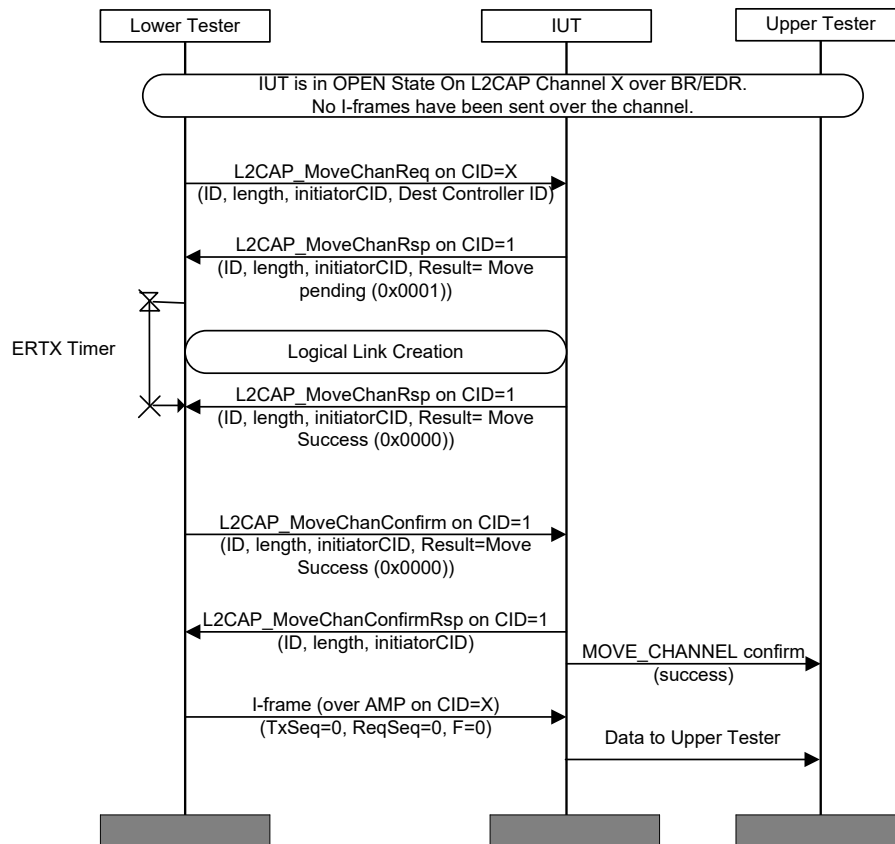

Figure 4.155: L2CAP/MCH/BV-28-C [Move Channel Response for BR/EDR to AMP (STM Sink) – Success] MSC

- Expected Outcome

Pass verdict

The channel is successfully moved from the BR/EDR link to the AMP link and the received data is passed to the Upper Tester.

L2CAP/MCH/BV-29-C [Move Channel Response for AMP to BR/EDR (STM Source) – Success]

- Test Purpose

Verify that the IUT can respond to a move request of an L2CAP Streaming Mode channel where the IUT is the data source. The channel is moved from an AMP to a BR/EDR link. If the operation is successful, the channel is in state OPEN over the BR/EDR link.

- Reference

[1] 4.16, 4.17, 4.18, 9.2

- Initial Condition

- An L2CAP Streaming Mode channel exists where the IUT is the data source between the IUT and the Lower Tester in OPEN state.
- The BR/EDR Physical Link exists.
- I(out) outgoing I-frames and I(in) incoming I-frames have been sent and received by the IUT over the channel after it was opened and before the test is executed.

- Test Procedure

Figure 4.156 assumes I(out) and I(in) are 0. The actual values of N(S) and N(R) for both incoming and outgoing traffic must take the number of previously sent and received I-frames into account.

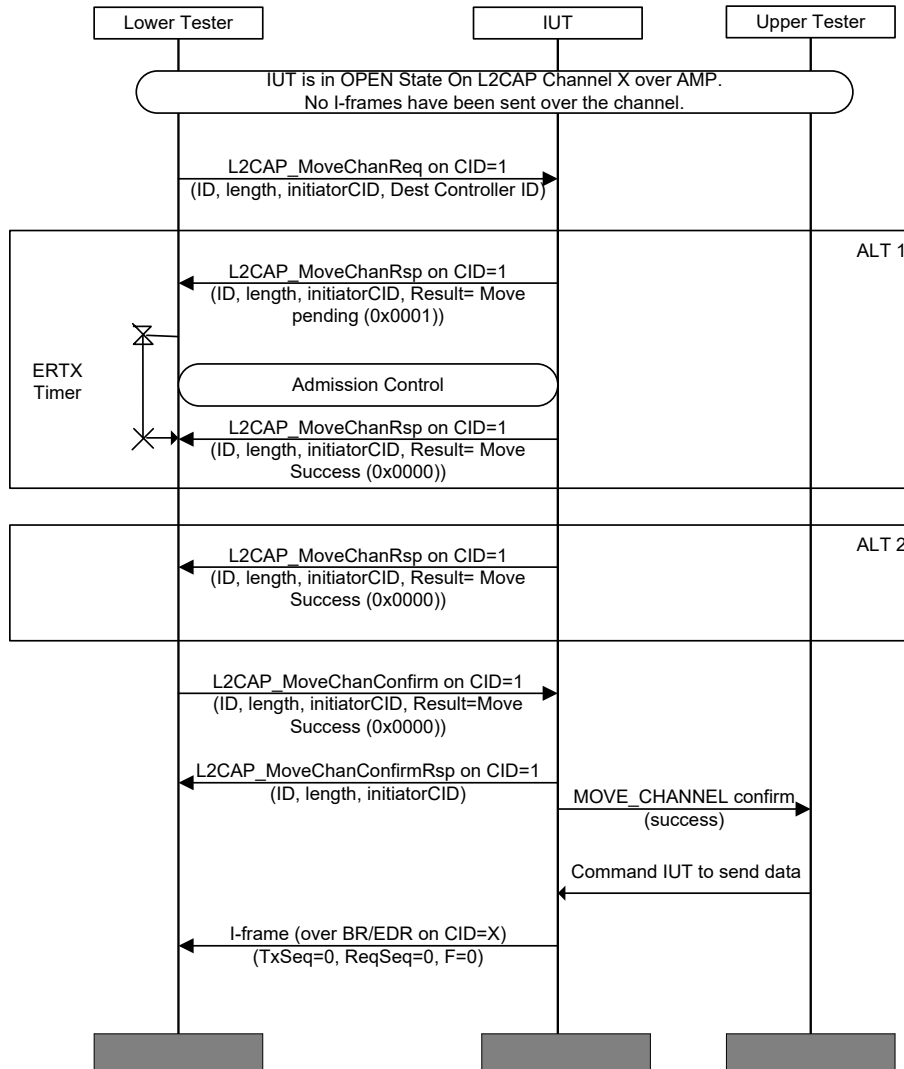

Figure 4.156: L2CAP/MCH/BV-29-C [Move Channel Response for AMP to BR/EDR (STM Source) – Success] MSC

- Test Condition

The channel's Extended Flow Specification is valid for a BR/EDR link.

- Expected Outcome

Pass verdict

The channel is moved successfully and the IUT sends an I-frame over the BR/EDR link after the move completes.

L2CAP/MCH/BV-30-C [Move Channel Response for AMP to BR/EDR (STM Sink) – Success]

• Test Purpose

Verify that the IUT can respond to a move request for an L2CAP Streaming Mode channel where the IUT is the data sink. The channel is moved from an AMP link to a BR/EDR link. If the operation is successful, the channel is in state OPEN over the BR/EDR link.

• Reference

[1] 4.16, 4.17, 4.18, 9.2

• Initial Condition

- An L2CAP Streaming Mode channel exists where the IUT is the data sink between the IUT and the Lower Tester in OPEN state.
- The BR/EDR Physical Link exists.
- I(out) outgoing I-frames and I(in) incoming I-frames have been sent and received by the IUT over the channel after it was opened and before the test is executed.

• Test Procedure

Figure 4.157 assumes I(out) and I(in) are 0. The actual values of N(S) and N(R) for both incoming and outgoing traffic must take the number of previously sent and received I-frames into account.

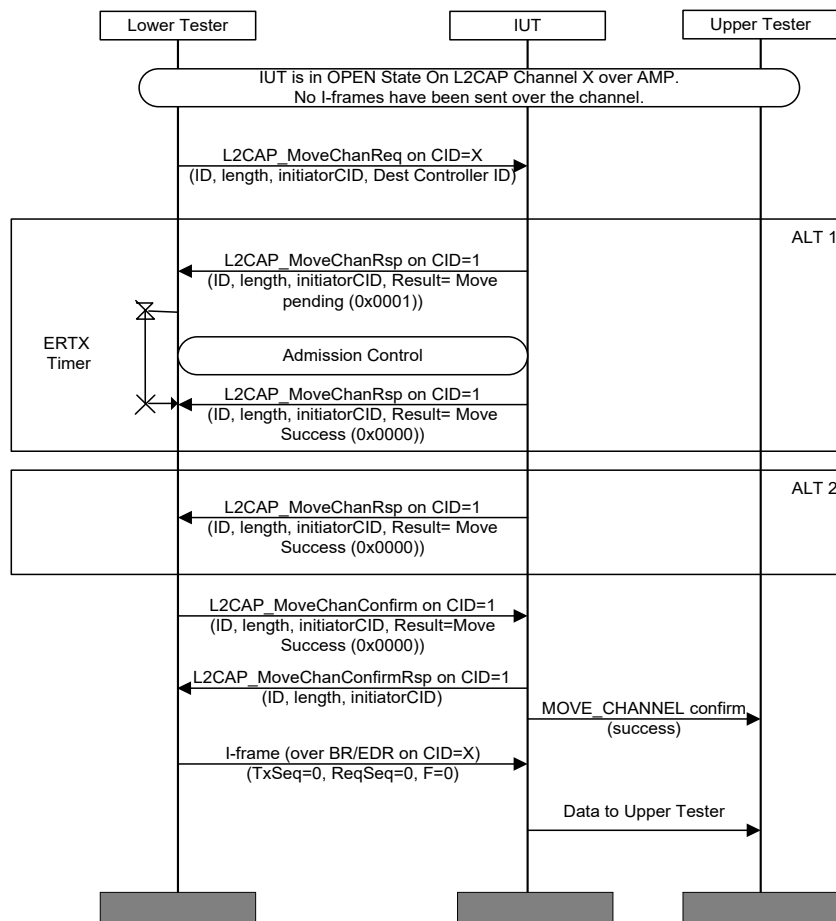

Figure 4.157: L2CAP/MCH/BV-30-C [Move Channel Response for AMP to BR/EDR (STM Sink) – Success] MSC

- Test Condition

The channel's Extended Flow Specification is valid for a BR/EDR link.

- Expected Outcome

Pass verdict

The channel is successfully moved from the AMP link to the BR/EDR link and the received data is passed to the Upper Tester.

L2CAP/MCH/BV-31-C [Move Channel Response for BR/EDR to AMP (STM Source) – Failed]

- Test Purpose

Verify that the IUT can respond to a move request of an L2CAP Streaming Mode channel where the IUT is the data source and is able to recover when the move operation fails. The channel is to be moved from a BR/EDR link to an AMP link but move operation fails.

- Reference

[1] 4.16, 4.17, 4.18, 9.2

- Initial Condition

- An L2CAP Streaming Mode channel exists where the IUT is the data source between the IUT and the Lower Tester in OPEN state.
- The AMP Physical Link exists.
- I(out) outgoing I-frames and I(in) incoming I-frames have been sent and received by the IUT over the channel after it was opened and before the test is executed.

- Test Procedure

Figure 4.158 assumes I(out) and I(in) are 0. The actual values of N(S) and N(R) for both incoming and outgoing traffic must take the number of previously sent and received I-frames into account.

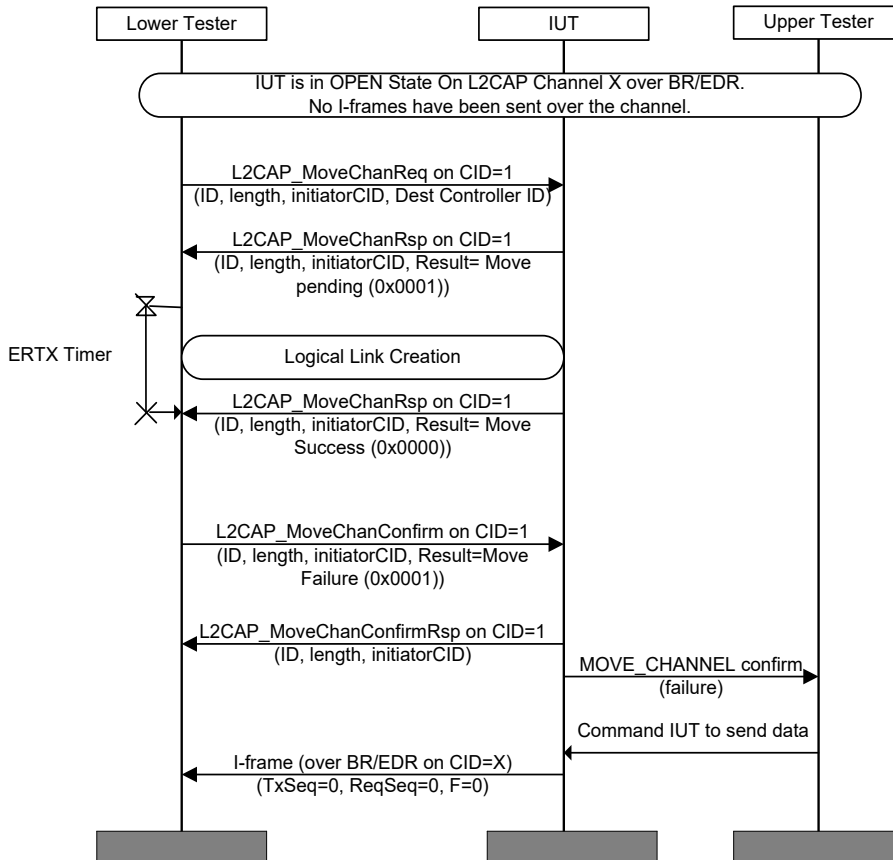

Figure 4.158: L2CAP/MCH/BV-31-C [Move Channel Response for BR/EDR to AMP (STM Source) – Failed] MSC

- Expected Outcome

Pass verdict

The IUT sends an I-frame over the BR/EDR link after the failed move operation completes.

L2CAP/MCH/BV-32-C [Move Channel Response for BR/EDR to AMP (STM Sink) – Failed]

- Test Purpose

Verify that the IUT can respond to a move request of an L2CAP Streaming Mode channel where the IUT is the data sink and recover when the move operation fails. The channel is to not be moved from a BR/EDR link to an AMP link, but instead remains in the BR/EDR link.

- Reference

[1] 4.16, 4.17, 4.18, 9.2

- Initial Condition

- An L2CAP Streaming Mode channel exists where the IUT is the data sink between the IUT and the Lower Tester in OPEN state.
- The AMP Physical Link exists.

- I(out) outgoing I-frames and I(in) incoming I-frames have been sent and received by the IUT over the channel after it was opened and before the test is executed.

- Test Procedure

Figure 4.159 assumes I(out) and I(in) are 0. The actual values of N(S) and N(R) for both incoming and outgoing traffic must take the number of previously sent and received I-frames into account.

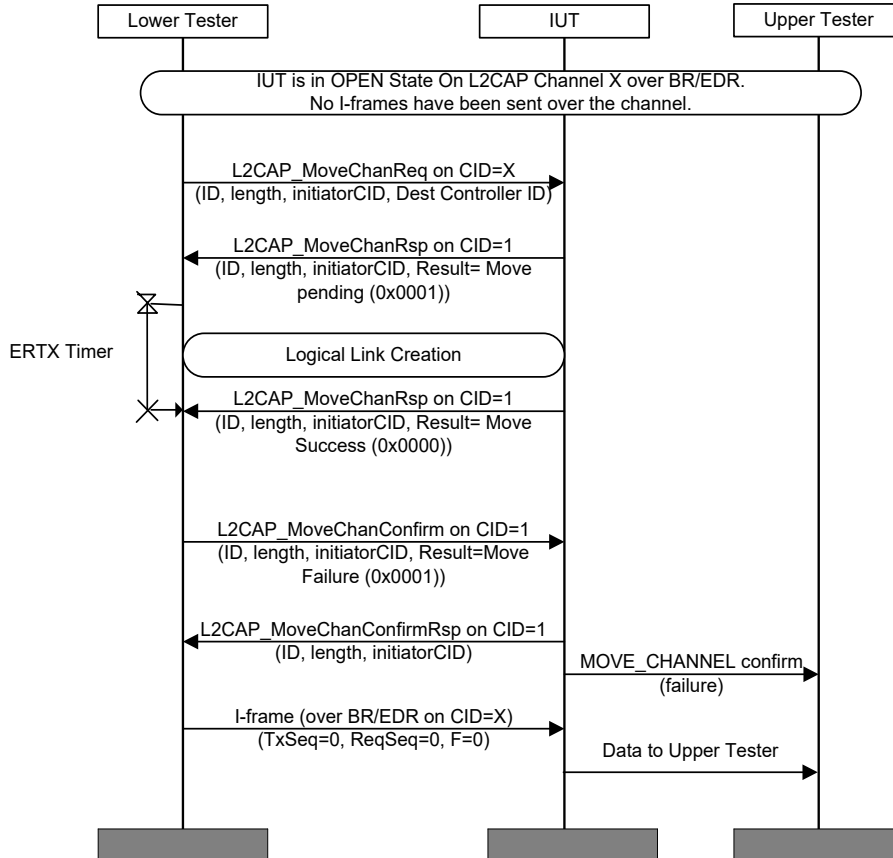

Figure 4.159: L2CAP/MCH/BV-32-C [Move Channel Response for BR/EDR to AMP (STM Sink) – Failed] MSC

- Expected Outcome

Pass verdict

The IUT passed received data to the Upper Tester after the failed move operation completes.

L2CAP/MCH/BV-33-C [Move Channel Response for AMP to BR/EDR (STM Source) – Failed]

- Test Purpose

Verify that the IUT can respond to a move request of an L2CAP Streaming Mode channel where the IUT is the data source and recover when the move operation fails. The channel is not to be moved from an AMP to a BR/EDR link, but instead remains on the AMP.

- Reference

[1] 4.16, 4.17, 4.18, 9.2

- Initial Condition
 - An L2CAP Streaming Mode channel exists where the IUT is the data source between the IUT and the Lower Tester in OPEN state.
 - The BR/EDR Physical Link exists.
 - I(out) outgoing I-frames and I(in) incoming I-frames have been sent and received by the IUT over the channel after it was opened and before the test is executed.
- Test Procedure

Figure 4.160 assumes I(out) and I(in) are 0. The actual values of N(S) and N(R) for both incoming and outgoing traffic must take the number of previously sent and received I-frames into account.

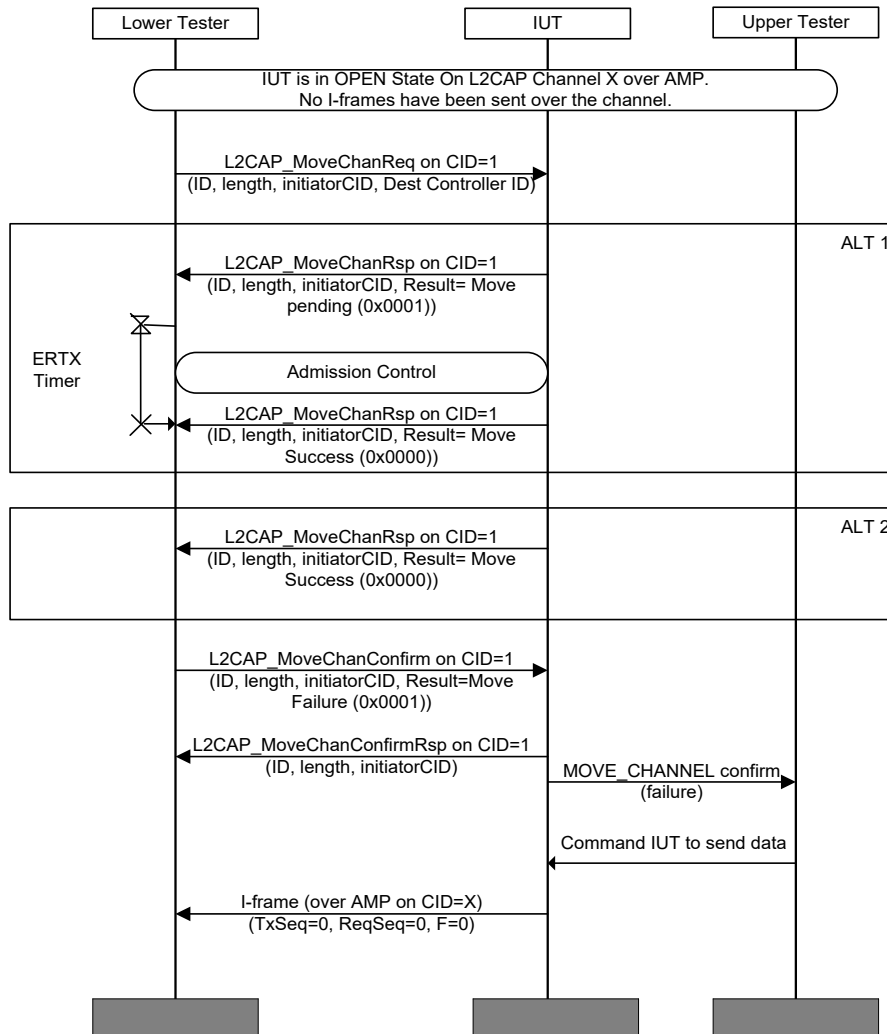

Figure 4.160: L2CAP/MCH/BV-33-C [Move Channel Response for AMP to BR/EDR (STM Source) – Failed] MSC

- Test Condition
 - The channel's Extended Flow Specification is valid for a BR/EDR link.

Expected Outcome

Pass verdict

The IUT sends an I-frame over the AMP link after the failed move operation completes.



L2CAP/MCH/BV-34-C [Move Channel Response for AMP to BR/EDR (STM Sink) – Failed]

• Test Purpose

Verify that the IUT can respond to a move request for an L2CAP Streaming Mode channel where the IUT is the data sink and recover when the move operation fails. The channel is not to be moved from an AMP link to a BR/EDR link, but instead remains on the AMP link.

• Reference

[1] 4.16, 4.17, 4.18, 9.2

• Initial Condition

- An L2CAP Streaming Mode channel exists where the IUT is the data sink between the IUT and the Lower Tester in OPEN state.
- The BR/EDR Physical Link exists.
- I(out) outgoing I-frames and I(in) incoming I-frames have been sent and received by the IUT over the channel after it was opened and before the test is executed.

- Test Procedure

Figure 4.161 assumes I(out) and I(in) are 0. The actual values of N(S) and N(R) for both incoming and outgoing traffic must take the number of previously sent and received I-frames into account.

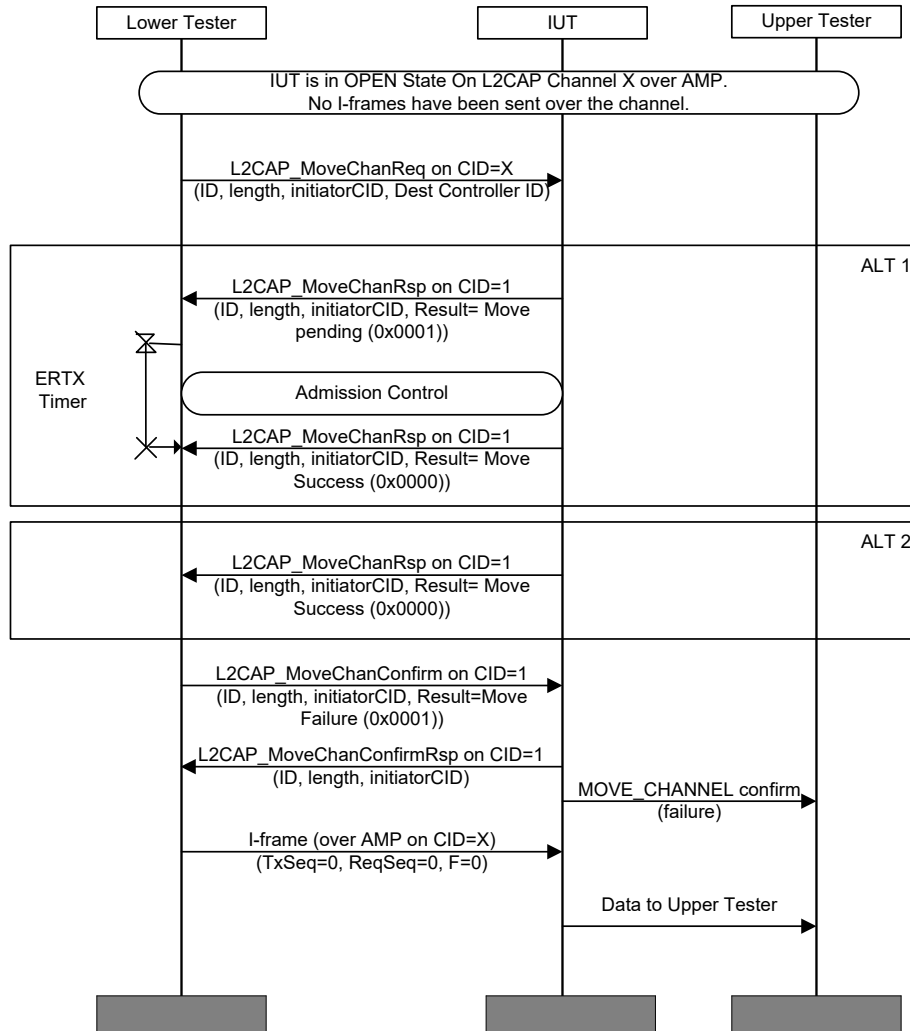

Figure 4.161: L2CAP/MCH/BV-34-C [Move Channel Response for AMP to BR/EDR (STM Sink) – Failed] MSC

- Test Condition

The channel's Extended Flow Specification is valid for a BR/EDR link.

- Expected Outcome

Pass verdict

The IUT passes received data to the Upper Tester after the failed moved operation completes.

L2CAP/MCH/BV-35-C [Move Collision – STM Source]

• Test Purpose

Verify that the IUT can properly handle a move collision when both the IUT and Lower Tester attempt to move a Streaming Mode channel from the BR/EDR link to an AMP link at the same time where the IUT is the data source.

• Reference

[1] 4.16, 4.17, 9.2

• Initial Condition

- An L2CAP Streaming Mode channel exists between the IUT and the Lower Tester. There has been no data transfer on the channel.
- The AMP Physical Link Exists.
- I(out) outgoing I-frames and I(in) incoming I-frames have been sent and received by the IUT over the channel after it was opened and before the test is executed.

- Test Procedure

Figure 4.162 assumes I(out) and I(in) are 0. The actual values of N(S) and N(R) for both incoming and outgoing traffic must take the number of previously sent and received I-frames into account.

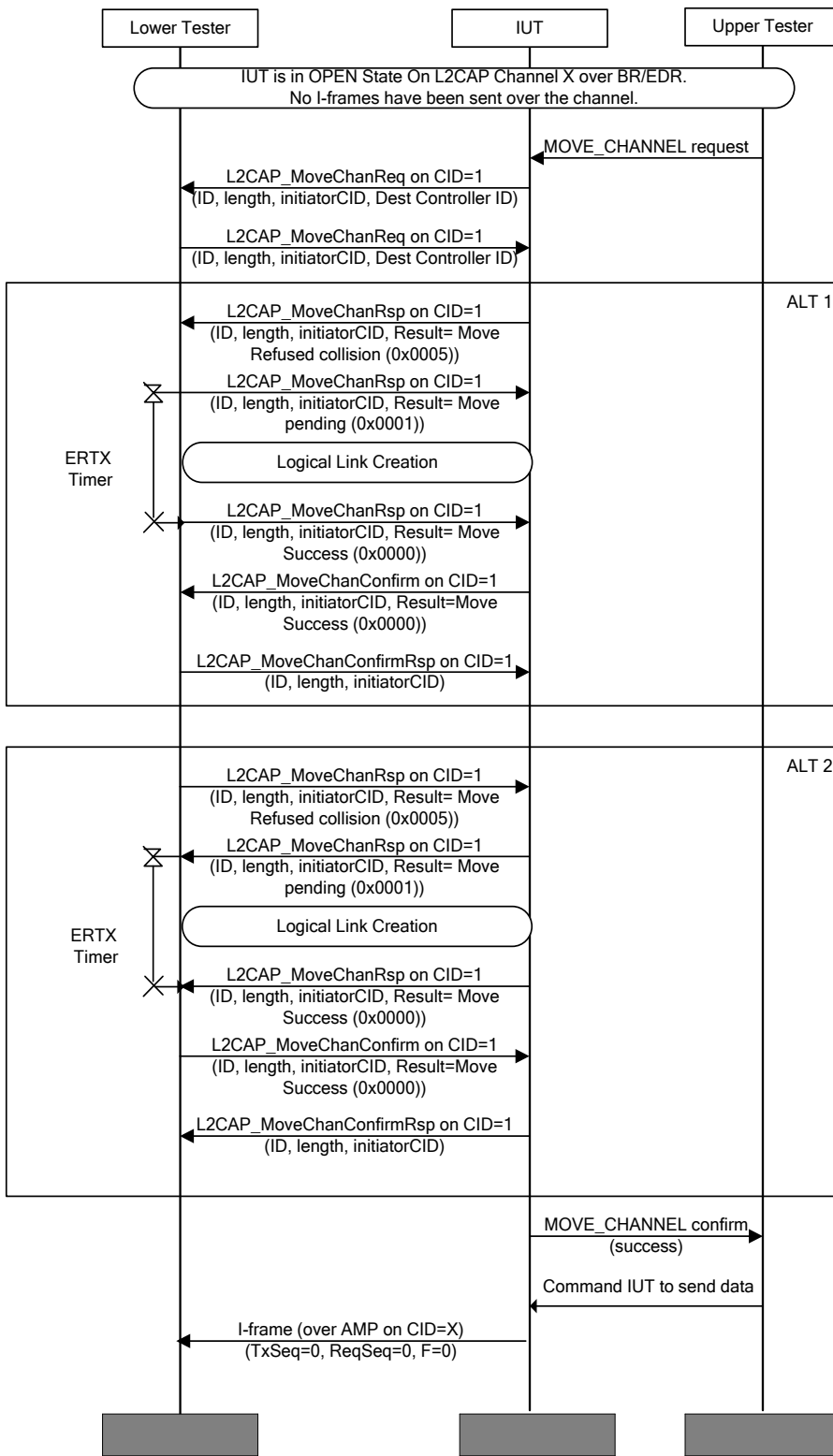

Figure 4.162: L2CAP/MCH/BV-35-C [Move Collision – STM Source] MSC



- Expected Outcome

Pass verdict

Move operation is successful.

ALT1:

The IUT's BD_ADDR is larger than the Lower Tester's BD_ADDR so the IUT sends L2CAP_MOVE_CHANNEL_RSP with result code of "Move refused – Move Channel collision" (0x0005). It sends an I-frame at the end of the move operation over the AMP link.

ALT2:

The IUT's BD_ADDR is smaller than Lower Tester's BD_ADDR so IUT sends L2CAP_MOVE_CHANNEL_RSP with result code of "Move Pending" (0x0001). It sends an I-frame at the end of the move operation over the AMP link.

L2CAP/MCH/BV-36-C [Move Collision – STM Sink]

- Test Purpose

Verify that the IUT can properly handle a move collision when both the IUT and Lower Tester attempt to move a Streaming Mode channel from the BR/EDR link to an AMP link at the same time where the IUT is the data sink.

- Reference

[1] 4.16, 4.17, 9.2

- Initial Condition

- An L2CAP Streaming Mode channel exists between the IUT and the Lower Tester. There has been no data transfer on the channel.
- The AMP Physical Link Exists.
- I(out) outgoing I-frames and I(in) incoming I-frames have been sent and received by the IUT over the channel after it was opened and before the test is executed.

- Test Procedure

Figure 4.163 assumes I(out) and I(in) are 0. The actual values of N(S) and N(R) for both incoming and outgoing traffic must take the number of previously sent and received I-frames into account.

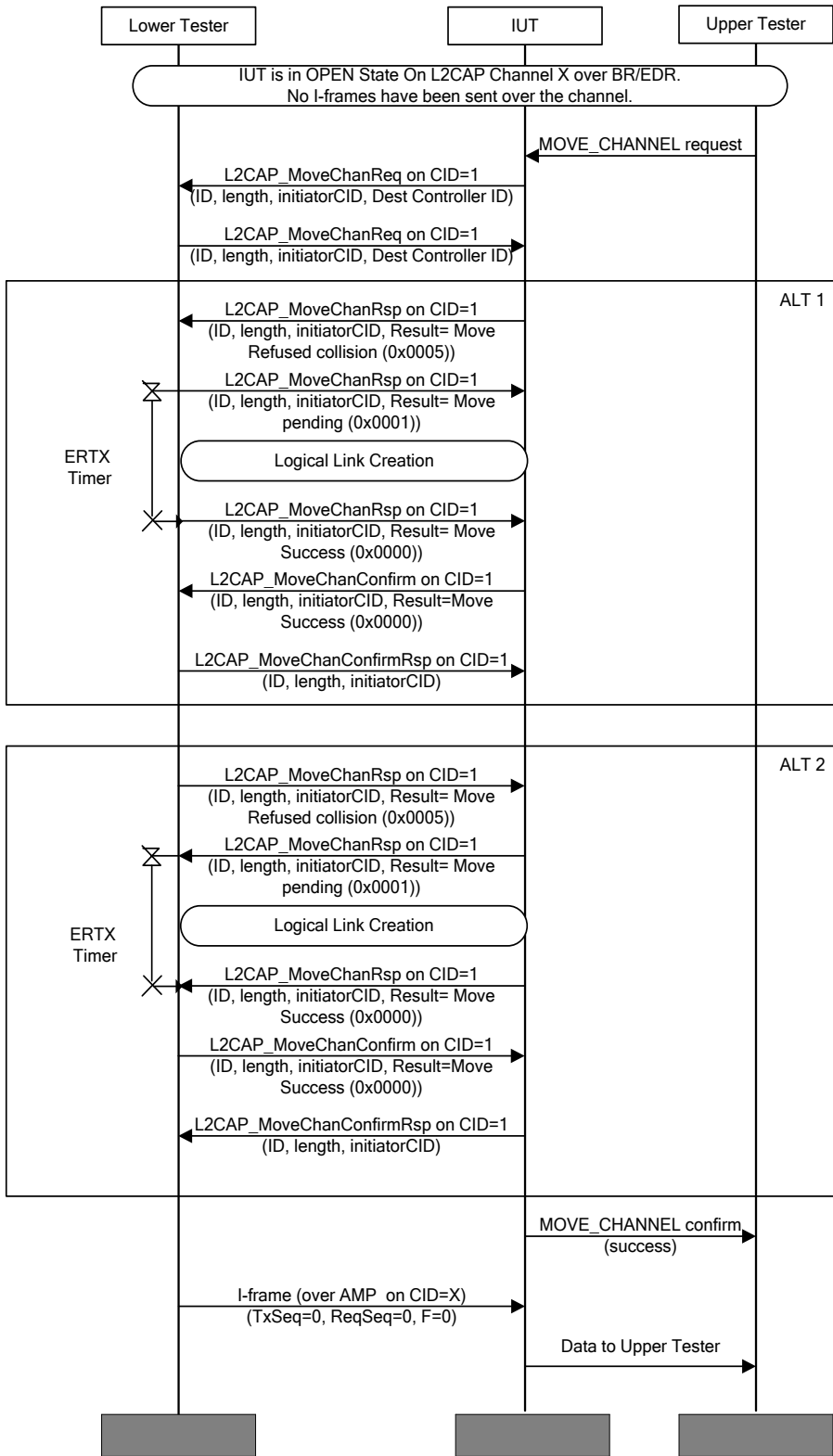

Figure 4.163: L2CAP/MCH/BV-36-C [Move Collision – STM Sink] MSC

- Expected Outcome

Pass verdict

Move operation is successful.

ALT1:

The IUT's BD_ADDR is larger than Lower Tester's BD_ADDR so IUT sends L2CAP_MOVE_CHANNEL_RSP with result code refused - collision (0x0005). It passes the received data to the Upper Tester at the end of the move operation.

ALT 2:

The IUT's BD_ADDR is smaller than the Lower Tester's BD_ADDR so the IUT sends L2CAP_MOVE_CHANNEL_RSP with result code of "Move Pending" (0x0001). It passes the received data to the Upper Tester at the end of the move operation.

4.5.14 Enhanced Retransmission Mode with Extended Control Field (ECF)

Verify the correct implementation of the Extended Control Field with Enhanced Retransmission Mode.

L2CAP/ECF/BV-01-C [Receive I-Frames with Extended Control Field]

- Test Purpose

Verify that the IUT can receive in-sequence valid I-frames with the Extended Control Field and deliver L2CAP SDUs to the Upper Tester.

- Reference

[1] 3.3.2, 8.6

- Initial Condition

- The IUT is in the INFO_TRANSFER state for a data channel with assigned CID.
- The connection is configured as ERTM.
- No I-frames have been received from the Lower Tester.
- The IUT has configured a MTU and MPS size that is greater or equal to 48 bytes.
- I(out) outgoing I-frames and I(in) incoming I-frames have been sent and received by the IUT over the channel after it was opened and before the test is executed.

- Test Procedure

Figure 4.164 assumes I(out) and I(in) are 0. The actual values of N(S) and N(R) for both incoming and outgoing traffic must take the number of previously sent and received I-frames into account.

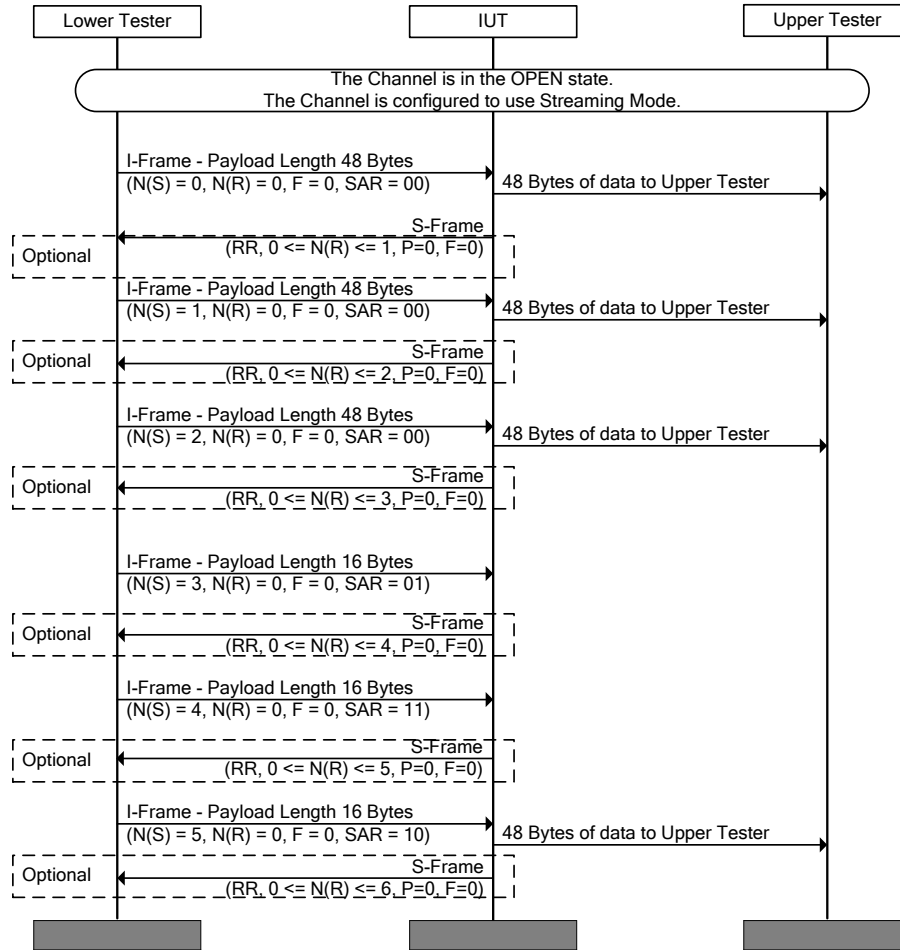

Figure 4.164: L2CAP/ECF/BV-01-C [Receive I-Frames with Extended Control Field] MSC

- Expected Outcome

Pass verdict

Data in the received I-frame(s) match that sent by the Lower Tester.

SAR bits are set per specification.

F-bit is set to 0.

Complete SDU is sent to the Upper Tester.

All S-frames from the IUT contain the Extended Control Field.

L2CAP/ECF/BV-02-C [Transmit I-Frames with Extended Control Field]

- Test Purpose

Verify that the IUT can send correctly formatted sequential I-frames with valid values for the Extended Control Fields (SAR, F-bit, ReqSeq, TxSeq).
- Reference

[1] 3.3.2, 8.6
- Initial Condition
 - The IUT is in the INFO_TRANSFER state for a data channel with assigned CID.
 - The connection is configured as ERTM.
 - I(out) outgoing I-frames and I(in) incoming I-frames have been sent and received by the IUT over the channel after it was opened and before the test is executed.
- Test Procedure

Figure 4.165 assumes I(out) and I(in) are 0. The actual values of N(S) and N(R) for both incoming and outgoing traffic must take the number of previously sent and received I-frames into account.

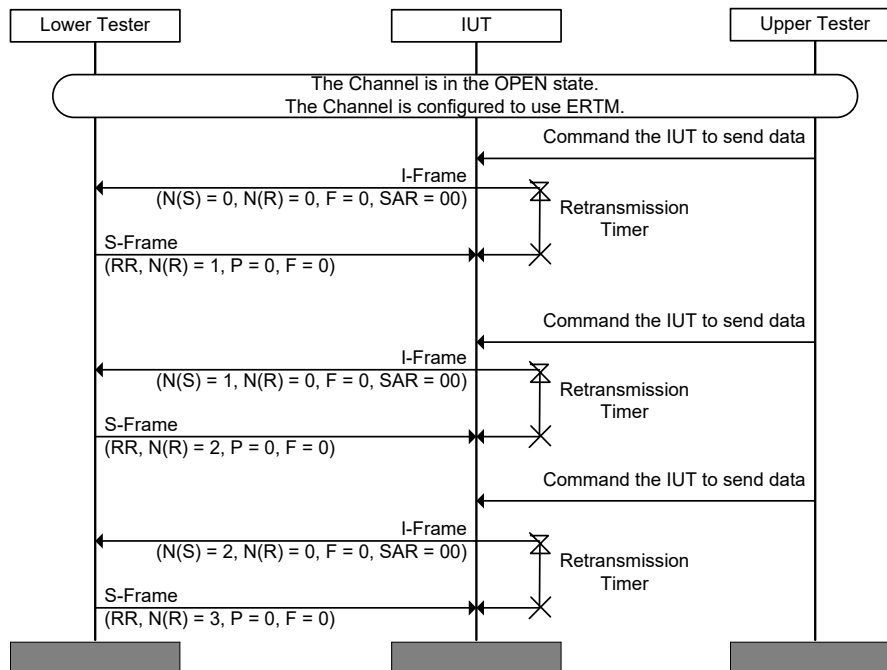

Figure 4.165: L2CAP/ECF/BV-02-C [Transmit I-Frames with Extended Control Field] MSC

- Expected Outcome

Pass verdict

The IUT sends I-frame(s) to the Lower Tester containing Extended Control Field.
Data in the I-frame(s) match that which was provided by the Upper Tester.
SAR bits are set per specification.
F-bit is set to 0.

L2CAP/ECF/BV-03-C [Acknowledging Received I-Frames with Extended Control Field]

- Test Purpose

Verify that the IUT sends S-frame [RR] with Extended Control field and the Poll bit not set to acknowledge data received from the Lower Tester.
- Reference

[1] 3.3.2, 8.6.1.1
- Initial Condition
 - The IUT is in the INFO_TRANSFER state for a data channel with assigned CID. The connection is configured as ERTM. No I-frames have been received from the Lower Tester.
 - I(out) outgoing I-frames and I(in) incoming I-frames have been sent and received by the IUT over the channel after it was opened and before the test is executed.
- Test Procedure

Figure 4.166 assumes I(out) and I(in) are 0. The actual values of N(S) and N(R) for both incoming and outgoing traffic must take the number of previously sent and received I-frames into account.

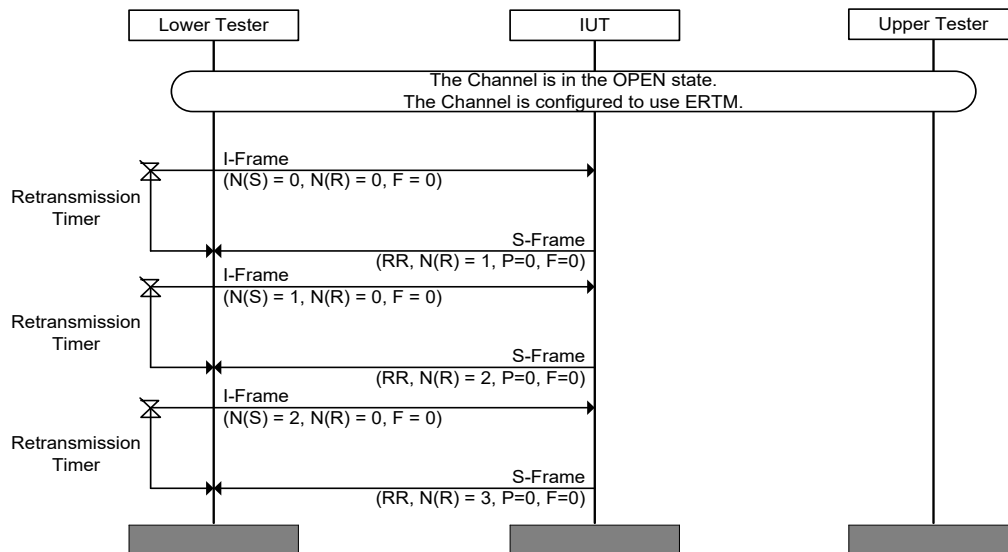

Figure 4.166: L2CAP/ECF/BV-03-C [Acknowledging Received I-Frames with Extended Control Field] MSC

- Expected Outcome

Pass verdict

The IUT sends a Supervisory frame with S=RR, LastAkedReqSeq < ReqSeq <= last received I-frame's TxSeq+1, F=0, P=0, Reserved bits = 0 and Extended Control Field.

L2CAP/ECF/BV-04-C [Send S-Frame [RR] with Extended Control Field and Poll Bit Set]

- Test Purpose

Verify that the IUT sends an S-frame [RR] with the Extended Control field and the Poll bit set when its retransmission timer expires.
- Reference

[1] 3.3.2, 8.6.1.4, 8.6.4



- Initial Condition
 - The channel is in the OPEN state and configured to use ERTM.
 - I(out) outgoing I-frames and I(in) incoming I-frames have been sent and received by the IUT over the channel after it was opened and before the test is executed.
- Test Procedure

Figure 4.167 assumes I(out) and I(in) are 0. The actual values of N(S) and N(R) for both incoming and outgoing traffic must take the number of previously sent and received I-frames into account.

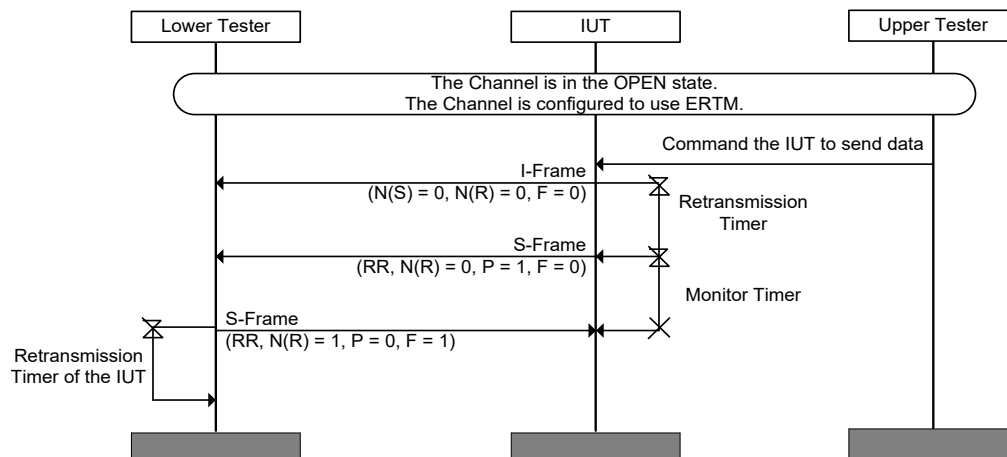

Figure 4.167: L2CAP/ECF/BV-04-C [Send S-Frame [RR] with Extended Control Field and Poll Bit Set] MSC

- Expected Outcome

Pass verdict

The IUT sends an S-frame with Extended Control Field and with the POLL bit set after the IUT Retransmission Timer (as specified by Lower Tester during configuration) expires.

The IUT does not retransmit the I-frame after receiving an S-frame from the Lower Tester that acknowledges the previously sent I-frame.

L2CAP/ECF/BV-05-C [Respond to S-Frame [REJ] with Extended Control Field]

- Test Purpose

Verify that the IUT retransmits I-frames with Extended Control Field starting from the sequence number specified in the S-frame [REJ] with an Extended Control Field.
- Reference

[1] 3.3.2, 8.6.1.2, 8.6.4
- Initial Condition
 - The channel is in the OPEN state and configured to use ERTM.
 - I(out) outgoing I-frames and I(in) incoming I-frames have been sent and received by the IUT over the channel after it was opened and before the test is executed.
 - The MaxTransmit for the IUT is set to a value greater than 1.
 - The Lower Tester has specified a value for TxWin that is greater than 1 in the Configure Request sent to the IUT.

- Test Procedure

Figure 4.168 assumes I(out) and I(in) are 0. The actual values of N(S) and N(R) for both incoming and outgoing traffic must take the number of previously sent and received I-frames into account.

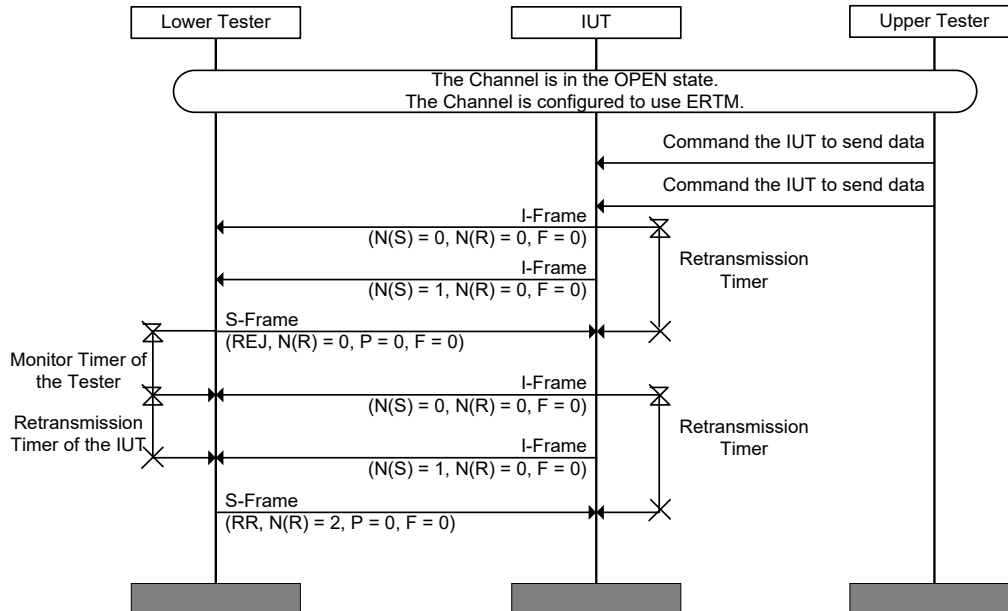

Figure 4.168: L2CAP/ECF/BV-05-C [Respond to S-Frame [REJ] with Extended Control Field] MSC

- Expected Outcome

Pass verdict

The IUT retransmits the first I-frame requested in the REJ from the Lower Tester before the Monitor Timer of the Lower Tester expires, including the Extended Control Field.

The IUT retransmits the second I-frame requested in the REJ from the Lower Tester before the IUT Retransmission Timer expires.

L2CAP/ECF/BV-06-C [Respond to S-Frame [SREJ] with Extended Control Field and POLL bit Set]

- Test Purpose

Verify that the IUT responds with the correct I-frame when sent an SREJ frame with an Extended Control Field. Verify that the IUT processes the acknowledgment of previously unacknowledged I-frames.

- Reference

[1] 3.3.2, 8.6.1.3, 8.6.4

- Initial Condition

- The channel is in the OPEN state and configured to use ERTM.
- I(out) outgoing I-frames and I(in) incoming I-frames have been sent and received by the IUT over the channel after it was opened and before the test is executed.
- The MaxTransmit for the IUT is set to a value greater than 1.
- The Lower Tester has specified a value for TxWin of 3 in the Configure Request sent to the IUT.

- Test Procedure

Figure 4.169 assumes I(out) and I(in) are 0. The actual values of N(S) and N(R) for both incoming and outgoing traffic must take the number of previously sent and received I-frames into account.

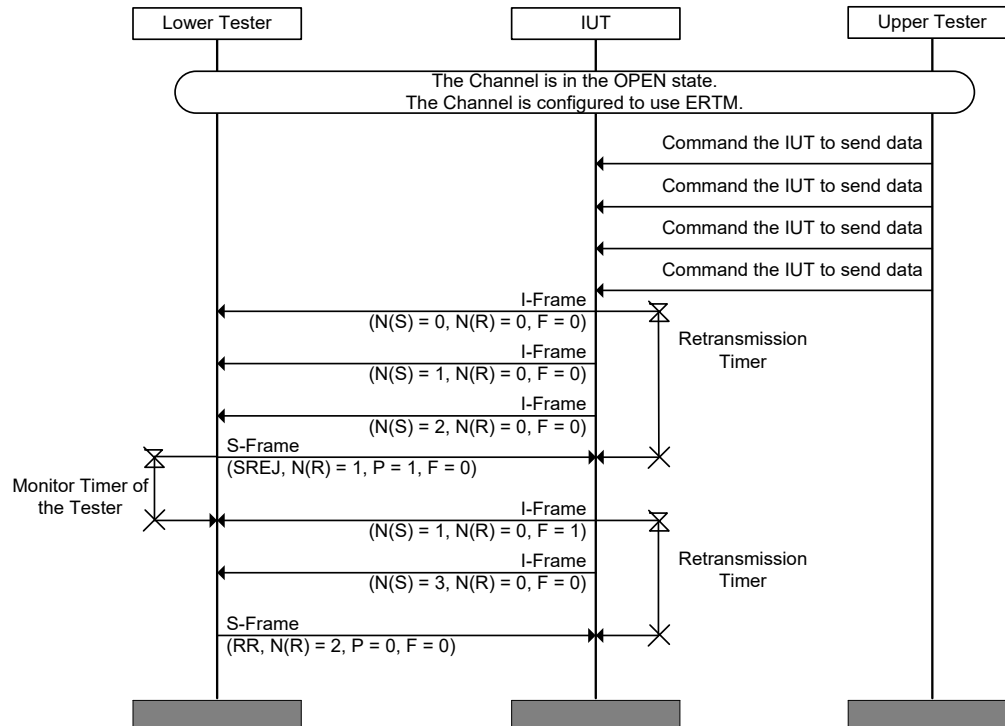

Figure 4.169: L2CAP/ECF/BV-06-C [Respond to S-Frame [SREJ] with Extended Control Field and POLL bit Set] MSC

- Expected Outcome

Pass verdict

The IUT retransmits the I-frame requested in the SREJ from the Lower Tester before the Monitor Timer of the Lower Tester expires.

The I-frame retransmitted by the IUT has the Final bit = 1, and the Extended Control Field.

The IUT processes the acknowledgment of the first I-frame (N(S) = 0) from the SREJ received and consequently send the pending I-frame (N(S) = 3).

L2CAP/ECF/BV-07-C [Respond to S-Frame [SREJ] with Extended Control Field and POLL Bit Clear]

- Test Purpose

Verify that the IUT responds with the correct I-frame when sent an SREJ frame with an Extended Control Field.

- Reference

[1] 3.3.2, 8.6.1.3, 8.6.4

- Initial Condition
 - The channel is in the OPEN state and configured to use ERTM.
 - I(out) outgoing I-frames and I(in) incoming I-frames have been sent and received by the IUT over the channel after it was opened and before the test is executed.
 - The MaxTransmit for the IUT is set to a value greater than 1.
 - The Lower Tester has specified a value for TxWin of 3 in the Configure Request sent to the IUT.

Test Procedure

Figure 4.170 assumes I(out) and I(in) are 0. The actual values of N(S) and N(R) for both incoming and outgoing traffic must take the number of previously sent and received I-frames into account.

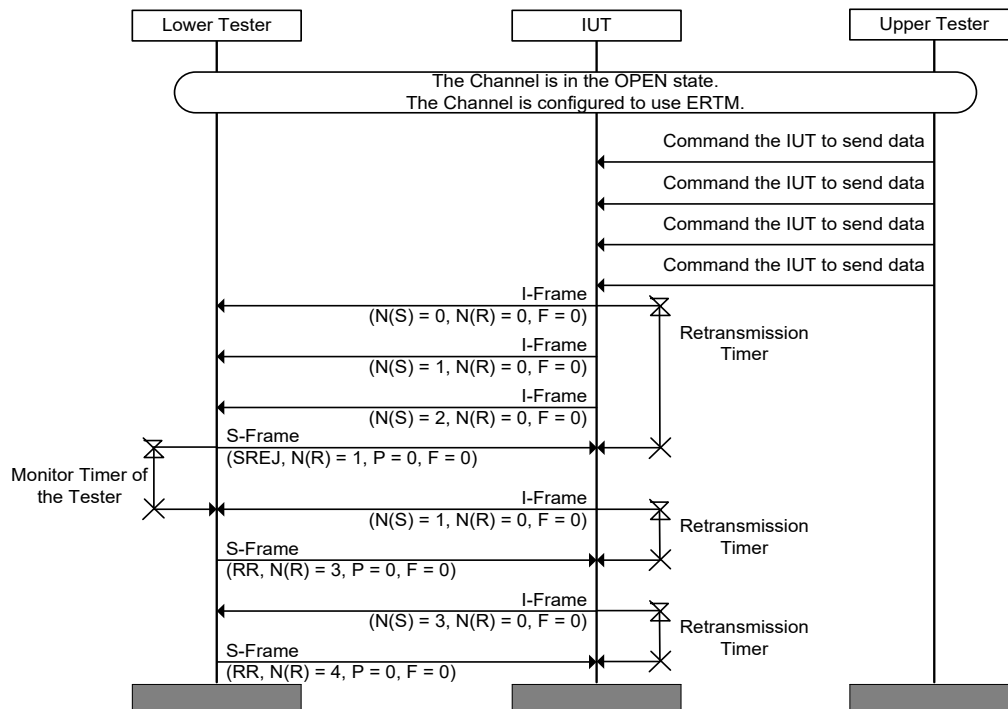

Figure 4.170: L2CAP/ECF/BV-07-C [Respond to S-Frame [SREJ] with Extended Control Field and POLL Bit Clear] MSC

Expected Outcome

Pass verdict

The IUT retransmits the I-frame, including an Extended Control Field, requested in the SREJ from the Lower Tester before the Monitor Timer of the Lower Tester expires.

The IUT does not transmit I-frame (N(S) = 3) as a result of receiving the SREJ from the Lower Tester.

L2CAP/ECF/BV-08-C [Transmit I-Frames using Extended Control Field and SAR]

Test Purpose

Verify that the IUT can send correctly formatted sequential I-frames with valid values for the extended control fields (SAR, F-bit, ReqSeq, TxSeq) when performing SAR.

Reference

[1] 3.3.2



- Initial Condition
 - The connection is configured as ERTM.
 - I(out) outgoing I-frames and I(in) incoming I-frames have been sent and received by the IUT over the channel after it was opened and before the test is executed.
 - The Lower Tester has configured a value for the MPS that ensures that the IUT performs SAR. The Lower Tester uses "TSPX_iut_sdu_size_in_bytes" as the value SDUs of N bytes that the IUT sends the Lower Tester.
 - The Lower Tester has configured a TxWindow size of 1.
- Test Procedure

Figure 4.171 assumes I(out) and I(in) are 0. The actual values of N(S) and N(R) for both incoming and outgoing traffic must take the number of previously sent and received I-frames into account.

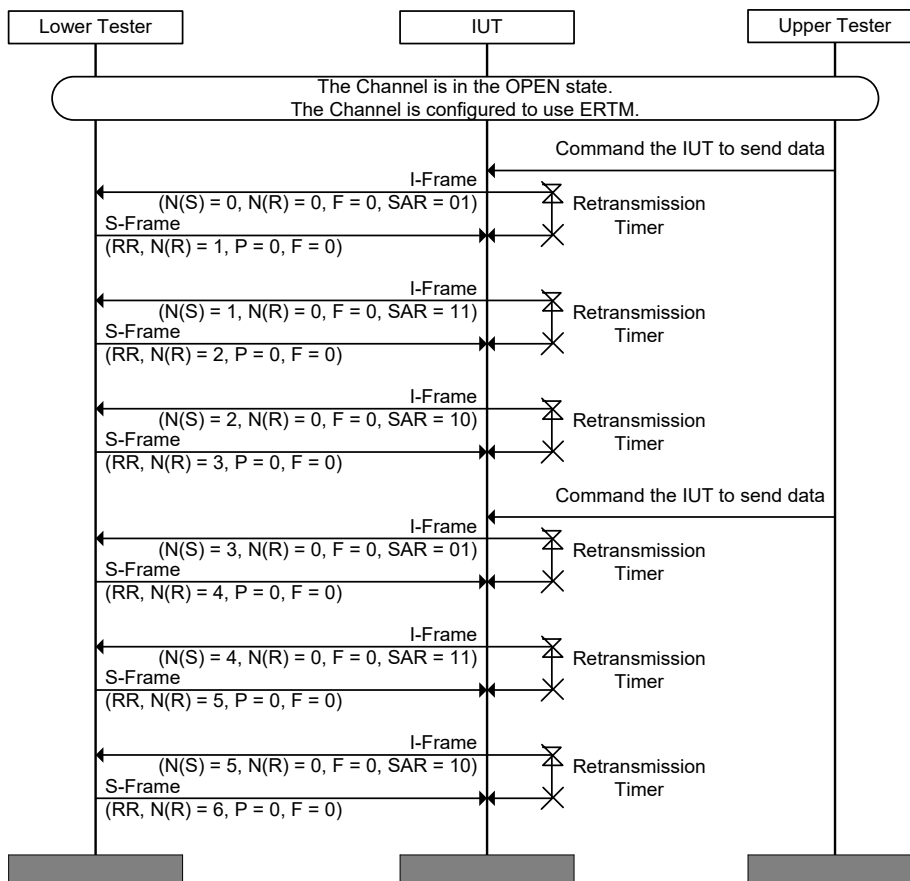

Figure 4.171: L2CAP/ECF/BV-08-C [Transmit I-Frames using Extended Control Field and SAR] MSC

- Expected Outcome

Pass verdict

The Lower Tester receives six correctly formatted I-frames from the IUT including an Extended Control Field.

4.5.15 Streaming Mode with Extended Control Field (STM)

Verify the correct implementation of the Extended Control Field with Streaming Mode.

L2CAP/STM/BV-11-C [Streaming Mode Source with Extended Control Field]

- Test Purpose

Verify that the IUT can send correctly formatted sequential I-frames with valid values for the Extended Control fields (SAR, F-bit, ReqSeq, TxSeq).

- Reference

[1] 3.3.2, 8.7

- Initial Condition

- The channel is in the OPEN state and configured to use Streaming Mode.
- I(out) outgoing I-frames and I(in) incoming I-frames have been sent and received by the IUT over the channel after it was opened and before the test is executed.

- Test Procedure

Figure 4.172 assumes I(out) and I(in) are 0. The actual values of N(S) and N(R) for both incoming and outgoing traffic must take the number of previously sent and received I-frames into account.

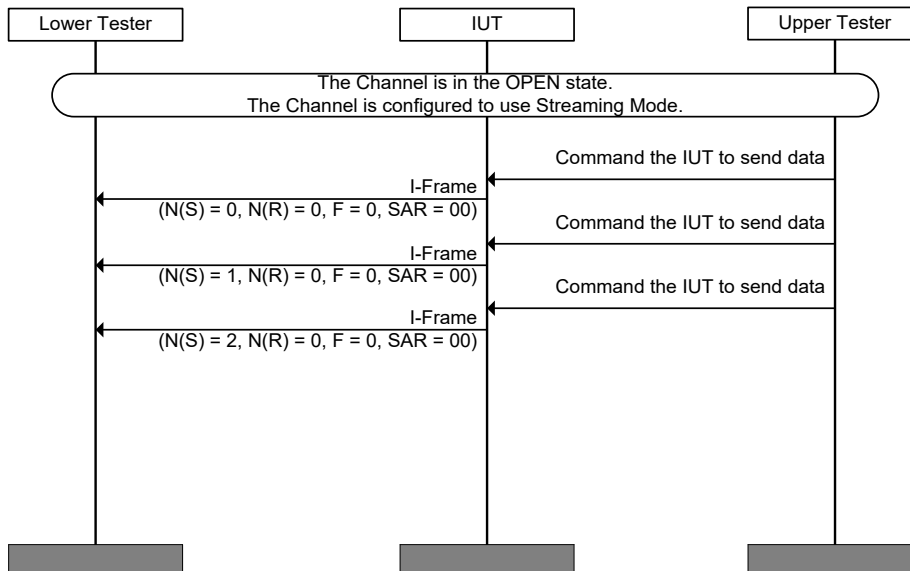

Figure 4.172: L2CAP/STM/BV-01-C [Streaming Mode Source with Extended Control Field] MSC

- Expected Outcome

Pass verdict

The Lower Tester receives three correctly formatted I-frames from the IUT including Extended Control Fields.

L2CAP/STM/BV-12-C [Streaming Mode Sink with Extended Control Field]

- Test Purpose

Verify that the IUT receives I-frames with Extended Control Field and handles SAR correctly.
- Reference

[1] 3.3.2, 8.7
- Initial Condition
 - The channel is in the OPEN state and configured to use Streaming Mode.
 - I(out) outgoing I-frames and I(in) incoming I-frames have been sent and received by the IUT over the channel after it was opened and before the test is executed.
 - The IUT has configured a MTU and MPS size that is greater or equal to 48 bytes.
- Test Procedure

Figure 4.173 assumes I(out) and I(in) are 0. The actual values of N(S) and N(R) for both incoming and outgoing traffic must take the number of previously sent and received I-frames into account.

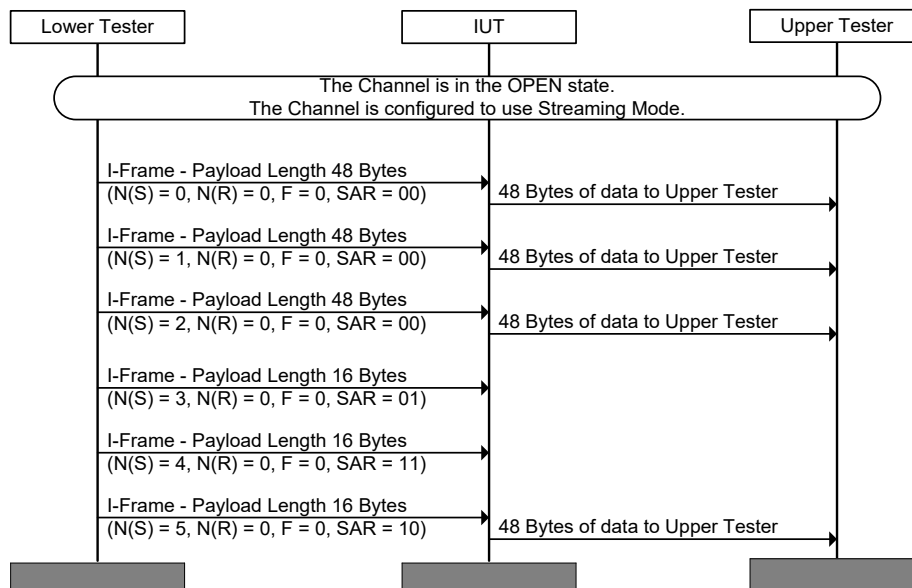

Figure 4.173: L2CAP/STM/BV-02-C [Streaming Mode Sink with Extended Control Field] MSC

- Expected Outcome

Pass verdict

The IUT passes the received data correctly to the Upper Tester.

L2CAP/STM/BV-13-C [Streaming Mode Source using Extended Control Field and SAR]

- Test Purpose

Verify that the IUT can send correctly formatted sequential I-frames with valid values for the Extended Control fields (SAR, F-bit, ReqSeq, TxSeq) while performing SAR.
- Reference

[1] 3.3.2, 8.7

- Initial Condition
 - The channel is in the OPEN state and configured to use Streaming Mode.
 - I(out) outgoing I-frames and I(in) incoming I-frames have been sent and received by the IUT over the channel after it was opened and before the test is executed.
 - The Lower Tester has configured a value for the MPS that ensures the IUT performs SAR. The Lower Tester uses "TSPX_iut_sdu_size_in_bytes" as the value SDUs of N bytes that the IUT sends the Lower Tester.
- Test Procedure

Figure 4.174 assumes I(out) and I(in) are 0. The actual values of N(S) and N(R) for both incoming and outgoing traffic must take the number of previously sent and received I-frames into account.

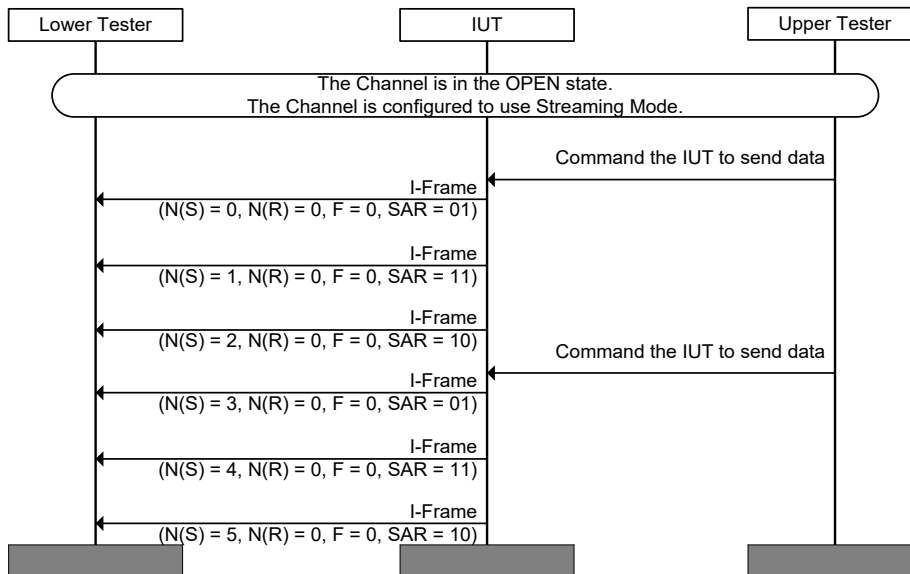

Figure 4.174: L2CAP/STM/BV-13-C [Streaming Mode Source using Extended Control Field and SAR] MSC

- Expected Outcome

Pass verdict

The Lower Tester receives six correctly formatted I-frames from the IUT, including Extended Control Fields.

4.6 Low Energy System tests

Verify the correct implementation of the LE features of L2CAP.

4.6.1 Connection Parameter Update

Verify the correct implementation of the LE connection parameter update feature.

L2CAP/LE/CPU/BV-01-C [Send Connection Parameter Update Request]

- Test Purpose

Verify that the IUT can send the connection parameter update Request to Lower Tester when acting as a Peripheral device.

- Reference

[11] Table 2.1, Table 6.1, 4.20

- Initial Condition

- The Lower Tester acts as a connection initiator and the IUT acts as an advertiser.
- The IUT is in CLOSED state for data channel. No ACL link is established.
- The Lower Tester's LL feature mask indicates that it does not support the Connection Parameters Request Procedure.
- The Lower Tester becomes a Central device and the IUT becomes a Peripheral device after the connection is established.
- For the parameters to send and receive, see [5].

- Test Procedure

1. ACL link is established.
2. The IUT sends L2CAP_CONNECTION_PARAMETER_UPDATE_REQ.

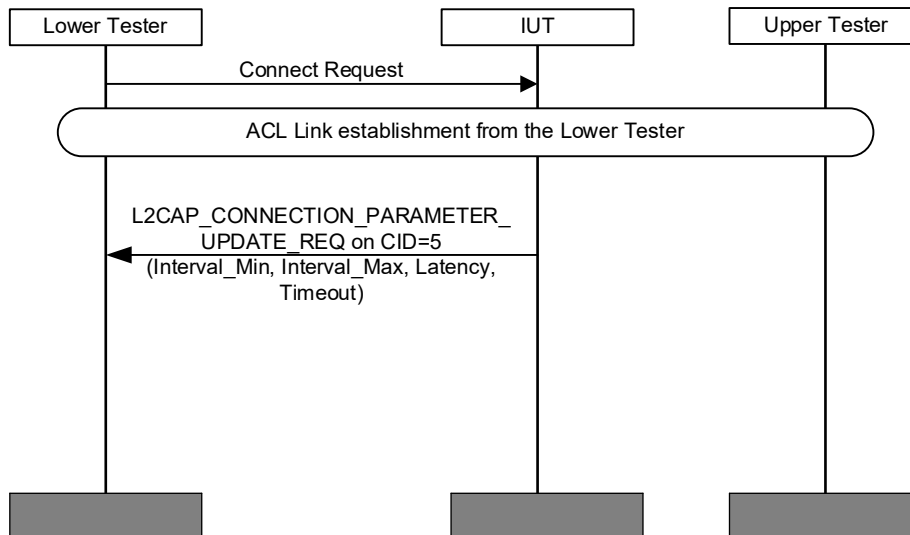

Figure 4.175: L2CAP/LE/CPU/BV-01-C [Send Connection Parameter Update Request] MSC

- Expected Outcome

Pass verdict

The IUT transmits L2CAP_CONNECTION_PARAMETER_UPDATE_REQ over the LE signaling channel.

L2CAP/LE/CPU/BV-02-C [Accept Connection Parameter Update Request]

- Test Purpose

Verify that the IUT can receive and handle a request for connection parameter update when acting as a Central device.

- Reference

[11] Table 6.1, 4.20, 4.21

- Initial Condition
 - The IUT is in CLOSED state. No ACL link exists. The IUT acts as L2CAP initiator.
- Test Procedure

ACL link establishment is part of the test case.

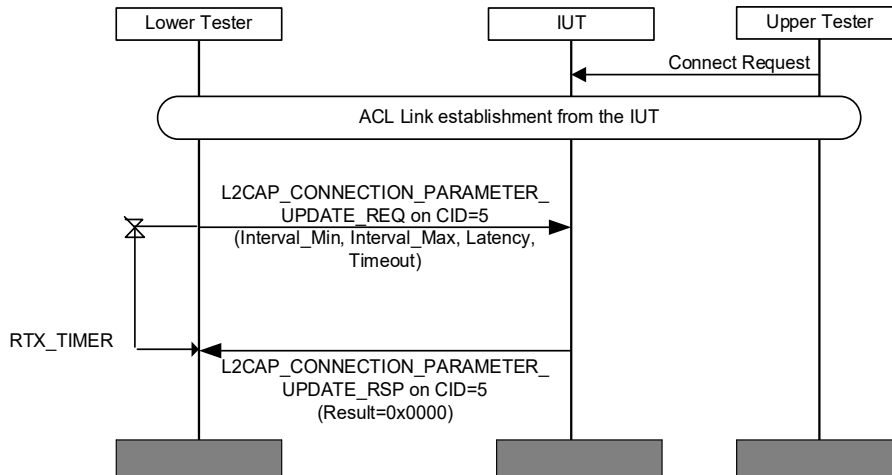

Figure 4.176: L2CAP/LE/CPU/BV-02-C [Accept Connection Parameter Update Request] MSC

- Test Condition

The IUT's Bluetooth device address BD_ADDR is defined. For parameter to send and receive, see [5].

The IUT works as connection initiator, therefore, the IUT becomes a Central device and the Lower Tester acts as a Peripheral device after the connection is established.
- Expected Outcome

Pass verdict

The IUT sends a correct L2CAP_CONNECTION_PARAMETER_UPDATE_RSP over LE signaling channel before RTX timer expires with result code 0x0000.
- Notes

The Lower Tester's RTX timer is set to maximum allowed initial value.

L2CAP/LE/CPU/BI-01-C [Reject Connection Parameter Update Parameters]

- Test Purpose

Verify that the IUT can reject a request for connection parameter update with illegal parameters.
- Reference

[11] Table 6.1, 4.20, 4.21
- Initial Condition
 - The IUT is in CLOSED state. No ACL link exists. The IUT acts as L2CAP initiator.

- Test Procedure

ACL link establishment is part of the test case.

The Lower Tester sends a Latency of larger than 500 in ConnectionParameterUpdateReq.

The IUT returns result of reject in ConnectionParameterUpdateRsp.

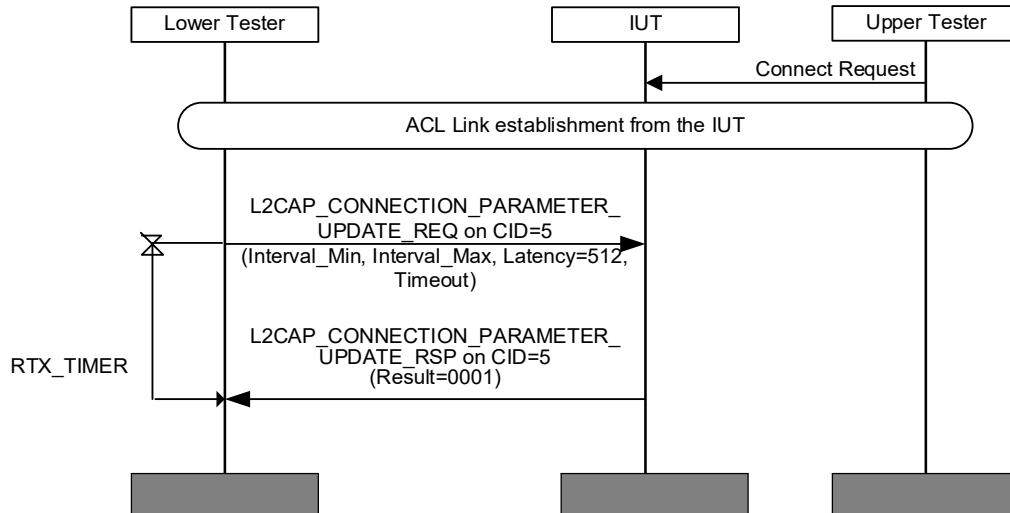

Figure 4.177: L2CAP/LE/CPU/BI-01-C [Reject Connection Parameter Update Parameters] MSC

- Test Condition

The IUT's Bluetooth device address BD_ADDR is defined. For parameter to send and receive, see [5].

The IUT works as connection initiator, therefore the IUT becomes a Central device and the Lower Tester as a Peripheral device after the connection is established.

- Expected Outcome

Pass verdict

The IUT sends a correct L2CAP_CONNECTION_PARAMETER_UPDATE_RSP with result code 0x0001 over LE signaling channel before RTX timer expires.

- Notes

The Lower Tester's RTX timer is set to maximum allowed initial value.

L2CAP/LE/CPU/BI-02-C [Reject Connection Parameter Update Request]

- Test Purpose

Verify that the IUT can reject a request for connection parameter update in Peripheral mode.

- Reference

[11] Table 6.1, 4.20, 4.21

- Initial Condition

- The IUT is in CLOSED state. No ACL link exists. The IUT acts as L2CAP acceptor.

- Test Procedure

ACL link establishment is part of the test case.

The Lower Tester sends ConnectionParameterUpdateReq over the LE signaling channel.

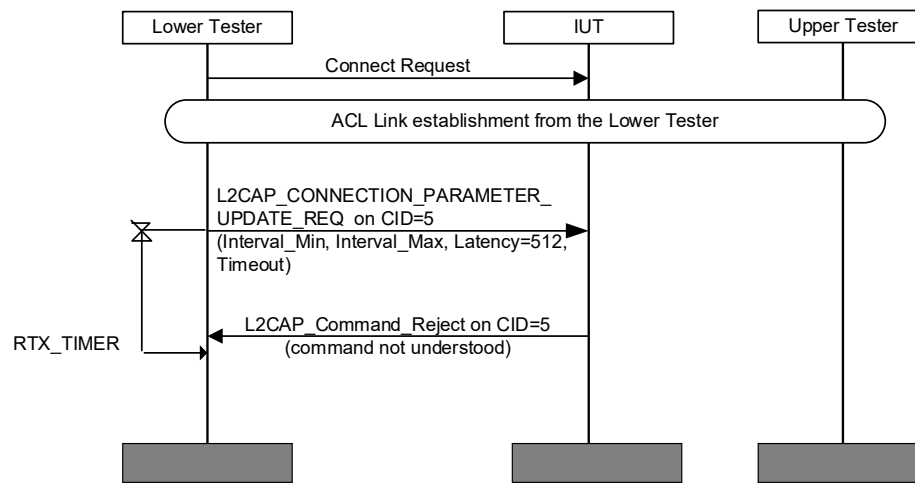

Figure 4.178: L2CAP/LE/CPU/BI-02-C [Reject Connection Parameter Update Request] MSC

- Test Condition

The IUT's Bluetooth device address BD_ADDR is defined. For parameter to send and receive, see [5].

The Lower Tester acts as connection initiator, therefore the IUT becomes a Peripheral device and the Lower Tester acts as a Central device after the connection is established.

- Expected Outcome

Pass verdict

The IUT sends L2CAP Command_Reject with reason "Command not understood" over the LE signaling channel before RTX timer expires.

- Notes

The Lower Tester's RTX timer is set to maximum allowed initial value.

4.6.2 Command Reject

Verify the correct implementation of the command reject.

4.6.2.1 Reject Unknown Command

- Test Purpose

Verify that the IUT can reject reserved and unknown commands.

- Reference

[11] 4.10

[12] 4, Table 4.2

- Initial Condition

- The appropriate signaling channel for the transport is used as specified in Table 4.26.

- Test Case Configuration

Test case	L2CAP/COS/CED/BI-01-C [Reject Unknown Command, BR/EDR]	L2CAP/LE/REJ/BI-02-C [Reject Unknown Command – LE]
Signaling Channel	0x0001	0x0005
RFU Codes	0x1B to 0xFF	0x1B to 0xFF
Unsupported Request and Indication Codes	0x12 and 0x14 0x06 IF NOT L2CAP 2/45 0x08 IF NOT L2CAP 2/4 0x0A IF NOT L2CAP 2/6 0x0C, 0x0E, and 0x10 IF NOT L2CAP 2/29 0x16, 0x17, and 0x19 IF NOT L2CAP 2/48a	0x02, 0x04, 0x08, 0x0A, 0x0C, 0x0E, 0x10 0x06 IF NOT L2CAP 2/45a 0x12 IF NOT L2CAP 2/43 0x14 IF NOT L2CAP 2/46 0x16 IF NOT (L2CAP 2/46 OR L2CAP 2/48b) 0x17 and 0x19 IF NOT L2CAP 2/48b
Unsupported Response Codes	0x13 and 0x15 0x07 IF NOT L2CAP 2/45 0x09 IF NOT L2CAP 2/4 0x0B IF NOT L2CAP 2/6 0x0D, 0x0F, and 0x11 IF NOT L2CAP 2/29 0x18 and 0x1A IF NOT L2CAP 2/48a	0x03, 0x05, 0x09, 0x0B, 0x0D, 0x0F, and 0x11 0x07 IF NOT L2CAP 2/45a 0x13 IF NOT L2CAP 2/42 0x15 IF NOT L2CAP 2/46 0x18 and 0x1A IF NOT L2CAP 2/48b

Table 4.26: Reject Unknown Command test cases

- Test Procedure

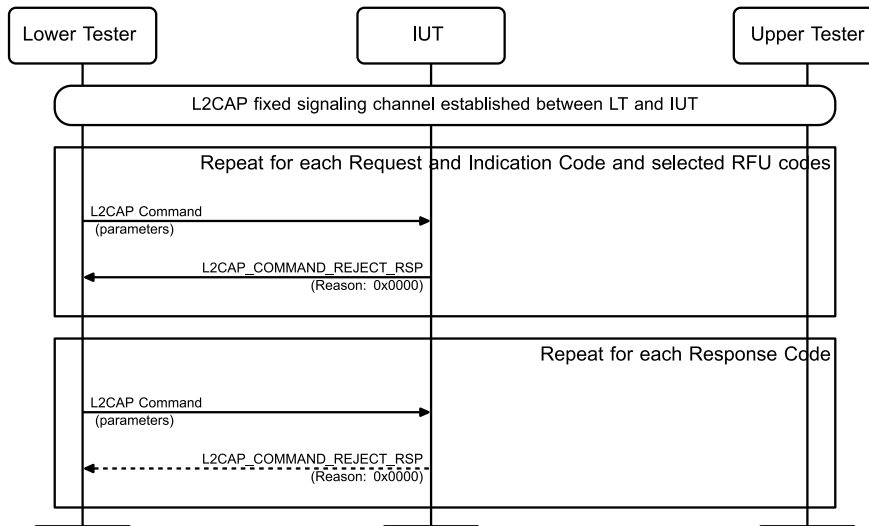

Figure 4.179: Reject Unknown Command MSC

Repeat Steps 1 and 2 for every Unsupported Request and Indication Code based on the ICS support of the IUT in Table 4.26, for the first three RFU Codes in Table 4.26, and for three other RFU Codes in Table 4.26 selected at random.

1. The Lower Tester sends an L2CAP command with the Code defined in Table 4.26.
2. The IUT responds with an L2CAP_COMMAND_REJECT_RSP.

Repeat Steps 3 and 4 for every Unsupported Response Code based on the ICS support of the IUT in Table 4.26.

3. The Lower Tester sends an L2CAP command with the Response Code.
4. The IUT either responds with an L2CAP_COMMAND_REJECT_RSP or does not respond.

- Expected Outcome

Pass verdict

In Step 2, and in Step 4 if the IUT responds, the IUT sends a correct L2CAP_COMMAND_REJECT_RSP packet with reason “Command not understood” and no Reason Data field over the transport and signaling channel as specified in Table 4.26.

4.7 Connectionless Basic L2CAP Mode

Verify the correct implementation of the connectionless services of the L2CAP layer.

4.7.1 Connectionless Reception Channel CLR

Verify the procedures for data exchange over the connectionless channel with the subgroups send data, receive data, disable and enable connectionless traffic.

L2CAP/CLS/CLR/BV-01-C [Data Over Connectionless Channel]

- Test Purpose
 - Verify that the IUT can send data over the connectionless channel.
- Reference
 - [12] 3.2
- Initial Condition
 - The Lower Tester utilizes version L2CAP Basic Mode.
 - The IUT works as Central, a group has been created, and the Lower Tester has been added as member in the group.
- Test Procedure

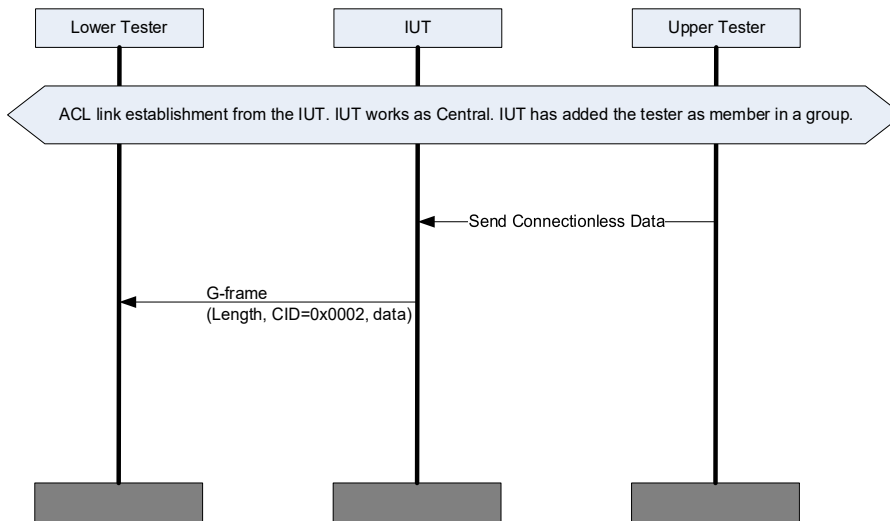

Figure 4.180: L2CAP/CLS/CLR/BV-01-C [Data Over Connectionless Channel] MSC

- Expected Outcome

Pass verdict

The IUT sends connectionless G-frame to the Lower Tester.

L2CAP/CLS/UCD/BV-01-C [Data Reception over Unicast Connectionless Channel]

- Test Purpose

Verify that the IUT has the UCD bit set in the L2CAP Extended Features Mask to indicate support for reception of unicast connectionless data. Also verify that the IUT can receive data over the connectionless channel.

- Reference

[12] 3.2 and 7.6

- Initial Condition

- An ACL connection exists between the Lower Tester and the IUT.

- Test Procedure

The Lower Tester requests Extended Features Mask using L2CAP Information Request. The Lower Tester then transmits a G-frame over the air to the IUT.

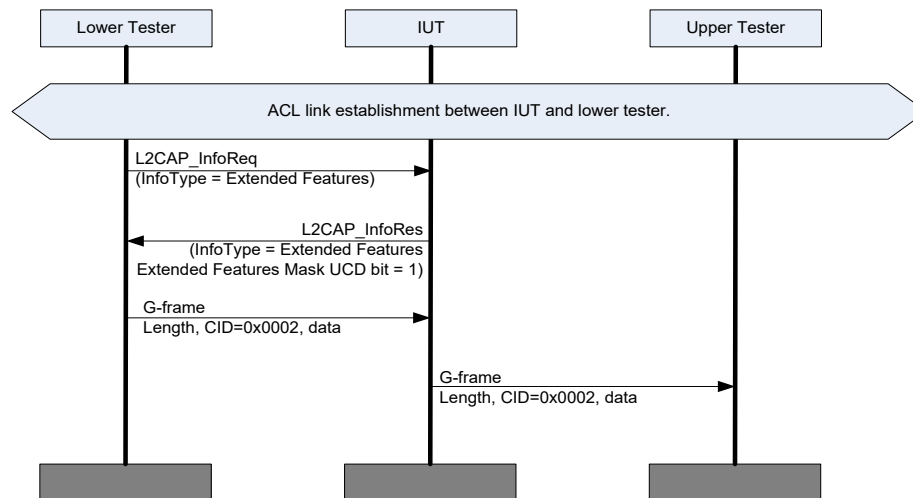

Figure 4.181: L2CAP/CLS/UCD/BV-01-C [Data Reception over Unicast Connectionless Channel] MSC

- Expected Outcome

Pass verdict

The following conditions are met:

- The L2CAP Extended Features Mask is successfully retrieved.
- The Unicast Connectionless Data Reception bit in the L2CAP Extended Features Mask is set.
- The IUT sends a connectionless G-frame to the Upper Tester.

L2CAP/CLS/UCD/BV-02-C [Unencrypted data transmission over unicast connectionless channel]

- Test Purpose

Verify that the IUT can send unencrypted data over the connectionless channel.

Verify that the IUT can correctly send unencrypted G-frames to the Lower Tester.

- Reference

[12] 7.6



- Initial Condition
 - An ACL connection exists between the Lower Tester and the IUT.
- Test Procedure

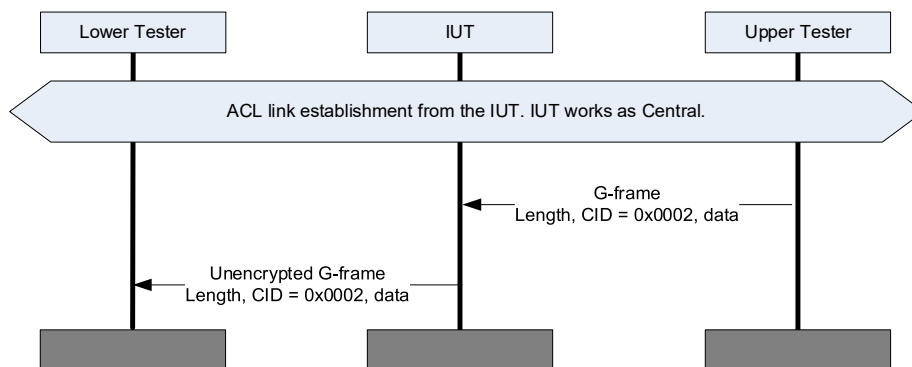

Figure 4.182: L2CAP/CLS/UCD/BV-02-C [Unencrypted data transmission over unicast connectionless channel] MSC

- Expected Outcome
 - Pass verdict
 - The IUT sends an unencrypted connectionless G-frame to the Lower Tester.

L2CAP/CLS/UCD/BV-03-C [Encrypted Data Transmission over Unicast Connectionless Channel]

- Test Purpose
 - Verify that the IUT can send data over the connectionless channel.
- Reference
 - [12] 7.6
- Initial Condition
 - An unencrypted ACL connection exists between the Lower Tester and the IUT.

• Test Procedure

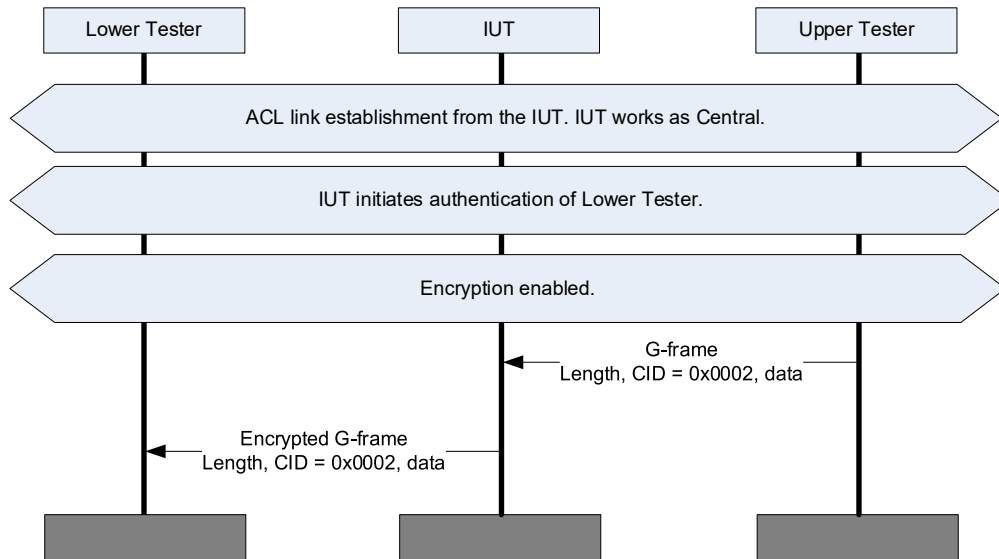

Figure 4.183: L2CAP/CLS/UCD/BV-03-C [Encrypted Data Transmission over Unicast Connectionless Channel] MSC

• Expected Outcome

Pass verdict

The IUT performs the following in the specified order:

1. Authenticates the link.
2. Enables encryption.
3. Sends an encrypted connectionless G-frame to the Lower Tester.

4.8 Channel Identifiers (CID)

Tests that L2CAP in the IUT handles CIDs correctly on the connections to the same remote device.

L2CAP/LE/CID/BV-01-C [Receiving DCID over BR/EDR and LE]

• Test Purpose

Tests that the L2CAP entity can receive the same DCID in L2CAP connect responses on both the BR/EDR and LE links.

• Reference

[12] 2.1

• Initial Condition

- An ACL-U logical link exists between the IUT and Lower Tester.
- An LE-U logical link exists between the IUT and Lower Tester.
- The IUT has determined from TSPX_psm or TSPX_spsm IXIT values, or SDP and GATT, available PSMs and SPSMs on the Lower Tester.
- The Lower Tester has the same public Bluetooth address on the BR/EDR and LE physical transports.

- Test Procedure
 1. The Upper Tester commands the IUT to create an L2CAP connection on the ACL-U logical link to the Lower Tester.
 2. The IUT issues an L2CAP Connection Request over the ACL-U logical link to a known PSM on the Lower Tester, using any allowable dynamically allocated CID in the range 0x0040–0xFFFF for the SCID.
 3. The Lower Tester sends an L2CAP Connection Response and assigns any allowable dynamically allocated CID in the range 0x0040–0xFFFF for the DCID to complete the L2CAP connection.
 4. The Upper Tester commands the IUT to create an L2CAP connection on the LE-U logical link to the Lower Tester.
 5. The IUT issues an L2CAP LE Credit Based Connection Request over the LE-U logical link to a known SPSM on the Lower Tester, using any allowable dynamically allocated CID in the range 0x0040–0x007F for the SCID.
 6. The Lower Tester sends an LE Credit Based Connection Response and assigns the same CID used in Step 3 for the DCID to complete the LE L2CAP connection.
 7. The Upper Tester commands the IUT to transfer data, of different content, over both L2CAP connections.
 8. The Lower Tester displays received data along with the identification of which L2CAP channel it was transferred over.
 9. The Lower Tester issues an L2CAP Disconnection Request over the ACL-U logical link.
 10. The Lower Tester issues an L2CAP Disconnection Request over the LE-U logical link.

- Expected Outcome

Pass verdict

Both L2CAP connections complete successfully.

Correct data for each channel is transferred successfully over both connections.

Both L2CAP connections disconnect successfully.

L2CAP/LE/CID/BV-02-C [Receiving SCID over BR/EDR and LE]

- Test Purpose

Tests that the L2CAP entity can receive the same SCID in L2CAP connect requests on both the BR/EDR and LE links.

- Reference

[12] 2.1

- Initial Condition

- An ACL-U logical link exists between the IUT and Lower Tester.
- An LE-U logical link exists between the IUT and Lower Tester.
- The IUT has made known to the Lower Tester via TSPX_psm or TSPX_spsm IXIT values, or SDP and GATT, available PSMs and SPSMs on the IUT.
- The Lower Tester has the same public Bluetooth address on the BR/EDR and LE physical transports.



- Test Procedure
 1. The Upper Tester commands the IUT to accept L2CAP connections on both BR/EDR and LE transports
 2. The Lower Tester issues an L2CAP Connection Request, using any allowable dynamically allocated CID in the range 0x0040–0x007F for the SCID, over the ACL-U logical link, to a known PSM on the IUT.
 3. The IUT sends an L2CAP Connection Response, accepting the SCID proposed by the Lower Tester and using any allowable dynamically allocated CID in the range 0x0040–0x007F for the DCID, to complete the L2CAP connection.
 4. The Lower Tester issues an L2CAP LE Credit Based Connection Request over the LE-U logical link to a known SPSM on the IUT, using the same CID used in Step 2 for the SCID.
 5. The IUT sends an LE Credit Based Connection Response, accepting the SCID proposed by the Lower Tester and using any allowable dynamically allocated CID in the range 0x0040–0x007F for the DCID, to complete the L2CAP connection.
 6. The Upper Tester commands the IUT to transfer data, of different content, over both L2CAP connections.
 7. The Lower Tester issues an L2CAP Disconnection Request over the ACL-U logical link.
 8. The Lower Tester issues an L2CAP Disconnection Request over the LE-U logical link.

- Expected Outcome

Pass verdict

Both L2CAP connections complete successfully.

Correct data for each channel is transferred successfully over both connections.

Both L2CAP connections disconnect successfully.

L2CAP/LE/CID/BV-03-C [Receiving same DCID over BR/EDR and LE]

- Test Purpose

Tests that the L2CAP entity can receive the same DCID in L2CAP connect responses on both the BR/EDR and LE links, when operating in Enhanced Credit Based Flow Control Mode.
- Reference

[13] 2.1
- Initial Condition
 - An ACL-U logical link exists between the IUT and the Lower Tester.
 - An LE-U logical link exists between the IUT and the Lower Tester.
 - The IUT has determined from the TSPX_psm or TSPX_spsm IXIT values, or SDP and GATT, available PSMs and SPSMs on the Lower Tester.
 - The Lower Tester has the same public Bluetooth address on the BR/EDR and LE physical transports.
- Test Procedure

Same as for [L2CAP/LE/CID/BV-01-C \[Receiving DCID over BR/EDR and LE\]](#), with the remark that the IUT and the Lower Tester uses an Enhanced Credit Based Flow Control channel SPSM as declared via IXIT.



- Expected Outcome

Pass verdict

Both L2CAP connections complete successfully.

Correct data for each channel is transferred successfully over both connections.

Both L2CAP connections disconnect successfully.

L2CAP/LE/CID/BV-04-C [Receiving same SCID over BR/EDR and LE]

- Test Purpose

Tests that the L2CAP entity can receive the same SCID in L2CAP connect responses on both the BR/EDR and LE links, when operating in Enhanced Credit Based Flow Control Mode.

- Reference

[13] 2.1

- Initial Condition

- An ACL-U logical link exists between the IUT and the Lower Tester.
- An LE-U logical link exists between the IUT and the Lower Tester.
- The IUT has determined from the TSPX_psm or TSPX_spsm IXIT values, or SDP and GATT, available PSMs and SPSMs on the Lower Tester.
- The Lower Tester has the same public Bluetooth address on the BR/EDR and LE physical transports.

- Test Procedure

Same as for [L2CAP/LE/CID/BV-02-C \[Receiving SCID over BR/EDR and LE\]](#), with the remark that the IUT and the Lower Tester uses an Enhanced Credit Based Flow Control channel SPSM as declared via the TSPX_spsm IXIT value.

- Expected Outcome

Pass verdict

Both L2CAP connections complete successfully.

Correct data for each channel is transferred successfully over both connections.

Both L2CAP connections disconnect successfully.

4.8.1 Ignore Unsupported CIDs

- Test Purpose

Tests that the L2CAP entity ignores unsupported CIDs in a logical link.

- Reference

[13] 2.1

- Initial Condition

- A logical link as specified in [Table 4.27](#) exists between the IUT and the Lower Tester.
- The Upper Tester can command the IUT to send data.

- Test Case Configuration

Test Case ID	Logical Link	PDU CIDs
L2CAP/COS/CID/BI-01-C [Ignore Unsupported CIDs, ACL]	ACL	0x0004, 0x0005, 0x0006, 0x0008, 0x003E
L2CAP/LE/CID/BI-01-C [Ignore Unsupported CIDs, LE]	LE-U	0x0001, 0x0002, 0x0003, 0x0007, 0x0019, 0x003F, 0x0100, 0xFFFF

Table 4.27: Ignore Unsupported CIDs test cases

- Test Procedure

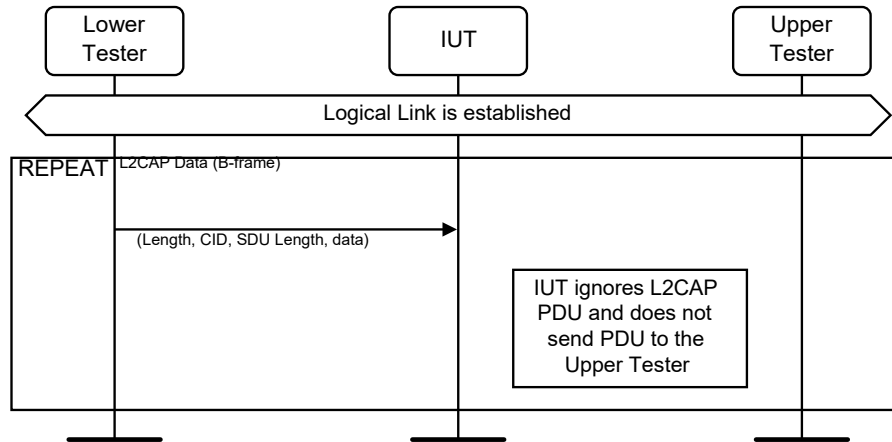

Figure 4.184: Ignore Unsupported CIDs MSC

Repeat Steps 1 and 2 for each PDU CID in Table 4.27.

- The Lower Tester sends an L2CAP Data (B-frame) PDU on the established logical link with the Channel ID of the PDU as specified in Table 4.27.
- The IUT does not send the L2CAP data to the Upper Tester.

- Expected Outcome

Pass verdict

In Step 2, the IUT ignores the L2CAP Data (B-frame) PDU from Step 1 and does not send the data to the Upper Tester.

L2CAP/CLS/CID/BV-01-C [Ignore Unsupported CIDs, APB]

- Test Purpose

Tests that the L2CAP entity ignores unsupported CIDs in a BR/EDR APB logical link.

- Reference

[13] 2.1

- Initial Condition

- An ACL connection exists between the Lower Tester and the IUT.

- Test Procedure

The Lower Tester requests Extended Features Mask using an L2CAP Information Request. The Lower Tester then transmits a G-frame over the air to the IUT.

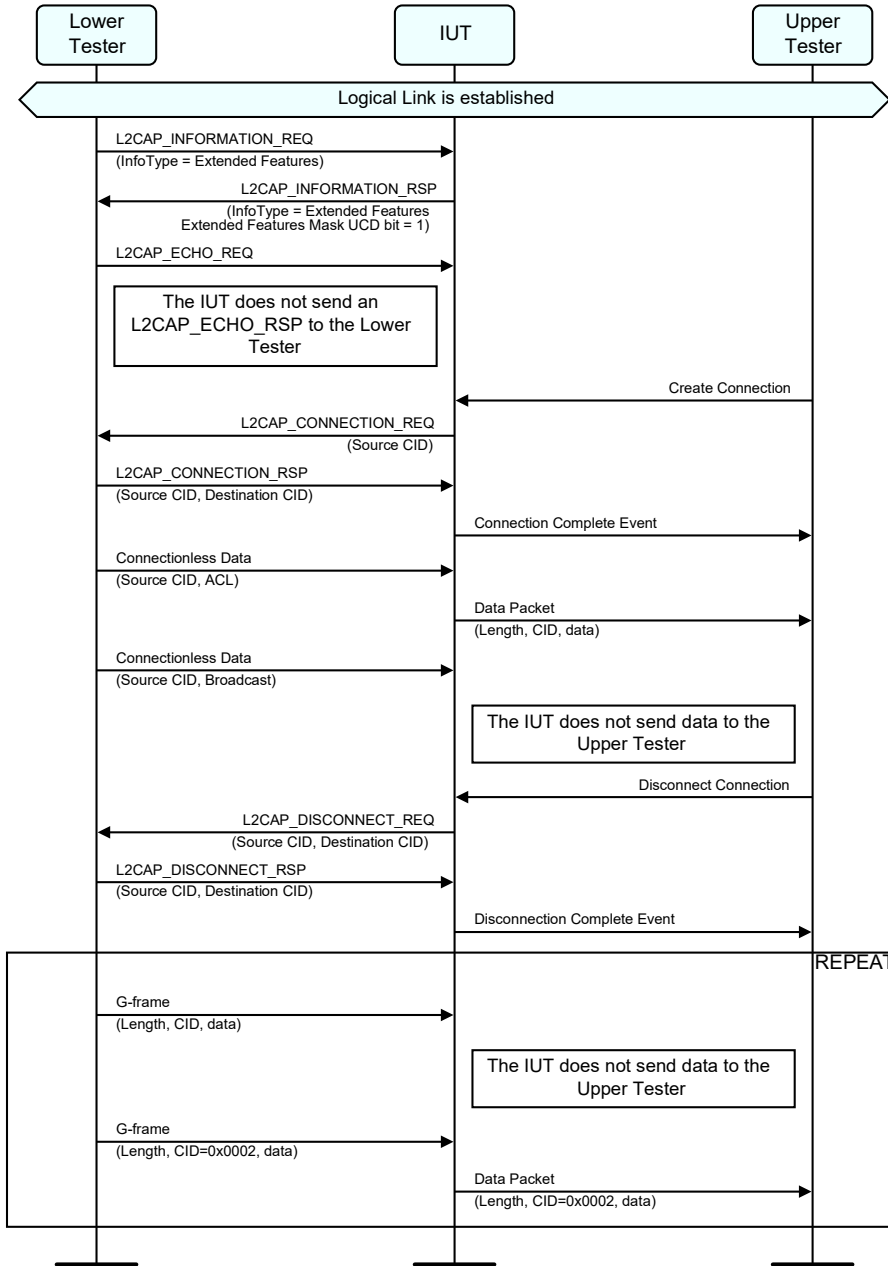

Figure 4.185: L2CAP/CLS/CID/BV-01-C [Ignore Unsupported CIDs, APB] MSC

1. The Lower Tester sends an L2CAP Info Request to the IUT with InfoType set to ExtendedFeatures.
2. The IUT sends an L2CAP Info Response to the IUT with InfoType set to ExtendedFeatures and the Extended Features Mask UCD bit set to 1.
3. The Lower Tester sends an L2CAP_ECHO_REQ to the IUT on CID 0x0001 via Active Broadcast.
4. The IUT does not send an L2CAP_ECHO_RSP to the Lower Tester.
5. The Upper Tester commands the IUT to create a dynamic L2CAP channel.
6. The IUT sends an L2CAP_CONNECTION_REQ to the Lower Tester with Source CID set to a dynamic CID.

7. The Lower Tester sends a successful L2CAP_CONNECTION_RSP with Source CID Set to the CID received in Step 6 and a Destination CID.
8. The IUT sends a successful Connection_Complete event to the Upper Tester.
9. The Lower Tester sends a data packet to the IUT on the Source CID from Step 6 over the ACL connection.
10. The IUT sends the data received in Step 9 to the Upper Tester.
11. The Lower Tester sends a data packet to the IUT on the Source CID channel received from Step 6 over Active Broadcast.
12. The IUT does not send the packet received in Step 11 to the Upper Tester.
13. The Upper Tester commands the IUT to disconnect the channel created in Step 6.
14. The IUT sends an L2CAP_DISCONNECTION_REQ to the IUT to disconnect the connection created in Step 6.
15. The Lower Tester sends a successful L2CAP_DISCONNECTION_RSP to the IUT with Destination CID and Source CID set to the values received in Step 14.
16. The IUT sends a disconnect event to the Upper Tester.
17. Repeat Steps 18–21 for CID values 0x0001, 0x0003, 0x00FF, 0xFFFF, and 2 random invalid CIDs from 0x0004–0x00FE.
18. The Lower Tester sends a connectionless G-frame via Active Broadcast on the CID from Step 17 to the IUT.
19. The IUT does not send a data packet to the Upper Tester.
20. The Lower Tester sends a connectionless G-frame via Active Broadcast on the CID set to 0x0002 to the IUT.
21. The IUT sends a data packet to the Upper Tester.

- Expected Outcome

Pass verdict

- In Step 4, the IUT does not send an L2CAP_ECHO_RSP to the Lower Tester.
- In Step 10, the IUT sends a data packet to the Upper Tester.
- In Step 12, the IUT does not send a data packet to the Upper Tester.
- In Step 19, the IUT does not send a data packet to the Upper Tester.
- In Step 21, the IUT sends a data packet to the Upper Tester.

4.9 Credit Based Flow Control Mode

4.9.1 Enhanced Credit Based Flow Control Mode

4.9.1.1 L2CAP Credit Based Connection Request – Legacy Peer

- Test Purpose

Verify that an IUT sending an L2CAP Credit Based Connection Request to a legacy peer and receiving an L2CAP Command Reject does not establish any channel.

- Reference

[13] 4.25

- Initial Condition

- An SPSM for the Enhanced Credit Based Flow Control channel is declared via the TSPX_spsm IXIT value.
- The signaling channel specified in [Table 4.28](#) is used.



- Test Case Configuration

Test Case ID	Signaling Channel
L2CAP/ECFC/BV-01-C [L2CAP Credit Based Connection Request – Legacy Peer, LE]	0x0005
L2CAP/ECFC/BV-45-C [L2CAP Credit Based Connection Request – Legacy Peer, BR/EDR]	0x0001

Table 4.28: L2CAP Credit Based Connection Request – Legacy Peer test cases

- Test Procedure

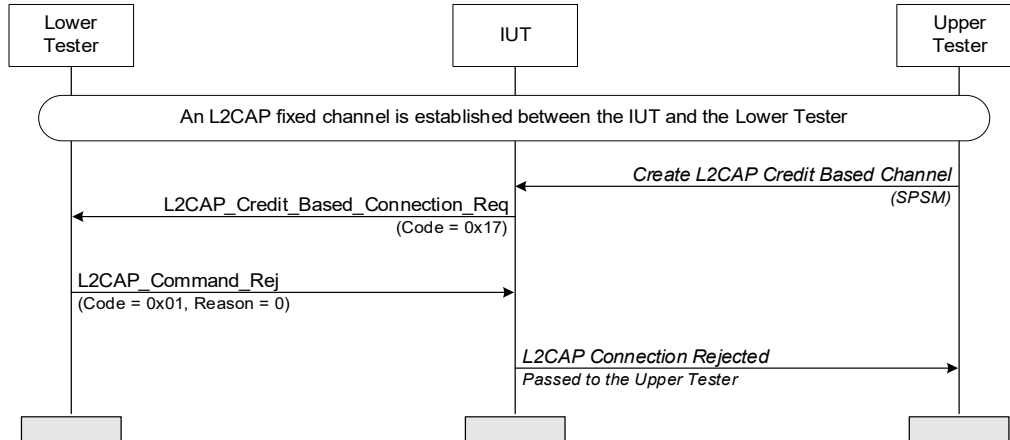

Figure 4.186: L2CAP Credit Based Connection Request – Legacy Peer MSC

1. The IUT sends an L2CAP Credit Based Connection Request (Code = 0x17) on the SPSM declared via IXIT.
2. The Lower Tester responds with an L2CAP Command Reject (Code = 0x01).

- Expected Outcome

Pass verdict

After receiving the Command Reject from the Lower Tester, the IUT informs the Upper Tester.

4.9.1.2 L2CAP Credit Based Connection Request on Supported PSM

- Test Purpose

Verify that an IUT sending an L2CAP Credit Based Connection Request to a peer establishes all the channels upon receiving the L2CAP Credit Based Connection Response.

- Reference

[13] 4.25

- Initial Condition

- The signaling channel specified in Table 4.29 is used.
- An SPSM for the Enhanced Credit Based Flow Control channel is declared via the TSPX_spsm IXIT value.
- The Upper Tester can command the IUT to create a credit based channel on the SPSM declared via the TSPX_spsm IXIT value and send credits.

- Test Case Configuration

Test Case ID	Signaling Channel
L2CAP/ECFC/BV-02-C [L2CAP Credit Based Connection Request on Supported PSM, LE]	0x0005
L2CAP/ECFC/BV-46-C [L2CAP Credit Based Connection Request on Supported PSM, BR/EDR]	0x0001

Table 4.29: L2CAP Credit Based Connection Request on Supported PSM test cases

- Test Procedure

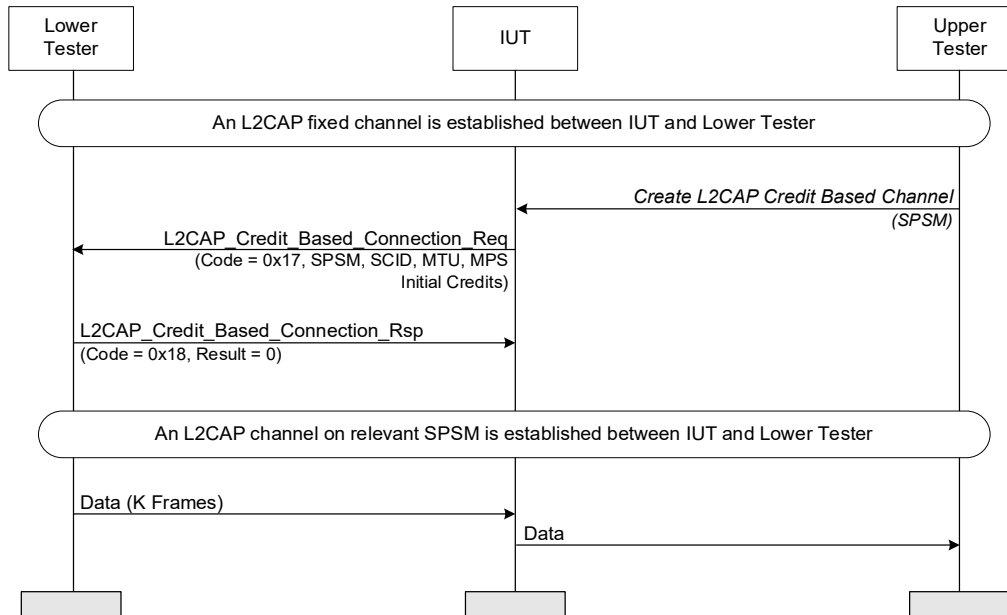

Figure 4.187: L2CAP Credit Based Connection Request on Supported PSM MSC

1. The IUT sends an L2CAP Credit Based Connection Request (Code = 0x17) on the SPSM declared via IXIT.
2. The Lower Tester responds with an L2CAP Credit Based Connection Response (Code = 0x18) packet.
3. The Lower Tester sends data on the established channel.

- Expected Outcome

Pass verdict

The IUT receives the data sent by the Lower Tester on the correct channel. The data is passed to the Upper Tester.

4.9.1.3 L2CAP Credit Based Connection Response on Supported PSM

- Test Purpose

Verify that an IUT receiving a valid L2CAP Credit Based Connection Request from a peer sends an L2CAP Credit Based Connection Response and establishes the channels.

- Reference

[13] 4.26

- Initial Condition
 - The signaling channel specified in Table 4.30 is used.
 - An SPSM for the Enhanced Credit Based Flow Control channel is declared via the TSPX_spsm IXIT value.
 - The Upper Tester can command the IUT to send data and credits.

Test Case Configuration

Test Case ID	Signaling Channel
L2CAP/ECFC/BV-03-C [L2CAP Credit Based Connection Response on Supported PSM, LE]	0x0005
L2CAP/ECFC/BV-47-C [L2CAP Credit Based Connection Response on Supported PSM, BR/EDR]	0x0001

Table 4.30: L2CAP Credit Based Connection Response on Supported PSM test cases

Test Procedure

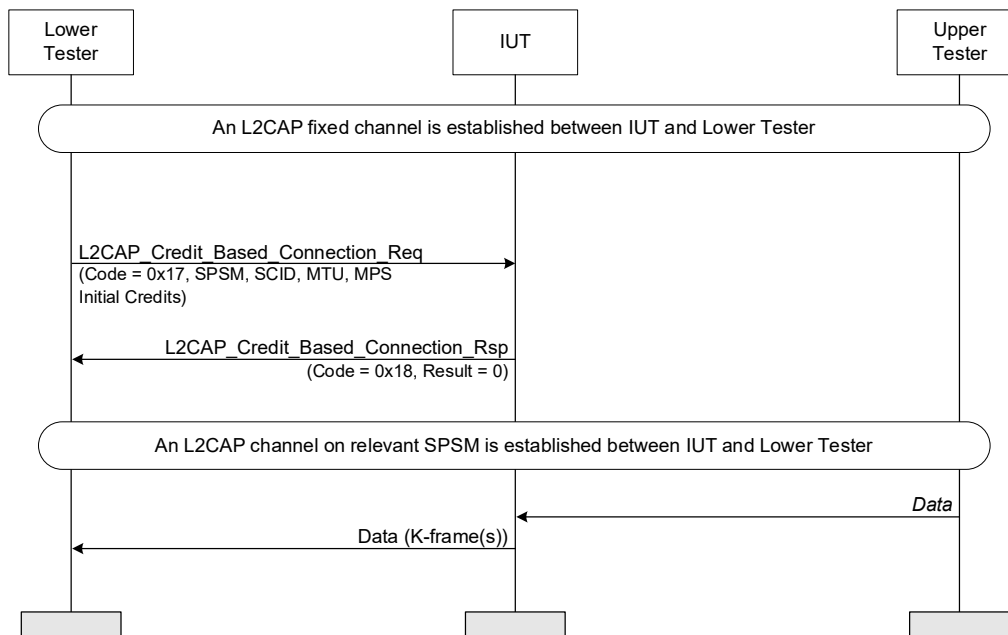

Figure 4.188: L2CAP Credit Based Connection Response on Supported PSM MSC

- The Lower Tester sends an L2CAP Credit Based Connection Request (Code = 0x17) to the IUT on the SPSM specified in the initial conditions.
- The IUT responds with an L2CAP Credit Based Connection Response (Code = 0x18).
- The Upper Tester commands the IUT to send data on the data channel.

Expected Outcome

Pass verdict

The IUT sends one or more correctly formatted K-frames on the correct channel to the Lower Tester.
 The data sent by the IUT to the Lower Tester matches the data sent by the Upper Tester to the IUT.

4.9.1.4 L2CAP Credit Based Connection Request on an Unsupported PSM

- Test Purpose

Verify that an IUT sending an L2CAP Credit Based Connection Request on an unsupported PSM does not establish any channel upon receiving an L2CAP Credit Based Connection Response refusing the connection.

- Reference

[13] 4.25

- Initial Condition

- The signaling channel specified in Table 4.31 is used.
- An SPSM for the Enhanced Credit Based Flow Control channel is declared via the TSPX_spsm IXIT value.
- The Upper Tester can command the IUT to create a credit based channel on the SPSM declared via the TSPX_spsm IXIT value.

- Test Case Configuration

Test Case ID	Signaling Channel
L2CAP/ECFC/BV-04-C [L2CAP Credit Based Connection Request on an Unsupported PSM, LE]	0x0005
L2CAP/ECFC/BV-48-C [L2CAP Credit Based Connection Request on an Unsupported PSM, BR/EDR]	0x0001

Table 4.31: L2CAP Credit Based Connection Request on an Unsupported PSM test cases

- Test Procedure

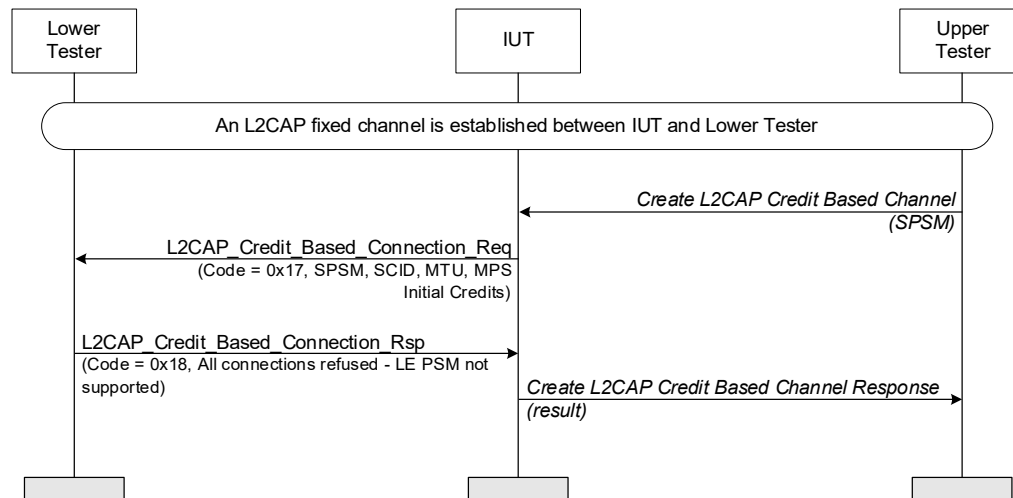

Figure 4.189: L2CAP Credit Based Connection Request on an Unsupported PSM MSC

1. The IUT sends an L2CAP Credit Based Connection Request (Code = 0x17) packet on the SPSM specified in the initial conditions which is not supported by the Lower Tester.
2. The Lower Tester sends an L2CAP Credit Based Connection Response (Code = 0x18) with result "0x0002 – All connections refused - LE PSM not supported".

- Expected Outcome

Pass verdict

The IUT receives an L2CAP Credit Based Connection Response packet with result “0x0002 – All connections refused – LE PSM not supported” from the Lower Tester. This is indicated to the Upper Tester.

4.9.1.5 Credit Exchange – Receiving Incremental Credits

- Test Purpose

Verify that the IUT handles flow control correctly, by handling the L2CAP Flow Control Credit Indication sent by the peer.

- Reference

[13] 4.24

- Initial Condition

- The signaling channel specified in Table 4.32 is used.
- An SPSM for the Enhanced Credit Based Flow Control channel is declared via the TSPX_spsm IXIT value.
- An LE or BR/EDR Data Channel is established on the SPSM.
- The role of the IUT is indicated in the TSPX_iut_role_initiator IXIT value.
- The Upper Tester can command the IUT to send data.

- Test Case Configuration

Test Case ID	Signaling Channel
L2CAP/ECFC/BV-06-C [Credit Exchange – Receiving Incremental Credits, LE]	0x0005
L2CAP/ECFC/BV-49-C [Credit Exchange – Receiving Incremental Credits, BR/EDR]	0x0001

Table 4.32: Credit Exchange – Receiving Incremental Credits test cases

- Test Procedure

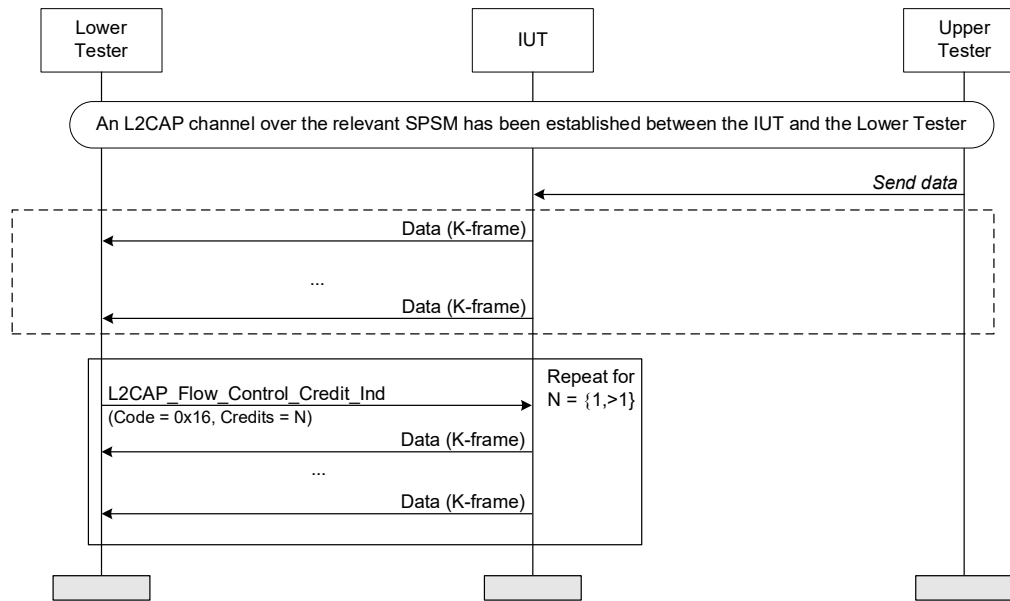

Figure 4.190: Credit Exchange – Receiving Incremental Credits MSC

- The Upper Tester requests the IUT to send data packets to the Lower Tester.
- The IUT sends K-frames containing data to the Lower Tester, as many as the initial credit count.
- The Lower Tester sends an L2CAP Flow Control Credit Indication (Code = 0x16) packet with Credit Value N to the IUT on the CID.
- The IUT sends K-frames containing data to the Lower Tester.
- After receiving N K-frames from the IUT and ensuring that no more K-frames are received, the Lower Tester sends a new L2CAP Flow Control Credit Indication packet with a Credits Value of N on the CID. The IUT sends N K-frames containing data to the Lower Tester.
- The Test Procedure Steps 3–5 are repeated with credit increment $N = \{1, >1\}$ without disconnecting the channel.

- Expected Outcome

Pass verdict

After receiving N credits, the IUT sends N correctly formatted K-frames containing data to the Lower Tester.

The IUT stops sending K-frames to the Lower Tester when the credit count reaches zero.

4.9.1.6 Credit Exchange – Sending Credits

- Test Purpose

Verify that the IUT sends Flow Control Credit Indication to the peer.

- Reference

[13] 4.24

- Initial Condition

- The signaling channel specified in Table 4.33 is used.
- An SPSM for the Enhanced Credit Based Flow Control channel is declared via the TSPX_spsm IXIT value.

- An LE or BR/EDR Data Channel is established on the SPSM declared via the TSPX_spsm IXIT value.
- The role of the IUT is indicated in the TSPX_iut_role_initiator IXIT value.
- The Upper Tester can command the IUT to send credits.

• Test Case Configuration

Test Case ID	Signaling Channel
L2CAP/ECFC/BV-07-C [Credit Exchange – Sending Credits, LE]	0x0005
L2CAP/ECFC/BV-50-C [Credit Exchange – Sending Credits, BR/EDR]	0x0001

Table 4.33: Credit Exchange – Sending Credits test cases

• Test Procedure

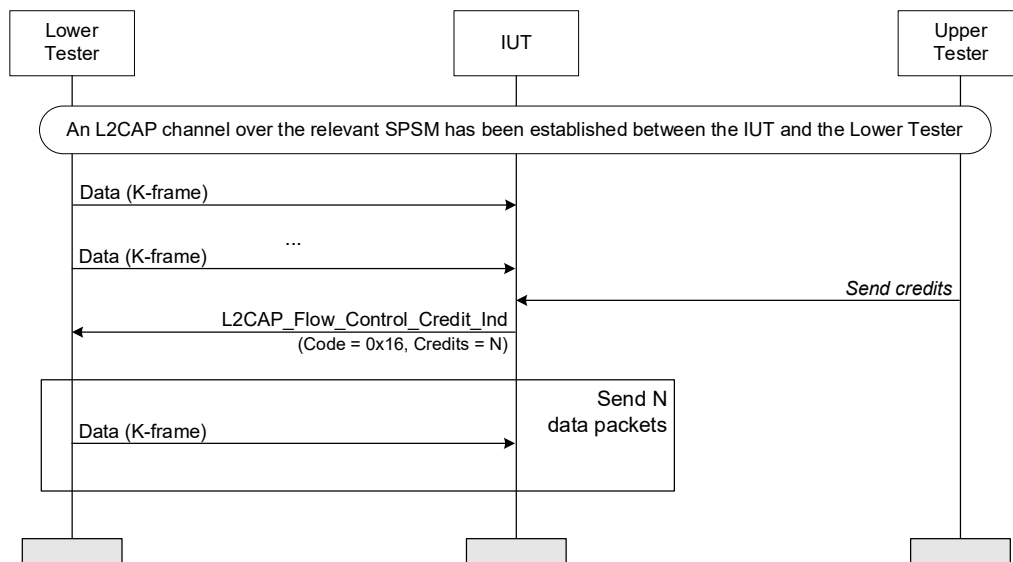

Figure 4.191: Credit Exchange – Sending Credits MSC

1. The Lower Tester sends data packets to the IUT until it gets credits returned, i.e., the data to send could consume more than the current credits available on the channel.
2. When the Lower Tester remains without credits, the Upper Tester commands the IUT to send N credits to the Lower Tester.
3. The IUT sends an L2CAP Flow Control Credit Indication (Code = 0x16) packet containing Credits = N to the Lower Tester.
4. The Lower Tester starts sending data packets to the IUT and sends N packets.

• Expected Outcome

Pass verdict

The IUT sends a correctly formatted L2CAP Flow Control Credit Indication (Code = 0x16) packet to the Lower Tester at least once doing the data transfer.

4.9.1.7 Credit Exchange – Zero Credits and Exceed Maximum Credits

- Test Purpose

Verify that the IUT ignores an L2CAP Flow Control Credit Indication packet with credit value set to zero and disconnects the Data Channel created through Enhanced Credit Based Flow Control Mode when the credit count exceeds 65535.

- Reference

[13] 4.24

- Initial Condition

- The signaling channel specified in Table 4.34 is used.
- An SPSM for the Enhanced Credit Based Flow Control channel is declared via the TSPX_spsm IXIT value.
- An LE or BR/EDR Data Channel is established on the TSPX_spsm IXIT value.
- The role of the IUT is indicated in the TSPX_iut_role_initiator IXIT value.
- The initial credit on the LE or BR/EDR Data Channel set by the Lower Tester is more than 1.

- Test Case Configuration

Test Case ID	Signaling Channel
L2CAP/ECFC/BI-01-C [Credit Exchange – Zero Credits and Exceed Maximum Credits, LE]	0x0005
L2CAP/ECFC/BI-10-C [Credit Exchange – Zero Credits and Exceed Maximum Credits, BR/EDR]	0x0001

Table 4.34: Credit Exchange – Zero Credits and Exceed Maximum Credits test cases

- Test Procedure

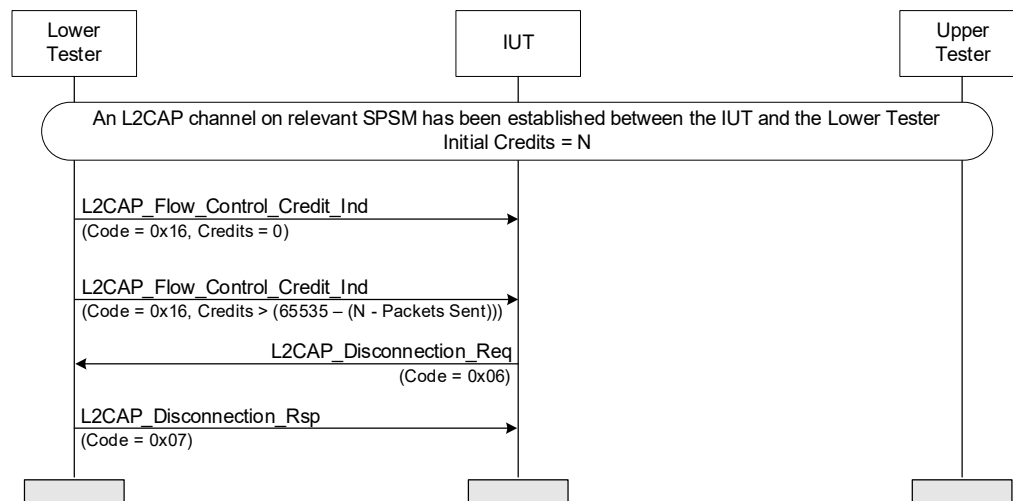

Figure 4.192: Credit Exchange – Zero Credits and Exceed Maximum Credits MSC

1. The Lower Tester sends an L2CAP Flow Control Credit Indication (Code = 0x16) packet to the IUT, with Credits = 0.
2. The IUT silently discards the packet and does not modify its credit count.

3. The Lower Tester sends an L2CAP Flow Control Credit Indication packet containing a credit so large that it together with the remaining credits on the IUT exceeds 65535.
4. The IUT sends an L2CAP Disconnection Request (Code = 0x06) packet to the Lower Tester, for the CID with exceeding credits.
5. The Lower Tester sends an L2CAP Disconnection Response (Code = 0x07) to the IUT.

- Expected Outcome

Pass verdict

The IUT ignores the L2CAP Flow Control Credit Indication packet with credit value set to zero, in Step 1.

Upon receiving a credit overflow, the IUT disconnects the Data Channel.

4.9.1.8 Credit Exchange – No Credits

- Test Purpose

Verify that the IUT either returns credits or disconnects the Data Channel created through Enhanced Credit Based Flow Control Mode when receiving a K-frame from the peer device that has the credit count of 0 (zero).

- Reference

[13] 4.24

- Initial Condition

- The signaling channel specified in [Table 4.35](#) is used.
- An SPSM for the Enhanced Credit Based Flow Control channel is declared via the TSPX_spsm IXIT value.
- An LE or BR/EDR Data Channel is established on the SPSM declared via the TSPX_spsm IXIT value.
- The role of the IUT is indicated in the TSPX_iut_role_initiator IXIT value.
- The initial credit on the LE Data Channel sent to the Lower Tester in a signaling packet is N. If the IUT allows the number of credits to be chosen, then N should be the smallest supported number greater than 1.

- Test Case Configuration

Test Case ID	Signaling Channel
L2CAP/ECFC/BI-02-C [Credit Exchange – No Credits, LE]	0x0005
L2CAP/ECFC/BI-11-C [Credit Exchange – No Credits, BR/EDR]	0x0001

Table 4.35: Credit Exchange – No Credits test cases

- Test Procedure

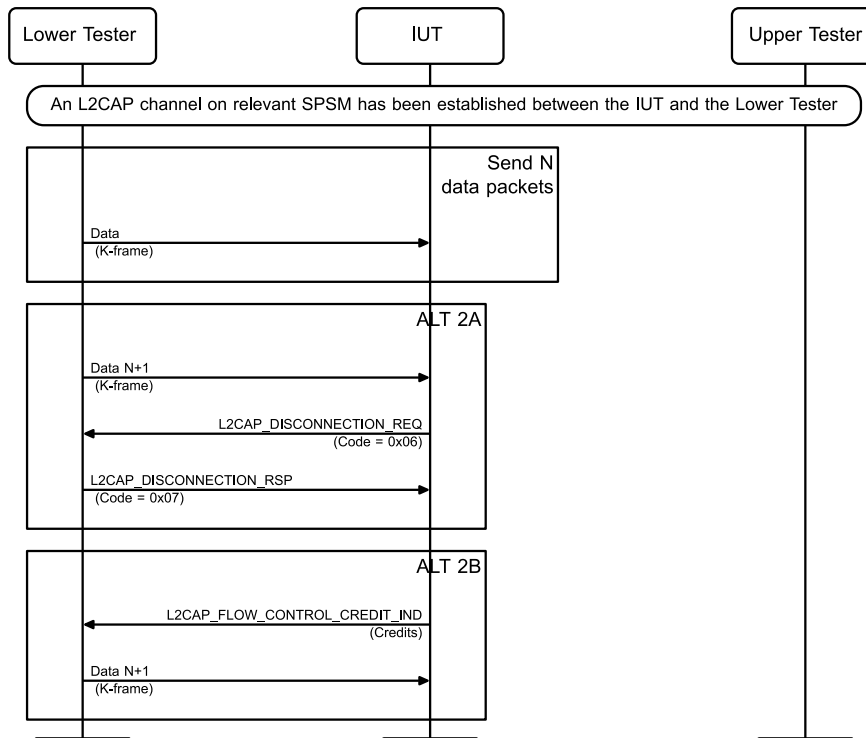

Figure 4.193: Credit Exchange – No Credits MSC

- The Lower Tester starts sending data packets to the IUT and sends N+1 packets.
- After the IUT receives the Nth packet, execute either alternative 2A or 2B.

Alternative 2A (The IUT does not return credits to the Lower Tester):

- 2A.1 The IUT receives the N+1st packet, discards the packet, and sends an L2CAP_DISCONNECTION_REQ packet (Code = 0x06) to the Lower Tester.
- 2A.2 The Lower Tester sends an L2CAP_DISCONNECTION_RSP packet (Code = 0x07) to the IUT.

Alternative 2B (The IUT returns credits to the Lower Tester):

- 2B.1 The IUT sends an L2CAP_FLOW_CONTROL_CREDIT_IND to the Lower Tester with Credits > 0.
- 2B.2 The IUT receives the N+1st packet.

- Expected Outcome

Pass verdict

Upon receiving the N+1st packet in Step 2A.1, the IUT disconnects the Data Channel, sending an L2CAP_DISCONNECTION_REQ packet to the Lower Tester.

In Step 2B.1, the IUT returns credits to the Lower Tester.

L2CAP/ECFC/BV-11-C [Security – Insufficient Authentication – Responder, LE]

- Test Purpose

Verify that an IUT refuses to create any connection upon reception of an L2CAP Credit Based Connection Request which fails to satisfy authentication requirements.

- Reference

[13] 4.25

- Initial Condition

- An LE ACL connection is established between the IUT and the Lower Tester.
- An SPSM for the Enhanced Credit Based Flow Control channel is declared via the TSPX_spsm IXIT value.
- An authentication requirement exists for the SPSM channel declared via the TSPX_spsm IXIT value.
- Either no LTK exists or an Unauthenticated LTK exists between the IUT and the Lower Tester.

- Test Procedure

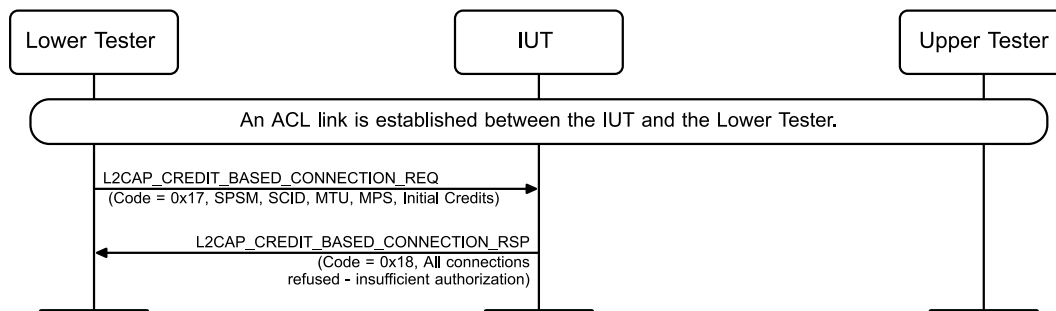

Figure 4.194: Security – Insufficient Authentication – Responder, LE MSC

1. The Lower Tester sends an L2CAP Credit Based Connection Request (Code = 0x17) on the SPSM specified in the initial conditions which requires authentication.
2. The IUT detects either there was no LTK or LTK with insufficient security level and sends an L2CAP Credit Based Connection Response (Code = 0x18), rejecting the connection request with error code “All connections refused – insufficient authentication”.

- Expected Outcome

Pass verdict

Upon reception of an L2CAP Credit Based Connection Request from the Lower Tester which fails to satisfy the authentication requirements, the IUT sends a correctly formatted L2CAP Credit Based Connection Response with Result 0x0005 (“All connections refused – insufficient authentication”) to the Lower Tester.

4.9.1.9 Security – Insufficient Encryption Key Size – Initiator

- Test Purpose

Verify that the IUT does not establish any channel upon receipt of an L2CAP Credit Based Connection Response indicating the connections were refused with Result 0x0007 (“All connections refused – insufficient encryption key size”).

- Reference

[13] 4.25

- Initial Condition

- The signaling channel specified in Table 4.36 is used.
- An SPSM for the Enhanced Credit Based Flow Control channel is declared via the TSPX_spsm IXIT value.
- The Upper Tester can command the IUT to create a credit based channel on the SPSM declared via the TSPX_spsm IXIT value.
- Either an Unauthenticated or Authenticated LTK exists between the IUT and the Lower Tester.

- Test Case Configuration

Test Case ID	Signaling Channel
L2CAP/ECFC/BV-14-C [Security – Insufficient Encryption Key Size – Initiator, LE]	0x0005
L2CAP/ECFC/BV-52-C [Security – Insufficient Encryption Key Size – Initiator, BR/EDR]	0x0001

Table 4.36: Security – Insufficient Encryption Key Size – Initiator test cases

- Test Procedure

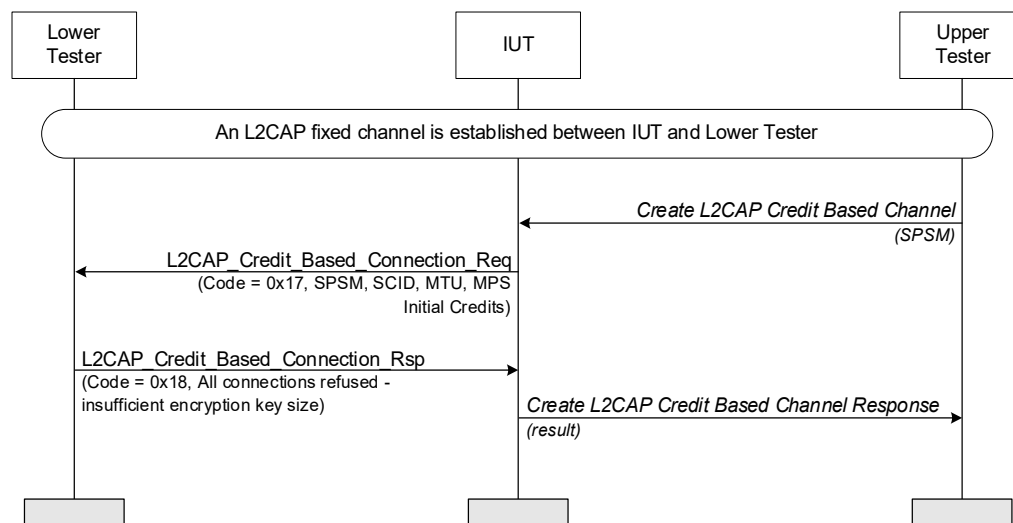

Figure 4.195: Security – Insufficient Encryption Key Size – Initiator MSC

1. The Upper Tester commands the IUT to send a connection request.
2. The IUT sends an L2CAP Credit Based Connection Request (Code = 0x17).
3. The Lower Tester sends an L2CAP Credit Based Connection Response (Code = 0x18) with result 0x0007 (“All connections refused - insufficient encryption key size”), refusing the connection request.

- Expected Outcome

Pass verdict

The IUT informs the Upper Tester about the rejection.



4.9.1.10 L2CAP Credit Based Connection Response – refused due to insufficient resources

- Test Purpose

Verify that an IUT receiving an L2CAP Credit Based Connection Request for several channels refuses the connections for which it doesn't have sufficient resources with result 0x0004 ("Some connections refused – insufficient resources available").

- Reference

[13] 4.25

- Initial Condition

- An SPSM for the Enhanced Credit Based Flow Control channel is declared via the TSPX_spsm IXIT value.
- The maximum number of L2CAP channels for the SPSM is declared via the TSPX_iut_supported_max_channels IXIT value that the IUT supports.
- The signaling channel specified in Table 4.37 is used.
- A number of LE or BR/EDR Data Channels are established on the SPSM declared via IXIT, such that this number is less than the maximum number previously stated in the TSPX_spsm IXIT value, with at most 4.

- Test Case Configuration

Test Case ID	Signaling Channel
L2CAP/ECFC/BV-17-C [L2CAP Credit Based Connection Response – refused due to insufficient resources, LE]	0x0005
L2CAP/ECFC/BV-53-C [L2CAP Credit Based Connection Response – refused due to insufficient resources, BR/EDR]	0x0001

Table 4.37: L2CAP Credit Based Connection Response – refused due to insufficient resources test cases

- Test Procedure

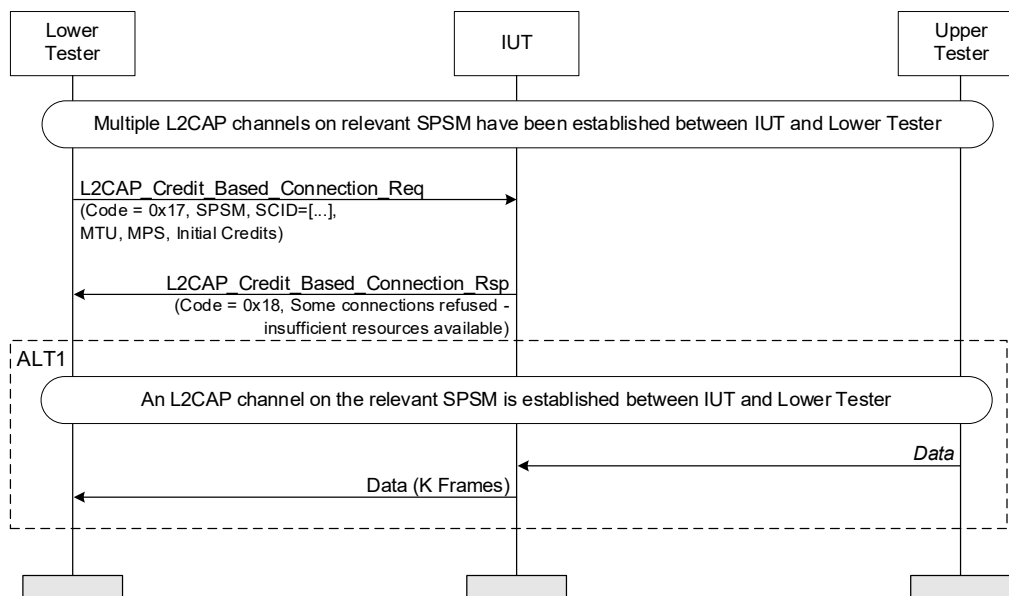

Figure 4.196: L2CAP Credit Based Connection Response – refused due to insufficient resources MSC

1. The Lower Tester sends an L2CAP Credit Based Connection Request on different CIDs than the existing ones, to reach the maximum number of channels + 1.
2. Either the IUT establishes the new channels, up to the maximum supported, and sends a correctly formatted L2CAP Credit Based Connection Response to the Lower Tester with Result 0x0004 (“Some connections refused – insufficient resources available”) as in ALT 1, or if the IUT can support the maximum number of channels, then according to ALT 2, the new L2CAP channels are established.
3. The IUT sends data on at least one of the newly created channels.

- Expected Outcome

Pass verdict

In Step 2, the IUT follows either ALT 1 or ALT 2:

ALT 1: The IUT sends a correctly formatted L2CAP Credit Based Connection Response to the Lower Tester with result 0x0004 (“Some connections refused – insufficient resources available”).

ALT 2: The IUT can establish the maximum number of channels, and the new L2CAP channels are successfully established. The IUT sends a correctly formatted L2CAP Credit Based Connection Response to the Lower Tester with result 0x0000 (“All connections successful”). The IUT sends at least one data packet on one of the newly created channels.

4.9.1.11 L2CAP Credit Based Connection Request – refused due to Invalid Source CID

- Test Purpose

Verify that an IUT sending an L2CAP Credit Based Connection Request does not establish some of the requested channels upon receiving an L2CAP Credit Based Connection Response refusing the connections with result 0x0009 (“Some connections refused – Invalid Source CID”).

- Reference

[13] 4.25

- Initial Condition

- The signaling channel specified in [Table 4.38](#) is used.
- An SPSM for the Enhanced Credit Based Flow Control channel is declared via the TSPX_spsm IXIT value.
- The Upper Tester can command the IUT to create a credit based channel on the SPSM declared via the TSPX_spsm IXIT value.

- Test Case Configuration

Test Case ID	Signaling Channel
L2CAP/ECFC/BV-18-C [L2CAP Credit Based Connection Request – refused due to Invalid Source CID, LE]	0x0005
L2CAP/ECFC/BV-54-C [L2CAP Credit Based Connection Request – refused due to Invalid Source CID, BR/EDR]	0x0001

Table 4.38: L2CAP Credit Based Connection Request – refused due to Invalid Source CID test cases

- Test Procedure

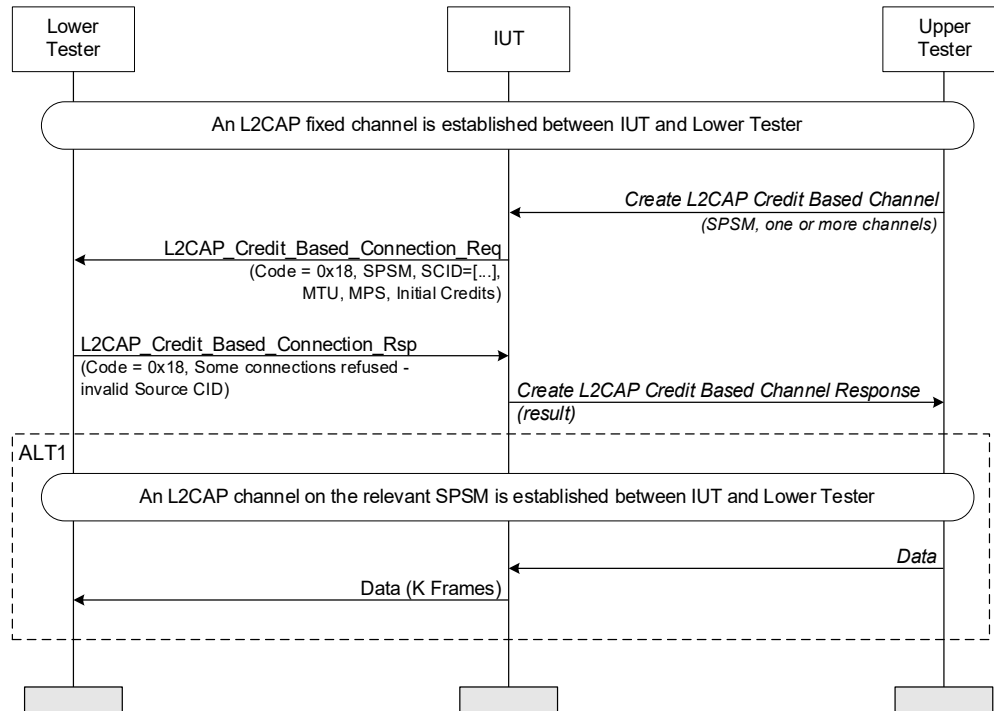

Figure 4.197: L2CAP Credit Based Connection Request – refused due to Invalid Source CID MSC

- The Upper Tester commands the IUT to send a connection request.
- The IUT sends an L2CAP Credit Based Connection Request (Code = 0x17).
- The Lower Tester sends an L2CAP Credit Based Connection Response (Code = 0x18) with result 0x0009 (“Some connections refused - invalid Source CID”), refusing the connection request.
- (ALT1) If the connection request was performed with more than one SCID and some of the channels were created, the Upper Tester commands the IUT to send data on the accepted CIDs.

- Expected Outcome

Pass verdict

The IUT informs the Upper Tester that some connections were refused.

(ALT1) The data sent by the IUT in Step 3 must be the same as that received by the Lower Tester.

The IUT does not send any data to the Lower Tester on the refused CID(s).

4.9.1.12 L2CAP Credit Based Connection Request – refused due to Source CID already allocated

- Test Purpose

Verify that an IUT sending an L2CAP Credit Based Connection Request does not establish some of the requested channels upon receiving an L2CAP Credit Based Connection Response refusing some of the connections with result 0x000A (“Some connections refused – Source CID already allocated”).

- Reference

[13] 4.25

- Initial Condition
 - The signaling channel specified in Table 4.39 is used.
 - An SPSM for the Enhanced Credit Based Flow Control channel is declared via the TSPX_spsm IXIT value.
 - The Upper Tester can command the IUT to create a credit based channel on the SPSM declared via the TSPX_spsm IXIT value.

• Test Case Configuration

Test Case ID	Signaling Channel
L2CAP/ECFC/BV-19-C [L2CAP Credit Based Connection Request – refused due to Source CID already allocated, LE]	0x0005
L2CAP/ECFC/BV-55-C [L2CAP Credit Based Connection Request – refused due to Source CID already allocated, BR/EDR]	0x0001

Table 4.39: L2CAP Credit Based Connection Request – refused due to Source CID already allocated test cases

• Test Procedure

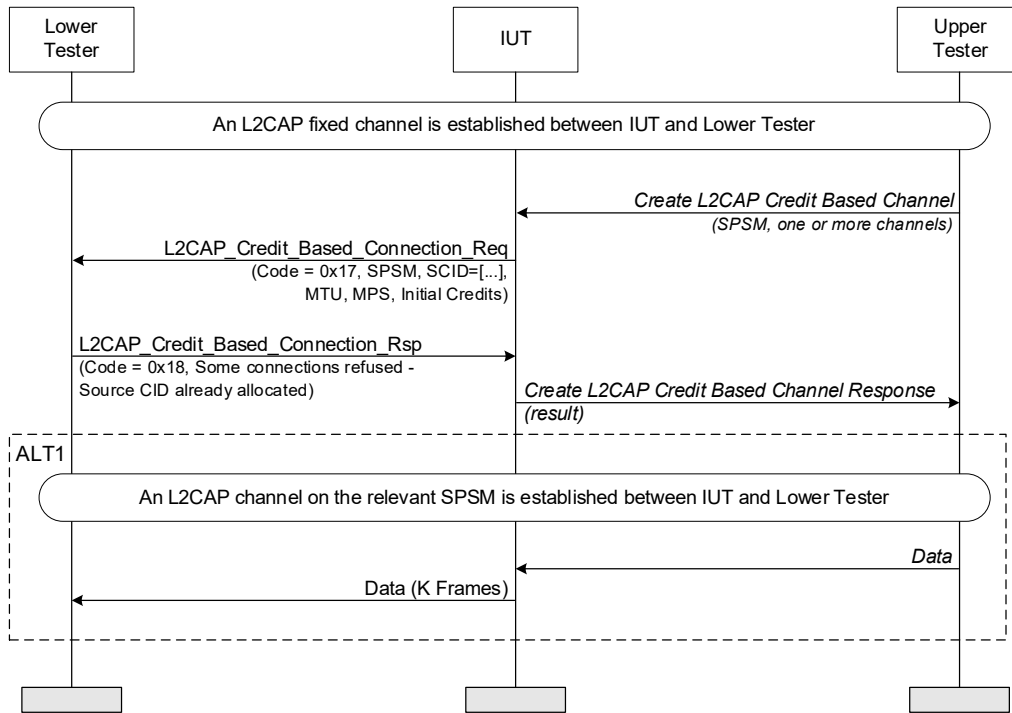

Figure 4.198: L2CAP Credit Based Connection Request – refused due to Source CID already allocated MSC

1. The Upper Tester commands the IUT to send a connection request.
2. The IUT sends an L2CAP Credit Based Connection Request (Code = 0x17).
3. The Lower Tester sends an L2CAP Credit Based Connection Response (Code = 0x18) with result 0x000A (“Some connections refused – Source CID already allocated”), refusing the connection request.
4. (ALT1) If the connection request was performed with more than one SCID and some of the channels were created, the Upper Tester commands the IUT to send data on the accepted CIDs.

- Expected Outcome

Pass verdict

The IUT informs the Upper Tester that the connection was refused.

(ALT1) The data send by the IUT in Step 3 must be the same as that received by the Lower Tester.

The IUT does not send any data to the Lower Tester on the refused CID(s).

4.9.1.13 L2CAP Credit Based Connection Response – refused due to Source CID already allocated

- Test Purpose

Verify that an IUT receiving an L2CAP Credit Based Connection Request for several channels refuses some of the connections with result 0x000A (“Some connections refused – Source CID already allocated”) if it receives a Source CID which is already in use.

- Reference

[13] 4.25

- Initial Condition

- The signaling channel specified in Table 4.40 is used.
- An SPSM for the Enhanced Credit Based Flow Control channel is declared via the TSPX_spsm IXIT value.
- One LE or BR/EDR Data channel is established on the SPSM declared via the TSPX_spsm IXIT value.

- Test Case Configuration

Test Case ID	Signaling Channel
L2CAP/ECFC/BV-20-C [L2CAP Credit Based Connection Response – refused due to Source CID already allocated, LE]	0x0005
L2CAP/ECFC/BV-56-C [L2CAP Credit Based Connection Response – refused due to Source CID already allocated, BR/EDR]	0x0001

Table 4.40: L2CAP Credit Based Connection Response – refused due to Source CID already allocated test cases

- Test Procedure

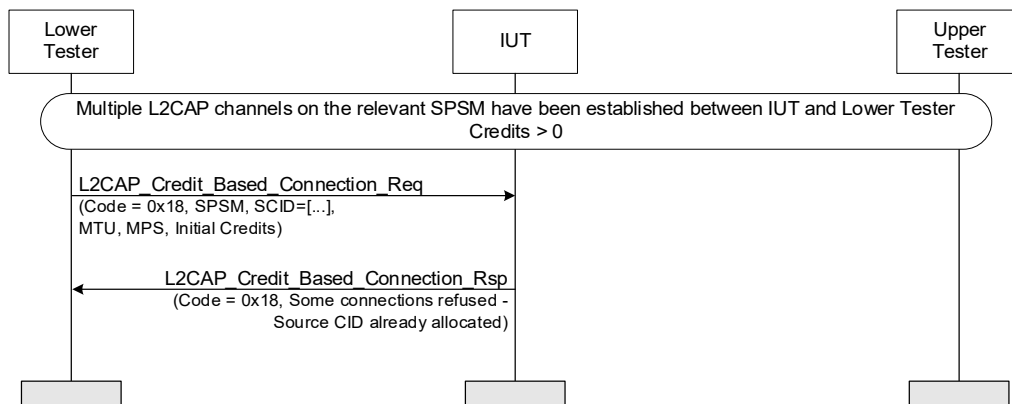

Figure 4.199: L2CAP Credit Based Connection Response – refused due to Source CID already allocated MSC



1. The Lower Tester sends an L2CAP Credit Based Connection Request (Code = 0x17) using the same CID as the previously established channel.
2. The IUT sends an L2CAP Credit Based Connection Response (Code = 0x18) to the Lower Tester with result 0x000A (“Some connections refused – Source CID already allocated”).

- Expected Outcome

Pass verdict

The IUT sends a correctly formatted L2CAP Credit Based Connection Response to the Lower Tester with result 0x000A (“Some connections refused – Source CID already allocated”).

4.9.1.14 L2CAP Credit Based Connection Request – refused due to Unacceptable Parameters

- Test Purpose

Verify that an IUT sending an L2CAP Credit Based Connection Request does not establish any channel upon receiving an L2CAP Credit Based Connection Response refusing the connections with result 0x000B (“All connections refused – unacceptable parameters”).

- Reference

[13] 4.25

- Initial Condition

- The signaling channel specified in Table 4.41 is used.
- An SPSM for the Enhanced Credit Based Flow Control channel is declared via the TSPX_spsm IXIT value.
- The Upper Tester can command the IUT to create a credit based channel on the SPSM declared via the TSPX_spsm IXIT value.

- Test Case Configuration

Test Case ID	Signaling Channel
L2CAP/ECFC/BV-21-C [L2CAP Credit Based Connection Request – refused due to Unacceptable Parameters, LE]	0x0005
L2CAP/ECFC/BV-57-C [L2CAP Credit Based Connection Request – refused due to Unacceptable Parameters, BR/EDR]	0x0001

Table 4.41: L2CAP Credit Based Connection Request – refused due to Unacceptable Parameters test cases



- Test Procedure

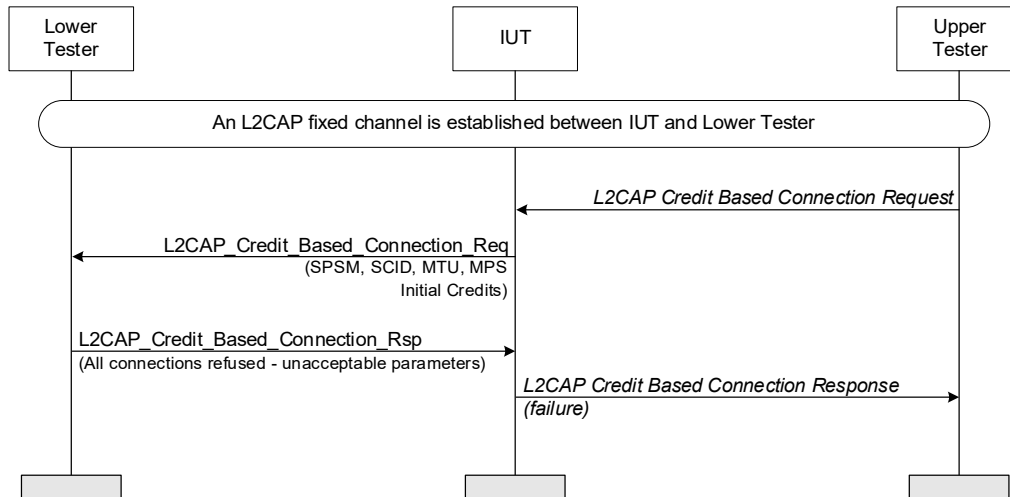

Figure 4.200: L2CAP Credit Based Connection Request – refused due to Unacceptable Parameters MSC

1. The Upper Tester commands the IUT to send a connection request.
2. The IUT sends an L2CAP Credit Based Connection Request (Code = 0x17).
3. The Lower Tester sends an L2CAP Credit Based Connection Response (Code = 0x18) with result 0x000B (“All connections refused – unacceptable parameters”), refusing the connection request.

- Expected Outcome

Pass verdict

The IUT informs the Upper Tester that the connection was refused.

4.9.1.15 Renegotiate MTU – Initiator

- Test Purpose

Verify that the IUT sending an L2CAP Credit Based Reconfigure Request can reconfigure the Maximum Transmission Unit (MTU) for the indicated channels, being able to receive larger SDUs.

- Reference

[13] 4.27

- Initial Condition

- The maximum supported MTU size is defined by the TSPX_I2ca_cbmtu_max IXIT entry.
- The minimum supported MTU size is defined by the TSPX_I2ca_cbmtu_min IXIT entry.
- The signaling channel specified in Table 4.42 is used.
- An SPSM for the Enhanced Credit Based Flow Control channel is declared via the TSPX_spsm IXIT value.

- Test Case Configuration

Test Case ID	Signaling Channel
L2CAP/ECFC/BV-22-C [Renegotiate MTU – Initiator, LE]	0x0005
L2CAP/ECFC/BV-58-C [Renegotiate MTU – Initiator, BR/EDR]	0x0001

Table 4.42: Renegotiate MTU – Initiator test cases

- Test Procedure

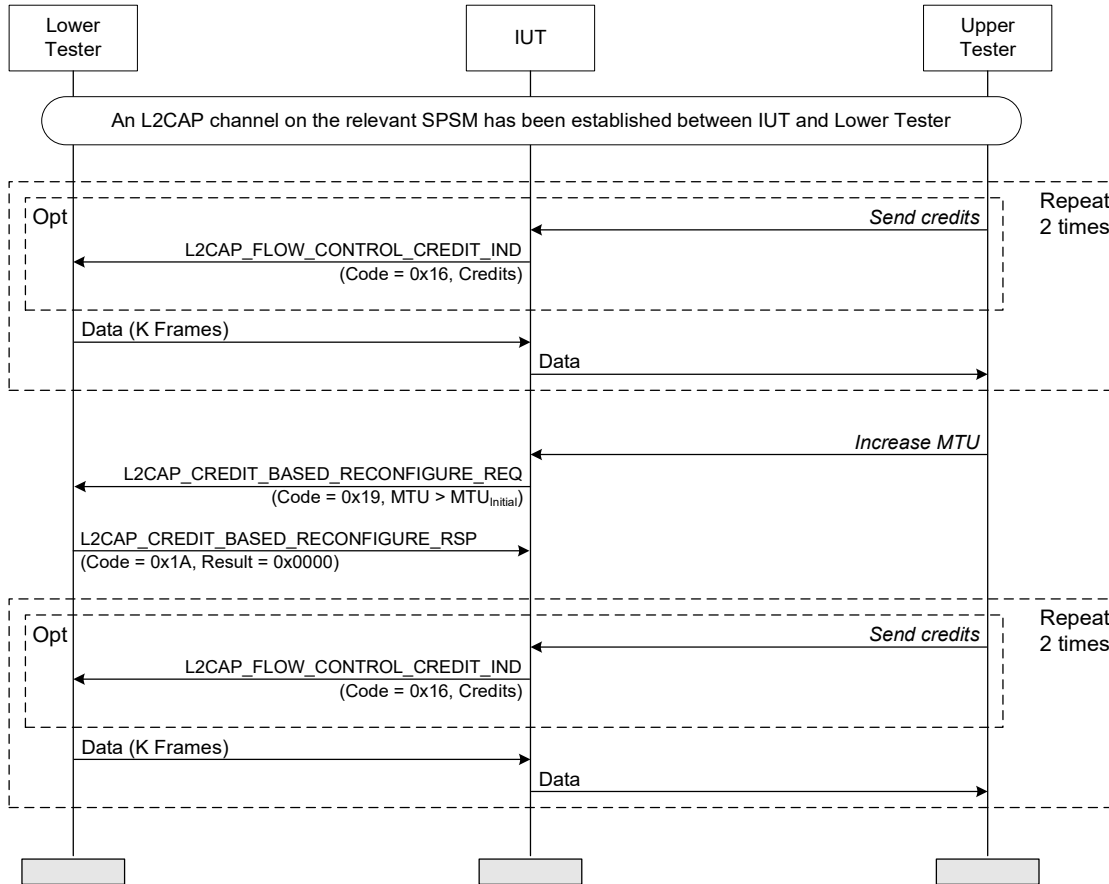

Figure 4.201: Renegotiate MTU – Initiator MSC

1. If the minimum supported MTU size equals the maximum supported MTU size or the current MTU size equals the maximum supported MTU size, the test ends with a Pass verdict.
2. The Lower Tester continuously transmits SDUs of a size that the MTU negotiated at channel initialization, at a minimum rate of two packets per second, over the L2CAP channel. Transmit at least 2 SDUs.
3. The Upper Tester commands the IUT to increase the MTU size for the opened channel.
4. The IUT sends an L2CAP_CREDIT_BASED_RECONFIGURE_REQ (Code = 0x19) packet to the Lower Tester, with the MTU field greater than the one in the initial configuration of the channel.
5. The Lower Tester sends an L2CAP_CREDIT_BASED_RECONFIGURE_RSP (Code = 0x1A) packet to the IUT, with the Result field equal to 0x0000 (Reconfiguration successful).
6. The Lower Tester transmits SDUs of a size equal to the MTU in Step 3 to the IUT. Transmit at least 2 SDUs.

- Expected Outcome

Pass verdict

Complete SDUs are sent to the Upper Tester, for Steps 3 and 6.

4.9.1.16 Renegotiate MTU – Responder

- Test Purpose

Verify that the IUT receiving an L2CAP Credit Based Reconfigure Request can reconfigure the Maximum Transmission Unit (MTU) for an indicated channel, being able to send larger SDUs.

- Reference

[13] 4.28

- Initial Condition

- The maximum supported MTU size is defined by the TSPX_l2ca_cbmtu_max IXIT entry.
- The minimum supported MTU size is defined by the TSPX_l2ca_cbmtu_min IXIT entry.
- The role of the IUT is indicated in the TSPX_iut_role_initiator IXIT value.
- The signaling channel specified in Table 4.43 is used.
- An SPSM for the Enhanced Credit Based Flow Control channel is declared via the TSPX_spsm IXIT value.
- The Lower Tester's initial MTU is equal to the IUT's minimum MTU size from the TSPX_tester_mtu IXIT value.

- Test Case Configuration

Test Case ID	Signaling Channel
L2CAP/ECFC/BV-23-C [Renegotiate MTU – Responder, LE]	0x0005
L2CAP/ECFC/BV-59-C [Renegotiate MTU – Responder, BR/EDR]	0x0001

Table 4.43: Renegotiate MTU – Responder test cases

• Test Procedure

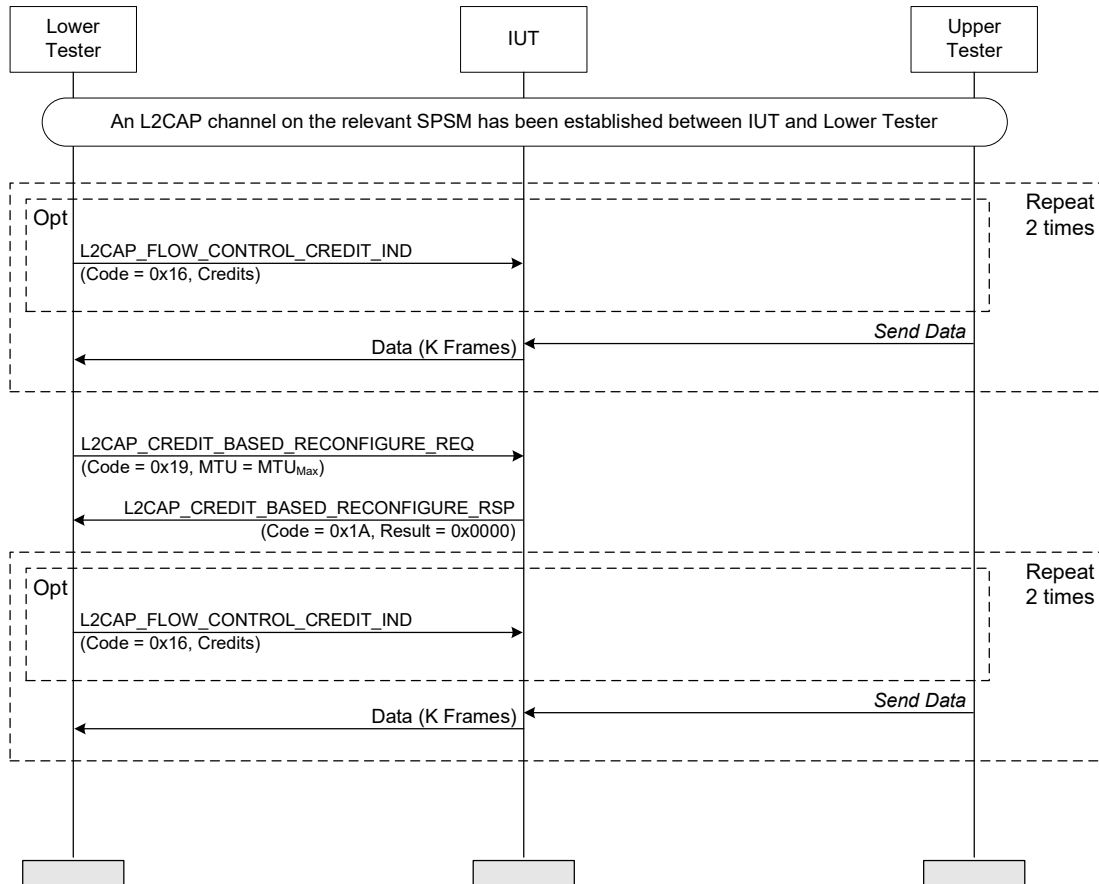

Figure 4.202: Renegotiate MTU – Responder MSC

1. If the minimum supported MTU size equals the maximum supported MTU size or the current MTU size equals the maximum supported MTU size, the test ends with a Pass verdict.
2. The Upper Tester commands the IUT to continuously transmit SDUs of a size equal to the MTU negotiated at channel initialization over the L2CAP channel at a minimum rate of two packets per second. Transmit at least 2 SDUs.
3. The Lower Tester sends an L2CAP_CREDIT_BASED_RECONFIGURE_REQ (Code = 0x19) packet to the IUT, with the MTU field set to the IUT’s maximum MTU size from IXIT.
4. The IUT sends an L2CAP_CREDIT_BASED_RECONFIGURE_RSP (Code = 0x1A) packet to the Lower Tester, with the Result field equal to 0x0000 (Reconfiguration successful).
5. The Upper Tester commands the IUT to transmit SDUs of a size equal to the MTU in Step 3 to the Lower Tester. Transmit at least 2 SDUs.

• Expected Outcome

Pass verdict

Complete SDUs are sent to the Upper Tester, for Steps 2 and 5.

4.9.1.17 Renegotiate MTU – MTU value is decreased

- Test Purpose

Verify that the IUT refuses the MTU reconfiguration request for a Data Channel created through Enhanced Credit Based Flow Control Mode when receiving an L2CAP Credit Based Reconfigure Request with a lower MTU value than the existing one.

- Reference

[13] 4.27

- Initial Condition

- The signaling channel specified in Table 4.44 is used.
- An SPSM for the Enhanced Credit Based Flow Control channel is declared via the TSPX_spsm IXIT value.
- An LE or BR/EDR Data Channel is established on the SPSM declared via the TSPX_spsm IXIT value, with the MTU on the Lower Tester side of at least 65 octets.

- Test Case Configuration

Test Case ID	Signaling Channel
L2CAP/ECFC/BI-03-C [Renegotiate MTU – MTU value is decreased, LE]	0x0005
L2CAP/ECFC/BI-12-C [Renegotiate MTU – MTU value is decreased, BR/EDR]	0x0001

Table 4.44: Renegotiate MTU – MTU value is decreased test cases

- Test Procedure

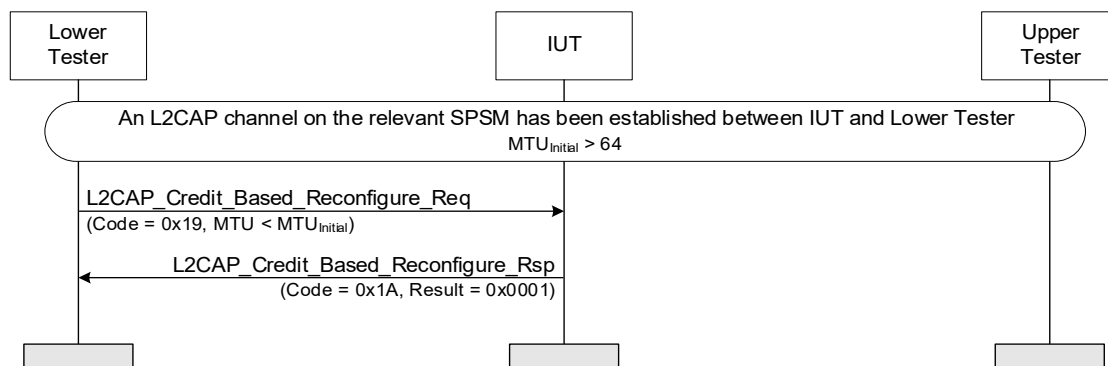

Figure 4.203: Renegotiate MTU – MTU value is decreased MSC

1. The Lower Tester sends an L2CAP Credit Based Reconfigure Request (Code = 0x19) packet to the IUT, with the MTU field lower than the one in the channel initial configuration.
2. The IUT does not disconnect the channel. The IUT sends an L2CAP Credit Based Reconfigure Response (Code = 0x1A) packet to the Lower Tester, with the Result field equal to 0x0001 (Reconfiguration failed - reduction in size of MTU not allowed).

- Expected Outcome

Pass verdict

In Step 2, the IUT sends a correctly formatted L2CAP Credit Based Reconfigure Response packet, with Result = 0x0001 (Reconfiguration failed - reduction in size of MTU not allowed).

4.9.1.18 Renegotiate MPS – Initiator

- Test Purpose

Verify that the IUT sending an L2CAP Credit Based Reconfigure Request can receive differently sized L2CAP PDUs on the indicated channels.

- Reference

[13] 4.27

- Initial Condition

- The signaling channel specified in [Table 4.45](#) is used.
- An SPSM for the Enhanced Credit Based Flow Control channel is declared via the TSPX_spsm IXIT value.
- The minimum supported IUT MPS size is defined by the TSPX_l2ca_cbmps_min IXIT entry.
- The maximum supported IUT MPS size is defined by the TSPX_l2ca_cbmps_max IXIT entry.

- Test Case Configuration

Test Case ID	Signaling Channel
L2CAP/ECFC/BV-24-C [Renegotiate MPS – Initiator, LE]	0x0005
L2CAP/ECFC/BV-60-C [Renegotiate MPS – Initiator, BR/EDR]	0x0001

Table 4.45: Renegotiate MPS – Initiator test cases

• Test Procedure

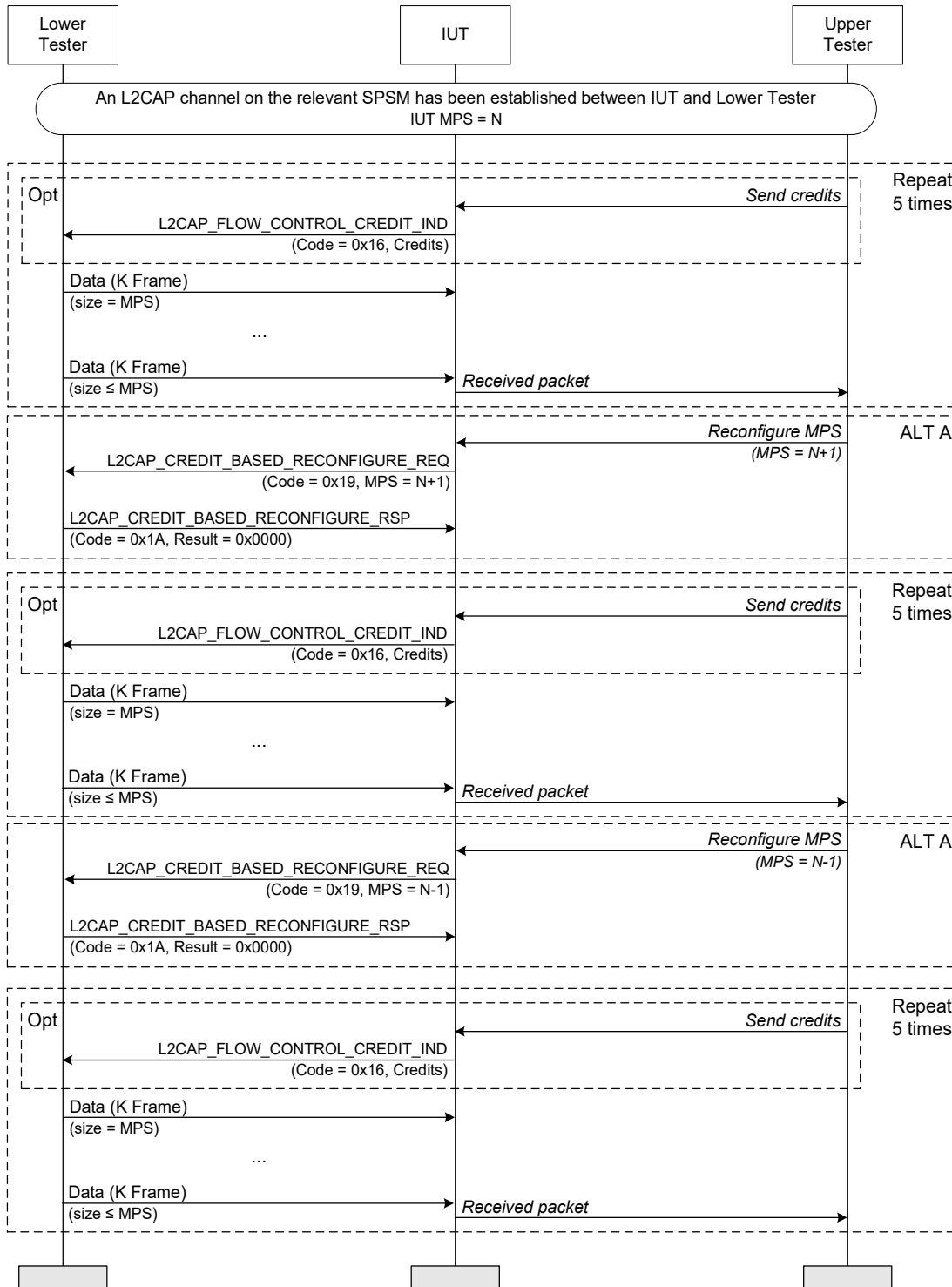

Figure 4.204: Renegotiate MPS – Initiator MSC

1. If TSPX_I2ca_cbmps_min equals TSPX_I2ca_cbmps_max, the test ends with a Pass verdict.
2. The IUT configures a value N for the MPS. If TSPX_I2ca_cbmps_max equals TSPX_I2ca_cbmps_min plus 1, then N equals TSPX_I2ca_cbmps_min. Otherwise, N is greater than TSPX_I2ca_cbmps_min and lower than TSPX_I2ca_cbmps_max. The Lower Tester

chooses, for the remaining steps, an SDU size that ensures that the Lower Tester performs segmentation.

3. The Lower Tester transmits SDUs (SDU size in Step 1) at a minimum rate of two packets per second, segmented into data packets with payload of size N over the L2CAP channel. Transmit at least 5 SDUs.
 4. The IUT sends an L2CAP Credit Based Reconfigure Request (Code = 0x19) packet to the Lower Tester, with MPS = N + 1 bytes.
 5. The Lower Tester sends an L2CAP Credit Based Reconfigure Response (Code = 0x1A) packet to the IUT, with the Result field equal to 0x0000 (Reconfiguration successful).
 6. The Lower Tester transmits SDUs (SDU size in Step 2), segmented into data packets with payload of size N + 1 to the IUT. Transmit at least 5 SDUs. If N = TSPX_I2ca_cbmps_min, skip to Step 9.
 7. The IUT sends an L2CAP_CREDIT_BASED_RECONFIGURE_REQ packet to the Lower Tester, with MPS = N – 1 bytes.
 8. The Lower Tester sends an L2CAP_CREDIT_BASED_RECONFIGURE_RSP packet to the IUT, with the Result field equal to 0x0000 (Reconfiguration successful).
 9. The Lower Tester transmits SDUs (SDU size in Step 2), segmented into data packets with payload of size N – 1 to the IUT. Transmit at least 5 SDUs.
- Expected Outcome

Pass verdict

Complete SDUs are sent to the Upper Tester in Steps 3, 6, and 9.

4.9.1.19 Renegotiate MPS – Responder

- Test Purpose

Verify that the IUT receiving an L2CAP Credit Based Reconfigure Request can send differently sized L2CAP PDUs on the indicated channel.

- Reference

[13] 4.28

- Initial Condition

- The minimum supported IUT MPS size is defined by the TSPX_I2ca_cbmps_min IXIT entry.
- The maximum supported IUT MPS size is defined by the TSPX_I2ca_cbmps_max IXIT entry.
- The signaling channel specified in [Table 4.46](#) is used.
- An SPSM for the Enhanced Credit Based Flow Control channel is declared via the TSPX_spsm IXIT value.
- The Lower Tester's initial MTU is equal to the IUT's maximum MTU size from the TSPX_I2ca_cbmtu_max IXIT value.
- The Lower Tester has configured a value N for the MPS, higher than TSPX_I2ca_cbmps_min and lower than TSPX_I2ca_cbmps_max, and the IUT chooses for transmitting an SDU size that, along with N, ensures that the IUT performs segmentation unless the IUT's max SDU size is the same as the MPS size.

- Test Case Configuration

Test Case ID	Signaling Channel
L2CAP/ECFC/BV-25-C [Renegotiate MPS – Responder, LE]	0x0005
L2CAP/ECFC/BV-61-C [Renegotiate MPS – Responder, BR/EDR]	0x0001

Table 4.46: Renegotiate MPS – Responder test cases

- Test Procedure

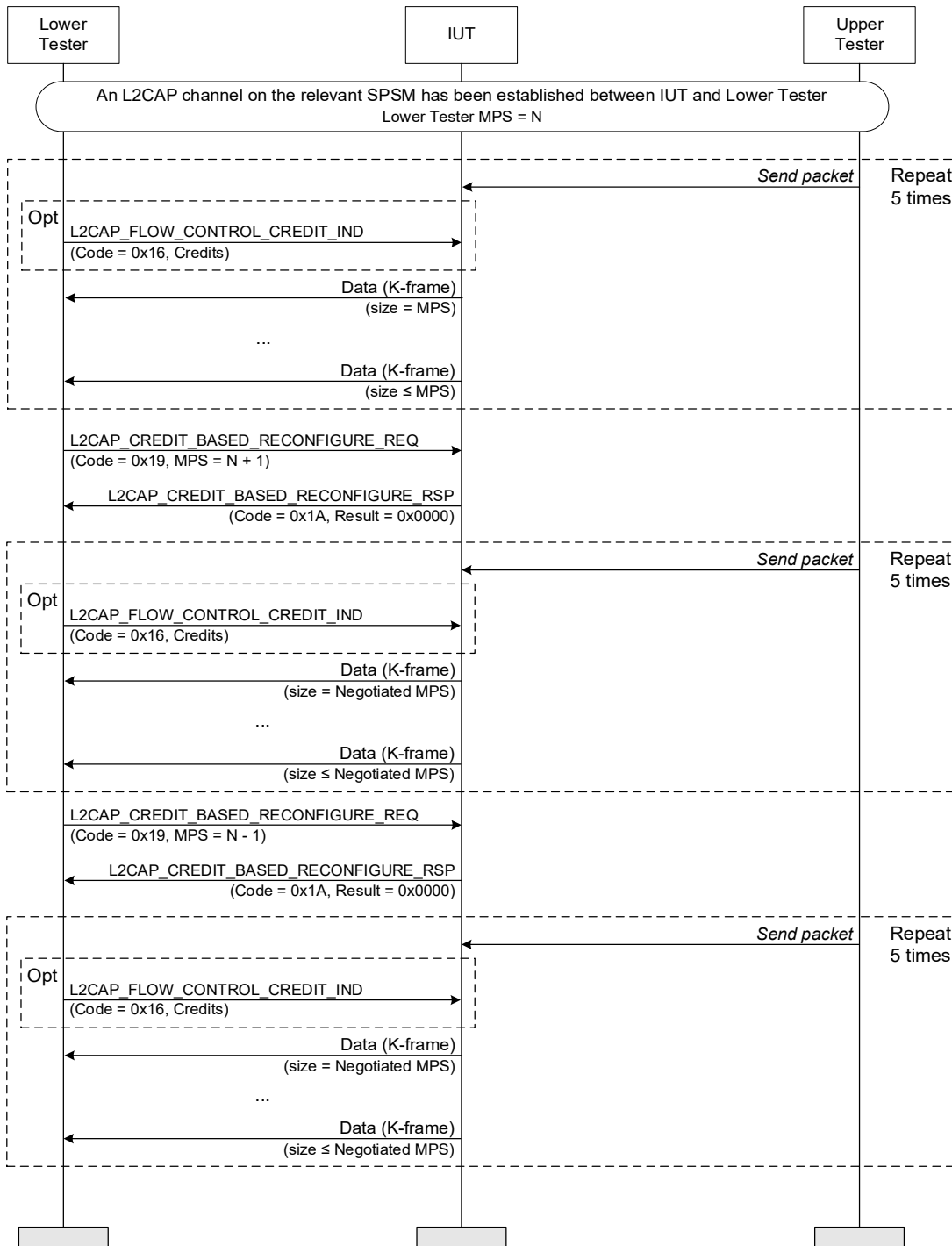

Figure 4.205: Renegotiate MPS – Responder MSC



1. If the minimum supported MPS size equals TSPX_I2ca_cbmps_max, the test ends with a Pass verdict.
2. If the MTU size equals MPS size, the test ends with a Pass verdict.
3. The Upper Tester commands the IUT to continuously transmits data packets (SDU size in Initial Condition) over the L2CAP channel at a minimum rate of 2 packets per second. Transmit at least 5 SDUs.
4. The IUT performs segmentation and transmit K-frames with payload equal to N (Lower Tester's MPS).
5. The Lower Tester sends an L2CAP_CREDIT_BASED_RECONFIGURE_REQ (Code = 0x19) packet to the IUT, with MPS = N + 1.
6. The IUT sends an L2CAP_CREDIT_BASED_RECONFIGURE_RSP (Code = 0x1A) packet to the Lower Tester, with the Result field equal to 0x0000 (Reconfiguration successful).
7. The Upper Tester commands the IUT to transmit data packets (SDU size in Initial Condition) to the Lower Tester. Transmit at least 5 SDUs.
8. The IUT performs segmentation and transmit K-frames with payload equal to N+1 unless N+1 exceeds TSPX_I2ca_cbmps_max from IXIT. If N = TSPX_I2ca_cbmps_min, then the test ends with a Pass verdict.
9. The Lower Tester sends an L2CAP_CREDIT_BASED_RECONFIGURE_REQ packet to the IUT, with MPS = N – 1 bytes.
10. The IUT sends an L2CAP_CREDIT_BASED_RECONFIGURE_RSP packet to the Lower Tester, with the Result field equal to 0x0000 (Reconfiguration successful).
11. The Upper Tester commands the IUT to transmit data packets (SDU size in Initial Condition) to the Lower Tester. Transmit at least 5 SDUs.
12. The IUT performs segmentation and transmit K-frames with payload equal to N – 1 unless N – 1 is lower than TSPX_I2ca_cbmps_min.

- Expected Outcome

Pass verdict

For each of the Steps 3, 8, and 12, the IUT segments the SDUs to a length no greater than the previously negotiated MPS size and send correct frames to the Lower Tester.

4.9.1.20 Renegotiate MPS – MPS value is decreased

- Test Purpose

Verify that the IUT refuses the MPS reconfiguration request for multiple Data Channels created through Enhanced Credit Based Flow Control Mode, when receiving an L2CAP Credit Based Reconfigure Request with lower MPS value than the existing one for multiple channels and when receiving an L2CAP Credit Based Reconfigure Request with an MPS value between other existing MPS values for multiple channels.

- Reference

[15] 4.27

- Initial Condition

- The TSPX_I2ca_cbmps_min and TSPX_I2ca_cbmps_max IXIT values give the minimum and maximum supported IUT MPS size.
- The signaling channel specified in Table 4.47 is used.
- An SPSM for the Credit Based Flow Control channel is declared via the TSPX_spsm IXIT value.



• Test Case Configuration

Test Case ID	Signaling Channel
L2CAP/ECFC/BI-04-C [Renegotiate MPS – MPS value is decreased, LE]	0x0005
L2CAP/ECFC/BI-13-C [Renegotiate MPS – MPS value is decreased, BR/EDR]	0x0001

Table 4.47: Renegotiate MPS – MPS value is decreased test cases

• Test Procedure

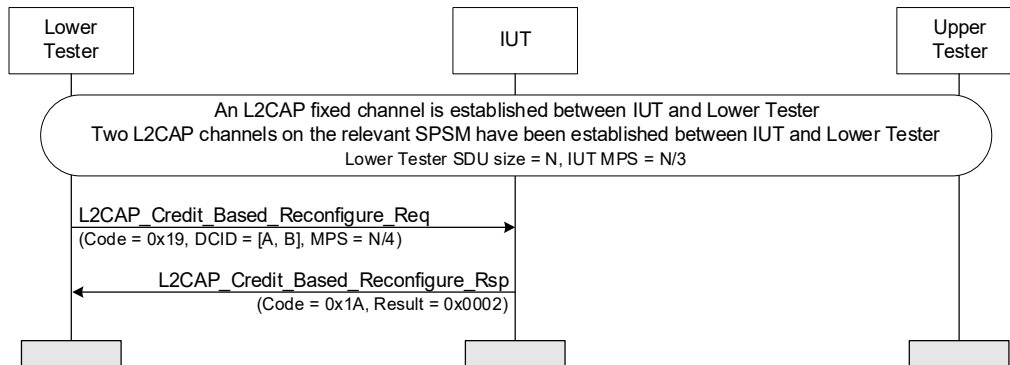

Figure 4.206: Renegotiate MPS – MPS value is decreased MSC

1. The Lower Tester sends an L2CAP Credit Based Reconfigure Request packet to the IUT, with Destination CID containing the list of CIDs of the opened channels and with a lower MPS value (in octets) than what was negotiated in the channel’s establishment. The lower MPS value must be at least 1 octet lower than the previous value.
2. The IUT sends an L2CAP Credit Based Reconfigure Response (Code = 0x1A) packet to the Lower Tester, with the Result field equal to 0x0002 (Reconfiguration failed - reduction in size of MPS not allowed for more than one channel at a time). The IUT does not disconnect any of the channels requested in Step 1.
3. The Lower Tester sends an L2CAP Credit Based Reconfigure Request packet to the IUT, with Destination CID containing the list of CIDs of the opened channels and with an MPS value (in octets) that is between the minimum MPS value of the Destination CIDs and the maximum MPS value of the Destination CIDs that were negotiated for in each of the channels established.
4. The IUT sends an L2CAP Credit Based Reconfigure Response (Code = 0x1A) packet to the Lower Tester, with the Result field set to any valid error code. The IUT does not disconnect any of the channels requested in Step 3.

• Expected Outcome

Pass verdict

In Step 2, the IUT sends a correctly formatted L2CAP Credit Based Reconfigure Response packet, with Result = 0x0002 (Reconfiguration failed - reduction in size of MPS not allowed for more than one channel at a time).

In Step 4, the IUT sends a correctly formatted L2CAP Credit Based Reconfigure Response packet, with Result set to any valid error code.

4.9.1.21 L2CAP Credit Based Connection Response – refused due to Invalid Parameters

- Test Purpose

Verify that an IUT does not establish any of the requested channels upon receiving an L2CAP Credit Based Connection Request containing a parameter with a value outside specifications and responds with result 0x000C (“All connections refused – invalid parameters”).

- Reference

[13] 4.26

- Initial Condition

- The signaling channel specified in Table 4.48 is used.
- An SPSM for the Enhanced Credit Based Flow Control channel is declared via the TSPX_spsm IXIT value.

- Test Case Configuration

Test Case ID	Signaling Channel
L2CAP/ECFC/BV-26-C [L2CAP Credit Based Connection Response – refused due to Invalid Parameters, LE]	0x0005
L2CAP/ECFC/BV-62-C [L2CAP Credit Based Connection Response – refused due to Invalid Parameters, BR/EDR]	0x0001

Table 4.48: L2CAP Credit Based Connection Response – refused due to Invalid Parameters test cases

- Test Procedure

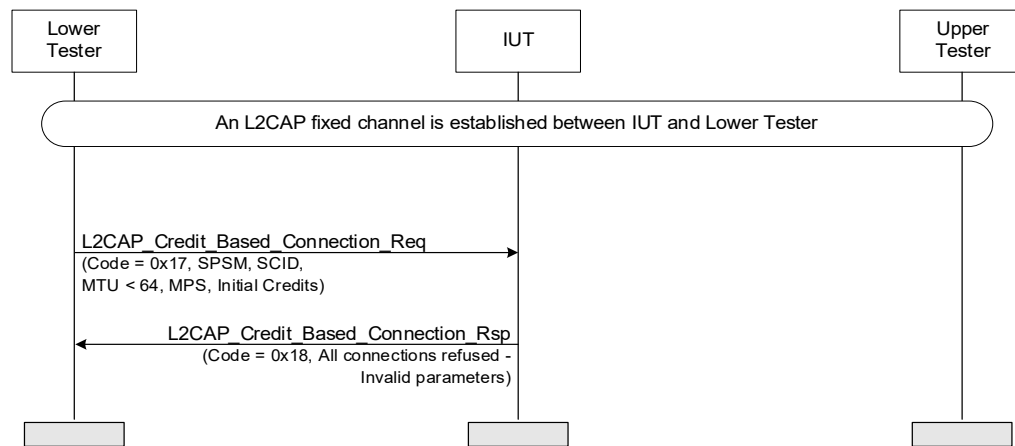

Figure 4.207: L2CAP Credit Based Connection Response – refused due to Invalid Parameters MSC

1. The Lower Tester sends an L2CAP Credit Based Connection Request (Code = 0x17) with the SPSM declared via IXIT and an MTU value less than 64.
2. The IUT rejects the connection request sending an L2CAP Credit Based Connection Response (Code = 0x18) to the Lower Tester with Result 0x000C (“All connections refused – invalid parameters”).

- Expected Outcome

Pass verdict

In Step 2, the IUT sends a correctly formatted L2CAP Credit Based Connection Response to the Lower Tester with result 0x000C (“All connections refused – Invalid parameters”).

4.9.1.22 L2CAP Credit Based Connection Response – refused due to Unacceptable Parameters

- Test Purpose

Verify that an IUT does not establish any of the requested channels upon receiving an L2CAP Credit Based Connection Request containing a parameter with a value unacceptable for the Host and responds with result 0x000B (“All connections refused – unacceptable parameters”).

- Reference

[13] 4.26

- Initial Condition

- TSPX_I2ca_cbmtu_min in the IXIT statement [3] is used to give the minimum peer MTU size that the IUT can accept on L2CAP Credit Based channels. The IXIT entry TSPX_I2ca_cbmtu_min should not be set to 64 if the IUT can accept peer MTU size larger than 64 octets for Credit Based Connection Requests.
- The signaling channel specified in Table 4.49 is used.
- An SPSM for the Credit Based Flow Control channel is declared via the TSPX_spsm IXIT value.

- Test Case Configuration

Test Case ID	Signaling Channel
L2CAP/ECFC/BV-27-C [L2CAP Credit Based Connection Response – refused due to Unacceptable Parameters, LE]	0x0005
L2CAP/ECFC/BV-63-C [L2CAP Credit Based Connection Response – refused due to Unacceptable Parameters, BR/EDR]	0x0001

Table 4.49: L2CAP Credit Based Connection Response – refused due to Unacceptable Parameters test cases

- Test Procedure

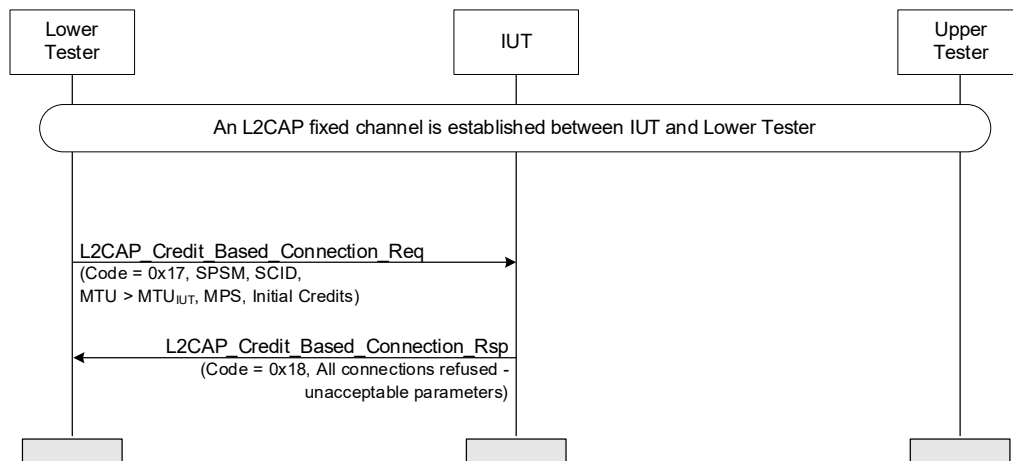

Figure 4.208: L2CAP Credit Based Connection Response – refused due to Unacceptable Parameters MSC

1. Perform alternative 1A or 1B depending on TSPX_I2ca_cbmtu_min.
 - Alternative 1A (TSPX_I2ca_cbmtu_min is greater than 64):
 - 1A.1 The Lower Tester sends an L2CAP Credit Based Connection Request (Code = 0x17) with the SPSM declared via IXIT and an MTU value lower than TSPX_I2ca_cbmtu_min.
 - 1A.2 The IUT rejects the connection request sending an L2CAP Credit Based Connection Response (Code = 0x18) to the Lower Tester with Result 0x000B (“All connections refused – unacceptable parameters”).
 - Alternative 1B (TSPX_I2ca_cbmtu_min is 64):
 - 1B.1 The Lower Tester sends an L2CAP Credit Based Connection Request (Code = 0x17) with the SPSM declared via IXIT and an MTU value equal to 64.
 - 1B.2 The channel is successfully established.

- Expected Outcome

Pass verdict

In Step 1A.2, the IUT sends a correctly formatted L2CAP Credit Based Connection Response to the Lower Tester with result 0x000B (“All connections refused – unacceptable parameters”).

In Step 1B.2, the channel is successfully established. The IUT sends a correctly formatted L2CAP Credit Based Connection Response to the Lower Tester with result 0x0000 (“All connections successful”).

4.9.1.23 Reconfigure – refused due to invalid Destination CID

- Test Purpose

Verify that the IUT refuses a reconfiguration request for a Data Channel created through Enhanced Credit Based Flow Control Mode, when receiving an L2CAP Credit Based Reconfigure Request with invalid Destination CID.

- Reference

[13] 4.27

- Initial Condition

- The TSPX_I2ca_cbmps_min and TSPX_I2ca_cbmps_max IXIT values give the minimum and maximum supported IUT MPS size.
- The signaling channel specified in Table 4.50 is used.
- An SPSM for the Credit Based Flow Control channel is declared via the TSPX_spsm IXIT value.

- Test Case Configuration

Test Case ID	Signaling Channel
L2CAP/ECFC/BI-05-C [Reconfigure – refused due to invalid Destination CID, LE]	0x0005
L2CAP/ECFC/BI-14-C [Reconfigure – refused due to invalid Destination CID, BR/EDR]	0x0001

Table 4.50: Reconfigure – refused due to invalid Destination CID test cases

• Test Procedure

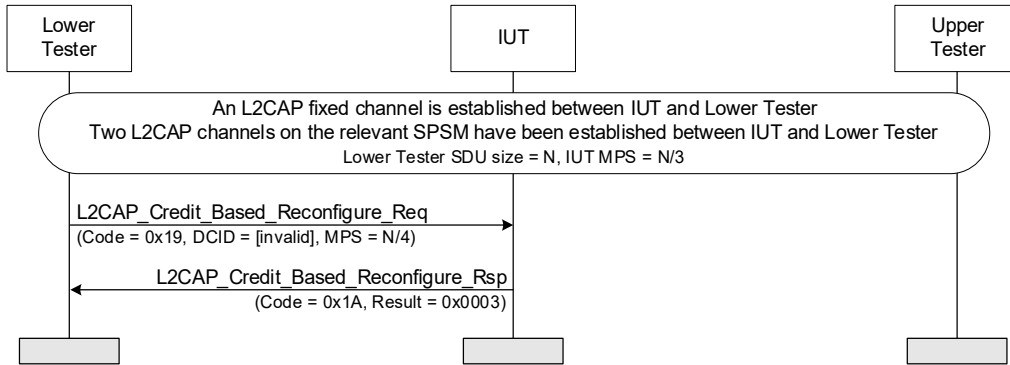

Figure 4.209: Reconfigure – refused due to invalid Destination CID MSC

1. The Lower Tester sends an L2CAP Credit Based Reconfigure Request packet to the IUT, with Destination CID containing one invalid CID and with valid MPS.
2. The IUT sends an L2CAP Credit Based Reconfigure Response (Code = 0x1A) packet to the Lower Tester, with the Result field equal to 0x0003 (Reconfiguration failed – one or more Destination CIDs invalid).

• Expected Outcome

Pass verdict

In Step 2, the IUT sends a correctly formatted L2CAP Credit Based Reconfigure Response packet, with Result = 0x0003 (Reconfiguration failed – one or more Destination CIDs invalid).

4.9.1.24 Reconfigure – other unacceptable parameters

• Test Purpose

Verify that the IUT refuses the MPS reconfiguration request for a Data Channel created through Enhanced Credit Based Flow Control Mode, when receiving an L2CAP Credit Based Reconfigure Request with an unacceptable MPS value.

• Reference

[13] 4.28

• Initial Condition

- The TSPX_l2ca_cbmps_min IXIT value gives the minimum supported IUT MPS size.
- The signaling channel specified in Table 4.51 is used.
- An SPSM for the Credit Based Flow Control channel is declared via the TSPX_spsm IXIT value.

• Test Case Configuration

Test Case ID	Signaling Channel
L2CAP/ECFC/BI-06-C [Reconfigure – other unacceptable parameters, LE]	0x0005
L2CAP/ECFC/BI-15-C [Reconfigure – other unacceptable parameters, BR/EDR]	0x0001

Table 4.51: Reconfigure – other unacceptable parameters test cases



• Test Procedure

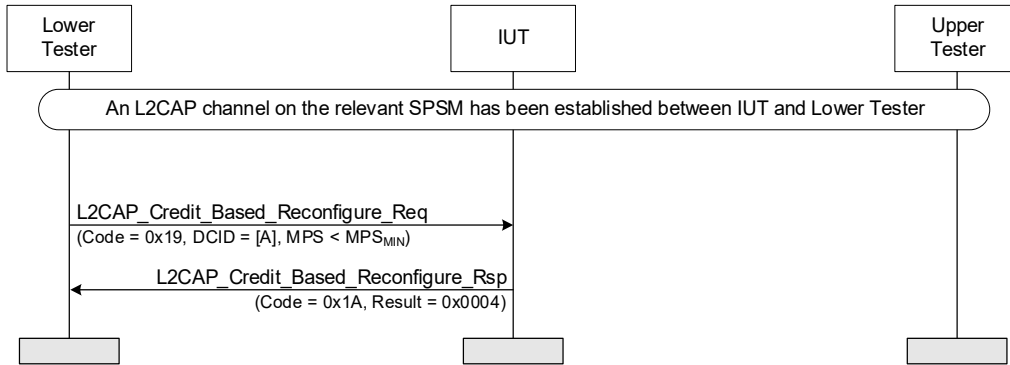

Figure 4.210: Reconfigure – other unacceptable parameters MSC

1. The Lower Tester sends an L2CAP Credit Based Reconfigure Request packet to the IUT, for the opened channel, with $MPS < MPS_{MIN}$ (minimum supported IUT MPS, as described in the IXIT).
2. The IUT sends an L2CAP Credit Based Reconfigure Response (Code = 0x1A) packet to the Lower Tester, with the Result field equal to 0x0004 (“Reconfiguration failed – other unacceptable parameters”).

• Expected Outcome

Pass verdict

In Step 2, the IUT sends a correctly formatted L2CAP Credit Based Reconfigure Response packet, with Result = 0x0004 (Reconfiguration failed – other unacceptable parameters).

4.9.1.25 L2CAP Credit Based Connection Response – Duplicate DCID

• Test Purpose

Verify that an IUT receiving an L2CAP_CREDIT_BASED_CONNECTION_RSP having a duplicate DCID detects the duplicate DCID and does not continue to use either the original channel or the new channel.

• Reference

[13] 4.26

• Initial Condition

- The signaling channel specified in Table 4.52 is used.
- An SPSM for the Enhanced Credit Based Flow Control channel is declared via the TSPX_spsm IXIT value. A Data Channel is established on the SPSM declared via the TSPX_spsm IXIT value.

• Test Case Configuration

Test Case ID	Signaling Channel
L2CAP/ECFC/BV-29-C [L2CAP Credit Based Connection Response – Duplicate DCID, LE]	0x0005
L2CAP/ECFC/BV-64-C [L2CAP Credit Based Connection Response – Duplicate DCID, BR/EDR]	0x0001

Table 4.52: L2CAP Credit Based Connection Response – Duplicate DCID test cases



- Test Procedure

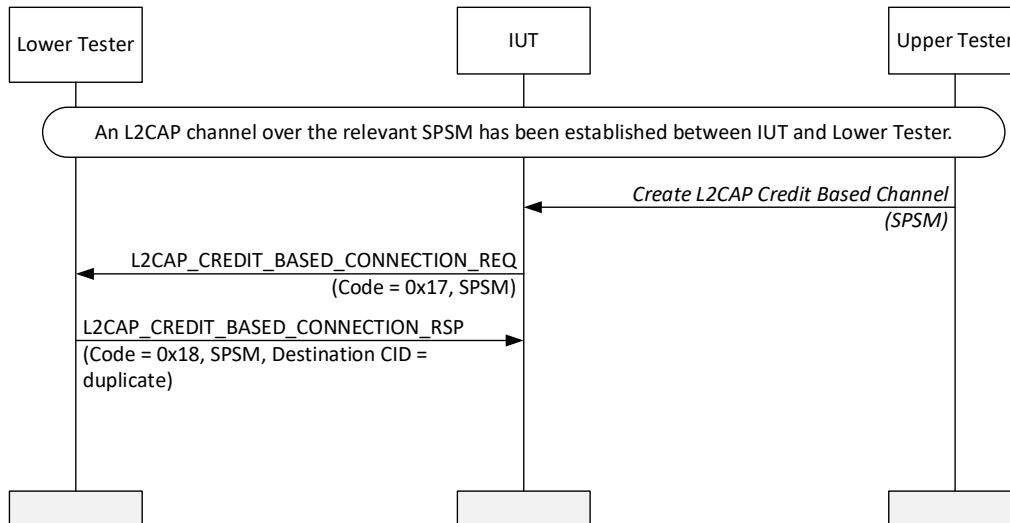

Figure 4.211: L2CAP Credit Based Connection Response – Duplicate DCID MSC

1. The Upper Tester commands the IUT to send a connection request on the SPSM declared via IXIT.
2. The IUT sends an L2CAP_CREDIT_BASED_CONNECTION_REQ (Code = 0x17) to the Lower Tester.
3. The Lower Tester sends an L2CAP_CREDIT_BASED_CONNECTION_RSP (Code = 0x18) having a duplicate DCID to the IUT.
4. The IUT detects the duplicate Destination CID and does not continue to use the original channel or the new channel. If a mechanism is available, the Upper Tester attempts to send data over each channel to verify this.

- Expected Outcome

Pass verdict

The IUT does not continue to use either the original channel or the new channel with the duplicate Destination CID.

4.9.1.26 Renegotiate MPS – MPS value is decreased, Multiple Channels

- Test Purpose

Verify that the IUT refuses the MPS reconfiguration request for multiple Data Channels created through Enhanced Credit Based Flow Control mode when receiving an L2CAP Credit Based Reconfigure Request with an MPS value between other existing MPU values for multiple channels.

- Reference

[15] 4.27

- Initial Condition

- The signaling channel specified in Table 4.53 is used.
- An SPSM for the Enhanced Credit Based Flow Control channel is declared via the TSPX_spsm IXIT value.

- A Data Channel is established on the SPSM declared via the TSPX_spsm IXIT value, with the MPS on the Lower Tester side of at least 65 octets.

- Test Case Configuration

Test Case ID	Signaling Channel
L2CAP/ECFC/BI-07-C [L2CAP Credit Based Connection Response – Duplicate DCID, LE]	0x0005
L2CAP/ECFC/BI-16-C [L2CAP Credit Based Connection Response – Duplicate DCID, BR/EDR]	0x0001

Table 4.53: L2CAP Credit Based Connection Response – Duplicate DCID test cases

- Test Procedure

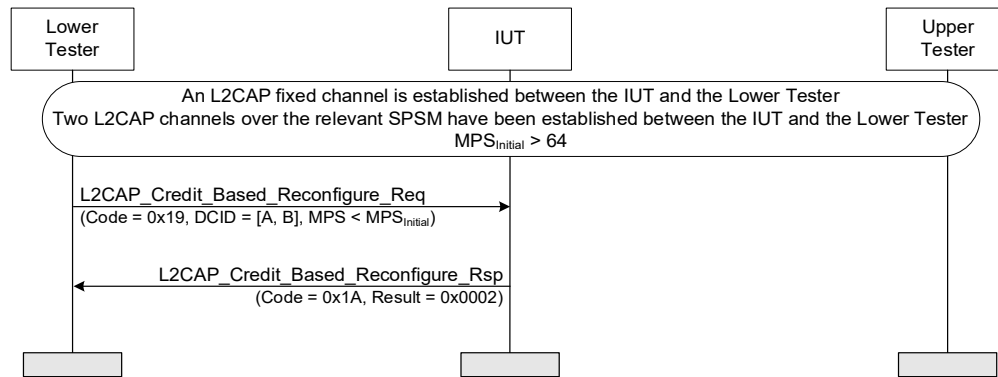

Figure 4.212: Renegotiate MPS – MPS value is decreased, Multiple Channels MSC

1. The Lower Tester sends an L2CAP Credit Based Reconfigure Request (Code = 0x19) packet to the IUT, with Destination CID containing the list of CIDs of the opened channels and with the MPS field value lower than the MPS value for one of the Destination CIDs that was negotiated during initial configuration.
2. The IUT does not disconnect the channel. The IUT sends an L2CAP Credit Based Reconfigure Response (Code = 0x1A) packet to the Lower Tester, with the Result field equal to 0x0002 (Reconfiguration failed - reduction in size of MPS not allowed for more than one channel at a time).

- Expected Outcome

Pass verdict

In Step 2, the IUT sends a correctly formatted L2CAP Credit Based Reconfigure Response packet, with Result = 0x0002 (Reconfiguration failed - reduction in size of MPS not allowed for more than one channel at a time).

4.9.2 LE Credit Based Flow Control Mode

L2CAP/LE/CFC/BV-01-C [LE Credit Based Connection Request - Legacy Peer]

- Test Purpose

Verify that an IUT sending an LE Credit Based Connection Request to a legacy peer and receiving a Command Reject does not establish the channel.

- Reference

[12] 4.22

- Initial Condition

- The appropriate signaling channel for the transport is used.
- An SPSM for the desired LE Credit Based Flow Control based Channel is declared via the TSPX_spsm IXIT value.

- Test Procedure

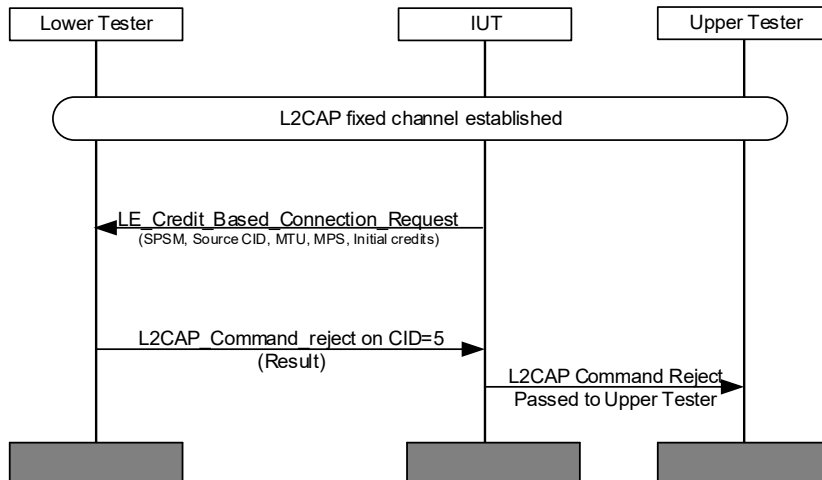

Figure 4.213: L2CAP/LE/CFC/BV-01-C [LE Credit Based Connection Request - Legacy Peer] MSC

The IUT sends an LE Credit Based Connection Request on an SPSM indicated in the IXIT.

The Lower Tester responds with a Command Reject.

- Expected Outcome

Pass verdict

After receiving the Command Reject from the Lower Tester, the IUT inform the Upper Tester.

L2CAP/LE/CFC/BV-02-C [LE Credit Based Connection Request on Supported SPSM]

- Test Purpose

Verify that an IUT sending an LE Credit Based Connection Request to a peer establishes the channel upon receiving the LE Credit Based Connection Response.

- Reference

[12] 4.22

- Initial Condition

- The appropriate signaling channel for the transport is used.
- An SPSM for the desired LE Credit Based Flow Control based Channel is declared in the TSPX_spsm IXIT value.
- The Upper Tester can command the IUT to send credits.

- Test Procedure

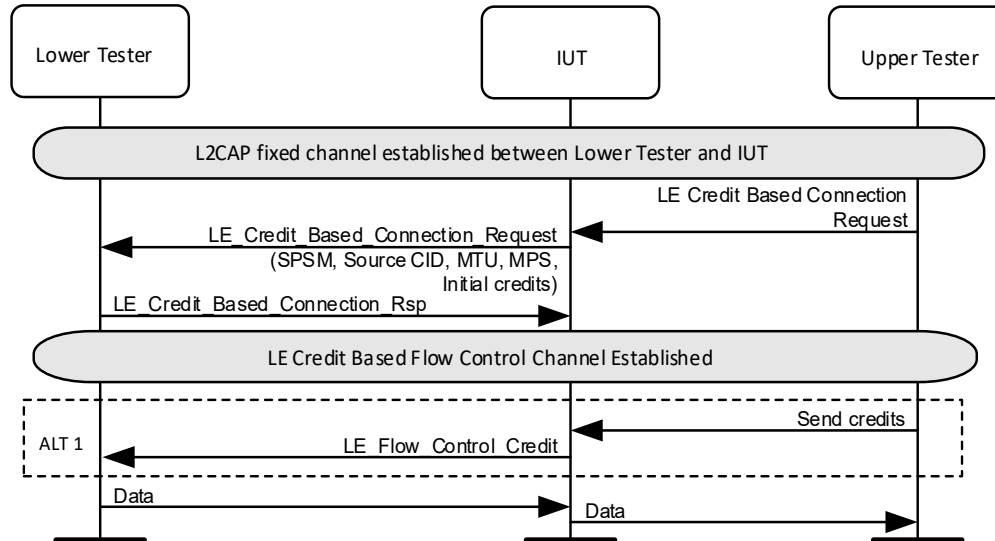

Figure 4.214: L2CAP/LE/CFC/BV-02-C [LE Credit Based Connection Request on Supported SPSM] MSC

The IUT sends an LE Credit Based Connection Request on the SPSM declared in IXIT.

The Lower Tester responds with an LE Credit Based Connection response PDU.

(ALT1) If the channel was created with zero credits, the Upper Tester issues a command to the IUT to send credits.

The Lower Tester sends data on the established channel.

- Expected Outcome

Pass verdict

The IUT receives the data send by the Lower Tester on the correct channel. The data is passed to the Upper Tester.

L2CAP/LE/CFC/BV-03-C [LE Credit Based Connection Response on Supported SPSM]

- Test Purpose

Verify that an IUT receiving a valid LE Credit Based Connection Request from a peer sends an LE Credit Based Connection Response and establishes the channel.

- Reference

[12] 4.23

- Initial Condition

- The appropriate signaling channel for the transport is used.
- An SPSM for the desired LE Credit Based Flow Control based channel is declared via the TSPX_spsm IXIT value.
- The Upper Tester can command the IUT to send data.

- Test Procedure

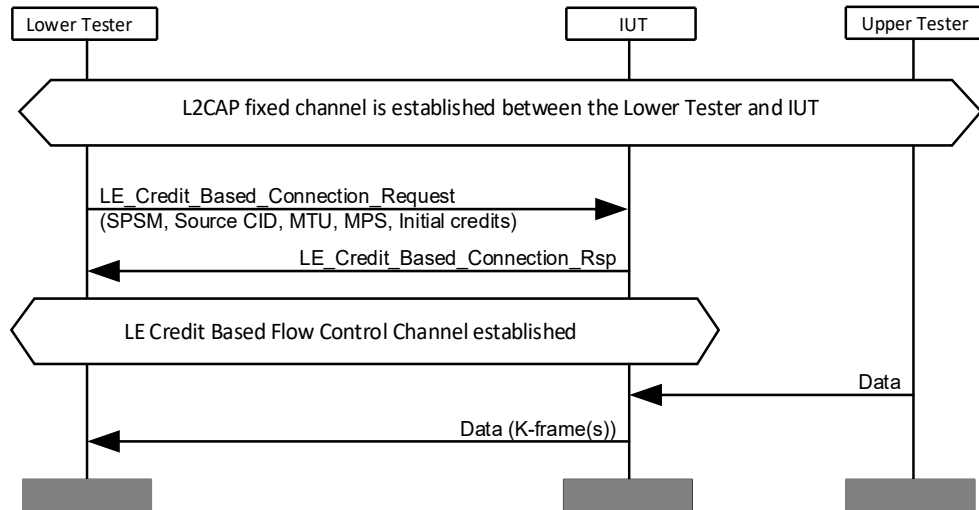

Figure 4.215: L2CAP/LE/CFC/BV-03-C [LE Credit Based Connection Response on Supported SPSM] MSC

The Lower Tester sends an LE Credit Based Connection Request with nonzero credits to the IUT on the SPSM specified in initial conditions.

The IUT responds with an LE Credit Based Connection Response.

The IUT is commanded to send data on the LE data channel by the Upper Tester.

- Expected Outcome

Pass verdict

The IUT sends one or more correctly formatted K-frames on the correct channel to the Lower Tester.

The data sent by the IUT to the Lower Tester matches the data sent by the Upper Tester to the IUT.

L2CAP/LE/CFC/BV-04-C [LE Credit Based Connection Request on an unsupported SPSM]

- Test Purpose

Verify that an IUT sending an LE Credit Based Connection Request on an unsupported SPSM does not establish a channel upon receiving an LE Credit Based Connection Response refusing the connection.

- Reference

[12] 4.22

- Initial Condition

- The appropriate signaling channel for the transport is used.
- An SPSM for an unsupported LE Credit Based Flow Control based channel is declared via the TSPX_psm_unsupported IXIT value.
- The Upper Tester can command the IUT to create a connection.

- Test Procedure

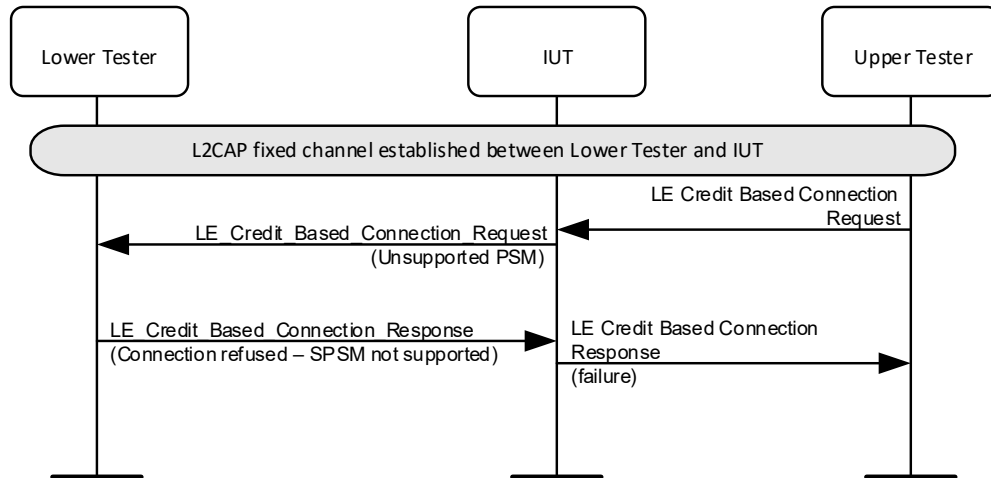

Figure 4.216: L2CAP/LE/CFC/BV-04-C [LE Credit Based Connection Request on an unsupported SPSM] MSC

The IUT sends an LE Credit Based Connection Request PDU on the SPSM specified in the initial conditions which is not supported by the Lower Tester.

The Lower Tester responds with an LE Credit Based Connection Response with result “0x0002 – Connection Refused – SPSM not supported”.

- Expected Outcome

Pass verdict

The IUT receives an LE Credit Based Connection Response PDU with result “0x0002 – Connection Refused – SPSM not supported” from the Lower Tester. This is indicated to the Upper Tester.

L2CAP/LE/CFC/BV-05-C [LE Credit Based Connection Request - unsupported SPSM]

- Test Purpose

Verify that an IUT receiving an LE Credit Based Connection Request on an unsupported SPSM responds with an LE Credit Based Connection Response refusing the connection.

- Reference

[12] 4.23

- Initial Condition

- The appropriate signaling channel for the transport is used.
- An SPSM for an unsupported LE Credit Based Flow Control based channel is declared via the TSPX_spsm IXIT value.

- Test Procedure

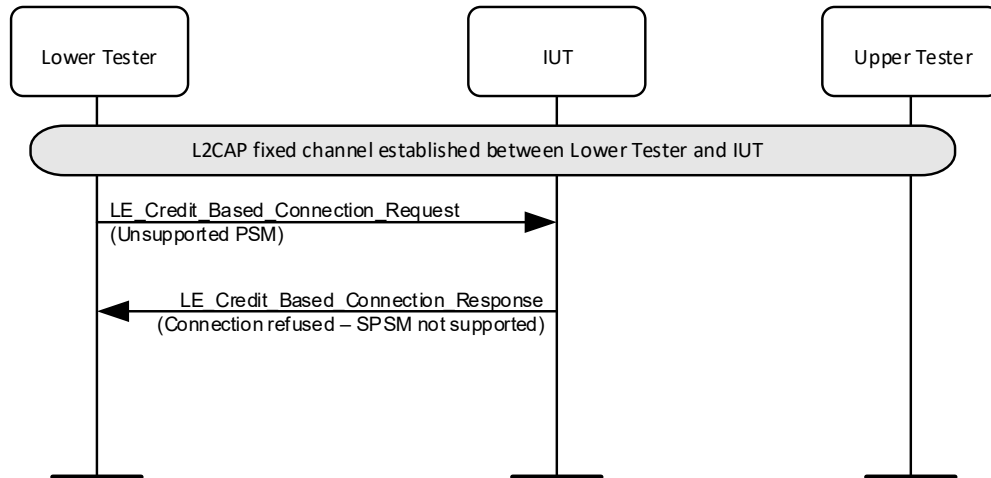

Figure 4.217: L2CAP/LE/CFC/BV-05-C [LE Credit Based Connection Request - unsupported SPSM] MSC

The Lower Tester sends an LE Credit Based Connection Request on the SPSM specified in initial conditions.

- Expected Outcome

Pass verdict

Upon receiving an LE Credit Based Connection Request containing an unsupported SPSM, the IUT sends a correctly formatted LE Credit Based Connection Response to the Lower Tester with Result “0x0002 – Connection Refused – SPSM not supported.”

L2CAP/LE/CFC/BV-06-C [Credit Exchange – Receiving Incremental Credits]

- Test Purpose

Verify that the IUT handles flow control correctly, by handling the LE Flow Control Credit sent by the peer.

- Reference

[12] 4.24

- Initial Condition

- The appropriate signaling channel for the transport is used.
- An LE Data Channel is established on an SPSM indicated in the TSPX_spsm IXIT value.
- The role of the IUT is indicated in the TSPX_iut_role_initiator IXIT value.
- The initial credit on the LE Data Channel set by the Lower Tester is 0.
- The Upper Tester can command the IUT to send data.

- Test Procedure

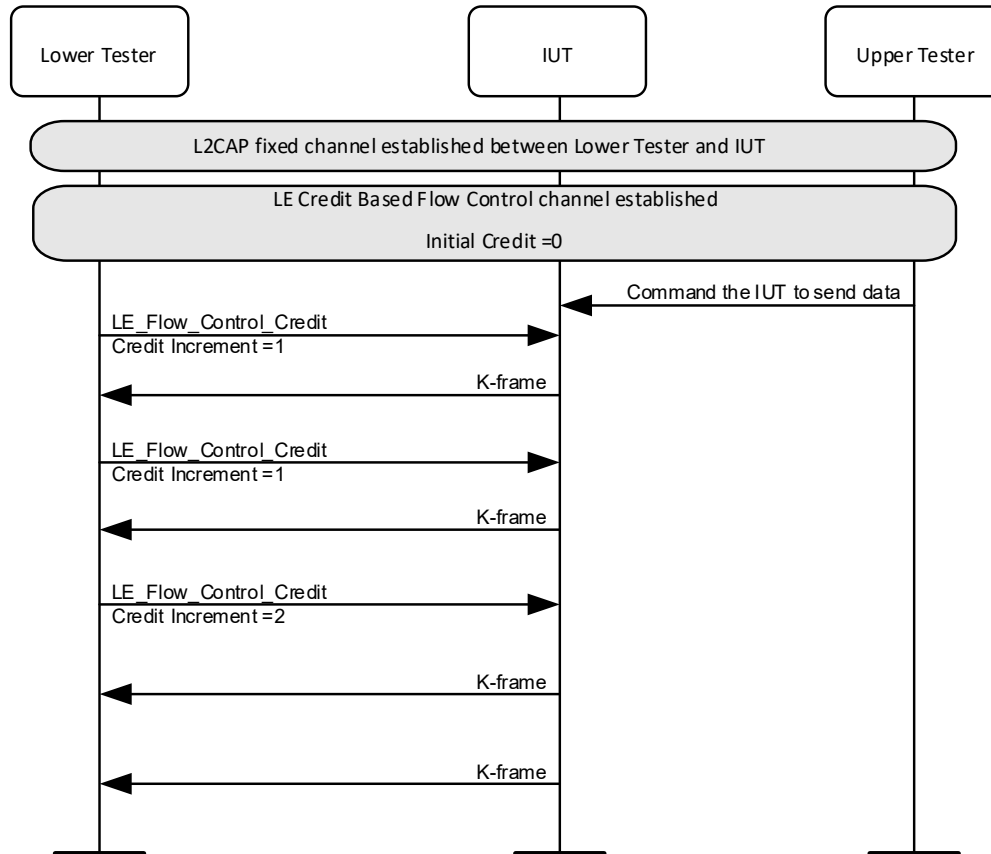

Figure 4.218: L2CAP/LE/CFC/BV-06-C [Credit Exchange – Receiving Incremental Credits] MSC

1. The Upper Tester requests the IUT to send data packets to the Lower Tester.
2. The Lower Tester sends an LE Flow Control Credit Packet with Credit Value X to the IUT on the CID.
3. The IUT now sends K-frames containing data to the Lower Tester.
4. After receiving X K-frames from the IUT and ensuring that no more K-frames are received, the Lower Tester sends a new LE Flow Control Credit packet with a Credits value of X on the CID. The IUT sends X K-frames containing data to the Lower Tester.
5. The Test Procedure Steps 2–4 are repeated with credit increment $X = \{1, >1\}$ without disconnecting the channel.

- Expected Outcome

Pass verdict

After receiving X credits, the IUT sends X correctly formatted K-frames containing data to the Lower Tester.

The IUT stops sending K-frames to the Lower Tester after the credit count X reaches zero.

After receiving X credits, the IUT sends (X) correctly formatted K-frames containing data to the Lower Tester.

The IUT stops sending K-frames to the Lower Tester after the credit count X reaches zero.

L2CAP/LE/CFC/BV-07-C [Credit Exchange – Sending Credits]

- Test Purpose

Verify that the IUT sends LE Flow Control Credit to the peer.
- Reference

[12] 4.24
- Initial Condition
 - The appropriate signaling channel for the transport is used.
 - An LE Data Channel is established on the SPSM declared via the TSPX_spsm IXIT value.
 - The role of the IUT is indicated in the TSPX_iut_role_initiator IXIT value.
 - The Upper Tester can command the IUT to send credits.
- Test Procedure

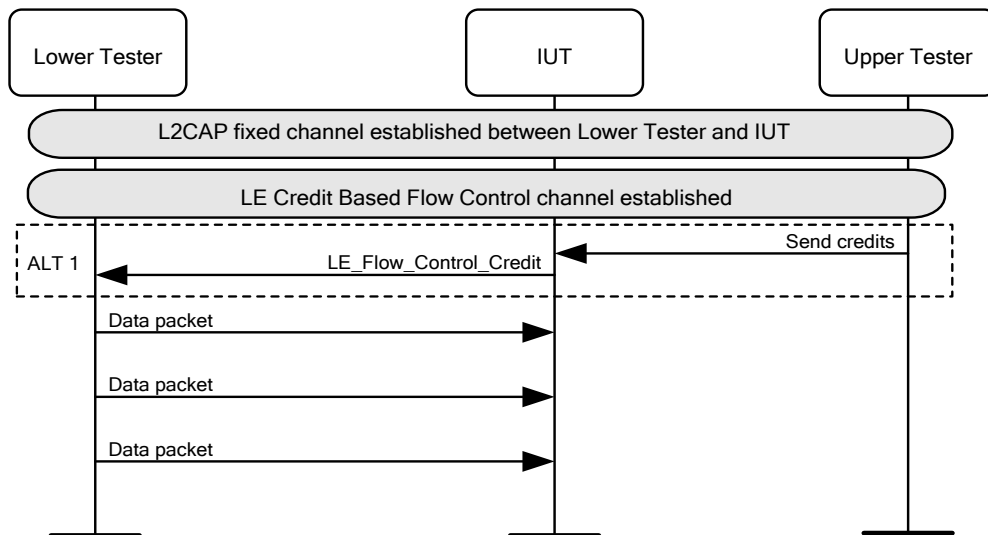

Figure 4.219: L2CAP/LE/CFC/BV-07-C [Credit Exchange – Sending Credits] MSC

(ALT1) If the channel was created with zero credits, the Upper Tester issues a command to the IUT to send credits.

The Lower Tester sends data packets to the IUT until it gets credits returned i.e., the data to send could consume more than the current credits available on the channel.

- Expected Outcome

Pass verdict

The IUT sends a correctly formatted LE Flow Control Credit packet to the Lower Tester minimum ones doing the data transfer.

L2CAP/LE/CFC/BI-01-C [Credit Exchange – Exceed Initial Credits]

- Test Purpose

Verify that the IUT disconnects the LE Data Channel when the credit count exceeds 65535.
- Reference

[12] 4.24, 10.1
- Initial Condition
 - The appropriate signaling channel for the transport is used.
 - An LE Data Channel is established on an SPSM indicated in the TSPX_spsm IXIT value.
 - The role of the IUT is indicated in the TSPX_iut_role_initiator IXIT value.
 - The initial credit on the LE Data Channel set by the Lower Tester is more than 1.
- Test Procedure

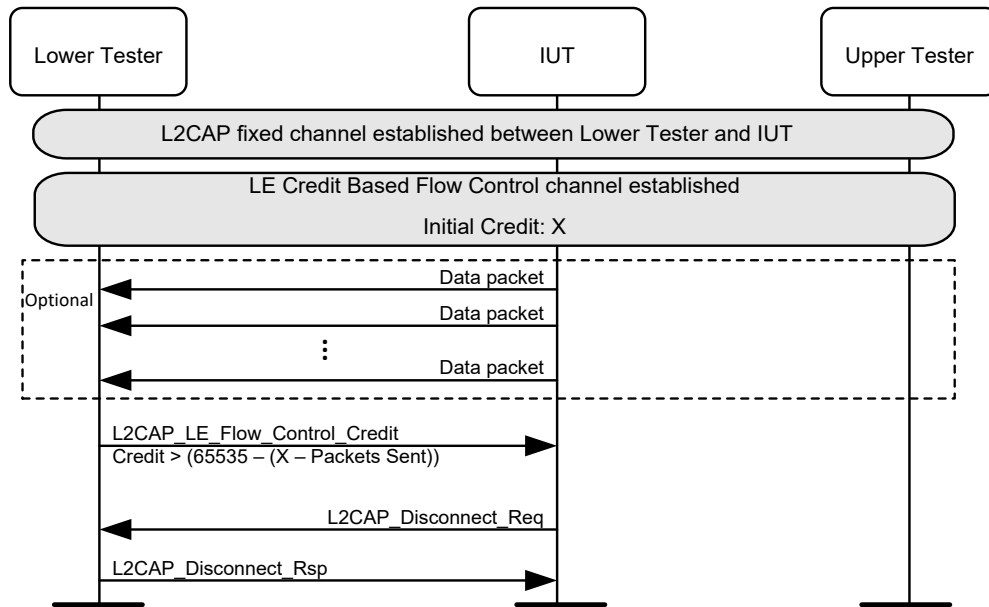

Figure 4.220: L2CAP/LE/CFC/BI-01-C [Credit Exchange – Exceed Initial Credits] MSC

(Optional) The IUT sends data packets to the Lower Tester.

The Lower Tester sends an LE Flow Control Credit PDU packet containing a credit so large that it together with the remaining credits on the IUT exceeds 65535.

- Expected Outcome

Pass verdict

Upon receiving a credit overflow, the IUT disconnects the LE Data Channel.

L2CAP/LE/CFC/BV-11-C [Security - Insufficient Authentication – Responder]

- Test Purpose

Verify that an IUT refuses to create a connection upon reception of an LE Credit Based Connection Request which fails to satisfy authentication requirements.
- Reference

[12] 4.22
- Initial Condition
 - The appropriate signaling channel for the transport is used.
 - An SPSM for the desired LE Credit Based Flow Control based Channel with authentication requirements is declared via the TSPX_psm_authentication_required IXIT value.
 - No authentication procedure has been performed between the IUT and the Lower Tester.
- Test Procedure

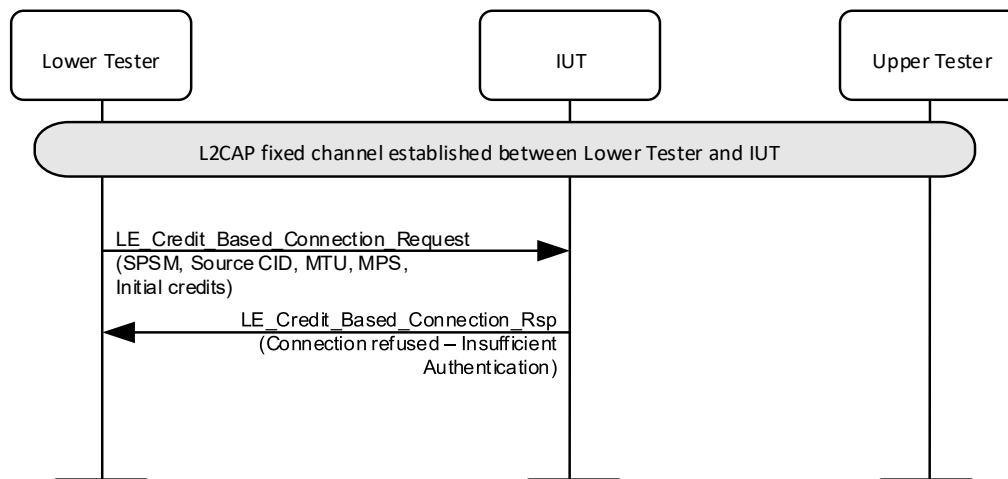

Figure 4.221: L2CAP/LE/CFC/BV-11-C [Security - Insufficient Authentication – Responder] MSC

1. The Lower Tester sends an LE Credit Based Connection Request on the SPSM specified in the initial conditions that requires authentication.
2. The IUT rejects the connection request with error code “Insufficient Authentication”.

- Expected Outcome

Pass verdict

Upon reception of an LE Credit Based Connection Request from the Lower Tester which fails to satisfy the authentication requirements, the IUT sends a correctly formatted LE Credit Based Connection Response with Result “0x0005 – Connection Refused – Insufficient Authentication” to the Lower Tester.

L2CAP/LE/CFC/BV-14-C [Security - Insufficient Encryption Key Size – Initiator]

- Test Purpose

Verify that the IUT does not establish the channel upon receipt of an LE Credit Based Connection Response indicating the connection was refused with Result “0x0007 – Connection Refused – Insufficient Encryption Key Size”.

- Reference
[12] 4.22
- Initial Condition
 - The appropriate signaling channel for the transport is used.
 - The Upper Tester can command the IUT to create a connection.
 - Either an Unauthenticated or Authenticated LTK exists between the IUT and Lower Tester.
- Test Procedure

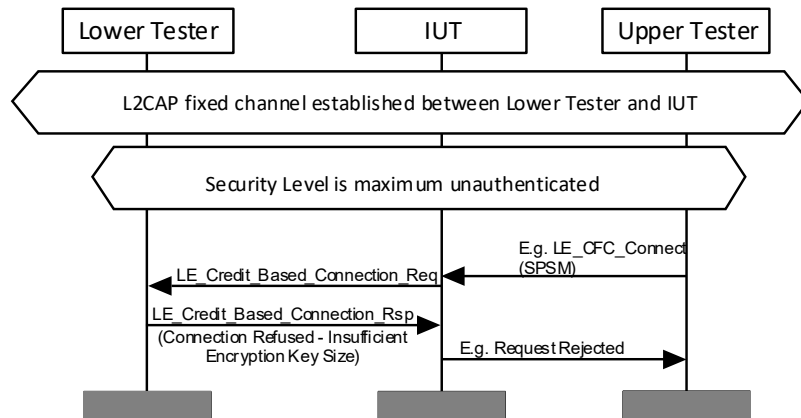

Figure 4.222: L2CAP/LE/CFC/BV-14-C [Security - Insufficient Encryption Key Size – Initiator] MSC

The Upper Tester commands the IUT to create a connection on an SPSM.

The Lower Tester refuses the Connection Request with result “0x0007 - Connection Refused - Insufficient Encryption Key Size”.

- Expected Outcome

Pass verdict

The IUT informs the Upper Tester about the rejection.

L2CAP/LE/CFC/BV-17-C [LE Credit Based Connection Response - refused due to insufficient resources - Responder]

- Test Purpose

Verify that an IUT receiving an LE Credit Based Connection Request for a second channel refuses the connection with result "0x0004 - Connection refused – no resources available" if it does not support multiple simultaneous channels.
- Reference
[12] 4.22
- Initial Condition
 - The appropriate signaling channel for the transport is used.
 - One LE Data channel is established on an SPSM declared via the TSPX_spsm IXIT value.

- Test Procedure

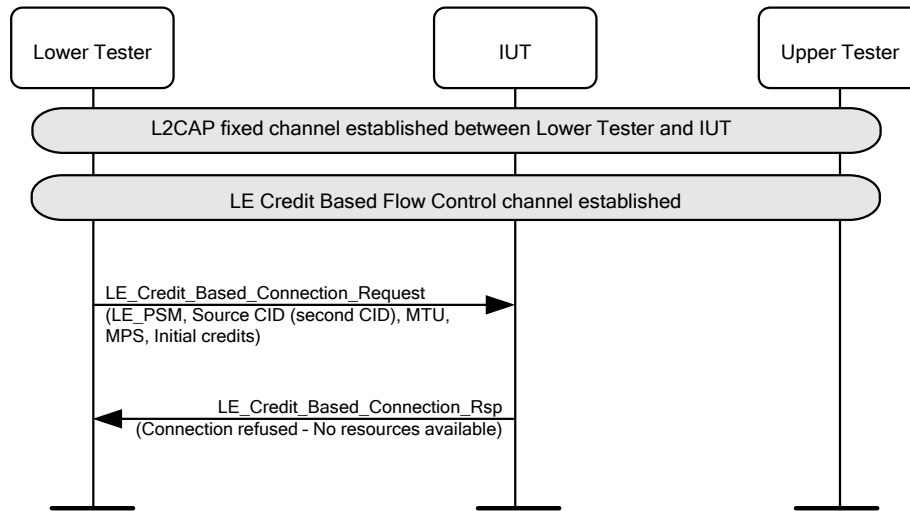

Figure 4.223: L2CAP/LE/CFC/BV-17-C [LE Credit Based Connection Response - refused due to insufficient resources - Responder] MSC

The Lower Tester sends an LE Credit Based Connection Request on a different CID to than the first.

- Expected Outcome

Pass verdict

Upon receiving an LE Credit Based Connection Request from the Lower Tester on a different CID than the previously-established channel, the IUT sends a correctly formatted LE Credit Based Connection Response to the Lower Tester with Result "0x0004 – Connection Refused – no resources available".

L2CAP/LE/CFC/BV-18-C [LE Credit Based Connection Request - refused due to Invalid Source CID - Initiator]

- Test Purpose

Verify that an IUT sending an LE Credit Based Connection Request does not establish the channel upon receiving an LE Credit Based Connection Response refusing the connection with result "0x0009 – Connection refused – Invalid Source CID".

- Reference

[12] 4.22

- Initial Condition

- The appropriate signaling channel for the transport is used.
- The Upper Tester can command the IUT to create a connection.

- Test Procedure

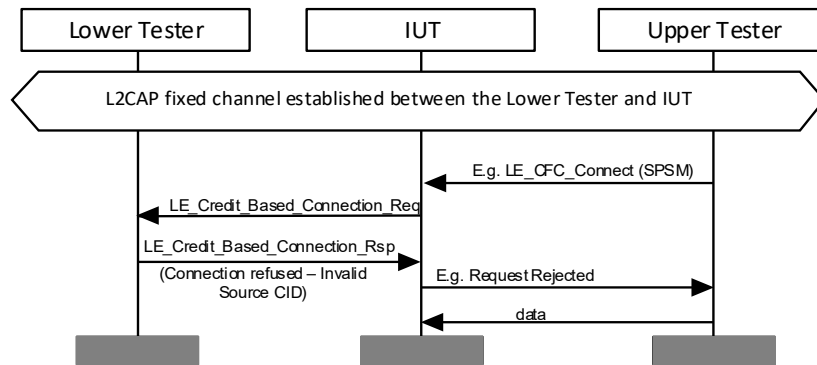

Figure 4.224: L2CAP/LE/CFC/BV-18-C [LE Credit Based Connection Request - refused due to Invalid Source CID - Initiator] MSC

The Upper Tester commands the IUT to create a connection on an SPSM.

The Lower Tester Refuses the Connection Request with an LE Credit Based Connection Response with result “0x0009 – Connection Refused – Invalid Source CID”.

The Upper Tester commands the IUT to send data on the refused CID.

- Expected Outcome

Pass verdict

The IUT informs the Upper Tester the connection was refused.

The Lower Tester does not receive any data from the IUT on the refused CID.

L2CAP/LE/CFC/BV-19-C [LE Credit Based Connection Request - refused due to source CID already allocated - Initiator]

- Test Purpose

Verify that an IUT sending an LE Credit Based Connection Request does not establish the channel upon receiving an LE Credit Based Connection Response refusing the connection with result "0x000A – Connection refused – Source CID already allocated".

- Reference

[12] 4.22

- Initial Condition

- The appropriate signaling channel for the transport is used.
- The Upper Tester can command the IUT to create a connection.

- Test Procedure

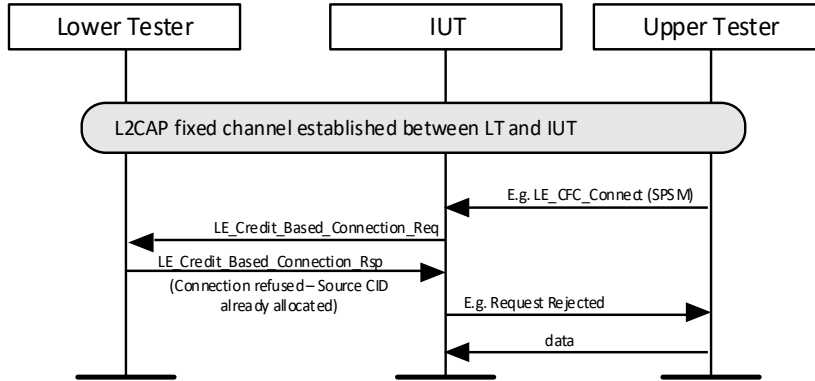

Figure 4.225: L2CAP/LE/CFC/BV-19-C [LE Credit Based Connection Request - refused due to source CID already allocated - Initiator] MSC

The Upper Tester commands the IUT to create a connection on an SPSM.

The Lower Tester Refuses the Connection Request with an LE Credit Based Connection Response with result “0x000A – Connection Refused – Source CID already allocated”.

The Upper Tester commands the IUT to send data on the refused CID.

- Expected Outcome

Pass verdict

The IUT informs the Upper Tester the connection was refused.

The Lower tester does not receive any data from the IUT on the refused CID.

L2CAP/LE/CFC/BV-20-C [LE Credit Based Connection Response - refused due to Source CID already allocated - Responder]

- Test Purpose

Verify that an IUT receiving an LE Credit Based Connection Request for a second channel refuses the connection with result "0x000A - Connection refused – Source CID already allocated" if it receives a Source CID which is already in use.

- Reference

[12] 4.23

- Initial Condition

- The appropriate signaling channel for the transport is used.
- One LE Data channel is established on an SPSM declared via the TSPX_spsm IXIT value.

- Test Procedure

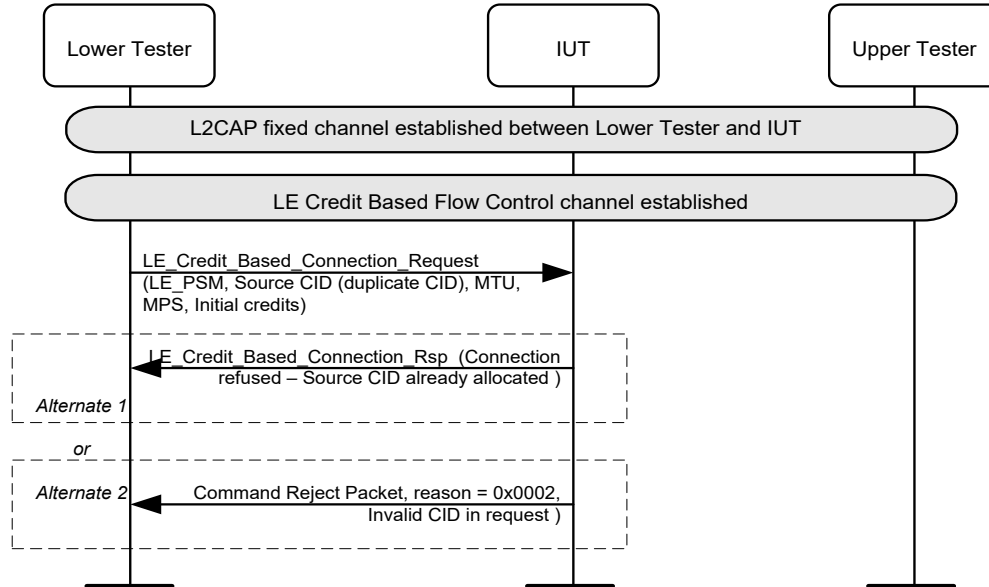

Figure 4.226: L2CAP/LE/CFC/BV-20-C [LE Credit Based Connection Response - refused due to Source CID already allocated - Responder] MSC

The Lower Tester sends an LE Credit Based Connection Request using the same CID as the previously established channel.

- Expected Outcome

Pass verdict

ALT1: Upon receipt of an LE Credit Based Connection Request using the same CID as the previously established channel, the IUT sends a correctly formatted LE Credit Based Connection Response to the Lower Tester with Result=0x000A - Connection Refused – Source CID already allocated.

ALT2: The IUT sends a correctly formatted Command Reject to the Lower Tester with Reason=0x0002 – Invalid CID in request.

L2CAP/LE/CFC/BV-21-C [LE Credit Based Connection Request - refused due to Unacceptable Parameters - Initiator]

- Test Purpose

Verify that an IUT sending an LE Credit Based Connection Request does not establish the channel upon receiving an LE Credit Based Connection Response refusing the connection with result “0x000B – Connection refused – Unacceptable Parameters”.

- Reference

[12] 4.22

- Initial Condition

- The appropriate signaling channel for the transport is used.
- The Upper Tester can command the IUT to create a connection.

- Test Procedure

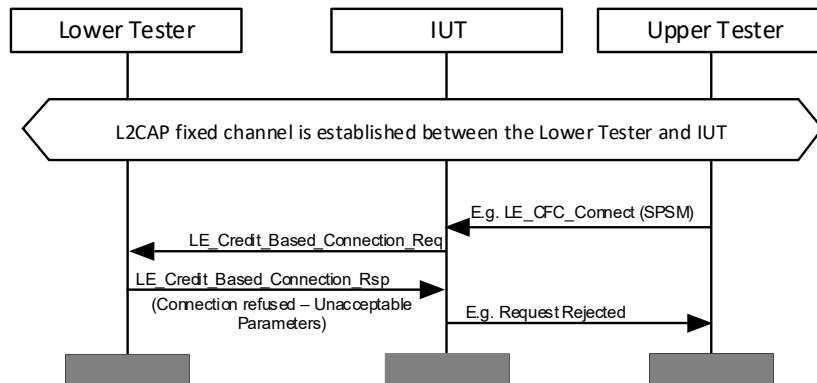

Figure 4.227: L2CAP/LE/CFC/BV-21-C [LE Credit Based Connection Request - refused due to Unacceptable Parameters - Initiator] MSC

The Upper Tester commands the IUT to create a connection on an SPSM.

The Lower Tester refuses the Connection Request with an LE Credit Based Connection Response with result “0x000B – Connection Refused – Unacceptable Parameters”.

The Upper Tester commands the IUT to send data on the refused CID.

- Expected Outcome

Pass verdict

The IUT informs the Upper Tester the connection was refused.

The Lower Tester does not receive any data from the IUT on the refused CID.

4.9.2.1 Credit Based Connection Request Dynamically Allocated Source CID

- Test Purpose

Verify that an IUT sending a Credit Based Connection Request to a peer allocates the Source CID from a dynamically allocated range and does not allocate one already in use.

- Reference

[12] 4.22

- Initial Condition

- The signaling channel specified in [Table 4.54](#) is used.
- An SPSM for the desired LE Credit Based or Enhanced Credit Based Flow Control based Channel is declared in the TSPX_spsm or the TSPX_spsm IXIT value.
- The Upper Tester can command the IUT to send credits.
- A value for the number of concurrent Credit Based Connections is defined by the TSPX_l2ca_num_concurrent_credit_based_connections IXIT value.

- Test Case Configuration

Test Case ID	Signaling Channel	L2CAP Command
L2CAP/ECFC/BV-38-C [Credit Based Connection Request Dynamically Allocated Source CID – LE]	0x0005	L2CAP_CREDIT_BASED_CONNECTION_REQ L2CAP_CREDIT_BASED_CONNECTION_RSP
L2CAP/LE/CFC/BV-29-C [Credit Based Connection Request Dynamically Allocated Source CID]	0x0005	L2CAP_LE_CREDIT_BASED_CONNECTION_REQ L2CAP_LE_CREDIT_BASED_CONNECTION_RSP
L2CAP/ECFC/BV-79-C [Credit Based Connection Request Dynamically Allocated Source CID – BR/EDR]	0x0001	L2CAP_CREDIT_BASED_CONNECTION_REQ L2CAP_CREDIT_BASED_CONNECTION_RSP

Table 4.54: Credit Based Connection Request Dynamically Allocated Source CID test cases

- Test Procedure

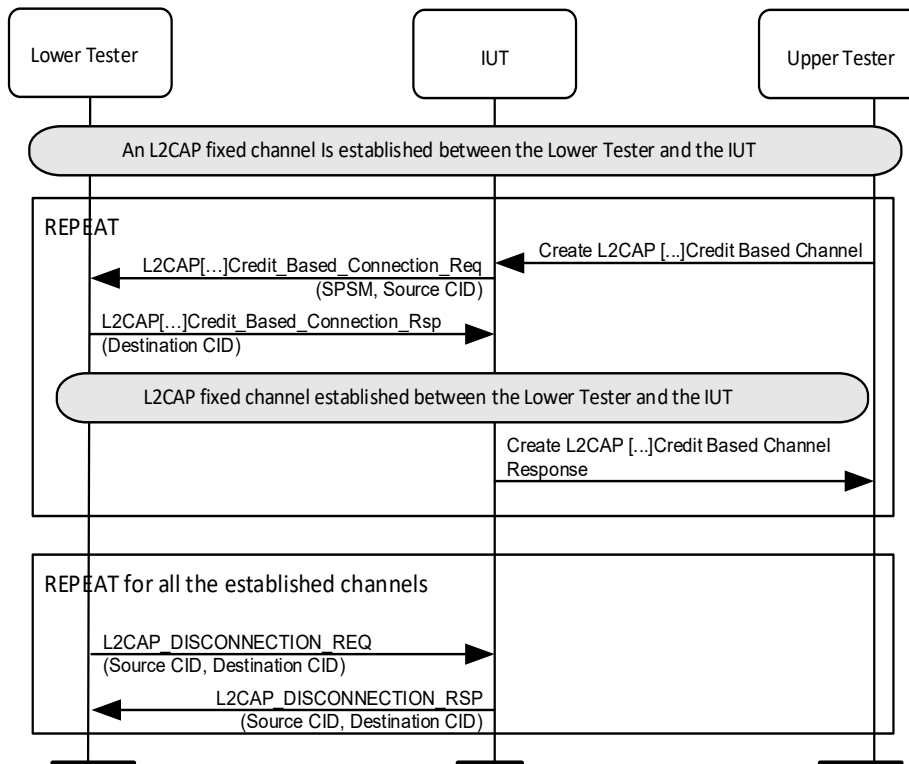

Figure 4.228: Credit Based Connection Request Dynamically Allocated Source CID MSC

1. Perform Steps 2–6 a total of TSPX_l2ca_num_concurrent_credit_based_connections times.
2. The Upper Tester commands the IUT to create an L2CAP connection to the Lower Tester.
3. The IUT sends an L2CAP request command as specified in Table 4.54 to the Lower Tester on the SPSM as specified in Table 4.54 with a Source CID.
4. The Lower Tester confirms that the Source CID received in Step 3 is within the range 0x0040–0x007F and is not the same as any of the Source CIDs received during this test procedure.
5. The Lower Tester sends an L2CAP response command as specified in Table 4.54 to the IUT with a Destination CID.

6. The IUT notifies the Upper Tester that an L2CAP connection was completed with the Source CID from Step 3 and the Destination CID received in Step 5.
7. Repeat Steps 8 and 9 for all established channels.
8. The Lower Tester sends an L2CAP_DISCONNECTION_REQ PDU to the IUT with the Source CID and the Destination CIDs from Steps 2–6.
9. The IUT sends an L2CAP_DISCONNECTION_RSP PDU to the Lower Tester with the Source CID and the Destination CIDs set as received in Step 8.

- Expected Outcome

Pass verdict

In Step 3, the Source CID in the L2CAP request command is in the range of 0x40–0x7F.

In each iteration of Step 3, the Source CID is not the same as any Source CID of an existing connection.

4.9.3 All Credit Based Flow Control Mode

4.9.3.1 Disconnection Request

- Test Purpose

Verify that the IUT can disconnect the channel.

- Initial Condition

- The signaling channel specified in [Table 4.55](#) is used.
- A Data Channel as specified in [Table 4.55](#) is established on the SPSM declared via the TSPX_spsm IXIT value using the commands specified in [Table 4.55](#).
- The role of the IUT is indicated in the TSPX_iut_role_initiator IXIT value.

- Test Case Configuration

Test Case ID	Reference	Signaling Channel	L2CAP Command
L2CAP/LE/CFC/BV-08-C [Disconnection Request]	[12] 4.6	0x0005	L2CAP_LE_CREDIT_BASED_CONNECTION_REQ/RSP
L2CAP/ECFC/BV-08-C [Disconnection Request, LE]	[13] 4.6	0x0005	L2CAP_CREDIT_BASED_CONNECTION_REQ/RSP
L2CAP/ECFC/BV-65-C [Disconnection Request, BR/EDR]	[13] 4.6	0x0001	L2CAP_CREDIT_BASED_CONNECTION_REQ/RSP

Table 4.55: Disconnection Request test cases



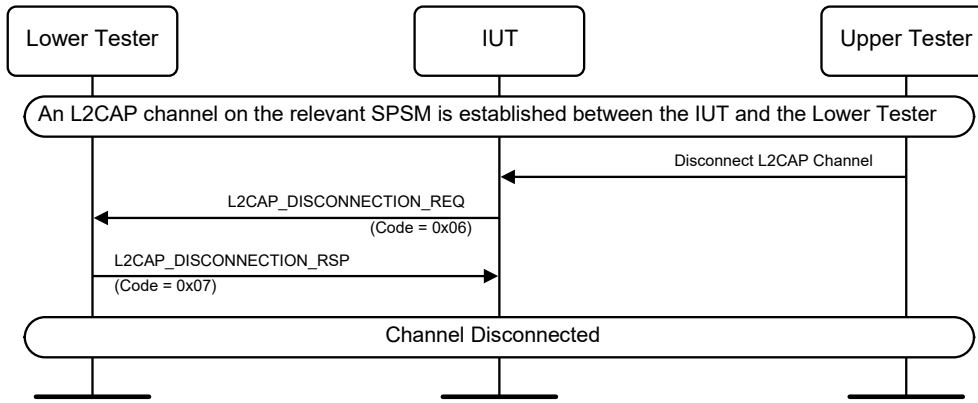

Figure 4.229: Disconnection Request MSC

1. The Upper Tester commands the IUT to disconnect the channel.
2. The IUT sends L2CAP Disconnection Request (Code = 0x06) to the Lower Tester.
3. The Lower Tester sends an L2CAP Disconnection Response (Code = 0x07).

- Expected Outcome

Pass verdict

The IUT sends a correctly formatted L2CAP_DISCONNECTION_REQ to the Lower Tester.

4.9.3.2 Disconnection Response

- Test Purpose

Verify that the IUT responds correctly to reception of a Disconnection Request.

- Initial Condition

- The signaling channel specified in [Table 4.56](#) is used.
- A Data Channel as specified in [Table 4.56](#) is established on the SPSM declared via the TSPX_spsm IXIT value using the commands specified in [Table 4.56](#).
- The role of the IUT is indicated in the TSPX_iut_role_initiator IXIT value.

- Test Case Configuration

Test Case ID	Reference	Signaling Channel	L2CAP Command
L2CAP/LE/CFC/BV-09-C [Disconnection Response]	[12] 4.7	0x0005	L2CAP_LE_CREDIT_BASED_CONNECTION_REQ/RSP
L2CAP/ECFC/BV-09-C [Disconnection Response, LE]	[13] 4.7	0x0005	L2CAP_CREDIT_BASED_CONNECTION_REQ/RSP
L2CAP/ECFC/BV-66-C [Disconnection Response, BR/EDR]	[13] 4.7	0x0001	L2CAP_CREDIT_BASED_CONNECTION_REQ/RSP

Table 4.56: Disconnection Response test cases



- Test Procedure

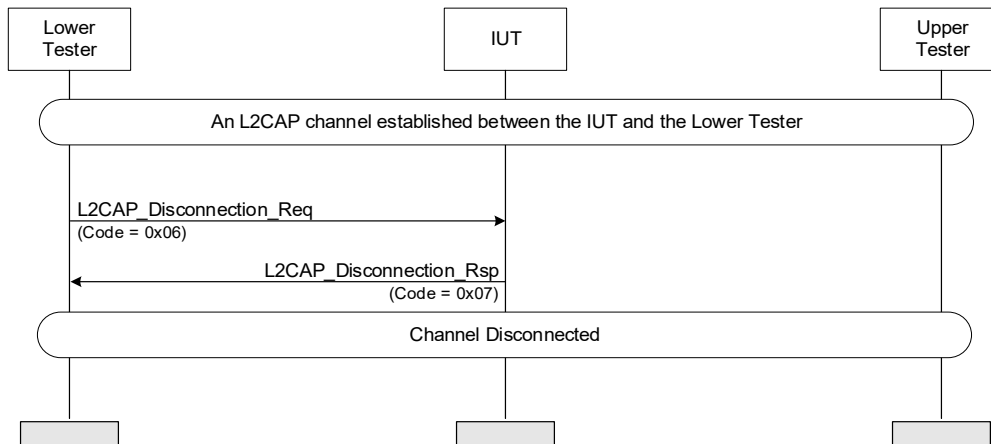

Figure 4.230: Disconnect Response MSC

1. The Lower Tester sends an L2CAP Disconnection Request (Code = 0x06) to the IUT.
2. The IUT sends an L2CAP Disconnection Response (Code = 0x07) to the Lower Tester.

- Expected Outcome

Pass verdict

The IUT responds to the request to disconnect the channel with a correctly formatted L2CAP_DISCONNECTION_RSP.

4.9.3.3 Security – Insufficient Authentication – Initiator

- Test Purpose

Verify that the IUT does not establish any channel upon receipt of an L2CAP LE Credit Based Connection Response / L2CAP Credit Based Connection Response indicating the connections were refused with Result 0x0005 (“All connections refused – insufficient authentication”).

- Initial Condition

- The signaling channel specified in [Table 4.57](#) is used.
- The Upper Tester can command the IUT to create a credit based channel on an SPSM declared via the TSPX_psm_authentication_required IXIT value.

- Test Case Configuration

Test Case ID	Reference	Signaling Channel	Signaling Commands	Result
L2CAP/LE/CFC/BV-10-C [Security – Insufficient Authentication – Initiator]	[12] 4.22	0x0005	L2CAP LE Credit Based Connection Request (Code = 0x14) L2CAP LE Credit Based Connection Response (Code = 0x15)	0x0005 – Connection refused – insufficient authentication
L2CAP/ECFC/BV-10-C [Security – Insufficient Authentication – Initiator, LE]	[13] 4.25	0x0005	L2CAP Credit Based Connection Request (Code = 0x17) L2CAP Credit Based Connection Response (Code = 0x18)	0x0005 – All connections refused – insufficient authentication
L2CAP/ECFC/BV-67-C [Security – Insufficient Authentication – Initiator, BR/EDR]	[13] 4.25	0x0001	L2CAP Credit Based Connection Request (Code = 0x17) L2CAP Credit Based Connection Response (Code = 0x18)	0x0005 – All connections refused – insufficient authentication

Table 4.57: Security – Insufficient Authentication – Initiator test cases



- Test Procedure

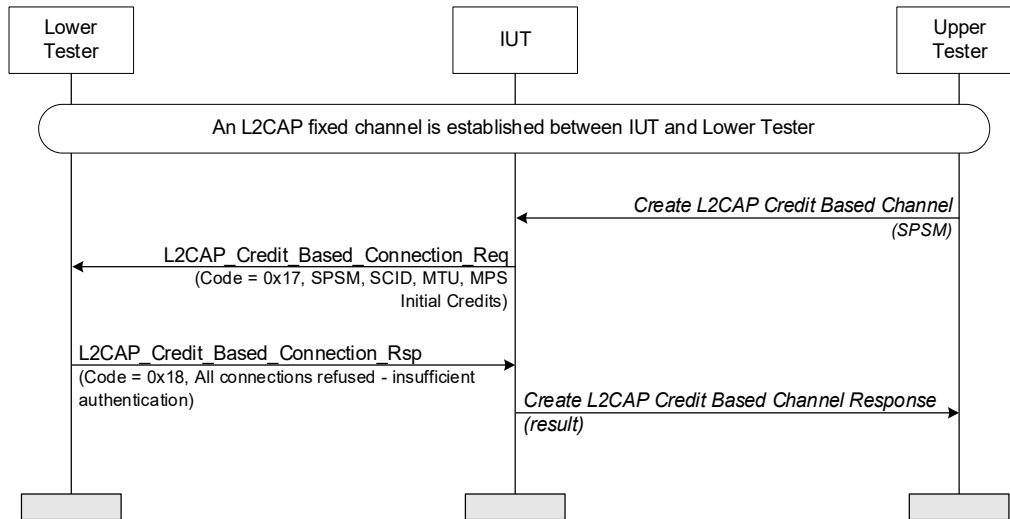

Figure 4.231: Security – Insufficient Authentication – Initiator MSC

- The Upper Tester commands the IUT to send a connection request.
- The IUT sends an L2CAP LE Credit Based Connection Request (Code = 0x14) / L2CAP Credit Based Connection Request (Code = 0x17), as in [Table 4.57](#).
- The Lower Tester sends an L2CAP LE Credit Based Connection Response (Code = 0x15) / L2CAP Credit Based Connection Response (Code = 0x18) with result 0x0005, as in [Table 4.57](#), refusing the channel creation request.

- Expected Outcome

Pass verdict

The IUT informs the Upper Tester about the rejection.

4.9.3.4 Security – Insufficient Authorization – Initiator

- Test Purpose

Verify that the IUT does not establish any channel upon receipt of an L2CAP LE Credit Based Connection Response / L2CAP Credit Based Connection Response indicating the connections were refused with Result 0x0006.

- Initial Condition

- The signaling channel specified in [Table 4.58](#) is used.
- An SPSM for the Enhanced Credit Based Flow Control channel is declared via the TSPX_psm_authorization_required IXIT value.
- The Upper Tester can command the IUT to create a credit based channel on the SPSM declared via the TSPX_psm_authorization_required IXIT value.

- Test Case Configuration

Test Case ID	Reference	Signaling Channel	Signaling Commands	Result
L2CAP/LE/CFC/BV-12-C [Security – Insufficient Authorization – Initiator]	[12] 4.22	0x0005	L2CAP LE Credit Based Connection Request (Code = 0x14) L2CAP LE Credit Based Connection Response (Code = 0x15)	0x0006 – Connection refused – insufficient authorization
L2CAP/ECFC/BV-12-C [Security – Insufficient Authorization – Initiator, LE]	[13] 4.25	0x0005	L2CAP Credit Based Connection Request (Code = 0x17) L2CAP Credit Based Connection Response (Code = 0x18)	0x0006 – All connections refused – insufficient authorization
L2CAP/ECFC/BV-68-C [Security – Insufficient Authorization – Initiator, BR/EDR]	[13] 4.25	0x0001	L2CAP Credit Based Connection Request (Code = 0x17) L2CAP Credit Based Connection Response (Code = 0x18)	0x0006 – All connections refused – insufficient authorization

Table 4.58: Security – Insufficient Authorization – Initiator test cases



- Test Procedure

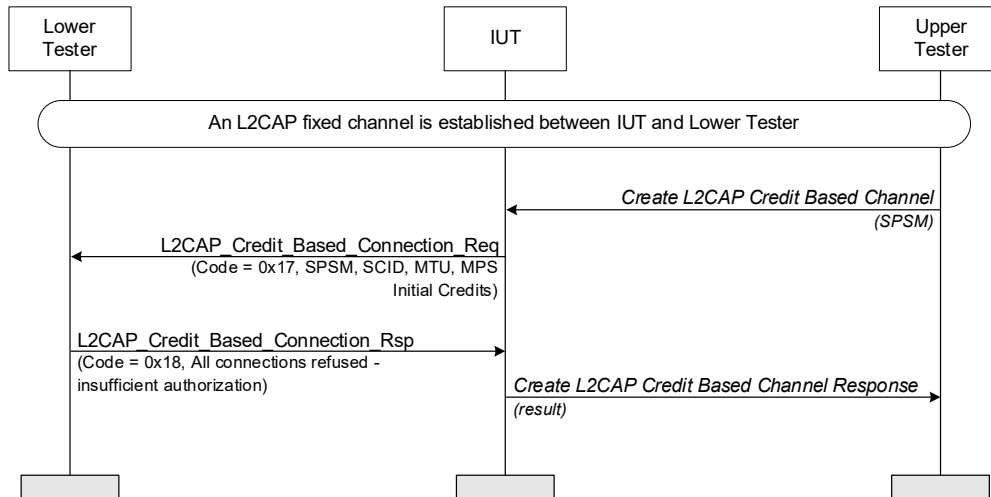

Figure 4.232: Security – Insufficient Authorization – Initiator MSC

1. The Upper Tester commands the IUT to send a connection request.
2. The IUT sends an L2CAP LE Credit Based Connection Request (Code = 0x14) / L2CAP Credit Based Connection Request (Code = 0x17), as in [Table 4.58](#).
3. The Lower Tester sends an L2CAP LE Credit Based Connection Response (Code = 0x15) / L2CAP Credit Based Connection Response (Code = 0x18) with result 0x0006, as in [Table 4.58](#), refusing the connection request.

- Expected Outcome

Pass verdict

The IUT informs the Upper Tester about the rejection.

4.9.3.5 Security – Insufficient Authorization – Responder

- Test Purpose

Verify that an IUT refuses to create any connection upon reception of an L2CAP LE Credit Based Connection Request / L2CAP Credit Based Connection Request which fails to satisfy authorization requirements.

- Initial Condition

- An LE ACL connection is established between the IUT and the Lower Tester.
- An SPSM for the Enhanced Credit Based Flow Control channel is declared via the TSPX_psm_authorization_required IXIT value.
- An authorization requirement exists for the SPSM declared via the TSPX_psm_authorization_required IXIT value.
- No authorization procedure has been performed between the IUT and the Lower Tester.

- Test Case Configuration

Test Case ID	Reference	Signaling Commands	Result
L2CAP/LE/CFC/BV-13-C [Security – Insufficient Authorization – Responder]	[12] 4.22	L2CAP LE Credit Based Connection Request (Code = 0x14) L2CAP LE Credit Based Connection Response (Code = 0x15)	0x0006 – Connection refused – insufficient authorization
L2CAP/ECFC/BV-13-C [Security – Insufficient Authorization – Responder, LE]	[13] 4.25	L2CAP Credit Based Connection Request (Code = 0x17) L2CAP Credit Based Connection Response (Code = 0x18)	0x0006 – All connections refused – insufficient authorization

Table 4.59: Security – Insufficient Authorization – Responder test cases



- Test Procedure

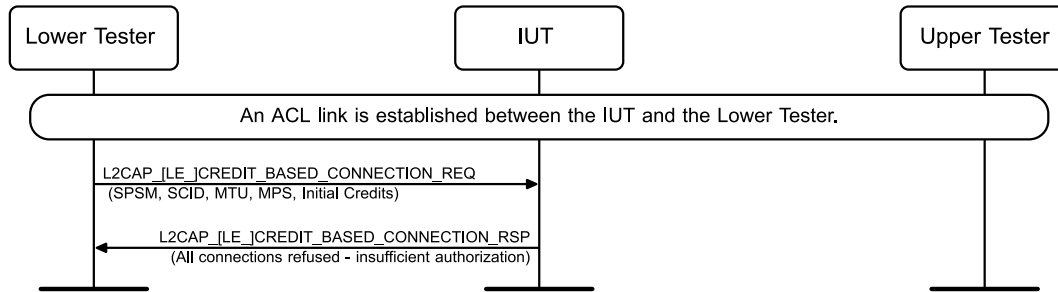

Figure 4.233: Security – Insufficient Authorization – Responder MSC

- The Lower Tester sends an L2CAP LE Credit Based Connection Request (Code = 0x14) / L2CAP Credit Based Connection Request (Code = 0x17).
- The IUT detects the authorization requirement and sends an L2CAP LE Credit Based Connection Response (Code = 0x15) / L2CAP Credit Based Connection Response (Code = 0x18), rejecting the connection request with result 0x0006, as in [Table 4.59](#).

- Expected Outcome

Pass verdict

Upon reception of an L2CAP LE Credit Based Connection Request / L2CAP Credit Based Connection Request from the Lower Tester which fails to satisfy the authorization requirements, the IUT sends a correctly formatted L2CAP LE Credit Based Connection Response / L2CAP Credit Based Connection Response with Result 0x0006 to the Lower Tester.

4.9.3.6 Security – Insufficient Encryption Key Size – Responder

- Test Purpose

Verify that an IUT refuses to create any connection upon receipt of an L2CAP LE Credit Based Connection Request / L2CAP Credit Based Connection Request which fails to satisfy Encryption Key Size requirements.

- Initial Condition

- The signaling channel specified in [Table 4.60](#) is used.
- An SPSM for the Enhanced Credit Based Flow Control channel is declared via the TSPX_psm_encryption_key_size_required IXIT value.
- An encrypted link over the transport is established between the IUT and the Lower Tester. The minimum key size required for the SPSM is declared via the TSPX_Min_Encryption_Key_Length IXIT value. If it is greater than the minimum encryption key size defined by the specification, then the encryption key size used by the Lower Tester is less than the minimum encryption key size, otherwise the Lower Tester uses an encryption key size that is equal to the minimum encryption key size defined by the specification.
- A preamble procedure defined in [Section 4.4.2](#) is used to set up an encrypted link.

- Test Case Configuration

Test Case ID	Reference	Signaling Channel	Signaling Commands	Result
L2CAP/LE/CFC/BV-15-C [Security – Insufficient Encryption Key Size – Responder]	[12] 4.22	0x0005	L2CAP LE Credit Based Connection Request (Code = 0x14) L2CAP LE Credit Based Connection Response (Code = 0x15)	0x0007 – Connection refused – insufficient encryption key size
L2CAP/ECFC/BV-15-C [Security – Insufficient Encryption Key Size – Responder, LE]	[13] 4.25	0x0005	L2CAP Credit Based Connection Request (Code = 0x17) L2CAP Credit Based Connection Response (Code = 0x18)	0x0007 – All connections refused – insufficient encryption key size
L2CAP/ECFC/BV-70-C [Security – Insufficient Encryption Key Size – Responder, BR/EDR]	[13] 4.25	0x0001	L2CAP Credit Based Connection Request (Code = 0x17) L2CAP Credit Based Connection Response (Code = 0x18)	0x0007 – All connections refused – insufficient encryption key size

Table 4.60: Security – Insufficient Encryption Key Size – Responder test cases



- Test Procedure

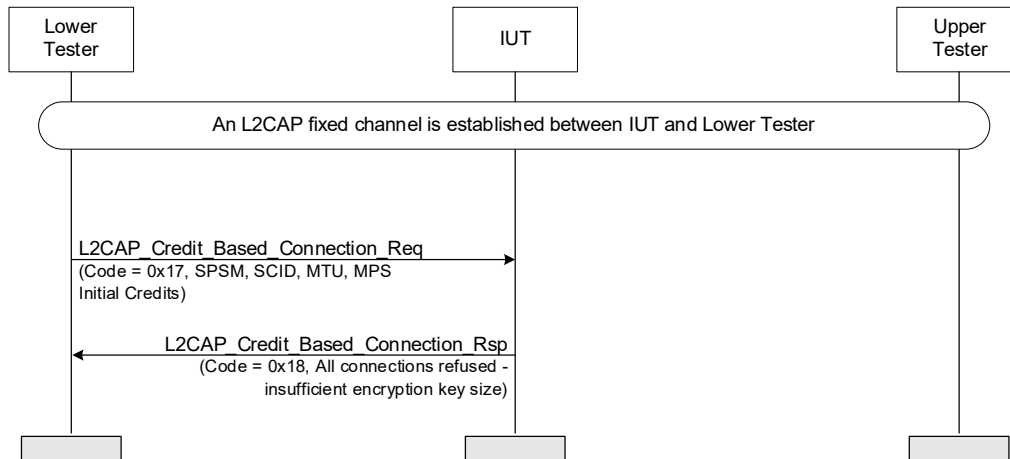

Figure 4.234: Security – Insufficient Encryption Key Size – Responder MSC

- The Lower Tester sends an L2CAP LE Credit Based Connection Request (Code = 0x14) / L2CAP Credit Based Connection Request (Code = 0x17).
- If the minimum encryption key size for the PSM is greater than the minimum encryption key size defined by the specification: ALT 1 is followed and the IUT detects the encryption key size too short for the requirement and sends an L2CAP LE Credit Based Connection Response (Code = 0x15) / L2CAP Credit Based Connection Response (Code = 0x18), rejecting the connection request with Result = 0x0007, as in [Table 4.60](#).
If the minimum encryption key size for the PSM is equal to the minimum encryption key size defined by the specification: ALT 2 is followed, and the connection is successful.

- Expected Outcome

Pass verdict

Upon reception of an L2CAP LE Credit Based Connection Request / L2CAP Credit Based Connection Request from the Lower Tester which fails to satisfy the encryption key size requirements, the IUT sends a correctly formatted L2CAP LE Credit Based Connection Request / L2CAP Credit Based Connection Response with Result 0x0007 to the Lower Tester.

If the minimum encryption key size for the PSM is equal to the minimum encryption key size defined by the specification, the request from the Lower Tester does not fail to satisfy the encryption key size requirement, and the connection is successful.

4.9.3.7 L2CAP Credit Based Connection Request – refused due to insufficient resources

- Test Purpose

Verify that an IUT sending an L2CAP LE Credit Based Connection Request / L2CAP Credit Based Connection Request does not establish some of the requested channels upon receiving an L2CAP LE Credit Based Connection Request / L2CAP Credit Based Connection Response refusing the connection with result 0x0004.

- Initial Condition

- The signaling channel specified in [Table 4.61](#) is used.
- An SPSM for the Enhanced Credit Based Flow Control channel is declared via the TSPX_spsm IXIT value.
- The Upper Tester can command the IUT to create a credit based channel on the SPSM declared via the TSPX_spsm IXIT value.

- Test Case Configuration

Test Case ID	Reference	Signaling Channel	Signaling Commands	Result
L2CAP/LE/CFC/BV-16-C [L2CAP LE Credit Based Connection Request – refused due to insufficient resources]	[12] 4.22	0x0005	L2CAP LE Credit Based Connection Request (Code = 0x14) L2CAP LE Credit Based Connection Response (Code = 0x15)	0x0004 – Connection refused – insufficient resources available
L2CAP/ECFC/BV-16-C [L2CAP Credit Based Connection Request – refused due to insufficient resources, LE]	[13] 4.25	0x0005	L2CAP Credit Based Connection Request (Code = 0x17) L2CAP Credit Based Connection Response (Code = 0x18)	0x0004 – Some connections refused – insufficient resources available
L2CAP/ECFC/BV-71-C [L2CAP Credit Based Connection Request – refused due to insufficient resources, BR/EDR]	[13] 4.25	0x0001	L2CAP Credit Based Connection Request (Code = 0x17) L2CAP Credit Based Connection Response (Code = 0x18)	0x0004 – Some connections refused – insufficient resources available

Table 4.61: L2CAP Credit Based Connection Request – refused due to insufficient resources test cases

• Test Procedure

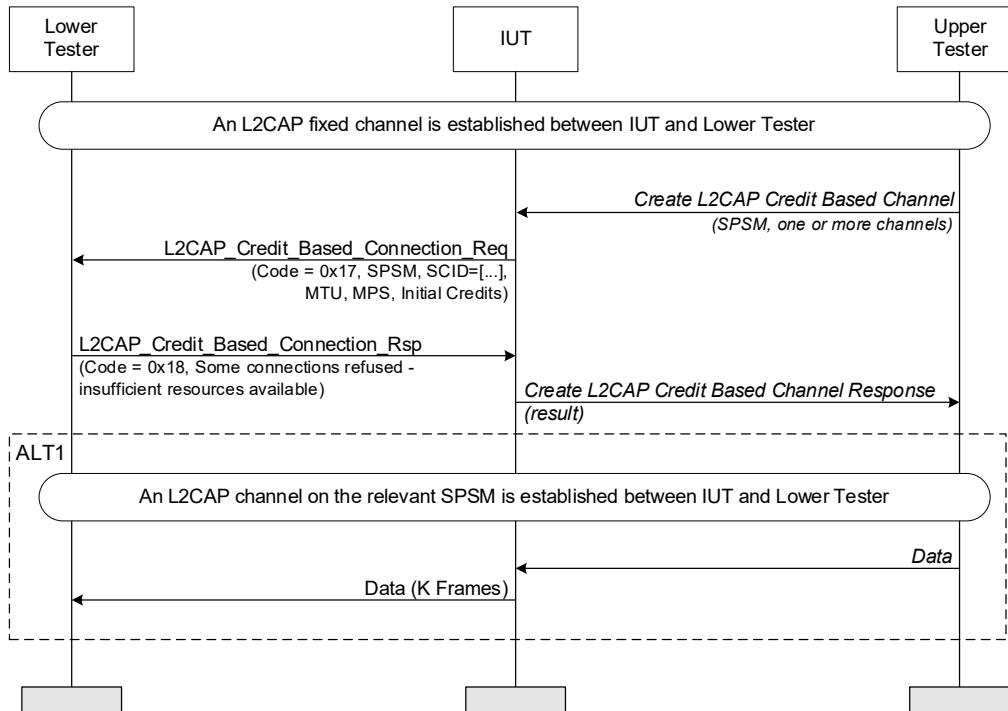

Figure 4.235: L2CAP Credit Based Connection Request – refused due to insufficient resources MSC

1. The Upper Tester commands the IUT to send a connection request.
2. The Lower Tester sends an L2CAP LE Credit Based Connection Response (0x15) / L2CAP Credit Based Connection Response (Code = 0x18) with result 0x0004, as in Table 4.61, refusing the connection request.
3. (ALT1) If run over an Enhanced Credit Based Flow Control channel and the connection request was performed with more than one SCID and some of the channels were created, the Upper Tester commands the IUT to send data on the accepted CIDs.

• Expected Outcome

Pass verdict

The IUT informs the Upper Tester about the rejection.

(ALT1) The data sent by the IUT in Step 3 must be the same as that received by the Lower Tester.

The IUT does not send any data to the Lower Tester on the refused CID(s).

4.9.3.8 L2CAP Credit Based Connection Response on Unsupported SPSM

• Test Purpose

Verify that an IUT receiving L2CAP_CREDIT_BASED_CONNECTION_REQ on an unsupported SPSM responds with L2CAP_CREDIT_BASED_CONNECTION_RSP refusing the connection.

• Initial Condition

- The signaling channel specified in Table 4.62 is used.

- Test Case Configuration

Test Case ID	Reference	Signaling Channel	Result	L2CAP Command
L2CAP/LE/CFC/BV-22-C [L2CAP LE Credit Based Connection Response on Unsupported SPSM]	[13] 4.23	0x0005	0x0002 – Connection refused – SPSM not supported	L2CAP_LE_CREDIT_BASED_CONNECTION_REQ/RSP
L2CAP/ECFC/BV-28-C [L2CAP Credit Based Connection Response on Unsupported SPSM, LE]	[13] 4.26	0x0005	0x0002 – All connections refused – SPSM not supported	L2CAP_CREDIT_BASED_CONNECTION_REQ/RSP
L2CAP/ECFC/BV-72-C [L2CAP Credit Based Connection Response on Unsupported SPSM, BR/EDR]	[13] 4.26	0x0001	0x0002 – All connections refused – SPSM not supported	L2CAP_CREDIT_BASED_CONNECTION_REQ/RSP

Table 4.62: L2CAP Credit Based Connection Response on Unsupported SPSM test cases



- Test Procedure

The L2CAP Credit Based Connection Request/Response commands are specified in [Table 4.62](#).

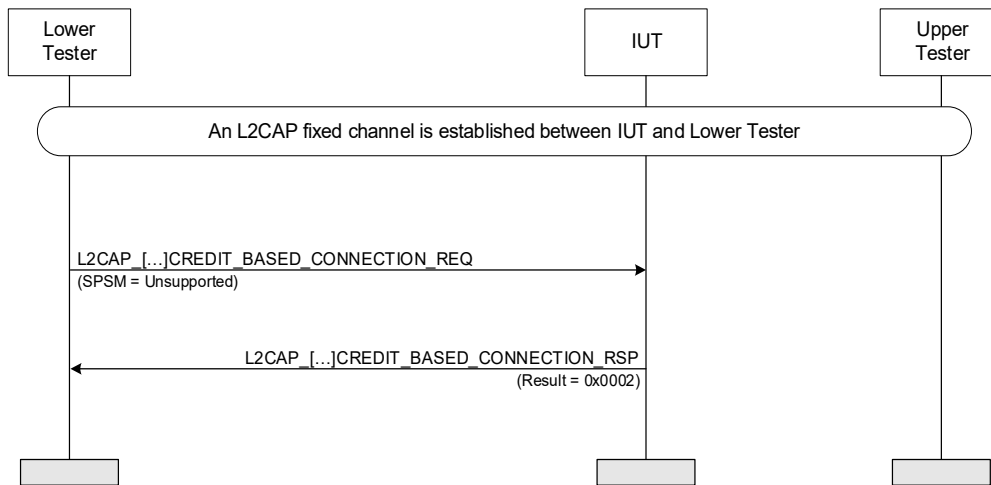

Figure 4.236: L2CAP Credit Based Connection Response on Unsupported SPSM MSC

1. The Lower Tester sends a connection request command on an unsupported SPSM.
2. The IUT responds with a connection request response, with the Result in [Table 4.62](#).

- Expected Outcome

Pass verdict

Upon receiving a connection request command containing an unsupported SPSM, the IUT sends a correctly formatted connection request response to the Lower Tester with the Result in [Table 4.62](#).

4.9.3.9 Disconnect Request – DCID not recognized or fixed channel

- Test Purpose

Verify that an IUT receiving Disconnect Request from the Lower Tester for which the DCID is not recognized by the IUT or is a fixed channel responds with L2CAP_COMMAND_REJECT_RSP with an “invalid CID” result code.

- Reference

[13] 4.1, 4.6

- Initial Condition

- The signaling channel specified in [Table 4.63](#) is used.
- An LE or BR/EDR Data Channel is established on the SPSM declared via the TSPX_spsm IXIT value using the commands specified in [Table 4.63](#).

- Test Case Configuration

Test Case ID	Signaling Channel	L2CAP Command
L2CAP/LE/CFC/BV-23-C [Disconnect Request – DCID not recognized or fixed channel]	0x0005	L2CAP_LE_CREDIT_BASED_CONNECTION_REQ/RSP
L2CAP/ECFC/BV-30-C [Disconnect Response – DCID not recognized or fixed channel, LE]	0x0005	L2CAP_CREDIT_BASED_CONNECTION_REQ/RSP
L2CAP/ECFC/BV-73-C [Disconnect Response – DCID not recognized or fixed channel, BR/EDR]	0x0001	L2CAP_CREDIT_BASED_CONNECTION_REQ/RSP

Table 4.63: Disconnect Request – DCID not recognized or fixed channel test cases



- Test Procedure

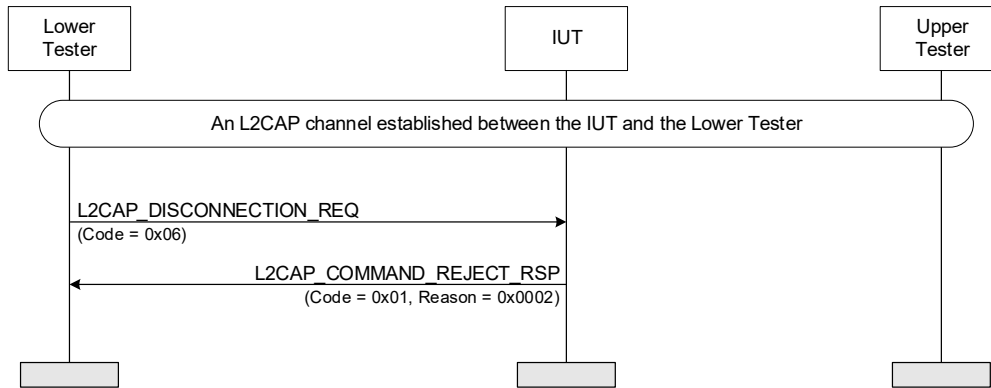

Figure 4.237: Disconnect Request – DCID not recognized or fixed channel MSC

1. The Lower Tester sends an L2CAP_DISCONNECTION_REQ (Code = 0x06) to the IUT on the PSM as specified in Table 4.63, with a DCID not recognized by the IUT.
2. The IUT sends an L2CAP_COMMAND_REJECT_RSP packet (Code = 0x01) to the Lower Tester, with Reason “0x0002 – Invalid CID in request”.
3. The Lower Tester sends an L2CAP_DISCONNECTION_REQ (Code = 0x06) to the IUT on the PSM as specified in Table 4.63, with the CID set to the signaling channel being used.
4. The IUT sends an L2CAP_COMMAND_REJECT_RSP packet (Code = 0x01) to the Lower Tester, with Reason “0x0002 – Invalid CID in request”.

- Expected Outcome

Pass verdict

The IUT responds to the request to disconnect the channel with a correctly formatted L2CAP_COMMAND_REJECT_RSP message.

4.9.3.10 Security – Insufficient Encryption – Initiator

- Test Purpose

Verify that the IUT does not establish any channel upon receipt of an L2CAP_CREDIT_BASED_CONNECTION_RSP indicating that the connections were refused with Result 0x0008 (“All connections refused – insufficient encryption”).

- Initial Condition

- The signaling channel specified in Table 4.64 is used.
- Either an LTK or STK exists between the IUT and the Lower Tester, but encryption is not enabled.
- An SPSM for the Enhanced Credit Based Flow Control channel is declared via the TSPX_spsm IXIT value.

- Test Case Configuration

Test Case ID	Reference	Signaling Channel	Result	L2CAP Command
L2CAP/LE/CFC/BV-24-C [Security – Insufficient Encryption – Initiator]	[13] 4.22	0x0005	0x0008 (“Connection refused – insufficient encryption”)	L2CAP_LE_CREDIT_BASED_CONNECTION_REQ/RSP
L2CAP/ECFC/BV-31-C [Security – Insufficient Encryption – Initiator, LE]	[13] 4.25	0x0005	0x0008 (“All connections refused – insufficient encryption”)	L2CAP_CREDIT_BASED_CONNECTION_REQ/RSP

Table 4.64: Security – Insufficient Encryption – Initiator test cases



- Test Procedure

The L2CAP Credit Based Connection Request/Response commands are specified in [Table 4.64](#).

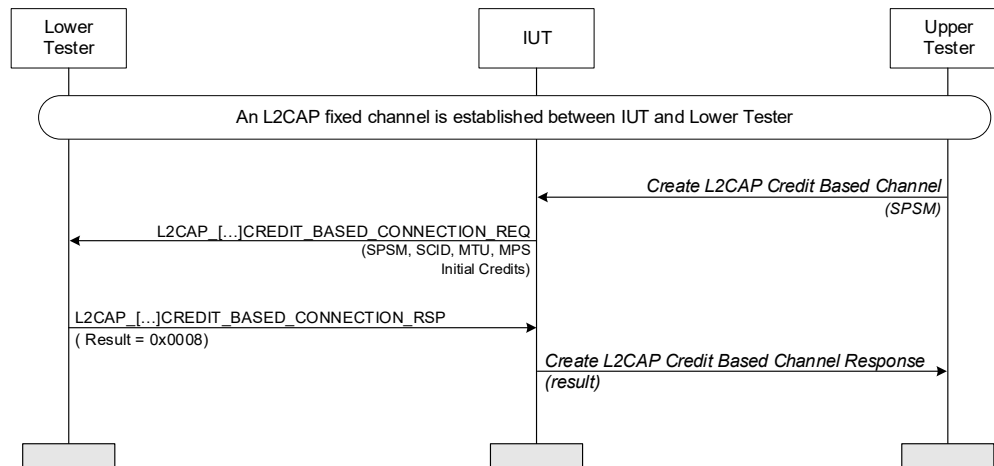

Figure 4.238: Security – Insufficient Encryption – Initiator MSC

1. The Upper Tester commands the IUT to send a connection request on an SPSM as specified in [Table 4.64](#).
2. The IUT sends an L2CAP_CREDIT_BASED_CONNECTION_REQ for the specified SPSM.
3. The Lower Tester sends an L2CAP_CREDIT_BASED_CONNECTION_RSP with Result 0x0008 ([Table 4.64](#)), refusing the channel creation request.

- Expected Outcome

Pass verdict

The IUT informs the Upper Tester about the rejection.

4.9.3.11 Security – Insufficient Encryption – Responder

- Test Purpose

Verify that an IUT refuses to create any connection upon reception of an L2CAP_CREDIT_BASED_CONNECTION_REQ that fails to satisfy encryption requirements.

- Initial Condition

- The signaling channel specified in [Table 4.65](#) is used.
- Either an LTK or STK exists between the IUT and the Lower Tester, but encryption is not enabled.
- An SPSM for the Enhanced Credit Based Flow Control channel is declared via the TSPX_psm_encryption_required IXIT value.
- Encryption requirement exists for the SPSM in use.

- Test Case Configuration

Test Case ID	Reference	Signaling Channel	Result	L2CAP Command
L2CAP/LE/CFC/BV-25-C [Security – Insufficient Encryption – Responder]	[13] 4.22	0x0005	0x0008 (“Connection refused – insufficient encryption”)	L2CAP_LE_CREDIT_BASED_CONNECTION_REQ/RSP
L2CAP/ECFC/BV-32-C [Security – Insufficient Encryption – Responder, LE]	[13] 4.25	0x0005	0x0008 (“All connections refused – insufficient encryption”)	L2CAP_CREDIT_BASED_CONNECTION_REQ/RSP

Table 4.65: Security – Insufficient Encryption – Responder test cases



- Test Procedure

The L2CAP Credit Based Connection Request/Response commands for the test are specified in [Table 4.65](#).

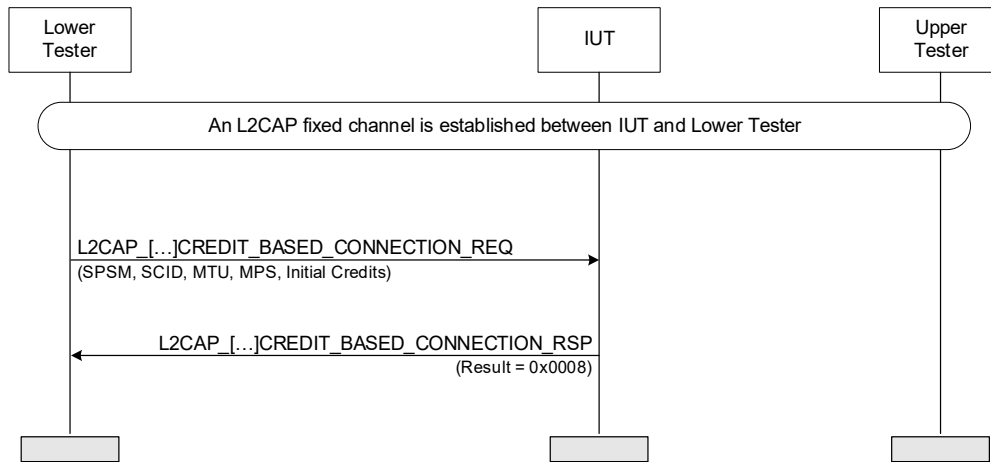

Figure 4.239: Security – Insufficient Encryption – Responder MSC

1. The Lower Tester sends an L2CAP_CREDIT_BASED_CONNECTION_REQ to the IUT for the specified SPSM.
2. The IUT sends an L2CAP_CREDIT_BASED_CONNECTION_RSP to the Lower Tester with Result 0x0008 ([Table 4.65](#)), refusing the channel creation request.

- Expected Outcome

Pass verdict

Upon reception of an L2CAP_CREDIT_BASED_CONNECTION_REQ from the Lower Tester that fails to satisfy the authentication requirements, the IUT sends a correctly formatted L2CAP_CREDIT_BASED_CONNECTION_RSP with Result 0x0008 ([Table 4.65](#)) to the Lower Tester.

4.9.3.12 K-frame – SDU length greater than MTU of IUT

- Test Purpose

Verify that an IUT receiving a K-frame from the Lower Tester with ‘L2CAP SDU Length’ field set to a value greater than the MTU of the IUT on L2CAP Credit Based Channel sends an L2CAP Disconnect Request for that channel.

- Reference

[13] 3.4.3

- Initial Condition

- The signaling channel specified in [Table 4.66](#) is used.
- A Data Channel is established on the SPSM declared via the TSPX_spsm IXIT value using the commands specified in [Table 4.66](#).

- Test Case Configuration

Test Case ID	Signaling Channel	L2CAP Command
L2CAP/LE/CFC/BV-26-C [K-frame – SDU length greater than MTU of IUT]	0x0005	L2CAP_LE_CREDIT_BASED_CONNECTION_REQ/RSP
L2CAP/ECFC/BV-33-C [K-frame – SDU length greater than MTU of IUT, LE]	0x0005	L2CAP_CREDIT_BASED_CONNECTION_REQ/RSP
L2CAP/ECFC/BV-76-C [K-frame – SDU length greater than MTU of IUT, BR/EDR]	0x0001	L2CAP_CREDIT_BASED_CONNECTION_REQ/RSP

Table 4.66: K-frame - SDU length greater than MTU of IUT – test cases



- Test Procedure

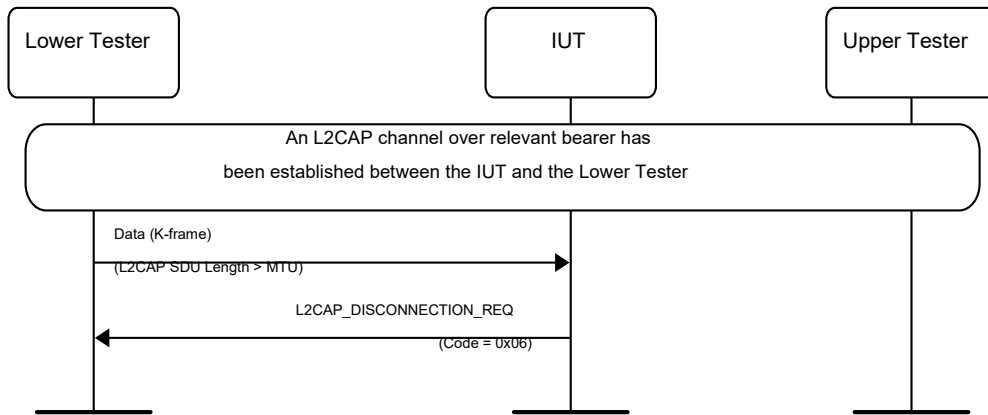

Figure 4.240: K-frame - SDU length greater than MTU of IUT MSC

1. The Lower Tester sends a K-frame to the IUT with 'L2CAP SDU Length' field set to a value greater than the MTU of the IUT on L2CAP Credit Based Channel.

- Expected Outcome

Pass verdict

The IUT terminates the channel and sends a correctly formatted L2CAP_DISCONNECTION_REQ PDU (Code = 0x06) to the Lower Tester.

4.9.3.13 K-frame – Information Payload length greater than MPS of IUT

- Test Purpose

Verify that an IUT receiving a K-frame from the Lower Tester with the length of 'Information Payload' field greater than the MPS of the IUT on L2CAP Credit Based Channel sends an L2CAP Disconnect Request for that channel.

- Reference

[13] 3.4.3

- Initial Condition

- The signaling channel specified in [Table 4.67](#) is used.
- A Data Channel is established on the SPSM declared via the TSPX_spsm IXIT value using the commands specified in [Table 4.67](#).

- Test Case Configuration

Test Case ID	Signaling Channel	L2CAP Command
L2CAP/LE/CFC/BV-27-C [K-frame – Information Payload length greater than MPS of IUT]	0x0005	L2CAP_LE_CREDIT_BASED_CONNECTION_REQ/RSP
L2CAP/ECFC/BV-34-C [K-frame – Information Payload length greater than MPS of IUT, LE]	0x0005	L2CAP_CREDIT_BASED_CONNECTION_REQ/RSP
L2CAP/ECFC/BV-77-C [K-frame – Information Payload length greater than MPS of IUT, BR/EDR]	0x0001	L2CAP_CREDIT_BASED_CONNECTION_REQ/RSP

Table 4.67: K-frame – Information Payload length greater than MPS of IUT test cases



- Test Procedure

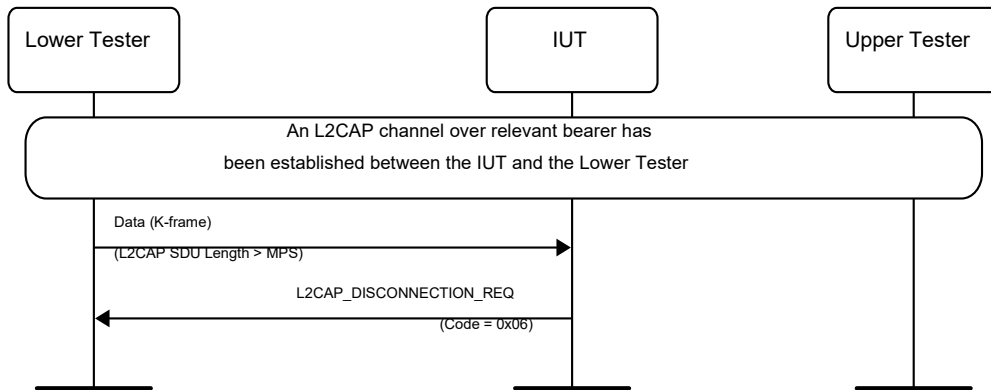

Figure 4.241: K-frame – Information Payload length greater than MPS of IUT MSC

1. The Lower Tester sends a K-frame to the IUT with the length of 'Information Payload' field greater than the MPS of the IUT on L2CAP Credit Based Channel.

- Expected Outcome

Pass verdict

The IUT terminates the channel and sends a correctly formatted L2CAP_DISCONNECTION_REQ PDU (Code = 0x06) to the Lower Tester.

4.9.3.14 Total length of segments greater than SDU length specified in first K-frame

- Test Purpose

Verify that an IUT receiving segmented K-frames from the Lower Tester on L2CAP Credit Based Channel with total length of the segmented payloads greater than 'L2CAP SDU Length' field specified in the first K-frame sends an L2CAP Disconnect Request for that channel.

- Reference

[13] 3.4.3

- Initial Condition

- The signaling channel specified in [Table 4.68](#) is used.
- A Data Channel is established on the SPSM declared via the TSPX_spsm IXIT value.

- Test Case Configuration

Test Case ID	Signaling Channel	L2CAP Command
L2CAP/LE/CFC/BV-28-C [Total length of segments greater than SDU length specified in first K-frame]	0x0005	L2CAP_CREDIT_BASED_CONNECTION_REQ/RSP
L2CAP/ECFC/BV-35-C [Total length of segments greater than SDU length specified in first K-frame, LE]	0x0005	L2CAP_CREDIT_BASED_CONNECTION_REQ/RSP
L2CAP/ECFC/BV-78-C [Total length of segments greater than SDU length specified in first K-frame, BR/EDR]	0x0001	L2CAP_CREDIT_BASED_CONNECTION_REQ/RSP

Table 4.68: Total length of segments greater than SDU length specified in first K-frame test cases



- Test Procedure

Same as for [L2CAP/COS/CFC/BV-03-C \[Reassembling\]](#), but in the last segment, the Lower Tester sends an Information Payload longer (at least one byte) than the correct size, such that the total length of segmented payloads is greater than 'L2CAP SDU Length' field specified in first K-frame.

- Expected Outcome

Pass verdict

The IUT terminates the channel and sends a correctly formatted L2CAP_DISCONNECTION_REQ PDU (Code = 0x06) to the Lower Tester.

4.9.3.15 K-frame – SDU length = MPS

- Test Purpose

Verify that an IUT does not disconnect the peer when the payload size does not exceed the MPS. Verify that the IUT does not use the SDU Length 2 octets into calculating the payload size.

- Reference

[\[13\]](#) 3.4.3

- Initial Condition

- The SPSM for the control channel is declared by the TSPX_spsm IXIT value.

- Test Case Configuration

Test Case ID	Signaling Channel	L2CAP Command
L2CAP/LE/CFC/BV-32-C [K-frame – SDU length = MPS]	0x0005	L2CAP_LE_CREDIT_BASED_CONNECTION_REQ/RSP
L2CAP/ECFC/BV-80-C [K-frame – SDU length = MPS, LE]	0x0005	L2CAP_CREDIT_BASED_CONNECTION_REQ/RSP
L2CAP/ECFC/BV-81-C [K-frame – SDU length = MPS, BR/EDR]	0x0001	L2CAP_CREDIT_BASED_CONNECTION_REQ/RSP

Table 4.69: K-frame – SDU length = MPS test cases



• Test Procedure

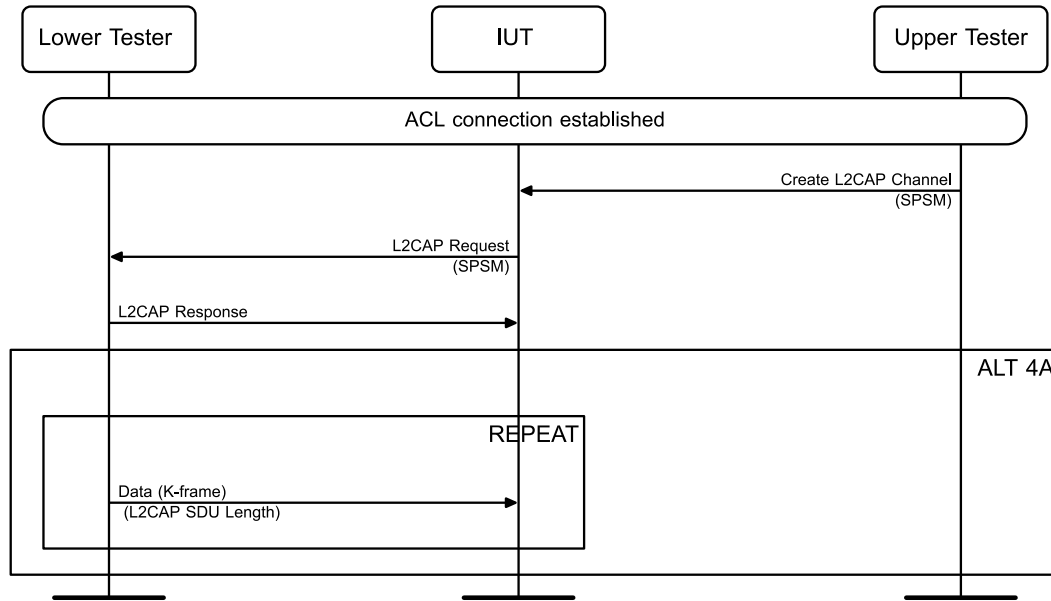

Figure 4.242: K-frame – SDU length = MPS MSC

1. The Upper Tester commands the IUT to create an L2CAP channel using the SPSM set to TSPX_spsm.
2. The IUT sends the L2CAP command request specified in Table 4.69 to the Lower Tester on the SPSM from Step 1. The Lower Tester stores the MTU and MPS.
3. The Lower Tester sends the L2CAP command response specified in Table 4.69 to the IUT.
4. Perform alternative 4A or 4B depending on the MTU sent in Step 2:
 - ALT 4A: The MTU in Step 2 is greater than or equal to the MPS in Step 2 – 1.
 - 4A.1 Repeat Step 4 for all rounds in Table 4.704.71.
 - 4A.2 The Lower Tester sends a K-frame to the IUT with the 'L2CAP SDU Length' field set to the value in Table 4.704.71 with a random payload.
 - ALT 4B: The MTU in Step 2 is less than the MPS in Step 2 – 1:
 - 4B.1 The L2CAP channel is created using MTU less than MPS – 1.

Round	SDU Length
1	MPS
2	MPS – 1
3	MPS + 1
4	MPS x 2
5	MPS x 2 + 1
6	MTU

Table 4.704.71: K-frame – SDU length = MPS rounds

• Expected Outcome

Pass verdict

In Step 4, the IUT does not disconnect the channel created in Step 1.

4.10 Generic Attribute Timing tests

Check that the IUT respects the GATT timings.

4.10.1 Back-off on Connection Request Collision

- Test Purpose

Verify that an IUT in a Peripheral role that initiates an L2CAP connection request and encounters a collision uses an appropriate back-off timer before initiating a retry.

- Reference

[13] 4.3, 4.26

[14] 5.3.2, 5.4

- Initial Condition

- The IUT acts in the Peripheral role.
- For EATT, an encrypted ACL link between the IUT and the Lower Tester is established.
- An L2CAP channel over the transport with the PSM/SPSM is set up as specified in [Table 4.72](#).
- For the tests in [Table 4.72](#) that use EATT as the bearer, the following also apply:
 - The Server Supported Features characteristic is present and states that it supports Enhanced ATT bearers, on both the IUT and Lower Tester sides.
 - $(TSPX_iut_supported_max_channels - 1)$ LE or BR/EDR Data Channels are established on the EATT SPSM (the maximum number of EATT supported channels declared in the IXIT, minus 1).

- Test Case Configuration

Test Case	Transport	Code	PSM/SPSM	Min Back-off
L2CAP/TIM/BV-01-C [Back-off on Connection Request Collision, BR/EDR, Dynamic]	BR/EDR	0x02	ATT	100 ms
L2CAP/TIM/BV-02-C [Back-off on Connection Request Collision, BR/EDR, EATT]	BR/EDR	0x17	EATT	100 ms
L2CAP/TIM/BV-03-C [Back-off on Connection Request Collision, LE, EATT]	LE	0x17	EATT	Max(100 ms, $2 \times (\text{connPeripheralLatency} + 1) \times \text{connInterval}$)

Table 4.72: Back-off on Connection Request Collision test cases



- Test Procedure

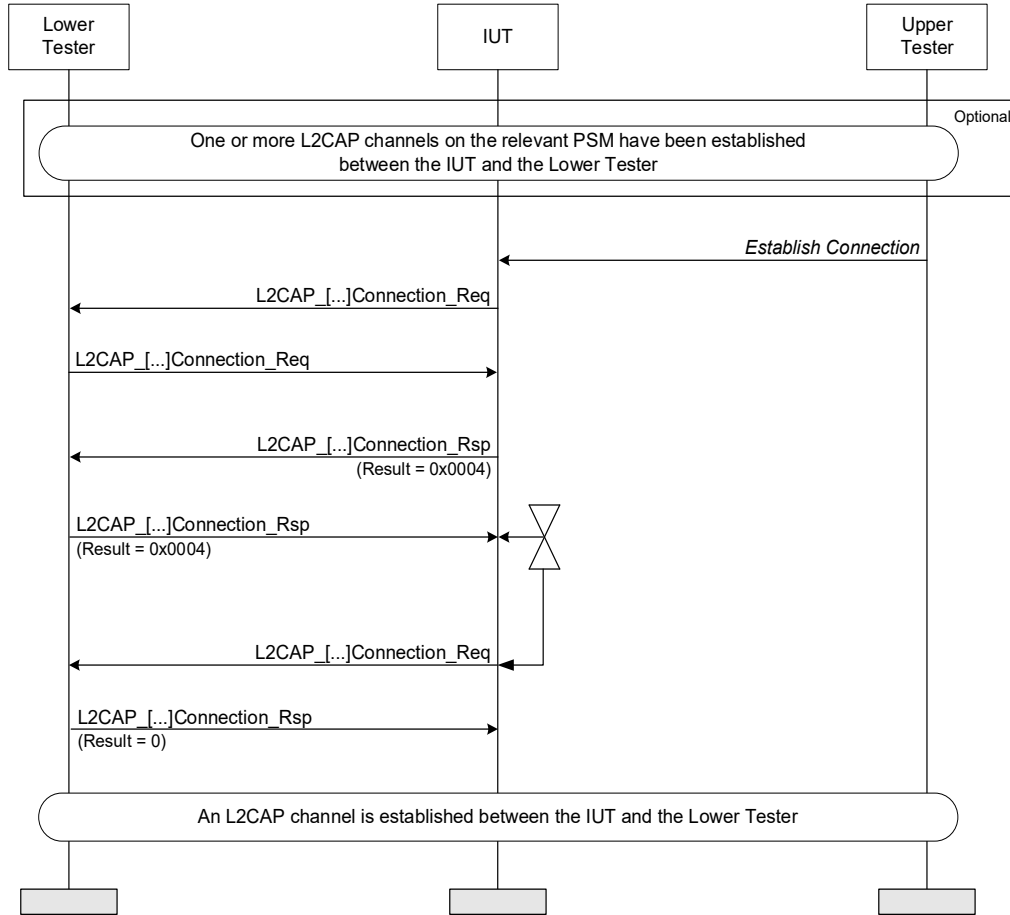

Figure 4.243: Back-off on Connection Request Collision MSC

1. The Upper Tester commands the IUT to establish a connection to the Lower Tester.
2. The IUT sends an L2CAP Connection Request packet to the Lower Tester, in order to establish an L2CAP channel.
3. The Lower Tester sends an L2CAP Connection Request packet to the IUT (code as specified in [Table 4.72](#)).
4. The IUT sends the Lower Tester the response corresponding to the request sent in Step 3 with Result = 0x0004.
5. The Lower Tester sends the IUT the response corresponding to the request sent in Step 2 with Result = 0x0004.
6. The IUT waits for at least the time specified in [Table 4.72](#). The Lower Tester does not send any packet during this time.
7. The IUT sends an L2CAP Connection Request packet to the Lower Tester, to establish an L2CAP channel.
8. The Lower Tester accepts the request, creates an L2CAP channel of the type described in [Table 4.72](#), and responds with an L2CAP Connection Response packet with Result = 0x0000.

- Expected Outcome

Pass verdict

The IUT sends the L2CAP Connection Request to the Lower Tester, in Step 8, after at least the time listed in [Table 4.72](#).

Fail verdict

In Step 4, the IUT accepts the connection request from the Lower Tester and creates an L2CAP channel of the type described in [Table 4.72](#).

- Note

The L2CAP packets exchanged between the IUT and the Lower Tester are of the type corresponding to the transport and bearer in [Table 4.72](#) (L2CAP_CONNECTION_REQ / L2CAP_CONNECTION_RSP and, respectively, L2CAP_CREDIT_BASED_CONNECTION_REQ / L2CAP_CREDIT_BASED_CONNECTION_RSP).

5 Test case mapping

The Test Case Mapping Table (TCMT) maps test cases to specific requirements in the ICS. The IUT is tested in all roles for which support is declared in the ICS document.

The columns for the TCMT are defined as follows:

Item: Contains a logical expression based on specific entries from the associated ICS document. Contains a logical expression (using the operators AND, OR, NOT as needed) based on specific entries from the applicable ICS document(s). The entries are in the form of y/x references, where y corresponds to the table number and x corresponds to the feature number as defined in the ICS document for L2CAP [5].

If a test case is mandatory within the respective layer, then the y/x reference is omitted.

Feature: A brief, informal description of the feature being tested.

Test Case(s): The applicable test case identifiers are required for Bluetooth Qualification if the corresponding y/x references defined in the Item column are supported. Further details about the function of the TCMT are elaborated in [10].

For the purpose and structure of the ICS/IXIT, refer to [10].

Item	Feature	Test Case(s)
L2CAP 2/1	Signaling channel	L2CAP/COS/CED/BV-07-C L2CAP/COS/CED/BV-08-C L2CAP/COS/CED/BV-09-C L2CAP/EXF/BV-08-C L2CAP/FIX/BV-03-C
L2CAP 2/1 AND CORE 2a/63	Signaling channel, peer v4.1 or earlier	L2CAP/COS/CED/BI-30-C
L2CAP 2/1 AND L2CAP 2/41	Reject Unknown Command – BR/EDR	L2CAP/COS/CED/BI-01-C
L2CAP 2/2	Configuration process	L2CAP/COS/CFD/BV-01-C L2CAP/COS/CFD/BV-02-C L2CAP/COS/CFD/BV-03-C L2CAP/COS/CFD/BV-11-C L2CAP/COS/CFD/BV-12-C L2CAP/COS/CFD/BV-14-C
L2CAP 1/7 AND L2CAP 2/2	Configuration process – Initiator	L2CAP/COS/CFD/BV-08-C
L2CAP 2/3	Connection-oriented data channel	L2CAP/COS/CED/BV-03-C L2CAP/COS/CED/BI-04-C L2CAP/COS/CED/BI-06-C L2CAP/COS/CED/BI-07-C L2CAP/COS/CED/BI-08-C L2CAP/COS/CED/BI-10-C L2CAP/COS/CED/BI-12-C L2CAP/COS/CED/BI-14-C L2CAP/COS/CED/BI-15-C L2CAP/COS/CED/BI-28-C

Item	Feature	Test Case(s)
L2CAP 2/3 AND L2CAP 0a/1	Connection-oriented data channel, BR/EDR	L2CAP/COS/CED/BI-03-C
L2CAP 2/45	Send Disconnect Request	L2CAP/COS/CED/BV-04-C
L2CAP 2/4	Command echo request	L2CAP/COS/ECH/BV-02-C
L2CAP 2/5	Echo response	L2CAP/COS/ECH/BV-01-C
L2CAP 2/6	Command information request	L2CAP/COS/IEX/BV-01-C
L2CAP 2/6 AND CORE 2a/63	Command information request, peer v2.1 or earlier	L2CAP/COS/IEX/BI-01-C
L2CAP 2/7	Information response	L2CAP/COS/IEX/BV-02-C L2CAP/EXF/BV-07-C
L2CAP 2/9	Connectionless data channel	L2CAP/CLS/CLR/BV-01-C
L2CAP 2/10	Retransmission Mode	L2CAP/COS/CFD/BV-10-C L2CAP/COS/RTX/BV-01-C L2CAP/COS/RTX/BV-02-C L2CAP/COS/RTX/BV-03-C
L2CAP 2/11	Flow Control Mode	L2CAP/COS/CED/BV-10-C L2CAP/COS/FLC/BV-01-C L2CAP/COS/FLC/BV-02-C L2CAP/COS/FLC/BV-03-C L2CAP/COS/FLC/BV-04-C L2CAP/COS/CFD/BV-13-C
L2CAP 2/12	Enhanced Retransmission Mode	L2CAP/CMC/BV-01-C L2CAP/CMC/BV-02-C L2CAP/ERM/BV-01-C L2CAP/ERM/BV-02-C L2CAP/ERM/BV-03-C L2CAP/ERM/BV-08-C L2CAP/ERM/BV-09-C L2CAP/ERM/BV-10-C L2CAP/ERM/BV-11-C L2CAP/ERM/BV-12-C L2CAP/ERM/BV-18-C L2CAP/ERM/BV-19-C L2CAP/ERM/BV-20-C
L2CAP 2/13	Streaming Mode	L2CAP/CMC/BV-04-C L2CAP/CMC/BV-05-C L2CAP/STM/BV-01-C L2CAP/STM/BV-02-C
L2CAP 2/13 AND L2CAP 2/33 AND L2CAP 2/44	Streaming Mode, STM source over AMP	L2CAP/STM/BV-11-C
L2CAP 2/13 AND L2CAP 2/23 AND L2CAP 2/34 AND L2CAP 2/44	Streaming Mode, Send data using SAR. STM sink over AMP	L2CAP/STM/BV-12-C

Item	Feature	Test Case(s)
L2CAP 2/13 AND L2CAP 2/23 AND L2CAP 2/33 AND L2CAP 2/44	Streaming Mode, Send data using SAR. STM source over AMP	L2CAP/STM/BV-13-C
L2CAP 2/14a	Don't send FCS Option	L2CAP/FOC/BV-06-C L2CAP/FOC/BV-08-C
L2CAP 2/14b	Send FCS Option 0x00	L2CAP/FOC/BV-01-C L2CAP/FOC/BV-02-C L2CAP/FOC/BV-03-C L2CAP/FOC/BV-05-C
L2CAP 2/14c	Send FCS Option 0x01	L2CAP/FOC/BV-04-C L2CAP/FOC/BV-07-C
L2CAP 2/12 AND (L2CAP 2/14a OR L2CAP 2/14c)	ERTM with FCS Option, with FCS	L2CAP/OFS/BV-05-C L2CAP/OFS/BV-06-C
L2CAP 2/12 AND L2CAP 2/14b	ERTM with FCS Option, no FCS	L2CAP/OFS/BV-01-C L2CAP/OFS/BV-02-C
L2CAP 2/13 AND (L2CAP 2/14a OR L2CAP 2/14c)	Streaming with FCS Option, with FCS	L2CAP/OFS/BV-07-C L2CAP/OFS/BV-08-C
L2CAP 2/13 AND L2CAP 2/14b	ERTM with FCS Option, no FCS	L2CAP/OFS/BV-03-C L2CAP/OFS/BV-04-C
L2CAP 2/15	Can Generate Local Busy Condition	L2CAP/ERM/BV-07-C L2CAP/ERM/BV-22-C
L2CAP 2/16	Can Send Reject	L2CAP/ERM/BV-16-C L2CAP/ERM/BI-01-C
L2CAP 2/17	Can Send Selective Reject	L2CAP/ERM/BV-17-C L2CAP/ERM/BI-02-C
L2CAP 2/18	Supports mandatory use of ERTM	L2CAP/CMC/BI-01-C L2CAP/CMC/BI-02-C L2CAP/CMC/BV-12-C
L2CAP 2/19	Supports mandatory use of Streaming Mode	L2CAP/CMC/BI-03-C L2CAP/CMC/BI-04-C L2CAP/CMC/BV-13-C
L2CAP 2/20	Supports optional use of ERTM	L2CAP/CMC/BV-03-C L2CAP/CMC/BV-07-C L2CAP/CMC/BV-10-C
L2CAP 2/21	Supports optional use of Streaming Mode	L2CAP/CMC/BV-06-C L2CAP/CMC/BV-08-C L2CAP/CMC/BV-11-C
L2CAP 2/22	Can send data using SAR in ERTM	L2CAP/ERM/BV-23-C
L2CAP 2/23	Can send data using SAR in Streaming Mode	L2CAP/STM/BV-03-C
L2CAP 2/24	Can actively request Basic Mode for a PSM that supports the use of ERTM or Streaming Mode	L2CAP/CMC/BV-09-C L2CAP/CMC/BI-05-C L2CAP/CMC/BI-06-C

Item	Feature	Test Case(s)
L2CAP 2/25	Supports performing L2CAP channel mode configuration fallback from STM to ERTM	L2CAP/CMC/BV-14-C L2CAP/CMC/BV-15-C
L2CAP 2/26	Supports sending more than one unacknowledged I-frame when operating in ERTM	L2CAP/ERM/BV-05-C L2CAP/ERM/BV-06-C L2CAP/ERM/BV-13-C L2CAP/ERM/BI-03-C L2CAP/ERM/BI-04-C L2CAP/ERM/BI-05-C
L2CAP 2/27	Supports sending more than three unacknowledged I-frames when operating in ERTM	L2CAP/ERM/BV-14-C L2CAP/ERM/BV-15-C
L2CAP 2/38 AND L2CAP 3/14	Extended Flow Specification for ERTM over BR/EDR	L2CAP/LSC/BV-01-C L2CAP/LSC/BV-03-C L2CAP/LSC/BI-04-C
L2CAP 2/38 AND L2CAP 3/15	Extended Flow Specification for STM over BR/EDR	L2CAP/LSC/BV-02-C L2CAP/LSC/BI-05-C L2CAP/LSC/BV-06-C
L2CAP 2/39	Extended Window Size	L2CAP/EWC/BV-01-C L2CAP/EWC/BV-02-C L2CAP/EWC/BV-03-C
L2CAP 2/12 AND L2CAP 2/39	ERTM, EWS and Extended Control Field	L2CAP/ECF/BV-01-C L2CAP/ECF/BV-02-C L2CAP/ECF/BV-03-C L2CAP/ECF/BV-04-C L2CAP/ECF/BV-05-C L2CAP/ECF/BV-06-C L2CAP/ECF/BV-07-C L2CAP/ECF/BV-08-C
L2CAP 3/3 AND L2CAP 1/7	MTU size 48 bytes, Initiator	L2CAP/COS/CFD/BV-09-C L2CAP/COS/CED/BV-01-C
L2CAP 3/3 AND L2CAP 1/8	MTU size 48 bytes, Acceptor	L2CAP/COS/CED/BV-12-C
L2CAP 3/4	MTU size larger than 48 bytes	L2CAP/COS/CED/BV-11-C
L2CAP 2/40	Reject Invalid Command Length, LE	L2CAP/COS/CED/BI-11-C
L2CAP 2/40 AND L2CAP 2/46	Reject Invalid Command Length, LE Credit Based Flow Control Mode	L2CAP/COS/CED/BI-05-C L2CAP/COS/CED/BI-09-C L2CAP/COS/CED/BI-13-C L2CAP/COS/CED/BI-16-C L2CAP/COS/CED/BI-17-C L2CAP/COS/CED/BI-29-C
L2CAP 2/40 AND L2CAP 2/48b AND NOT L2CAP 2/46	Reject Invalid Command Length, Enhanced Credit Based Flow Control Mode – LE	L2CAP/COS/CED/BI-18-C L2CAP/COS/CED/BI-20-C L2CAP/COS/CED/BI-22-C L2CAP/COS/CED/BI-24-C L2CAP/COS/CED/BI-25-C

Item	Feature	Test Case(s)
L2CAP 2/40 AND NOT (L2CAP 2/46 OR L2CAP 2/48b)	Reject Invalid Command Length, LE Credit Based Flow Control and Enhanced Credit Based Flow Control modes not supported – LE	L2CAP/COS/CED/BI-19-C L2CAP/COS/CED/BI-21-C L2CAP/COS/CED/BI-23-C
L2CAP 2/32 AND L2CAP 2/44 AND L2CAP 3/14	ERTM over AMP with Extended Flow Specification – service type “Best Effort”	L2CAP/LSC/BV-07-C L2CAP/LSC/BV-09-C L2CAP/LSC/BI-10-C
L2CAP 2/32 AND L2CAP 2/44 AND L2CAP 3/15	ERTM over AMP with Extended Flow Specification – service type “Guaranteed”	L2CAP/LSC/BI-11-C
L2CAP 2/33 AND L2CAP 2/34 AND L2CAP 2/44 AND L2CAP 3/15	Streaming Mode over AMP with Extended Flow Specification – service type “Guaranteed”	L2CAP/LSC/BV-08-C
L2CAP 2/33 AND L2CAP 2/44 AND L2CAP 3/15	Streaming Mode over AMP with Extended Flow Specification – service type “Guaranteed”	L2CAP/LSC/BV-12-C
L2CAP 2/30	Fixed Channel Support	L2CAP/FIX/BV-01-C
L2CAP 2/30 AND L2CAP 2/31	Fixed Channel and AMP Manager Support	L2CAP/FIX/BV-02-C
L2CAP 2/31 AND L2CAP 2/38	AMP Manager and Extended Flow Specification Support	L2CAP/CCH/BV-01-C L2CAP/CCH/BV-02-C L2CAP/CCH/BV-03-C L2CAP/CCH/BV-04-C
L2CAP 2/32	ERTM over AMP	L2CAP/MCH/BV-01-C L2CAP/MCH/BV-02-C L2CAP/MCH/BV-03-C L2CAP/MCH/BV-04-C L2CAP/MCH/BV-05-C L2CAP/MCH/BV-06-C L2CAP/MCH/BV-07-C L2CAP/MCH/BV-08-C L2CAP/MCH/BV-09-C L2CAP/MCH/BV-10-C L2CAP/MCH/BV-11-C L2CAP/MCH/BV-14-C
L2CAP 2/33	Streaming Mode Source over AMP Support	L2CAP/MCH/BV-15-C L2CAP/MCH/BV-17-C L2CAP/MCH/BV-19-C L2CAP/MCH/BV-21-C L2CAP/MCH/BV-23-C L2CAP/MCH/BV-27-C L2CAP/MCH/BV-29-C L2CAP/MCH/BV-31-C L2CAP/MCH/BV-33-C L2CAP/MCH/BV-35-C

Item	Feature	Test Case(s)
L2CAP 2/34	Streaming Mode Sink over AMP Support	L2CAP/MCH/BV-16-C L2CAP/MCH/BV-18-C L2CAP/MCH/BV-20-C L2CAP/MCH/BV-22-C L2CAP/MCH/BV-24-C L2CAP/MCH/BV-28-C L2CAP/MCH/BV-30-C L2CAP/MCH/BV-32-C L2CAP/MCH/BV-34-C L2CAP/MCH/BV-36-C
L2CAP 2/38 AND L2CAP 2/31		L2CAP/MCH/BV-12-C L2CAP/MCH/BV-13-C L2CAP/MCH/BV-25-C L2CAP/MCH/BV-26-C
L2CAP 2/35	Unicast connectionless data reception	L2CAP/CLS/UCD/BV-01-C L2CAP/CLS/CID/BV-01-C
L2CAP 2/36	Transmission of unencrypted unicast connectionless data	L2CAP/CLS/UCD/BV-02-C
L2CAP 2/37	Transmission of encrypted unicast connectionless data	L2CAP/CLS/UCD/BV-03-C
L2CAP 2/42	Support of Connection Parameter Update Request	L2CAP/LE/CPU/BV-01-C L2CAP/LE/CPU/BI-02-C
L2CAP 2/43	Support of Connection parameter update Response	L2CAP/LE/CPU/BV-02-C L2CAP/LE/CPU/BI-01-C
L2CAP 1/7 AND L2CAP 2/46	LE Credit Based Flow Control Channel Initiator	L2CAP/LE/CFC/BV-01-C L2CAP/LE/CFC/BV-02-C L2CAP/LE/CFC/BV-04-C L2CAP/LE/CFC/BV-16-C L2CAP/LE/CFC/BV-18-C L2CAP/LE/CFC/BV-21-C L2CAP/LE/CFC/BV-22-C L2CAP/LE/CFC/BV-24-C L2CAP/LE/CFC/BV-29-C
L2CAP 1/8 AND L2CAP 2/46	LE Credit Based Flow Control Channel Responder	L2CAP/LE/CFC/BV-03-C L2CAP/LE/CFC/BV-05-C L2CAP/LE/CFC/BV-25-C L2CAP/LE/CFC/BV-30-C
L2CAP 2/40 AND L2CAP 2/41	Reject Unknown Command – LE	L2CAP/LE/REJ/BI-02-C
L2CAP 1/7 AND L2CAP 2/46 AND L2CAP 4/1	LE Credit Based Flow Control Channel Initiator with Authentication	L2CAP/LE/CFC/BV-10-C
L2CAP 1/7 AND L2CAP 2/46 AND L2CAP 4/2	LE Credit Based Flow Control Channel Initiator with Authorization	L2CAP/LE/CFC/BV-12-C

Item	Feature	Test Case(s)
L2CAP 1/7 AND L2CAP 2/46 AND L2CAP 4/3	LE Credit Based Flow Control Channel Initiator with Encryption	L2CAP/LE/CFC/BV-14-C
L2CAP 1/8 AND L2CAP 2/46 AND L2CAP 4/1	LE Credit Based Flow Control Channel Responder with Authentication	L2CAP/LE/CFC/BV-11-C
L2CAP 1/8 AND L2CAP 2/46 AND L2CAP 4/2	LE Credit Based Flow Control Channel Responder with Authorization	L2CAP/LE/CFC/BV-13-C
L2CAP 1/8 AND L2CAP 2/46 AND L2CAP 4/3	LE Credit Based Flow Control Channel Responder with Encryption	L2CAP/LE/CFC/BV-15-C
L2CAP 2/46	LE Credit Based Flow Control Channel - Data	L2CAP/COS/CFC/BV-01-C L2CAP/COS/CFC/BV-02-C L2CAP/COS/CFC/BV-03-C L2CAP/COS/CFC/BV-04-C L2CAP/LE/CFC/BV-06-C L2CAP/LE/CFC/BV-07-C L2CAP/LE/CFC/BI-01-C L2CAP/LE/CFC/BV-09-C L2CAP/LE/CFC/BV-23-C L2CAP/LE/CFC/BV-26-C L2CAP/LE/CFC/BV-27-C L2CAP/LE/CFC/BV-28-C L2CAP/LE/CFC/BV-31-C L2CAP/LE/CFC/BV-32-C
L2CAP 2/46 AND L2CAP 2/45a	LE Credit Based Flow Control Channel – Send Disconnect	L2CAP/LE/CFC/BV-08-C
L2CAP 1/8 AND NOT L2CAP 3/16	Multiple Simultaneous LE Credit Based Flow Control Channels - Reject	L2CAP/LE/CFC/BV-17-C
L2CAP 3/16	Multiple Simultaneous LE Credit Based Flow Control Channels	L2CAP/COS/CFC/BV-05-C
L2CAP 1/7 AND L2CAP 3/16	Connection Request refused due to source CID already allocated - Initiator	L2CAP/LE/CFC/BV-19-C
L2CAP 1/8 AND L2CAP 3/16	Connection Request refused due to source CID already allocated - Responder	L2CAP/LE/CFC/BV-20-C
L2CAP 1/7 AND L2CAP 2/48b	Enhanced Credit Based Flow Control Channel Initiator, LE	L2CAP/ECFC/BV-01-C L2CAP/ECFC/BV-02-C L2CAP/ECFC/BV-04-C L2CAP/ECFC/BV-16-C L2CAP/ECFC/BV-18-C L2CAP/ECFC/BV-19-C L2CAP/ECFC/BV-21-C L2CAP/ECFC/BV-22-C L2CAP/ECFC/BV-24-C L2CAP/ECFC/BV-28-C L2CAP/ECFC/BV-31-C L2CAP/ECFC/BV-38-C

Item	Feature	Test Case(s)
L2CAP 1/7 AND L2CAP 2/48a	Enhanced Credit Based Flow Control Channel Initiator, BR/EDR	L2CAP/ECFC/BV-45-C L2CAP/ECFC/BV-46-C L2CAP/ECFC/BV-48-C L2CAP/ECFC/BV-52-C L2CAP/ECFC/BV-54-C L2CAP/ECFC/BV-55-C L2CAP/ECFC/BV-57-C L2CAP/ECFC/BV-58-C L2CAP/ECFC/BV-60-C L2CAP/ECFC/BV-71-C L2CAP/ECFC/BV-72-C L2CAP/ECFC/BV-79-C
L2CAP 1/8 AND L2CAP 2/48b	Enhanced Credit Based Flow Control Channel Responder, LE	L2CAP/ECFC/BI-03-C L2CAP/ECFC/BI-04-C L2CAP/ECFC/BI-05-C L2CAP/ECFC/BI-06-C L2CAP/ECFC/BI-07-C L2CAP/ECFC/BV-03-C L2CAP/ECFC/BV-15-C L2CAP/ECFC/BV-17-C L2CAP/ECFC/BV-20-C L2CAP/ECFC/BV-23-C L2CAP/ECFC/BV-25-C L2CAP/ECFC/BV-26-C L2CAP/ECFC/BV-27-C L2CAP/ECFC/BV-29-C L2CAP/ECFC/BV-32-C L2CAP/ECFC/BV-39-C
L2CAP 1/8 AND L2CAP 2/48a	Enhanced Credit Based Flow Control Channel Responder – BR/EDR	L2CAP/ECFC/BI-09-C L2CAP/ECFC/BV-40-C L2CAP/ECFC/BV-47-C L2CAP/ECFC/BV-53-C L2CAP/ECFC/BV-56-C L2CAP/ECFC/BV-59-C L2CAP/ECFC/BI-12-C L2CAP/ECFC/BV-61-C L2CAP/ECFC/BI-13-C L2CAP/ECFC/BV-62-C L2CAP/ECFC/BV-63-C L2CAP/ECFC/BI-14-C L2CAP/ECFC/BI-15-C L2CAP/ECFC/BV-64-C L2CAP/ECFC/BI-16-C L2CAP/ECFC/BV-70-C
L2CAP 1/7 AND L2CAP 2/48b AND L2CAP 4/1	Enhanced Credit Based Flow Control Channel Initiator with Authentication, LE	L2CAP/ECFC/BV-10-C

Item	Feature	Test Case(s)
L2CAP 1/7 AND L2CAP 2/48a AND L2CAP 5/1	Enhanced Credit Based Flow Control Channel Initiator with Authentication, BR/EDR	L2CAP/ECFC/BV-67-C
L2CAP 1/7 AND L2CAP 2/48b AND L2CAP 4/2	Enhanced Credit Based Flow Control Channel Initiator with Authorization, LE	L2CAP/ECFC/BV-12-C
L2CAP 1/7 AND L2CAP 2/48a AND L2CAP 5/2	Enhanced Credit Based Flow Control Channel Initiator with Authorization, BR/EDR	L2CAP/ECFC/BV-68-C
L2CAP 1/7 AND L2CAP 2/48b AND L2CAP 4/3	Enhanced Credit Based Flow Control Channel Initiator with Encryption, LE	L2CAP/ECFC/BV-14-C
L2CAP 1/8 AND L2CAP 2/48b AND L2CAP 4/1	Enhanced Credit Based Flow Control Channel Responder with Authentication, LE	L2CAP/ECFC/BV-11-C
L2CAP 1/8 AND L2CAP 2/48b AND L2CAP 4/2	Enhanced Credit Based Flow Control Channel Responder with Authorization, LE	L2CAP/ECFC/BV-13-C
L2CAP 2/48b	Enhanced Credit Based Flow Control Channel - Data, LE	L2CAP/COS/ECFC/BV-01-C L2CAP/COS/ECFC/BV-02-C L2CAP/COS/ECFC/BV-03-C L2CAP/COS/ECFC/BV-04-C L2CAP/ECFC/BI-01-C L2CAP/ECFC/BI-02-C L2CAP/ECFC/BV-06-C L2CAP/ECFC/BV-07-C L2CAP/ECFC/BV-09-C L2CAP/ECFC/BV-30-C L2CAP/ECFC/BV-33-C L2CAP/ECFC/BV-34-C L2CAP/ECFC/BV-35-C L2CAP/ECFC/BV-41-C L2CAP/ECFC/BV-80-C
L2CAP 2/48a	Enhanced Credit Based Flow Control Channel - Data, BR/EDR	L2CAP/ECFC/BV-42-C L2CAP/ECFC/BV-49-C L2CAP/ECFC/BV-50-C L2CAP/ECFC/BI-10-C L2CAP/ECFC/BI-11-C L2CAP/ECFC/BV-66-C L2CAP/ECFC/BV-73-C L2CAP/ECFC/BV-76-C L2CAP/ECFC/BV-77-C L2CAP/ECFC/BV-78-C L2CAP/ECFC/BV-81-C L2CAP/COS/ECFC/BV-05-C L2CAP/COS/ECFC/BV-06-C L2CAP/COS/ECFC/BV-07-C L2CAP/COS/ECFC/BV-08-C



Item	Feature	Test Case(s)
L2CAP 2/48b AND L2CAP 2/45a	Enhanced Credit Based Flow Control Channel – Send Disconnect, LE	L2CAP/ECFC/BV-08-C
L2CAP 2/48a AND L2CAP 2/45	Enhanced Credit Based Flow Control Channel – Send Disconnect, BR/EDR	L2CAP/ECFC/BV-65-C
(GAP 44/1 OR GAP 44/2 OR GAP 45/1 OR GAP 45/2) AND L2CAP 1/7	Initiator - Simultaneous BR/EDR and LE Transports	L2CAP/LE/CID/BV-01-C
(GAP 44/1 OR GAP 44/2 OR GAP 45/1 OR GAP 45/2) AND L2CAP 1/8	Acceptor - Simultaneous BR/EDR and LE Transports	L2CAP/LE/CID/BV-02-C
(GAP 44/1 OR GAP 44/2 OR GAP 45/1 OR GAP 45/2) AND L2CAP 2/48a AND L2CAP 2/48b	Initiator – Simultaneous BR/EDR and LE Transports – Enhanced Credit Based Flow Control Mode	L2CAP/LE/CID/BV-03-C L2CAP/LE/CID/BV-04-C
L2CAP 0a/1	BR/EDR Invalid CID	L2CAP/COS/CID/BI-01-C
L2CAP 0a/2	LE Invalid CID	L2CAP/LE/CID/BI-01-C
(GATT 1a/2 AND GATT 1a/4) AND L2CAP 1/7 AND L2CAP 1/8	L2CAP Collision Mitigation, BR/EDR, ATT	L2CAP/TIM/BV-01-C
(GATT 1a/2 AND GATT 1a/4) AND L2CAP 1/7 AND L2CAP 1/8 AND L2CAP 2/48a AND GATT 2/3b	L2CAP Collision Mitigation, BR/EDR, EATT	L2CAP/TIM/BV-02-C
(GATT 1a/1 AND GATT 1a/3) AND L2CAP 1/7 AND L2CAP 1/8 AND L2CAP 2/48b AND GATT 2/3a	L2CAP Collision Mitigation, LE, EATT	L2CAP/TIM/BV-03-C

Table 5.1 Test case mapping

6 Revision history and acknowledgments

Revision History

Publication Number	Revision Number	Date	Comments
	D5r3	2003-11-05	Original Release
	D10R00	2004-03-03	Re-partitioned to match Main Specification Volume/Part partitioning. TSE 472, 473, 474, 475, 476, 477, 478, 482, and 485 incorporated
	D12r01-02	2004-03-23	Editorial changes. Changed reference and document numbering to D12 to reflect applicable Bluetooth version.
0	1.2.1	2004-03-25	Editorial changes. Changed document numbering and revision number to conform to legacy system.
1	1.2.2	2004-07-01	Changed page numbering to begin part with page 1 and made editorial changes to accommodate Vol. 1, Part A.
2	1.2.3	2004-08-24	TSE 549 affecting TP/COS/CED/BV-01-C TSE 554 affecting the TCMT TSE 576 affecting TP/COS/IEX/BV-02-C TSE 611 affecting TP/COS/CED/BV-08-C
3	1.2.4	2005-03-23	TSE 564 : TP/COS/CFD/BV-09-C. TSE 595 : TCMT. TSE 597 : TP/COS/RTX/BV-01-C. TSE 602 : TP/COS/CED/BV-10-C. TSE 630 : TP/COS/ECH/BV-02-C. TSE 635 : TP/COS/CFD/BV-02-C. TSE 637 : TP/COS/CFD/BV-03-C. TSE 698 : TP/COS/CED/BV-08-C.
4	1.2.5	2005-10-21	TSE 746 : TP/COS/CED/BV-08-C; change timer value TSE 790 : TP/COS/CFD/BV-11-C TSE 816 : TP/CLS/GRH/BV03 :04-C TSE 817 : TP/COS/CFD/BV-09: update MSC TSE 791 : TP/COS/CFD/BV-01 Removed all references to GRH, including an entry in the table in 5.1.2, line in the test mapping table. TSE 746: Update TP/COS/CED/BV-08-C per last TSE comment
5	1.2.6	2006-06-05	TSE 851: TP/COS/CED/BV-11-C: add note to P/F verdicts TSE 870: TP/COS/CED.BV-10-C Change MMI to Upper Tester in Pass verdict --Removed Inconclusive verdicts and Uncertainties with 'N/A.'
6	1.2.7	2006-10-06	Update TCMT for TP/COS/CFD/BV-09-C Added new TC TP/COS/CFD/BV-13 TSE 1728: TP/COS/RTX/BV-01-C

Publication Number	Revision Number	Date	Comments
			TSE 1834: Remove stmt "The Lower Tester acts as a device..." Added sentence The Lower Tester utilizes version 1.2 Basic Mode. TP/COS/CED/BV-01-C, TP/COS/CED/BV-03-C, TP/COS/CED/BV-04-C, TP/COS/CED/BV-05-C, TP/COS/CED/BV-07-C, TP/COS/CED/BV-08-C, TP/COS/CFD/BV-02-C, TP/COS/CFD/BV-03-C, TP/COS/CFD/BV-08-C, TP/COS/ECH/BV-01-C, TP/COS/ECH/BV-02-C, TP/CLS/CLR/BV-01-C
7	2.1.E.0	2006-12-28	Removed page numbers as part of references TSE: 1437: TP/COS/CFD/BV-09-C: Remove 3rd L2CAP_CONFIGURATION_REQ in MSC TSE 2012: TP/COS/CFD/BV-09-C: MSC: Make last payload optional.
8	2.1.E.1	2007-08-23	TSE 1987: TP/COS/CFD/BV-01-C; Fail verdict and MSC
9	2.1.E.2	2008-04-18	TSE 2220: TP/COS/CFD/BV-09-C: TP, Pass verdict, fail verdict
10	2.1.E.3	2008-04-19	Add new test cases for enhanced L2CAP
	21.E.4r0	2008-10-08	TSE 2431: TP/COS/CFD/BV-09-C, MSC, pass verdict TSE 2583: TP/COS/CFD/BV-01-C graphic replaced.
11	21.E.4	2008-12-12	Prepare for publication.
	2.1.E.5r0	2009-02-20	Incorporate Unicast connectionless data test cases and new L2CAP test case.
12	3.0.H.0/ 2.1.E.5	2009-04-14	Prepare for publication.
13	3.0.H.1	2009-08-16	TSE 2741: TP/ERM/BV-07-C MSC update TSE 2756: TP/ERM/BV-19-C MSC update to I-frame TSE 2758: TP/ERM/BV-16-C, TP/ERM/BV-17-C, TP/ERM/BI-02-C, TP/ERM/BI-01-C: MSC update to S-frame TSE 2759: TP/ERM/BV-02-C: update MSC init. condition TSE 2787: TP/CMC/BV-04-C: Pass verdict TSE 2785: Update caption for TP/CMC/BV-02-C TSE 2662: TP/ERM/BV-06-C: Updated MSC.
14	3.0.H.2r0	2010-04-16	TSE 3463: TP/ERM/BI-05-C: Updated MSC.
	4.0.0d1 to 4.0.0d5	2010-05-10 to 2010-06-23	Merged document with L2CAP TS for LE Adding the following TCs for LE operation TP/LE/CPU/BV-01-C, TP/LE/CPU/BI-02-C, TP/LE/CPU/BV-02-C, TP/LE/CPU/BV-01-C, TP/LE/REJ/BI-01-C Updated TCMT to map with first L2CAP.ICS merged version (L2CAP.ICS.4.0.0d1) BTI review feedback addressed TP/LE/CPU/BV-02-C in verdict L2CAP_ConnecionParametertRsp changed to L2CAP_ConnectionParameterUpdateRsp

Publication Number	Revision Number	Date	Comments
			<p>Figure 4.1 obsolete, removed Sections 5.2.1.1, 5.2.2.1, 5.2.4.1, 5.4.1.1, 5.2.1.11 removed as they repeated what is once defined in 4.4.2 Updated Conformance (section 4.2.6) TSE 3490, labeling of MSC figure 5.111 corrected. TSE 2778 initial condition for TP/COS/ECH/BV-02-C corrected TSE 3059 Test purpose of TP/MCH/BV-30-C corrected TSE 3061 Test purpose of TP/MCH/BV-32-C corrected TSE 3066 Test purpose of TP/MCH/BV-33-C corrected TSE 3067 Test purpose of TP/MCH/BV-34-C corrected TSE 3130 Pass verdicts of corrected TSE 3223 Updated fail verdicts for TP/CMC/BV-09-C and , TP/CMC/BI-05-C TSE 3225 Re-added missing Figure 5.73 in TP/ERM/BV-03-C TSE 3305 Corrected TCMT for missing TP/CCH/BV-02-C and TP/CCH/BV-03-C. TSE 3344 Corrected TCMT for TP/OFS/BV-01-C, TP/OFS/BV-02-C, TP/OFS/BV-05-C TP/OFS/BV-06-C (L2CAP, 2/12 AND 2/14) TP/OFS/BV-03-C TP/OFS/BV-04-C TP/OFS/BV-07-C TP/OFS/BV-08-C (L2CAP, 2/13 AND 2/14) TSE 3799 addressing duplicate TC-identifiers, second instance of TP/STM/BV-01-C and TP/STM/BV-02-C, renamed to TP/STM/BV-11-C and TP/STM/BV-12-C. New TCMT for TP/STM/BV-11-C, TP/STM/BV-12-C and TP/STM/BV-13-C TSE 3422 updated TCMT for TP/LSC/BV-07-C, TP/LSC/BV-09-C, TP/LSC/BI-10-C, TP/LSC/BI-11-C, TP/LSC/BV-08-C, TP/LSC/BV-12-C TSE 3805 editorial note in TP/LSC/BV-08-C test purpose removed TSE 3804 editorial note in TP/LSC/BV-02-C test purpose removed TSE 3803 editorial note in TP/EXF/BV-05-C fail verdict removed TSE 2980 IUT role clarified in initial conditions for TP/COS/CFD/BV-09-C, TP/COS/ECH/BV-02-C, TP/COS/CED/BV-11-C, TP/COS/CFD/BV-11-C, TP/COS/CFD/BV-12-C TSE 3382 TCMT corrected for TP/MCH/BV-25-C and TP/MCH/BV-26-C Editorial corrections TSE 3130 edits backed out</p>
15	4.0.0	2010-06-30	Publication.



Publication Number	Revision Number	Date	Comments
	4.0.1r0	2010-11-01 – 2010-11-30	<p>TSE 2734: TP/CMC/BV-03-C:Update MSC</p> <p>TSE 2942: TP/CMC/BV-03-C, TP/CMC/BV-06-C, TP/CMC/BV-07-C, TP/CMC/BV-08-C, TP/CMC/BV-09-C,TP/CMC/BI-05-C, TP/CMC/BI-06-C, TP/CMC/BV-10-C, TP/CMC/BV-11-C: update MSC</p> <p>TSE 3052: TP/MCH/BV-03-C: update MSC</p> <p>TSE 3057: TP/ERM/BV-21-C: update MSC</p> <p>TSE 3070: TP/MCH/BV-36-C: update MCS</p> <p>TSE 3109: TP/ERM/BV-21-C; updated MSC</p> <p>TSE 3293: TP/LSC/BV-06-C, TP/LSC/BV-12-C: update MSC.</p> <p>TSE 3463: TP/ERM/BI-05-C: updated MSC (redone)</p> <p>TSE 3475: TP/ERM/BV-02-C: specify 48-byte MTU</p> <p>TSE 3539: TP/ERM/BV-19-C: updated MSC</p> <p>TSE 3714: TP/CMC/BV-12-C, TP/CMC/BV-13-C</p> <p>TSE 3731: TP/FOC/BV-04-C: Revised test procedure</p> <p>TSE 4079: TP/CMC/BV-03-C - 09-C, TP/CMC/BI-01 - 06-C, TP/CMC/BV-14,15-C, TP/FOC/BV-01 - 03-C, TP/EWC/BV-01-C, TP/EWC/BV-02-C: Change Preamble in MSCs</p> <p>TSE 4082: TP/LE/CPU/BI-01-C: TCMT: add entry</p> <p>TSE 4164: TP/LE/CPU/BI-02-C: fix typos</p>
	4.0.1r1-r6	2011-01-31-2011-05-11	<p>Input reviewer's comments,</p> <p>TSE 3475: TP/ER/BV-02-C: edit MSC Figure 5.72</p> <p>TSE 3714: TP/CMC/BV-12-C, TP/CMC/BV-13-C:edit text per change tracking</p> <p>TSE 3731: TP/FOC/BV-04-C: edited text per change tracking</p> <p>TSE 4079: Edit MSC preambles in the following figures: Fig. 5.43 - 5.51 and Fig 5.57-Fig 5.62, & Fig. 5.107 for TP/CMC/BV-06-C to TP/CMC/BV-09-C, TP/CMC/BI-01-C to TP/CMC/BI-04-C, TP/CMC/BI-06-C, TP/CMC/BV-14-C, TP/CMC/BV-15-C, TP/FOC/BV-01-C to TP/FOC/BV-04-C, and TP/EWC/BV-02-C</p> <p>TSE 4164: Changed wording per change tracking.</p> <p>TSE 4038: TCMT: add selection expressions for TP/EXF/BV-04-C, TP/EXF/BV-05-C, TP/EXF/BV-06-C, TP/EWC/BV-01-C, TP/EWC/BV-02-C, TP/EWC/BV-03-C, TP/LSC/BV-01-C , TP/LSC/BV-02-C , TP/LSC/BV-03-C , TP/LSC/BI-04-C , TP/LSC/BI-05-C , TP/LSC/BV-06-C , TP/ECF/BV-01-C , TP/ECF/BV-02-C , TP/ECF/BV-03-C , TP/ECF/BV-04-C , TP/ECF/BV-05-C , TP/ECF/BV-06-C , TP/ECF/BV-07-C , TP/ECF/BV-08-C</p> <p>More review comments:</p> <p>TSE 3714: TP/CMC/BV-13-C: Pass verdict update</p> <p>TSE 3731: TP/FOC/BV-04-C: typo in MSC</p>

Publication Number	Revision Number	Date	Comments
			TSE 4079: Fig. 5.43 - 5.52 and Fig 5.57-Fig 5.62, & Fig. 5.107 for TP/CMC/BV-06-C to TP/CMC/BV-09-C, TP/CMC/BI-01-C to TP/CMC/BI-04-C, TP/CMC/BI-06-C, TP/CMC/BV-14-C, TP/CMC/BV-15-C, TP/FOC/BV-01-C to TP/FOC/BV-04-C, and TP/EWC/BV-02-C TSE 4164: MSC and Pass verdict edits for all, additional corrections for TP/LE/CPU/BI-01-C, TP/LE/CPU/BI-02-C Further revisions to Figs 5.43-5.52, 5.57-5.61, 5.107: Change "sub-state" to "state" Edit TSE 4164: TP/LE/CPU/BV-01-C and TP/LE/CPU/BV-02-C change Request to Req in MSCs TSE 4192, TSE 4367 TCMT for TP/FIX/BV-02-C
16	4.0.1	2011-07-15	Prepare for publication.
	4.0.2r0	2011-11-07	TSE 3490: Correct MSC figure 5.111 label. Done in 4.0.1 TSE 4073: TP/MCH/BV-12-C, TP/MCH/BV-13-C TCMT change TSE 4279: TP/MCH/BV-26-C: TCMT change per TSE 3382. TSE 4341: TP/CMC/BI-03-C: Remove in TCMT TSE 4373: TP/ERM/BV-21-C: Initial Condition, Pass verdict, Fail verdict TSE 3422, ID: 9030: Fixed TP/LSC/BV-07-C, TP/LSC/BV-08-C, TP/LSC/BV-09-C, TP/LSC/BI-10-C, TP/LSC/BI-11-C, TP/LSC/BI-11-C in TCMT TSE 4398: TP/CCH/BV-01-C, TP/CCH/BV-02-C, TP/CCH/BV-03-C, TP/CCH/BV-04-C: TP/MCH/BV-01-C, TP/MCH/BV-06-C, TP/MCH/BV-04-C, TP/MCH/BV-08-C, TP/MCH/BV-10-C, TP/MCH/BV-12-C: update TCMT TSE 4486: TP/STM/BV-11-C, TP/STM/BV-12-C, TP/STM/BV-13-C: Add to TCMT TSE 4509: TP/ERM/BV-19-C: Update MSC and Pass verdict TSE 4530: TP/OFS/BV-08-C: Update MSC TSE 4548: TP/EXF/BV-05-C: Pass verdict TSE 4562: TP/LE/REJ/BI-01-C: TCMT
17	4.0.2r1	2012-01-24	From JN's review; changes to TCMT for 4073 TSE 4584: Clarification of TSE 3422/Rejection of TSE 4378
	4.0.3r0	2012-09-20	TSE 4817: Update to MSC for TP/ERM/BI-05-C TSE 4811: Update to MSC for TP/ERM/BV-19-C
18	4.0.3	2012-11-12	Prepare for Publication
	4.0.4r1	2013-05-31	TSE 4839: Updated initial condition, pass and fail verdict, and MSC for TP/COS/CED/BV-09-C. Updated TCMT mapping for TP/COS/CFD/BV-09-C and TP/COS/CED/BV-01-C to add "AND L2CAP 1/1" and remove TP/COS/CED/BV-05-C.

Publication Number	Revision Number	Date	Comments
			Added TP/COS/CED/BV-05-C to TCMT in a new row. TSE 5027: Updated purpose, initial condition, MSC and pass and fail verdicts for TP/ERM/BV-21-C.
	4.0.4r2	2013-06-08	BTI Review, Alicia and Magnus: Re-organized items ins 4 and 5 to align with the current template for Test Suite Structure/Test Strategy and Test Purposes. Added the test naming for the LE test groups in the TP naming conventions. Regrouped the test cases in the Test Spec according to the main groupings - CONNECTION ORIENTED basic L2CAP mode; CONNECTION ORIENTED retransmission/flow control/streaming modes; CONNECTIONLESS basic L2CAP mode. Applied some heading styles tos as needed. Added missing test group objectives. Regrouped the tests in the TCMT for the test groups. Added missing features to the TCMT rows. Corrected some type-o's consistently applied Lower Tester and Upper Tester and result codes as well as other test naming/spelling capitalization conventions per the L2CAP specification. Inserted reference tags and updated fields in the test case text. Regenerated the Table of Contents.
	4.0.4r3	2013-06-10	BTI review, Magnus: TSE 4839 TCMT changes were not included originally. Updated.
	4.0.4r1	2013-05-31	TSE 4839: Updated initial condition, pass and fail verdict, and MSC for TP/COS/CED/BV-09-C. Updated TCMT mapping for TP/COS/CFD/BV-09-C and TP/COS/CED/BV-01-C to add "AND L2CAP 1/1" and remove TP/COS/CED/BV-05-C. Added TP/COS/CED/BV-05-C to TCMT in a new row. TSE 5027: Updated purpose, initial condition, MSC and pass and fail verdicts for TP/ERM/BV-21-C.
	4.0.4r2	2013-06-08	BTI Review, Alicia and Magnus: Re-organized items ins 4 and 5 to align with the current template for Test Suite Structure/Test Strategy and Test Purposes. Added the test naming for the LE test groups in the TP naming conventions. Regrouped the test cases in the Test Spec according to the main groupings - CONNECTION ORIENTED basic L2CAP mode; CONNECTION ORIENTED retransmission/flow control/streaming modes; CONNECTIONLESS basic L2CAP mode. Applied some heading styles tos as needed. Added missing test group objectives.

Publication Number	Revision Number	Date	Comments
			Regrouped the tests in the TCMT for the test groups. Added missing features to the TCMT rows. Corrected some type-o's consistently applied Lower Tester and Upper Tester and result codes as well as other test naming/spelling capitalization conventions per the L2CAP specification. Inserted reference tags and updated fields in the test case text. Regenerated the Table of Contents.
	4.0.4r3	2013-06-10	BTI review, Magnus: TSE 4839 TCMT changes were not included originally. Updated.
19	4.0.4	2013-07-02	Prepare for Publication
	4.0.5rT	2013-07-03	Template Conversion: - Update of language to match BTI approved wording (example, fail verdicts) - Removal of Test Subgroup Objectives - Removal of s marked "N/A"
	4.0.5rTr3	2013-08-01	Updated MSC per TSE 1662 in TP/COS/CFD/BV-11-C.
	4.0.5rTr4	2013-10-03	Template Conversion Finalization - Fail Verdicts Removed - New Pass/Fail Verdict Criteria added - Definitions/Abbreviations removed, added to References preamble.
	4.0.5rTr5	2013-10-03	Template Review Comment Resolution & Changes Accepted
	4.1.0r01	2013-10-07	TSE 4840: Updated Initial Condition, MSC and Pass Verdict for TP/COS/CED/BV-08-C and updated TCMT for TP/COS/CED/BV-04-C. TSE 5244: Updated MSC and Pass Verdict for TP/FOC/BV-04-C. TSE 5291: Updated MSCs so the F-bit equals 0 for the I-Frame in ALT 2 of TP/FOC/BV-01-C, TP/FOC/BV-02-C, and TP/FOC/BV-03-C.
	4.1.0r02	2013-10-11	LE L2CAP Connection Oriented Channels CR
	4.1.0r03	2013-10-31	Erratum 5392: Addition of two new test cases, TP/LE/CID/BV-01-C and TP/LE/CID/BV-02-C.
20	4.1.0	2013-12-03	Prepare for Publication
	4.1.1r00	2014-01-23	TSE 5406: Removed duplicates in TCMT for TP/LE/CFC/BV-08-C, TP/MCH/BV-01-C, TP/MCH/BV-04-C, TP/MCH/BV-06-C, TP/MCH/BV-10-C, and TP/MCH/BV-12-C.
	4.1.1r01	2014-04-08	TSE 5371: Revision in MCH for Initial Conditions and Test Procedures to clarify MSCs. TSE 5409: Updated Mapping for TP/MCH/BV-12-C, TP/MCH/BV-13-C, TP/MCH/BV-25-C, and TP/MCH/BV-26-C.

Publication Number	Revision Number	Date	Comments
			TSE 5519: Updated Test Case Description and added 5.5 as a reference for TP/FOC/BV-04-C. SEE update to TSE 5519 in revision 4.1.1r04
	4.1.1r02	2014-04-21	TSE 5580: Updated MSC for TP/LE/CFC/BV-01-C, TP/LE/CFC/BV-03-C; Updated MSC, Test Procedure and Pass verdict for TP/LE/CFC/BV-02-C; Numbered the Test Procedure for TP/LE/CFC/BV-06-C; Updated Test Procedure for TP/LE/CFC/BV-07-C and TP/LE/CFC/BV-12-C; Updated Initial Condition of TP/LE/CFC/BV-10-C and TP/LE/CFC/BV-14-C; Updated Initial Condition and Test Procedure of TP/LE/CFC/BV-11-C.
	4.1.1r04	2014-06-21	Update to TSE 5519: Removed TP/FOC/BV-04-C.
21	4.1.1	2014-07-07	TCRL 2014-1 Publication
	4.1.2r00	2014-10-21	TSE 5787: Added TC descriptions to TP/LE/CID/BV-01-C and TP/LE/CID/BV-02-I. TSE 5920: Corrected MSC for TP/COS/CED/BI-01-C. TSE 5810: Updated CID numbers in TP/LE/CID/BV-01-C and TP/LE/CID/BV-02-I. Updated TP/CID/BV-02-I to a conformance test, TP/CID/BV-02-C. Updated TCMT for the –I to –C change. Updated PIXIT to IXIT, and MMI to Upper Tester.
	4.2.0r00	2014-11-17	Revved version to align with Core Specification Version 4.2 Release.
	4.2.0r01	2014-11-25	BTI Review, Alicia, minor editorial corrections.
22	4.2.0	2014-12-04	Prepare for TCRL 2014-2 publication
	4.2.1r00	2015-05-05	TSE 6093: Updated TCMT to correct mapping for TP/COS/CED/BV-04-C & TP/LE/CFC/BV-08-C (items L2CAP 2/45 & 2/46) TSE 6335: Updated TP/ERM/BV-07-C to enable testing of both scenarios in PTS (via IXIT). TSE 5520: Deleted test TP/ERM/BV-21-C and removed it from TCMT.
	4.2.1r01	2015-06-03	Updated date conventions and formatting in revision history table.
	4.2.1r02	2015-06-15	TSE 6434: Added feature descriptions to TCMT for TP/LE/CID/BV-01-C and TP/LE/CID/BV-02-C.
23	4.2.1	2015-07-14	Prepared for TCRL 2015-1 publication
	4.2.2r00	2015-10-07	TSE 6400: Added clarifying text to TP/FIX/BV-02-C initial conditions and corrected InfoType in MSC for TP/FIX/BV-02-C.
	4.2.2r01	2015-10-23	Reviewed by Alicia Courtney. Updated terminology in 3.1 from “Host Subsystem” to “Host”.
24	4.2.2	2015-12-22	Prepared for TCRL 2015-2 publication.

Publication Number	Revision Number	Date	Comments
	4.2.3r00	2016-02-16	TSE 6812: MSCs updated for test cases TP/COS/CFC/BV-01-C, TP/COS/CFC/BV-02-C, TP/COS/CFC/BV-03-C, TP/COS/CFC/BV-04-C, TP/COS/CFC/BV-05-C, TP/LE/CFC/BV-03-C. "LE Data Channel established"/"Channel Established" changed to "LE Credit Based Flow Control Channel established".
	4.2.3r01	2016-02-22	TSE 6725: Typo in I-frame at last sequence corrected: "N(R)=0" changed to "N(R)=0 or 1"
	4.2.3r02	2016-03-02	TSE 6680: Added new four new test procedures (Sections 4.4.3.19–22) and test cases to TCMT: TP/LE/CFC/BV-18-C – 21-C.
	4.2.3r03	2016-04-28	Reviewed by BTI, Alicia. Editorial corrections. Some MSCs updated.
25	4.2.3	2015-07-13	Prepared for TCRL 2016-1 publication.
	5.0.0r00	2016-08-17	TSE 7266: Updated Initial Condition and Test Procedure for test case TP/LE/CID/BV-01-C and TP/LE/CID/BV-02-C.
	5.0.0r01	2016-11-20	Five test cases added back into TCMT which were erroneously deleted after integration of TSE 5406: TP/MCH/BV-01-C, TP/MCH/BV-04-C, TP/MCH/BV-06-C, TP/MCH/BV-08-C, TP/MCH/BV-10-C
26	5.0.0	2016-12-13	Approved by BTI. Prepared for TCRL 2016-2 publication.
	5.0.1r00	2017-03-27	TSE 7691: Reworded the pass verdict for L2CAP/COS/CFC/BV-01-C. TSE 8527: Updated TCMT item to "L2CAP 2/45" for L2CAP/COS/CED/BV-04-C. Updated TCMT item to "L2CAP 2/46 AND L2CAP 2/45a" for L2CAP/LE/CFC/BV-08-C.
	5.0.1r01	2017-05-22	Converted to new Test Case ID conventions as defined in TSTO v4.1.
27	5.0.1	2017-07-05	Approved by BTI. Prepared for TCRL 2017-1 publication.
	5.0.2r00	2017-08-17	TSE 9506: Revised TCMT for L2CAP/COS/CFD/BV-08-C to "L2CAP 1/1 AND L2CAP 2/2".
	5.0.2r01	2017-09-05	TSE 9751: Revised text in the Channel Identifiers (CID) test group objective and revised test procedure steps for L2CAP/LE/CID/BV-01-C and L2CAP/LE/CID/BV-02-C.
28	5.0.2	2017-12-07	Approved by BTI. Prepared for TCRL 2017-2 publication.
	5.1.0r00	2018-11-13	Updated revision number to 5.1.0 to align with the adoption of Core Specification version 5.1.
29	5.1.0	2018-12-07	Approved by BTI. Prepared for TCRL 2018-2 publication.

Publication Number	Revision Number	Date	Comments
	5.1.1r00–r02	2019-04-15– 2019-06-13	<p>TSE 11717 (rating 1): Updated text in the first paragraph of the Test Strategy in the Test Suite Structure (TSS) to address an issue with redundant PDUs.</p> <p>Editorial: rephrased “<i>The Lower Tester utilizes version 1.2 Basic Mode</i>” to “<i>The Lower Tester utilizes version L2CAP Basic Mode</i>” throughout and moved statement from test purpose to initial condition in those instances where it existed.</p>
30	5.1.1	2019-08-01	Approved by BTI. Prepared for TCRL 2019-1 publication.
	p31r00–r08	2019-08-21 – 2019-11-22	<p>Added test groups to accommodate adoption of Core Specification v5.2 with regard to EATT CR r07. Updated References with new Core Specification. Updated Test Groups with new terminology. Updated TCID Conventions table with new abbreviation. Updated Connection Oriented Basic L2CAP Mode with new test cases L2CAP/COS/ECFC/BV-01-C – -03-C; deleted for test cases L2CAP/LE/CFB/BV-08-C – -10-C, -12-C, -13-C, -15-C, and -17-C (TCIDs added to tables under news); added Connection Oriented Enhanced L2CAP Mode, including addition of test cases L2CAP/ECFC/BV-01-C – -04-C, -06-C – -27-C and BI-01-C – -04-C; added new test cases L2CAP/LE/CID/BV-03-C and -04-C to Channel Identifiers (CID). Updated TCMT accordingly.</p> <p>Issue 12289 (CR r03 file from comment 48454). Replaced MSCs for test cases L2CAP/COS/ECFC/BV-03-C, L2CAP/ECFC/BV-02-C – -04-C, L2CAP/ECFC/BV-10-C – -21-C; replaced MSCs and edited test step one for test cases L2CAP/ECFC/BV - 26-C and -27-C; edited initial condition for test cases L2CAP/LE/CID/BV-03-C and -04-C.</p> <p>Issue 12307 (CR from comment 48456). Updated MSC and test Step 4 for test case L2CAP/ECFC/BV-22-C; updated MSC and test Step 3 for test case L2CAP/ECFC/BV-23-C; updated MSC, added new test Step 2, and updated the pass verdict for test case L2CAP/ECFC/BI-03-C; updated MSC and test Steps 3 and 6 for test case L2CAP/ECFC/BV-24-C; updated MSC and test Steps 4 and 7 for test case L2CAP/ECFC/BV-25-C; updated MSC and updated test steps and pass verdict for test case L2CAP/ECFC/BI-04-C.</p>

Publication Number	Revision Number	Date	Comments
			<p>Issue 12411 (CR from comment 49159). Updated test purpose, replaced MSC, updated test Step 2 (additional text to Issue 12307) and deleted test Step 4 (was Step 3 before Issue 12307), and modified Pass Verdict (same text as Issue 12307 for that paragraph) for test case L2CAP/ECFC/BI-03-C; updated test purpose, replaced MSC, added text to test Step 2 (additional text to Issue 12307) and deleted Step 4 (was Step 3 before Issue 12307), and modified Pass Verdict (same text as Issue 12307 for that paragraph) for test case L2CAP/ECFC/BI-04-C.</p> <p>Issue 12484 (CR from comment 49740). Added “Notes” heading to Test Cases tables and replaced text in PSM column for the first item in those tables for the “Connection Oriented Enhanced L2CAP Modes’s subsections as follows: “Disconnection Request”, “Disconnection Response”, “Security – Insufficient Authentication – Initiator”, “Security – Insufficient Authorization – Initiator”, “Security - Insufficient Authorization – Responder”, “Security – Insufficient Encryption Key Size – Responder”, and “L2CAP Credit Based Connection Request – refused due to insufficient resources”; didn’t make change for “L2CAP Credit Based Connection Request – refused due to Invalid Source CID” because those test cases are still in two separates.</p> <p>TSE 12429 (rating 1): Already incorporated into LL.TS.Milan_r00 as part of the EATT CR integration. Affected test cases L2CAP/LE/CFC/BV-08-C – -10-C, -12-C, -13-C, -15-C, and -16-C.</p> <p>Issue 12522 (CR from comment 50029): Added test case L2CAP/ECFC/BI-05-C; updated TCMT entry per email from Cloud2Gnd (Virgil Dragomir, 2019-09-25).</p> <p>Issue 12626 (CR from comment 51183): Updated TCMT to clear references to TBDs.</p> <p>Issue 12630 (CR from comment 51702): Updated Reference, Initial Condition, MSC, and test steps, and added an Inconclusive Verdict for test cases L2CAP/ECFC/BV-24-C and -25-C (for -25-C, also updated Pass Verdict).</p> <p>Issue 12729 (CR from comment 51741): Added new test case L2CAP/ECFC/BI-06-C and updated TCMT accordingly.</p> <p>TSE 11162 (rating 3): For test case L2CAP/COS/CFD/BV-12-C, updated test purpose, test procedure (added rounds table), MSC, and pass verdict. Added new test case L2CAP/COS/CFD/BV-14-C and updated the TCMT accordingly.</p> <p>Replaced .X and Milan references to real numbers. Revised document numbering convention, setting last release publication of 5.1.1 as p30; added publication number column to Revision History.</p>
31	p31	2020-01-07	Approved by BTI on 2019-12-22. Prepared for TCRL 2019-2 publication.

Publication Number	Revision Number	Date	Comments
	p32r00-r28	2020-01-24 – 2021-06-09	<p>TSE 12837 (rating 4): To address E12684 regarding adding an L2CAP test on potential deadlock on collision, added a reference to the GAP spec, added “TIM” to the TCID identifier table (and editorially cleaned up table), and added new TCs L2CAP/TIM/BV-01-C – -03-C. Updated TCMT accordingly.</p> <p>TSE 12929 (rating 2): Updated TCMT to account for new Security Aspects table in ICS document.</p> <p>TSE 12937 (rating 1): Updated “LE_PSM” to “SPSM” to align with an erratum that was filed for EATT, affecting test cases L2CAP/COS/CFC/BV-01-C – -05-C; L2CAP/LE/CFC/BV-01-C – -07-C, -11-C, -14-C, and -17-C – 21-C; L2CAP/LE/CFC/BI-01-C; and L2CAP/LE/CID/BV-01-C and -02-C.</p> <p>TSE 13027 (rating 2): Updated test procedure and replaced MSC for test cases L2CAP/ECFC/BV-22-C and -23-C to improve test time.</p> <p>TSE 13214 (rating 2): Updated initial condition, MSC, and test step for test case L2CAP/ECFC/BI-04-C, and updated test purpose, initial condition, MSC, and test step for test case L2CAP/ECFC/BI-05-C.</p> <p>TSE 13220 (rating 4): Added new tests to accommodate additional L2CAP ECBFC Conformance Tests. New test cases: L2CAP/ECFC/BV-28-C – -35-C and L2CAP/LE/CFC/BV-22-C – -28-C. Updated TCMT accordingly.</p> <p>TSE 13405 (rating 1): Fixed typo in TCMT.</p> <p>TSE 13577 (rating 1): Removed inconclusive verdict for test case L2CAP/ECFC/BI-03-C to better align with spec.</p> <p>TSE 14659 (rating 1): Updated MSCs (and in some cases pass verdicts) for test cases L2CAP/COS/CED/BV-01-C and -05-C; L2CAP/COS/CFD/BV-08-C; L2CAP/CMC/BV-01-C, -03-C, -04-C, and -06-C – -15-C; L2CAP/CMC/BI-01-C – -06-C; L2CAP/FOC/BV-01-C – -03-C; L2CAP/EWC/BV-01-C – -03-C; L2CAP/LE/CPU/BV-01-C and -02-C; and L2CAP/LE/CPU/BI-01-C and -02-C to accommodate a PDU name change per Erratum 13186.</p> <p>TSE 14672 (rating 4): To address an issue with missing L2CAP tests for fragmentation and reassembly, added new TCs L2CAP/COS/CED/BV-12-C and -13-C and /BI-02-C; L2CAP/ECFC/BV-39-C – -42-C and /BI-08-C and -09-C; and L2CAP/LE/CFC/BV-30-C and -31-C and /BI-02-C. Updated TCMT accordingly.</p> <p>TSE 14675 (rating 2): Updated initial condition and test steps for test case L2CAP/ECFC/BV-24-C to correct language about the SDU size.</p>

Publication Number	Revision Number	Date	Comments
			<p>TSE 14697 (ratings 1 and 3): Moved “LE Credit Based Flow Control Mode” section from a subsection of 4.10 to a subsection of 4.13, moved all multiple mode tests (table-based test case config) to a new “All Credit Based Flow Control Mode” section (including those added for TSE 13220), and made other edits to existing tests as per red text in CR under “[New Section]” categorization. Category 1 change for test cases L2CAP/ECFC/BV-10-C, -12-C, -13-C, -15-C, -16-C. Category 3 change for test cases L2CAP/LE/CFC/BV-10-C, -12-C, -13-C, -15-C, -16-C.</p> <p>TSE 14759 (rating 2): For test case L2CAP/ECFC/BV-17-C, replaced MSC, updated test steps, updated pass verdict, and deleted inconclusive verdict. For test case L2CAP/ECFC/BV-21-C, deleted an initial condition, updated test steps, and deleted inconclusive verdict. For test case L2CAP/ECFC/BI-03-C, deleted an initial condition, updated test steps. For test case L2CAP/ECFC/BV-24-C, updated initial condition, replaced MSC, updated test steps, updated pass verdict, and deleted inconclusive verdict. For test case L2CAP/ECFC/BV-25-C, deleted inconclusive verdict. For test case L2CAP/ECFC/BV-27-C, replaced MSC, updated test steps, updated pass verdict, and deleted inconclusive verdict.</p> <p>TSE 14994 (rating 2): For section containing test cases L2CAP/LE/CFC/BV-15-C and L2CAP/ECFC/BV-15-C, updated initial condition, replaced MSC, updated test steps, updated pass verdict. Updated L2CAP/ECFC/BV-15-C to Category D in the TCRL (L2CAP/LE/CFC/BV-15-C was already Category D).</p> <p>TSE 15077 (rating 3): For test case L2CAP/COS/CED/BV-08-C, replaced MSC, updated test procedure, updated pass verdict.</p> <p>TSE 15410 (rating 2): To address an issue with the incorrect MTU value being sent, updated initial condition, MSC, test steps, and pass verdict for TC L2CAP/ECFC/BV-27-C (NOTE: overwrites changes made under TSE 14759 for this TC only). Updated reference [3] from “no longer used” to refer to the Core.IXIT.</p> <p>TSE 15450 (rating 1): Editorials to address Erratum 15353, globally change “Master” to “Central” and “Slave” to “Peripheral.”</p> <p>TSE 15612 (rating 4): To address E15554, L2CAP Credit Based Reconfigure Request - MPS greater or equal to all destination CIDs, added new TC L2CAP/ECFC/BI-07-C and updated TC L2CAP/ECFC/BI-04-C. Updated TCMT accordingly.</p>



Publication Number	Revision Number	Date	Comments
			<p>TSE 15868 (rating 4): To address E15833, ignore PDUs on a CID that is not assigned or RFU, updated the Channel Identifiers test group objectives and added new TCs L2CAP/COS/CID/BI-01-C, L2CAP/LE/CID/BI-01-C, and L2CAP/CLS/CID/BV-01-C. Updated TCMT accordingly.</p> <p>TSE 15918 (rating 4): To address E15323, regarding "Source, Destination CID dynamically changed", added new section "Credit Based Connection Request Dynamically Allocated Source CID" which includes new TCs L2CAP/ECFC/BV-38-C and L2CAP/LE/CFC/BV-29-C. Updated TCMT accordingly.</p> <p>TSE 16021 (rating 1): To address parameter name changes from E15944, updated MSCs for TCs L2CAP/LE/CPU/BV-01-C and -02-C and L2CAP/LE/CPU/BI-01-C and -02-C.</p> <p>TSE 16088 (rating 1): Corrected Opcode in test step for TC L2CAP/ECFC/BI-03-C.</p> <p>TSE 16149 (rating 3): To address an issue with needing to encrypt a link before sending an LE_Credit_Based_Connection_Request, updated references to include line items for the SM.TS and the LMP.TS; added a Setup Preambles/Encryption Key Size section; and updated TC L2CAP/LE/CFC/BV-11-C, the section containing TCs L2CAP/LE/CFC/BV-13-C and L2CAP/ECFC/BV-13-C, and the section containing TCs L2CAP/LE/CFC/BV-15-C and L2CAP/ECFC/BV-15-C.</p> <p>TSE 16953 (rating 2): Updated Step 17 of TC L2CAP/CLS/CID/BV-01-C.</p> <p>TSE 16955 (rating 2): Updated Step 3 of section containing TCs L2CAP/LE/CFC/BI-02-C and L2CAP/ECFC/BI-08-C.</p> <p>TSE 16964 (rating 1): Updated MSC and test step for section containing TCs L2CAP/LE/CFC/BV-25-C and L2CAP/ECFC/BV-32-C.</p> <p>Template-related editorials.</p>
32	p32	2021-07-13	Approved by BTI on 2021-06-27. Prepared for TCRL 2021-1 publication.
	p33r00-r07	2021-08-17 – 2021-12-16	<p>TSE 15271 (rating 4): To address E14605, added new TCs L2CAP/ECFC/BV-43-C and -44-C; updated TCMT accordingly. Updated TCMT item entries for TCs L2CAP/ECFC/BV-10-C – -15-C.</p> <p>TSE 15582 (rating 2): To address an issue with initial conditions and/or test procedures not being consistent for all IUTs, updated initial conditions, test procedures, MSCs, and Pass verdicts for L2CAP/ECFC/BV-22-C – -25-C.</p> <p>TSE 16083 (rating 4): Added new TC L2CAP/COS/ECFC/BV-04-C; updated TCMT accordingly.</p>

Publication Number	Revision Number	Date	Comments
			<p>TSE 16780 (rating 2): To avoid forcing EATT PSM, updated the initial condition (and in many cases the MSC, test steps, and/or TC Config table) for the following TCs: L2CAP/COS/ECFC/BV-01-C – -03-C; L2CAP/ECFC/BV-01-C – -04-C and -06-C – -35-C, and -38-C – -44-C; L2CAP/ECFC/BI-01-C – -08-C; L2CAP/LE/CFC/BV-08-C – -10-C and -12-C, -13-C, -15-C, -16-C, and -22-C – -31-C; L2CAP/LE/CFC/BI-02-C; and L2CAP/LE/CID/BV-03-C and -04-C.</p> <p>TSE 16954 (rating 3): Updated CID column, MSC, test steps, and Pass verdict for section containing TCs L2CAP/ECFC/BV-38-C and L2CAP/LE/CFC/BV-29-C.</p> <p>TSE 16995 (rating 3): Corrected the initial condition, MSC, test steps, and Pass verdict for TC L2CAP/LE/CID/BI-01-C.</p> <p>TSE 17086 (rating 2): Replaced the MSC for TC L2CAP/ECFC/BV-29-C and updated the code number in Step 2 for the section containing TCs L2CAP/LE/CFC/BV-23-C and L2CAP/ECFC/BV-30-C.</p> <p>TSE 17340 (rating 2): Replaced MSCs for TCs L2CAP/COS/CED/BV-12-C and -13-C and for sections containing TCs L2CAP/LE/CFC/BV-30-C, L2CAP/ECFC/BV-39-C, and -40-C and L2CAP/LE/CFC/BV-31-C and L2CAP/ECFC/BV-41-C and -42-C.</p> <p>TSE 17401 (rating 2): Updated TCMT entry for L2CAP/LE/CID/BI-01-C. Updated TCMT intro text to align with latest template.</p> <p>TSE 17463 (rating 4): Split ECFC tests by transport where they are not currently specified as supported by a single transport. Corrected the TCMT for the new and updated ICS items for Enhanced Credit Based Flow Control Mode – BR/EDR and LE transports. Affected test cases: L2CAP/COS/ECFC/BV-01-C – -04-C; L2CAP/ECFC/BV-01-C – -04-C, -06-C – -35-C, -43-C, and -44-C; L2CAP/ECFC/BI-01-C – -07-C. New test cases: L2CAP/COS/ECFC/BV-05-C – -08-C; L2CAP/ECFC/BV-45-C – -79-C; and L2CAP/ECFC/BI-10-C – -16-C. Updated TCMT accordingly.</p> <p>TSE 17581 (rating 2): Updated the MSC, test steps, and pass verdict for the section containing L2CAP/ECFC/BV-38-C and L2CAP/LE/CFC/BV-29-C.</p> <p>TSE 17905 (rating 1): Combined TCMT entries for L2CAP/COS/CED/BV-03-C and -13-C.</p> <p>Performed template-related formatting fixes. Updated the introduction text before the TCMT to align with the template and the copyright page to align with v2 of the DNMD.</p>
33	p33	2022-01-25	Approved by BTI on 2021-12-27. Prepared for TCRL 2021-2 publication.

Publication Number	Revision Number	Date	Comments
	p33ed2r00-r01	2022-02-15 – 2022-03-07	<p>TSE 18240 (rating 1): Changed “LE-frame” and “LE frame” to “K-frame” globally, including in descriptions for TCs L2CAP/LE/CFC/BV-26-C – -28-C, L2CAP/ECFC/BV-33-C – -35-C, and -76C – -78-C.</p> <p>TSE 18241 (rating 1): Changed “Kframe” and “K-Frame” to “K-frame” globally.</p> <p>Performed template-related formatting fixes. Updated the introduction text before the TCMT to align with the revised template.</p>
	p33 edition 2	2022-03-07	Approved by BTI on 2022-03-07. Prepared for edition 2 publication.
	p34r00-r04	2022-03-07 – 2022-05-04	<p>TSE 17725 (rating 2): Updated the MSC, test procedure, and expected outcome for L2CAP/CLS/CID/BV-01-C.</p> <p>TSE 17728 (rating 3): Deleted test case L2CAP/COS/CID/BI-01-C as a standalone test; combined it with L2CAP/LE/CID/BI-01-C to create a table-driven test. Updated the test header, test purpose, initial condition, MSC, test procedure, and expected outcome and added a test case configuration table for TCs L2CAP/COS/CID/BI-01-C and L2CAP/LE/CID/BI-01-C. Updated TCMT items for L2CAP/COS/CID/BI-01-C and L2CAP/LE/CID/BI-01-C.</p> <p>TSE 18192 (rating 2): Updated test procedures (and in some cases MSCs or test purposes) for test cases L2CAP/COS/CED/BV-12-C and -13-C, L2CAP/COS/CED/BI-02-C, L2CAP/COS/CFC/BV-01-C and -03-C, L2CAP/LE/CFC/BV-31-C, L2CAP/ECFC/BV-41-C and -42-C, L2CAP/LE/CFC/BI-02-C, L2CAP/ECFC/BI-08-C and -09-C, L2CAP/ERM/BI-01-C, and L2CAP/COS/ECFC/BV-01-C, -02-C, -05-C, and -06-C to eliminate ambiguities per Erratum 16187.</p> <p>TSE 18242 (rating 2): Added a test case configuration table and updated the test procedure for L2CAP/LE/CFC/BV-30-C, L2CAP/ECFC/BV-39-C, and -40-C. Added a TCC table and updated the initial condition and MSC for L2CAP/LE/CFC/BV-31-C, L2CAP/ECFC/BV-41-C, and -42-C. Added a TCC table and updated the test procedure for L2CAP/LE/CFC/BI-02-C and L2CAP/ECFC/BI-08-C. Added a new TCC table and updated the existing TCC table, initial condition, and MSC for L2CAP/LE/CFC/BV-08-C, L2CAP/ECFC/BV-08-C, and -65-C. Added a new TCC table and updated the initial condition for L2CAP/LE/CFC/BV-09-C, L2CAP/ECFC/BV-09-C, and -66-C. Added a TCC table and updated the test procedure for L2CAP/LE/CFC/BV-22-C, L2CAP/ECFC/BV-28-C, and -72-C. Added a new TCC table and updated the initial condition for L2CAP/LE/CFC/BV-23-C, L2CAP/ECFC/BV-30-C, and -73-C. Added a new TCC table and updated the test procedure for L2CAP/LE/CFC/BV-24-C, L2CAP/ECFC/BV-31-C, and</p>



Publication Number	Revision Number	Date	Comments
			<p>-74-C. Added a new TCC table and updated the test procedure for L2CAP/LE/CFC/BV-25-C, L2CAP/ECFC/BV-32-C, and -75-C. Added a new TCC table and updated the initial condition and MSC for L2CAP/LE/CFC/BV-26-C, L2CAP/ECFC/BV-33-C, and -76-C. Added a new TCC table and updated the initial condition and MSC for L2CAP/LE/CFC/BV-27-C, L2CAP/ECFC/BV-34-C, and -77-C. Added a new TCC table for L2CAP/LE/CFC/BV-28-C, L2CAP/ECFC/BV-35-C, and -78-C.</p> <p>TSE 18295 (rating 2): Updated the initial condition and test procedure and deleted the test conditions for L2CAP/LE/CPU/BV-01-C.</p> <p>TSE 18297 (rating 2): Updated the TCMT item for L2CAP/ECFC/BV-68-C to replace L2CAP 1/5 AND L2CAP 2/48b AND L2CAP 4/2 with L2CAP 1/1 AND L2CAP 2/48a AND L2CAP 5/2.</p> <p>TSE 18301 (rating 2): Updated the TCMT item for L2CAP/LE/CID/BV-04-C to replace L2CAP 2/48 with L2CAP 2/48a AND L2CAP 2/48b.</p> <p>TSE 18384 (rating 2): Added new Sections 4.9, Common Packet Contents, and 4.91, Fields and Bits Reserved for Future Use.</p> <p>TSE 18441 (rating 2): Modified initial condition of L2CAP/COS/CFD/BV-11-C, adding a new IXIT value.</p> <p>TSE 18544 (rating 1): Removed L2CAP/ECFC/BV-74-C and -75-C; updated the TCMT and TCRL accordingly.</p> <p>Performed template-related formatting fixes. Made consistency checker editorials.</p>
34	p34	2022-06-28	Approved by BTI on 2022-05-31. Prepared for TCRL 2022-1 publication.
	p34ed2 r00-r01	2022-07-19 – 2022-08-17	<p>TSE 18915 (rating 1): Standardized the various ways ACL connections are described in the Initial Conditions section for the following test cases: L2CAP/COS/CED/BI-02-C; L2CAP/COS/CFC/BV-01-C – -05-C; L2CAP/LE/CFC/BV-01-C – -31-C; L2CAP/ECFC/BV-01-C – -04-C, -06-C – -35-C, -38-C, -39-C, -42-C, -45-C – -73-C, -76-C – -79-C; L2CAP/LE/CFC/BI-01-C and -02-C; L2CAP/ECFC/BI-01-C – -16-C; L2CAP/COS/ECFC/BV-01-C – -08-C; and L2CAP/LE/REJ/BI-02-C.</p> <p>Template-related editorials.</p>
	p34 edition 2	2022-08-23	Approved by BTI on 2022-08-22. Prepared for edition 2 publication.
	p35r00	2022-08-24	<p>TSE 18813 (rating 2): Deleted a test step for the section containing L2CAP/ECFC/BI-03-C and -12-C.</p> <p>TSE 18837 (rating 2): Updated the TCMT entries for L2CAP/TIM/BV-02-C and -03-C.</p>
35	p35	2023-02-07	Approved by BTI on 2022-12-28. Prepared for TCRL 2022-2 publication.

Publication Number	Revision Number	Date	Comments
	p36r00	2023-04-03	<p>TSE 19049 (rating 3): Updated the Test Purpose, Initial Condition, MSC, test steps, and Pass verdict for the section containing L2CAP/ECFC/BV-29-C and -64-C.</p> <p>TSE 22286 (rating 2): Updated a Reference and added an Initial Condition for the section containing L2CAP/TIM/BV-01-C – -03-C.</p>
36	p36	2023-06-29	Approved by BTI on 2023-06-05. Prepared for TCRL 2023-1 publication.
	p37r00–r06	2023-10-05 – 2024-05-12	<p>TSE 17840 (rating 2): Corrected the TCMT entries for L2CAP/TIM/BV-01-C – -03-C.</p> <p>TSE 18351 (rating 3): Deleted L2CAP/ECFC/BV-44-C and -51-C, revised L2CAP/ECFC/BV-69-C to also cover what was previously covered under -44-C, revised L2CAP/ECFC/BV-11-C to a standalone test, revised the section containing L2CAP/LE/CFC/BV-13-C and L2CAP/ECFC/BV-13-C, and revised L2CAPECFC/BV-43-C. Updated the TCMT accordingly.</p> <p>TSE 22166 (rating 4): Deleted L2CAP/EXF/BV-01-C – -06-C. Added new test L2CAP/EXP/BV-01-C. Updated the TCMT accordingly.</p> <p>TSE 23052 (rating 4): Per E23048, to address how the absence of the FCS Option bit is handled, combined L2CAP/FOC/BV-01-C – -03-C into one table-based test section, updating the test purpose, initial condition, MSC, and Pass verdict to align, and added new tests L2CAP/FOC/BV-04-C and BV-05-C. Updated the TCMT accordingly.</p> <p>TSE 24849 (rating 2): Updated the description of L2CAP/ECFC/BI-09-C to include BR/EDR and updated the TCMT entry for L2CAP/LE/REJ/BI-01-C.</p> <p>TSE 24929 (rating 2): Updated the MSCs for L2CAP/ERM/BV-17-C and /BI-02-C.</p> <p>TSE 24933 (rating 3): Combined L2CAP/COS/CED/BI-01 and L2CAP/LE/REJ/BI-02-C into one section with a test case configuration table. Updated the TCMT accordingly.</p>
37	p37	2024-07-01	Approved by BTI on 2024-05-22. Prepared for TCRL 2024-1 publication.
	p38r00	2024-07-19	<p>TSE 24934 (rating 1): Per E24985, deleted L2CAP/LE/REJ/BI-01-C and updated the TCMT accordingly.</p> <p>TSE 25417 (rating 1): Corrected the IXIT reference for L2CAP/COS/CED/BV-11-C in the initial condition, MSC, and Notes.</p> <p>TSE 25764 (rating 1): Corrected an ICS reference in the Test Case Configuration table for L2CAP/LE/REJ/BI-02-C.</p>
38	p38	2024-09-04	Approved by BTI on 2024-08-14. Prepared for TCRL 2024-2 publication.

Publication Number	Revision Number	Date	Comments
	p39r00-r07	2024-10-31 – 2024-12-14	<p>TSE 17703 (rating 4): Deleted TCs L2CAP/COS/CED/BV-05-C, -13-C, and BI-02-C and the entire section previously containing L2CAP/LE/CFC/BI-02-C and L2CAP/ECFC/BI-08-C. Added new TCs L2CAP/COS/CED/BI-03-C – 17-C. Updated the TC Configuration for L2CAP/COS/CED/BI-09-C. Added column to the TC Configuration table and updated the test procedure for L2CAP/COS/CED/BI-10-C and -11-C. Updated the TC description for L2CAP/COS/CED/BI-14-C. Updated the TCMT accordingly.</p> <p>TSE 25882 (rating 4): Updated the test case config table and the MSC for the section containing L2CAP/FOC/BV-01-C – -03-C. Converted L2CAP/FOC/BV-04-C from a standalone test into a table-based test and added new TC L2CAP/FOC/BV-06-C; updated MSC and rounds table. Converted L2CAP/FOC/BV-05-C from a standalone test into a table-based test and added new TCs L2CAP/FOC/BV-07-C and -08-C; updated MSC and rounds table. Updated the TCMT accordingly; also updated TCMT entries for L2CAP/OFS/BV-01-C – -08-C.</p> <p>TSE 25886 (rating 1): Editorial corrections to the rev history entries for TSEs 23052 and 24929.</p> <p>TSE 25902 (rating 2): Updated the test case config table, MSC, test steps, and Pass verdict for the section containing L2CAP/COS/CED/BI-01-C and L2CAP/LE/REJ/BI-02-C.</p> <p>TSE 25922 (rating 1): Updated generic IXIT references to use the TSPX naming for L2CAP/COS/CFD/BV-12-C and -14-C, L2CAP/COS/CFC/BV-01-C – -05-C, L2CAP/COS/ECFC/BV-01-C – -08-C, L2CAP/ECFC/BI-01-C – -07-C, L2CAP/ECFC/BI-09-C – -16-C, L2CAP/ECFC/BV-01-C – -04-C, L2CAP/ECFC/BV-06-C – -27-C, L2CAP/ECFC/BV-29-C – -35-C, L2CAP/ECFC/BV-38-C – -43-C, L2CAP/ECFC/BV-45-C – -50-C, L2CAP/ECFC/BV-52-C – -71-C, L2CAP/ECFC/BV-73-C, L2CAP/ECFC/BV-76-C – L2CAP/ECFC/BV-79-C, L2CAP/ERM/BV-07-C, L2CAP/LE/CFC/BI-01-C, L2CAP/LE/CFC/BV-01-C – -13-C, L2CAP/LE/CFC/BV-15-C – -17-C, L2CAP/LE/CFC/BV-20-C, L2CAP/LE/CFC/BV-23-C – -31-C, and L2CAP/LE/CID/BV-01-C – -04-C.</p> <p>TSE 26003 (rating 2): Updated the initial condition, MSC, and test steps for L2CAP/ECFC/BI-09-C.</p> <p>TSE 26416 (rating 2): Corrected the initial condition, test steps, MSC, and Pass verdict for the section containing L2CAP/ECFC/BI-02-C and -11-C.</p>
39	p39	2025-02-18	Approved by BTI on 2024-12-26. Prepared for TCRL 2025-1 publication.
	p40r00-r03	2025-02-03 – 2025-03-27	<p>TSE 17651 (rating 4): Added new TCs L2CAP/EXF/BV-08-C and L2CAP/FIX/BV-03-C to address a gap in feature masks testing. Updated the TCMT accordingly.</p>



Publication Number	Revision Number	Date	Comments
			<p>TSE 24756 (rating 4): Added new TCs L2CAP/LE/CFC/BV-32-C and L2CAP/ECFC/BV-80-C and -81-C to address the correct handling of a K-frame with SDU-length octets of data. Updated the TCMT accordingly.</p> <p>TSE 26629 (rating 2): Replaced the MSC for the section containing L2CAP/FOC/BV-05-C, -07-C, and -08-C.</p> <p>Per the BTI call on 2025-04-24, removed a broken cross-reference in L2CAP/COS/CED/BV-12-C by deleting unneeded introductory text in the test procedure “The testing procedure is executed similar to Reference source not found., with the exception that each transmission (C-frame) from the Lower Tester is fragmented into two fragments.” (the error text previously referred to the now-deleted L2CAP/COS/CED/BV-05-C).</p>
40	p40	2025-05-06	Approved by BTI on 2025-04-16. Prepared for TCRL 2025-2 publication.
	p41r00–r09	2025-07-16 – 2025-09-11	<p>TSE 26118 (rating 2): Deleted L2CAP/ECFC/BV-43-C and L2CAP/ECFC/BV-69-C. Updated the TCMT accordingly.</p> <p>TSE 26689 (rating 3): Corrected the Pass verdict for L2CAP/COS/CED/BV-08-C.</p> <p>TSE 27163 (rating 4): To support the changes needed for E26667, added new TCs L2CAP/COS/CED/BI-28-C and -29-C. Updated the TCMT accordingly.</p> <p>TSE 27216 (rating 2): Corrected an error code for L2CAP/LE/REJ/BI-02-C.</p> <p>TSE 27265 (rating 2): Updated the TCMT entries for L2CAP/COS/CED/BI-03-C, L2CAP/COS/CID/BI-01-C, and L2CAP/LE/CID/BI-01-C.</p> <p>TSE 27274 (rating 2): Corrected values in the test procedure for L2CAP/COS/CED/BI-06-C.</p> <p>TSE 27281 (rating 2): Added a column to the test case configuration table and updated the Test Procedure for L2CAP/COS/CED/BI-14-C – -15-C.</p> <p>TSE 27414 (rating 2): Corrected the Pass verdict for the section containing L2CAP/COS/CED/BI-10-C and -11-C.</p> <p>TSE 27460 (rating 2): Updated IXIT values throughout the TS. Replaced the Setup Preamble section with the Preamble IXITs table. Deleted Notes for L2CAP/COS/CED/BV-11-C. Updated the Initial Condition and Pass Verdict for L2CAP/COS/CFD/BV-11-C. Updated the Initial Condition and Test Procedure for the section containing L2CAP/COS/ECFC/BV-03-C and -07-C. Updated the Initial Condition for L2CAP/ECFC/BI-09-C, L2CAP/ERM/BV-23-C, L2CAP/STM/BV-03-C and -13-C, and L2CAP/ECF/BV-08-C.</p>

Publication Number	Revision Number	Date	Comments
			<p>TSE 27592 (rating 2): Updated the test purpose, MSC, test procedure, and Pass verdict for the section containing L2CAP/ECFC/BI-02-C and L2CAP/ECFC/BI-11-C.</p> <p>TSE 27636 (rating 4): Updated the section containing L2CAP/COS/CED/BI-04-C and -05-C, enhancing the description of -05-C, adding new tests L2CAP/COS/CED/BI-18-C and -19-C to the TCC, and making minor changes to the test procedure. Updated the section containing L2CAP/COS/CED/BI-08-C and -09-C, enhancing the description of -09-C, adding new tests L2CAP/COS/CED/BI-20-C and -21-C to the TCC, and making minor changes to the test procedure. Converted L2CAP/COS/CED/BI-13-C into a table-based test with new TCs L2CAP/COS/CED/BI-22-C and -23-C, enhancing the description of -13-C and making minor changes to the test procedure. Updated the section containing L2CAP/COS/CED/BI-16-C and -17-C, enhancing both test descriptions, expanding the scope of the TCC with new columns, adding new tests L2CAP/COS/CED/BI-24-C and -25-C to the TCC, and making minor changes to the test procedure and test purpose. Updated the TCMT accordingly.</p> <p>TSE 27644 (rating 3): Updated the test procedure and Pass verdict for L2CAP/COS/CED/BI-12-C.</p>
41	p41	2025-11-04	Approved by BTI on 2025-10-05. Prepared for TCRL pkg101 publication.
	p42r00–r05	2025-11-25 – 2026-02-17	<p>TSE 27729 (rating 4): Per E9480, added 2 new TCs: L2CAP/COS/CED/BI-30-C and L2CAP/COS/IEX/BI-01-C. Updated the TCMT and the references list.</p> <p>TSE 27960 (rating 2): Corrected a test step and Pass verdict for the section containing L2CAP/COS/CED/BI-14-C and -15-C.</p> <p>TSE 28027 (rating 1): Updated the TCMT to align with revisions made to Table 1 of the L2CAP ICS.</p> <p>TSE 28291 (rating 2): Replaced the MSC for the section containing L2CAP/FOC/BV-05-C, -07-C, and -08-C.</p> <p>TSE 28309 (rating 1): Corrected the TCID descriptions for L2CAP/COS/CED/BI-22-C and -23-C.</p> <p>TSE 28328 (rating 3): Updated the section heading, test purpose, TC description, and test procedure for L2CAP/LE/CFC/BV-23-C and L2CAP/ECFC/BV-30-C and -73-C.</p> <p>TSE 28495 (rating 2): Updated the MSC and test procedure for L2CAP/COS/CED/BI-28-C and -29-C.</p>
42	p42	2026-05-05	Approved by BTI on 2026-04-07. Prepared for TCRL pkg103 publication.

Acknowledgments

Name	Company
Virgil Dragomir	Bluetooth SIG, Inc.
Alicia Courtney	Broadcom
Leonid Eidelman	Broadcom
Ash Kapur	Broadcom
Angel Polo	Broadcom
Mayank Batra	CSR
Chris Church	CSR
Giriraj Goyal	CSR
Robin Heydon	CSR
Tim Howes	CSR
Neil Stewart	CSR
Harish Balasubramaniam	Intel
Magnus Eriksson	Intel
Oren Haggai	Intel
Marcel Holtmann	Intel
Robert Hughes	Intel
Yao Wang	IVT
Josselin De La Broise	Marvell
Anindya Bakshi	Mindtree
Shwetha Madadik	Mindtree
Krishna Singala	Mindtree
Niclas Granqvist	Polar
Joel Linsky	Qualcomm Atheros
Brian A. Redding	Qualcomm Atheros
Magnus Sommansson	Qualcomm Technologies International, Ltd.
Jean-Philippe Lambert	RivieraWaves
Masaya Masuda	Toshiba
Rasmus Abildgren	Samsung Electronics
Jason Hillyard	Wicentric

