

Gaming Audio Profile (GMAP)

Bluetooth® Test Suite

- **Revision:** GMAP.TS.p2
- **Revision Date:** 2025-11-04
- **Prepared By:** Audio, Telephony, and Automotive Working Group
- **Published during TCRL:** TCRL.pkg101



This document, regardless of its title or content, is not a Bluetooth Specification as defined in the Bluetooth Patent/Copyright License Agreement (“PCLA”) and Bluetooth Trademark License Agreement. Use of this document by members of Bluetooth SIG is governed by the membership and other related agreements between Bluetooth SIG Inc. (“Bluetooth SIG”) and its members, including the PCLA and other agreements posted on Bluetooth SIG’s website located at www.bluetooth.com.

THIS DOCUMENT IS PROVIDED “AS IS” AND BLUETOOTH SIG, ITS MEMBERS, AND THEIR AFFILIATES MAKE NO REPRESENTATIONS OR WARRANTIES AND DISCLAIM ALL WARRANTIES, EXPRESS OR IMPLIED, INCLUDING ANY WARRANTY OF MERCHANTABILITY, TITLE, NON-INFRINGEMENT, FITNESS FOR ANY PARTICULAR PURPOSE, THAT THE CONTENT OF THIS DOCUMENT IS FREE OF ERRORS.

TO THE EXTENT NOT PROHIBITED BY LAW, BLUETOOTH SIG, ITS MEMBERS, AND THEIR AFFILIATES DISCLAIM ALL LIABILITY ARISING OUT OF OR RELATING TO USE OF THIS DOCUMENT AND ANY INFORMATION CONTAINED IN THIS DOCUMENT, INCLUDING LOST REVENUE, PROFITS, DATA OR PROGRAMS, OR BUSINESS INTERRUPTION, OR FOR SPECIAL, INDIRECT, CONSEQUENTIAL, INCIDENTAL OR PUNITIVE DAMAGES, HOWEVER CAUSED AND REGARDLESS OF THE THEORY OF LIABILITY, AND EVEN IF BLUETOOTH SIG, ITS MEMBERS, OR THEIR AFFILIATES HAVE BEEN ADVISED OF THE POSSIBILITY OF SUCH DAMAGES.

This document is proprietary to Bluetooth SIG. This document may contain or cover subject matter that is intellectual property of Bluetooth SIG and its members. The furnishing of this document does not grant any license to any intellectual property of Bluetooth SIG or its members.

This document is subject to change without notice.

Copyright © 2022–2025 by Bluetooth SIG, Inc. The Bluetooth word mark and logos are owned by Bluetooth SIG, Inc. Other third-party brands and names are the property of their respective owners.



Contents

1	Scope	18
2	References, definitions, and abbreviations	19
2.1	References	19
2.2	Definitions	19
2.3	Acronyms and abbreviations	20
3	Test Suite Structure (TSS)	21
3.1	Overview	21
3.2	Test Strategy	23
3.2.1	Latency testing overview and procedures	24
3.2.2	Audio output synchronization overview and test configurations	34
3.2.3	Synchronization test methodologies	35
3.3	Test groups	35
4	Test cases (TC)	36
4.1	Introduction	36
4.1.1	Test case identification conventions	36
4.1.2	Conformance	37
4.1.3	Pass/Fail verdict conventions	37
4.2	Low Latency Audio Streaming – Unicast	38
4.2.1	Low Latency Audio Streaming – UGG	38
	GMAP/UGG/LLU/BV-63-C [Low Latency Streaming - AC1: 32_1_gr]	39
	GMAP/UGG/LLU/BV-64-C [Low Latency Streaming - AC1: 32_2_gr]	39
	GMAP/UGG/LLU/BV-51-C [Low Latency Streaming - AC1: 48_1_gr]	39
	GMAP/UGG/LLU/BV-52-C [Low Latency Streaming - AC1: 48_2_gr]	39
	GMAP/UGG/LLU/BV-53-C [Low Latency Streaming - AC1: 48_3_gr]	39
	GMAP/UGG/LLU/BV-54-C [Low Latency Streaming - AC1: 48_4_gr]	39
	GMAP/UGG/LLU/BV-87-C [Low Latency Streaming - AC2: 16_1_gs]	39
	GMAP/UGG/LLU/BV-88-C [Low Latency Streaming - AC2: 16_2_gs]	39
	GMAP/UGG/LLU/BV-55-C [Low Latency Streaming - AC2: 32_1_gs]	39
	GMAP/UGG/LLU/BV-56-C [Low Latency Streaming - AC2: 32_2_gs]	39
	GMAP/UGG/LLU/BV-57-C [Low Latency Streaming - AC2: 48_1_gs]	39
	GMAP/UGG/LLU/BV-58-C [Low Latency Streaming - AC2: 48_2_gs]	39
	GMAP/UGG/LLU/BV-69-C [Low Latency Streaming - AC4: 32_1_gr]	39
	GMAP/UGG/LLU/BV-70-C [Low Latency Streaming - AC4: 32_2_gr]	39
	GMAP/UGG/LLU/BV-59-C [Low Latency Streaming - AC4: 48_1_gr]	39
	GMAP/UGG/LLU/BV-60-C [Low Latency Streaming - AC4: 48_2_gr]	39
	GMAP/UGG/LLU/BV-61-C [Low Latency Streaming - AC4: 48_3_gr]	39
	GMAP/UGG/LLU/BV-62-C [Low Latency Streaming - AC4: 48_4_gr]	39
	GMAP/UGG/LLU/BV-73-C [Low Latency Streaming - AC6i: 32_1_gr]	39
	GMAP/UGG/LLU/BV-74-C [Low Latency Streaming - AC6i: 32_2_gr]	39
	GMAP/UGG/LLU/BV-01-C [Low Latency Streaming - AC6i: 48_1_gr]	39
	GMAP/UGG/LLU/BV-02-C [Low Latency Streaming - AC6i: 48_2_gr]	39
	GMAP/UGG/LLU/BV-03-C [Low Latency Streaming - AC6i: 48_3_gr]	40
	GMAP/UGG/LLU/BV-04-C [Low Latency Streaming - AC6i: 48_4_gr]	40
	GMAP/UGG/LLU/BV-75-C [Low Latency Streaming - AC6ii: 32_1_gr]	40
	GMAP/UGG/LLU/BV-76-C [Low Latency Streaming - AC6ii: 32_2_gr]	40
	GMAP/UGG/LLU/BV-05-C [Low Latency Streaming - AC6ii: 48_1_gr]	40
	GMAP/UGG/LLU/BV-06-C [Low Latency Streaming - AC6ii: 48_2_gr]	40
	GMAP/UGG/LLU/BV-07-C [Low Latency Streaming - AC6ii: 48_3_gr]	40
	GMAP/UGG/LLU/BV-08-C [Low Latency Streaming - AC6ii: 48_4_gr]	40



GMAP/UGG/LLU/BV-89-C [Low Latency Streaming - AC3: 32_1_gr, 16_1_gs].....	42
GMAP/UGG/LLU/BV-90-C [Low Latency Streaming - AC3: 32_2_gr, 16_2_gs].....	42
GMAP/UGG/LLU/BV-91-C [Low Latency Streaming - AC3: 48_1_gr, 16_1_gs].....	42
GMAP/UGG/LLU/BV-92-C [Low Latency Streaming - AC3: 48_2_gr, 16_2_gs].....	42
GMAP/UGG/LLU/BV-65-C [Low Latency Streaming - AC3: 32_1_gr, 32_1_gs].....	42
GMAP/UGG/LLU/BV-66-C [Low Latency Streaming - AC3: 32_2_gr, 32_2_gs].....	42
GMAP/UGG/LLU/BV-09-C [Low Latency Streaming - AC3: 48_1_gr, 32_1_gs].....	42
GMAP/UGG/LLU/BV-10-C [Low Latency Streaming - AC3: 48_2_gr, 32_2_gs].....	42
GMAP/UGG/LLU/BV-11-C [Low Latency Streaming - AC3: 48_1_gr, 48_1_gs].....	42
GMAP/UGG/LLU/BV-12-C [Low Latency Streaming - AC3: 48_2_gr, 48_2_gs].....	42
GMAP/UGG/LLU/BV-13-C [Low Latency Streaming - AC3: 48_3_gr, 32_1_gs].....	42
GMAP/UGG/LLU/BV-14-C [Low Latency Streaming - AC3: 48_4_gr, 32_2_gs].....	42
GMAP/UGG/LLU/BV-67-C [Low Latency Streaming - AC3: 48_3_gr, 48_1_gs].....	42
GMAP/UGG/LLU/BV-68-C [Low Latency Streaming - AC3: 48_4_gr, 48_2_gs].....	42
GMAP/UGG/LLU/BV-93-C [Low Latency Streaming - AC5: 32_1_gr, 16_1_gs].....	43
GMAP/UGG/LLU/BV-94-C [Low Latency Streaming - AC5: 32_2_gr, 16_2_gs].....	43
GMAP/UGG/LLU/BV-95-C [Low Latency Streaming - AC5: 48_1_gr, 16_1_gs].....	43
GMAP/UGG/LLU/BV-96-C [Low Latency Streaming - AC5: 48_2_gr, 16_2_gs].....	43
GMAP/UGG/LLU/BV-71-C [Low Latency Streaming - AC5: 32_1_gr, 32_1_gs].....	43
GMAP/UGG/LLU/BV-72-C [Low Latency Streaming - AC5: 32_2_gr, 32_2_gs].....	43
GMAP/UGG/LLU/BV-15-C [Low Latency Streaming - AC5: 48_1_gr, 32_1_gs].....	43
GMAP/UGG/LLU/BV-16-C [Low Latency Streaming - AC5: 48_2_gr, 32_2_gs].....	43
GMAP/UGG/LLU/BV-17-C [Low Latency Streaming - AC5: 48_1_gr, 48_1_gs].....	43
GMAP/UGG/LLU/BV-18-C [Low Latency Streaming - AC5: 48_2_gr, 48_2_gs].....	43
GMAP/UGG/LLU/BV-19-C [Low Latency Streaming - AC5: 48_3_gr, 32_1_gs].....	43
GMAP/UGG/LLU/BV-20-C [Low Latency Streaming - AC5: 48_4_gr, 32_2_gs].....	43
GMAP/UGG/LLU/BV-97-C [Low Latency Streaming - AC7ii: 32_1_gr, 16_1_gs].....	43
GMAP/UGG/LLU/BV-98-C [Low Latency Streaming - AC7ii: 32_2_gr, 16_2_gs].....	43
GMAP/UGG/LLU/BV-99-C [Low Latency Streaming - AC7ii: 48_1_gr, 16_1_gs].....	43
GMAP/UGG/LLU/BV-100-C [Low Latency Streaming - AC7ii: 48_2_gr, 16_2_gs].....	44
GMAP/UGG/LLU/BV-41-C [Low Latency Streaming - AC7ii: 32_1_gr, 32_1_gs].....	44
GMAP/UGG/LLU/BV-42-C [Low Latency Streaming - AC7ii: 32_2_gr, 32_2_gs].....	44
GMAP/UGG/LLU/BV-21-C [Low Latency Streaming - AC7ii: 48_1_gr, 32_1_gs].....	44
GMAP/UGG/LLU/BV-22-C [Low Latency Streaming - AC7ii: 48_2_gr, 32_2_gs].....	44
GMAP/UGG/LLU/BV-23-C [Low Latency Streaming - AC7ii: 48_1_gr, 48_1_gs].....	44
GMAP/UGG/LLU/BV-24-C [Low Latency Streaming - AC7ii: 48_2_gr, 48_2_gs].....	44
GMAP/UGG/LLU/BV-25-C [Low Latency Streaming - AC7ii: 48_3_gr, 32_1_gs].....	44
GMAP/UGG/LLU/BV-26-C [Low Latency Streaming - AC7ii: 48_4_gr, 32_2_gs].....	44
GMAP/UGG/LLU/BV-77-C [Low Latency Streaming - AC7ii: 48_3_gr, 48_1_gs].....	44
GMAP/UGG/LLU/BV-78-C [Low Latency Streaming - AC7ii: 48_4_gr, 48_2_gs].....	44
GMAP/UGG/LLU/BV-101-C [Low Latency Streaming - AC8i: 32_1_gr, 16_1_gs].....	44
GMAP/UGG/LLU/BV-102-C [Low Latency Streaming - AC8i: 32_2_gr, 16_2_gs].....	44
GMAP/UGG/LLU/BV-103-C [Low Latency Streaming - AC8i: 48_1_gr, 16_1_gs].....	44
GMAP/UGG/LLU/BV-104-C [Low Latency Streaming - AC8i: 48_2_gr, 16_2_gs].....	44
GMAP/UGG/LLU/BV-79-C [Low Latency Streaming - AC8i: 32_1_gr, 32_1_gs].....	45
GMAP/UGG/LLU/BV-80-C [Low Latency Streaming - AC8i: 32_2_gr, 32_2_gs].....	45
GMAP/UGG/LLU/BV-27-C [Low Latency Streaming - AC8i: 48_1_gr, 32_1_gs].....	45
GMAP/UGG/LLU/BV-28-C [Low Latency Streaming - AC8i: 48_2_gr, 32_2_gs].....	45
GMAP/UGG/LLU/BV-29-C [Low Latency Streaming - AC8i: 48_1_gr, 48_1_gs].....	45
GMAP/UGG/LLU/BV-30-C [Low Latency Streaming - AC8i: 48_2_gr, 48_2_gs].....	45
GMAP/UGG/LLU/BV-31-C [Low Latency Streaming - AC8i: 48_3_gr, 32_1_gs].....	45
GMAP/UGG/LLU/BV-32-C [Low Latency Streaming - AC8i: 48_4_gr, 32_2_gs].....	45
GMAP/UGG/LLU/BV-105-C [Low Latency Streaming - AC8ii: 32_1_gr, 16_1_gs].....	45
GMAP/UGG/LLU/BV-106-C [Low Latency Streaming - AC8ii: 32_2_gr, 16_2_gs].....	45
GMAP/UGG/LLU/BV-107-C [Low Latency Streaming - AC8ii: 48_1_gr, 16_1_gs].....	45
GMAP/UGG/LLU/BV-108-C [Low Latency Streaming - AC8ii: 48_2_gr, 16_2_gs].....	45

GMAP/UGG/LLU/BV-81-C [Low Latency Streaming - AC8ii: 32_1_gr, 32_1_gs]	45
GMAP/UGG/LLU/BV-82-C [Low Latency Streaming - AC8ii: 32_2_gr, 32_2_gs]	45
GMAP/UGG/LLU/BV-33-C [Low Latency Streaming - AC8ii: 48_1_gr, 32_1_gs]	45
GMAP/UGG/LLU/BV-34-C [Low Latency Streaming - AC8ii: 48_2_gr, 32_2_gs]	46
GMAP/UGG/LLU/BV-35-C [Low Latency Streaming - AC8ii: 48_1_gr, 48_1_gs]	46
GMAP/UGG/LLU/BV-36-C [Low Latency Streaming - AC8ii: 48_2_gr, 48_2_gs]	46
GMAP/UGG/LLU/BV-37-C [Low Latency Streaming - AC8ii: 48_3_gr, 32_1_gs]	46
GMAP/UGG/LLU/BV-38-C [Low Latency Streaming - AC8ii: 48_4_gr, 32_2_gs]	46
GMAP/UGG/LLU/BV-109-C [Low Latency Streaming - AC11i: 32_1_gr, 16_1_gs]	46
GMAP/UGG/LLU/BV-110-C [Low Latency Streaming - AC11i: 32_2_gr, 16_2_gs]	46
GMAP/UGG/LLU/BV-111-C [Low Latency Streaming - AC11i: 48_1_gr, 16_1_gs]	46
GMAP/UGG/LLU/BV-112-C [Low Latency Streaming - AC11i: 48_2_gr, 16_2_gs]	46
GMAP/UGG/LLU/BV-83-C [Low Latency Streaming - AC11i: 32_1_gr, 32_1_gs]	46
GMAP/UGG/LLU/BV-84-C [Low Latency Streaming - AC11i: 32_2_gr, 32_2_gs]	46
GMAP/UGG/LLU/BV-39-C [Low Latency Streaming - AC11i: 48_1_gr, 32_1_gs]	46
GMAP/UGG/LLU/BV-40-C [Low Latency Streaming - AC11i: 48_2_gr, 32_2_gs]	46
GMAP/UGG/LLU/BV-43-C [Low Latency Streaming - AC11i: 48_3_gr, 32_1_gs]	46
GMAP/UGG/LLU/BV-44-C [Low Latency Streaming - AC11i: 48_4_gr, 32_2_gs]	46
GMAP/UGG/LLU/BV-113-C [Low Latency Streaming - AC11ii: 32_1_gr, 16_1_gs]	47
GMAP/UGG/LLU/BV-114-C [Low Latency Streaming - AC11ii: 32_2_gr, 16_2_gs]	47
GMAP/UGG/LLU/BV-115-C [Low Latency Streaming - AC11ii: 48_1_gr, 16_1_gs]	47
GMAP/UGG/LLU/BV-116-C [Low Latency Streaming - AC11ii: 48_2_gr, 16_2_gs]	47
GMAP/UGG/LLU/BV-85-C [Low Latency Streaming - AC11ii: 32_1_gr, 32_1_gs]	47
GMAP/UGG/LLU/BV-86-C [Low Latency Streaming - AC11ii: 32_2_gr, 32_2_gs]	47
GMAP/UGG/LLU/BV-45-C [Low Latency Streaming - AC11ii: 48_1_gr, 32_1_gs]	47
GMAP/UGG/LLU/BV-46-C [Low Latency Streaming - AC11ii: 48_2_gr, 32_2_gs]	47
GMAP/UGG/LLU/BV-49-C [Low Latency Streaming - AC11ii: 48_3_gr, 32_1_gs]	47
GMAP/UGG/LLU/BV-50-C [Low Latency Streaming - AC11ii: 48_4_gr, 32_2_gs]	47
4.2.2 Low Latency Audio Streaming – UGT	48
GMAP/UGT/LLU/BV-49-C [Low Latency Streaming - AC1: 32_1_gr]	49
GMAP/UGT/LLU/BV-50-C [Low Latency Streaming - AC1: 32_2_gr]	49
GMAP/UGT/LLU/BV-37-C [Low Latency Streaming - AC1: 48_1_gr]	49
GMAP/UGT/LLU/BV-38-C [Low Latency Streaming - AC1: 48_2_gr]	49
GMAP/UGT/LLU/BV-39-C [Low Latency Streaming - AC1: 48_3_gr]	49
GMAP/UGT/LLU/BV-40-C [Low Latency Streaming - AC1: 48_4_gr]	49
GMAP/UGT/LLU/BV-55-C [Low Latency Streaming - AC4: 32_1_gr]	49
GMAP/UGT/LLU/BV-56-C [Low Latency Streaming - AC4: 32_2_gr]	49
GMAP/UGT/LLU/BV-41-C [Low Latency Streaming - AC4: 48_1_gr]	49
GMAP/UGT/LLU/BV-42-C [Low Latency Streaming - AC4: 48_2_gr]	49
GMAP/UGT/LLU/BV-43-C [Low Latency Streaming - AC4: 48_3_gr]	49
GMAP/UGT/LLU/BV-44-C [Low Latency Streaming - AC4: 48_4_gr]	49
GMAP/UGT/LLU/BV-59-C [Low Latency Streaming - AC6i: 32_1_gr]	49
GMAP/UGT/LLU/BV-60-C [Low Latency Streaming - AC6i: 32_2_gr]	49
GMAP/UGT/LLU/BV-01-C [Low Latency Streaming - AC6i: 48_1_gr]	49
GMAP/UGT/LLU/BV-02-C [Low Latency Streaming - AC6i: 48_2_gr]	49
GMAP/UGT/LLU/BV-03-C [Low Latency Streaming - AC6i: 48_3_gr]	49
GMAP/UGT/LLU/BV-04-C [Low Latency Streaming - AC6i: 48_4_gr]	49
GMAP/UGT/LLU/BV-65-C [Low Latency Streaming - AC2: 16_1_gs]	51
GMAP/UGT/LLU/BV-66-C [Low Latency Streaming - AC2: 16_2_gs]	51
GMAP/UGT/LLU/BV-45-C [Low Latency Streaming - AC2: 32_1_gs]	51
GMAP/UGT/LLU/BV-46-C [Low Latency Streaming - AC2: 32_2_gs]	51
GMAP/UGT/LLU/BV-47-C [Low Latency Streaming - AC2: 48_1_gs]	51
GMAP/UGT/LLU/BV-48-C [Low Latency Streaming - AC2: 48_2_gs]	51
GMAP/UGT/LLU/BV-67-C [Low Latency Streaming - AC3: 32_1_gr, 16_1_gs]	51
GMAP/UGT/LLU/BV-68-C [Low Latency Streaming - AC3: 32_2_gr, 16_2_gs]	51
GMAP/UGT/LLU/BV-69-C [Low Latency Streaming - AC3: 48_1_gr, 16_1_gs]	51



GMAP/UGT/LLU/BV-70-C [Low Latency Streaming - AC3: 48_2_gr, 16_2_gs]	51
GMAP/UGT/LLU/BV-51-C [Low Latency Streaming - AC3: 32_1_gr, 32_1_gs]	51
GMAP/UGT/LLU/BV-52-C [Low Latency Streaming - AC3: 32_2_gr, 32_2_gs]	51
GMAP/UGT/LLU/BV-09-C [Low Latency Streaming - AC3: 48_1_gr, 32_1_gs]	51
GMAP/UGT/LLU/BV-10-C [Low Latency Streaming - AC3: 48_2_gr, 32_2_gs]	51
GMAP/UGT/LLU/BV-11-C [Low Latency Streaming - AC3: 48_1_gr, 48_1_gs]	51
GMAP/UGT/LLU/BV-12-C [Low Latency Streaming - AC3: 48_2_gr, 48_2_gs]	51
GMAP/UGT/LLU/BV-13-C [Low Latency Streaming - AC3: 48_3_gr, 32_1_gs]	51
GMAP/UGT/LLU/BV-14-C [Low Latency Streaming - AC3: 48_4_gr, 32_2_gs]	51
GMAP/UGT/LLU/BV-53-C [Low Latency Streaming - AC3: 48_3_gr, 48_1_gs]	51
GMAP/UGT/LLU/BV-54-C [Low Latency Streaming - AC3: 48_4_gr, 48_2_gs]	51
GMAP/UGT/LLU/BV-71-C [Low Latency Streaming - AC5: 32_1_gr, 16_1_gs]	51
GMAP/UGT/LLU/BV-72-C [Low Latency Streaming - AC5: 32_2_gr, 16_2_gs]	51
GMAP/UGT/LLU/BV-73-C [Low Latency Streaming - AC5: 48_1_gr, 16_1_gs]	51
GMAP/UGT/LLU/BV-74-C [Low Latency Streaming - AC5: 48_2_gr, 16_2_gs]	51
GMAP/UGT/LLU/BV-57-C [Low Latency Streaming - AC5: 32_1_gr, 32_1_gs]	51
GMAP/UGT/LLU/BV-58-C [Low Latency Streaming - AC5: 32_2_gr, 32_2_gs]	51
GMAP/UGT/LLU/BV-15-C [Low Latency Streaming - AC5: 48_1_gr, 32_1_gs]	52
GMAP/UGT/LLU/BV-16-C [Low Latency Streaming - AC5: 48_2_gr, 32_2_gs]	52
GMAP/UGT/LLU/BV-17-C [Low Latency Streaming - AC5: 48_1_gr, 48_1_gs]	52
GMAP/UGT/LLU/BV-18-C [Low Latency Streaming - AC5: 48_2_gr, 48_2_gs]	52
GMAP/UGT/LLU/BV-19-C [Low Latency Streaming - AC5: 48_3_gr, 32_1_gs]	52
GMAP/UGT/LLU/BV-20-C [Low Latency Streaming - AC5: 48_4_gr, 32_2_gs]	52
GMAP/UGT/LLU/BV-75-C [Low Latency Streaming - AC8i: 32_1_gr, 16_1_gs]	52
GMAP/UGT/LLU/BV-76-C [Low Latency Streaming - AC8i: 32_2_gr, 16_2_gs]	52
GMAP/UGT/LLU/BV-77-C [Low Latency Streaming - AC8i: 48_1_gr, 16_1_gs]	52
GMAP/UGT/LLU/BV-78-C [Low Latency Streaming - AC8i: 48_2_gr, 16_2_gs]	52
GMAP/UGT/LLU/BV-61-C [Low Latency Streaming - AC8i: 32_1_gr, 32_1_gs]	52
GMAP/UGT/LLU/BV-62-C [Low Latency Streaming - AC8i: 32_2_gr, 32_2_gs]	52
GMAP/UGT/LLU/BV-25-C [Low Latency Streaming - AC8i: 48_1_gr, 32_1_gs]	52
GMAP/UGT/LLU/BV-26-C [Low Latency Streaming - AC8i: 48_2_gr, 32_2_gs]	52
GMAP/UGT/LLU/BV-27-C [Low Latency Streaming - AC8i: 48_1_gr, 48_1_gs]	52
GMAP/UGT/LLU/BV-28-C [Low Latency Streaming - AC8i: 48_2_gr, 48_2_gs]	52
GMAP/UGT/LLU/BV-29-C [Low Latency Streaming - AC8i: 48_3_gr, 32_1_gs]	52
GMAP/UGT/LLU/BV-30-C [Low Latency Streaming - AC8i: 48_4_gr, 32_2_gs]	52
GMAP/UGT/LLU/BV-79-C [Low Latency Streaming - AC11i: 32_1_gr, 16_1_gs]	53
GMAP/UGT/LLU/BV-80-C [Low Latency Streaming - AC11i: 32_2_gr, 16_2_gs]	53
GMAP/UGT/LLU/BV-81-C [Low Latency Streaming - AC11i: 48_1_gr, 16_1_gs]	53
GMAP/UGT/LLU/BV-82-C [Low Latency Streaming - AC11i: 48_2_gr, 16_2_gs]	53
GMAP/UGT/LLU/BV-63-C [Low Latency Streaming - AC11i: 32_1_gr, 32_1_gs]	53
GMAP/UGT/LLU/BV-64-C [Low Latency Streaming - AC11i: 32_2_gr, 32_2_gs]	53
GMAP/UGT/LLU/BV-31-C [Low Latency Streaming - AC11i: 48_1_gr, 32_1_gs]	53
GMAP/UGT/LLU/BV-32-C [Low Latency Streaming - AC11i: 48_2_gr, 32_2_gs]	53
GMAP/UGT/LLU/BV-35-C [Low Latency Streaming - AC11i: 48_3_gr, 32_1_gs]	53
GMAP/UGT/LLU/BV-36-C [Low Latency Streaming - AC11i: 48_4_gr, 32_2_gs]	53
4.3 Low Latency Audio Streaming – Broadcast	54
4.3.1 Low Latency Audio Streaming – BGS	54
GMAP/BGS/LLB/BV-05-C [Low Latency Streaming - AC12: 48_1_g]	55
GMAP/BGS/LLB/BV-06-C [Low Latency Streaming - AC12: 48_2_g]	55
GMAP/BGS/LLB/BV-07-C [Low Latency Streaming - AC12: 48_3_g]	55
GMAP/BGS/LLB/BV-08-C [Low Latency Streaming - AC12: 48_4_g]	55
GMAP/BGS/LLB/BV-01-C [Low Latency Streaming - AC13: 48_1_g]	55
GMAP/BGS/LLB/BV-02-C [Low Latency Streaming - AC13: 48_2_g]	55
GMAP/BGS/LLB/BV-03-C [Low Latency Streaming - AC13: 48_3_g]	55
GMAP/BGS/LLB/BV-04-C [Low Latency Streaming - AC13: 48_4_g]	55
GMAP/BGS/LLB/BV-09-C [Low Latency Streaming - AC14: 48_1_g]	55



GMAP/BGS/LLB/BV-10-C [Low Latency Streaming - AC14: 48_2_g]	55
GMAP/BGS/LLB/BV-11-C [Low Latency Streaming - AC14: 48_3_g]	55
GMAP/BGS/LLB/BV-12-C [Low Latency Streaming - AC14: 48_4_g]	55
4.3.2 Low Latency Audio Streaming – BGR	56
GMAP/BGR/LLB/BV-13-C [Low Latency Streaming - AC12: 48_1_g]	57
GMAP/BGR/LLB/BV-14-C [Low Latency Streaming - AC12: 48_2_g]	57
GMAP/BGR/LLB/BV-15-C [Low Latency Streaming - AC12: 48_3_g]	57
GMAP/BGR/LLB/BV-16-C [Low Latency Streaming - AC12: 48_4_g]	57
GMAP/BGR/LLB/BV-01-C [Low Latency Streaming - AC13: 48_1_g]	57
GMAP/BGR/LLB/BV-02-C [Low Latency Streaming - AC13: 48_2_g]	57
GMAP/BGR/LLB/BV-03-C [Low Latency Streaming - AC13: 48_3_g]	57
GMAP/BGR/LLB/BV-04-C [Low Latency Streaming - AC13: 48_4_g]	57
GMAP/BGR/LLB/BV-09-C [Low Latency Streaming - AC13: 48_1_g, right and left]	57
GMAP/BGR/LLB/BV-10-C [Low Latency Streaming - AC13: 48_2_g, right and left]	57
GMAP/BGR/LLB/BV-11-C [Low Latency Streaming - AC13: 48_3_g, right and left]	57
GMAP/BGR/LLB/BV-12-C [Low Latency Streaming - AC13: 48_4_g, right and left]	57
GMAP/BGR/LLB/BV-17-C [Low Latency Streaming - AC14: 48_1_g]	57
GMAP/BGR/LLB/BV-18-C [Low Latency Streaming - AC14: 48_2_g]	58
GMAP/BGR/LLB/BV-19-C [Low Latency Streaming - AC14: 48_3_g]	58
GMAP/BGR/LLB/BV-20-C [Low Latency Streaming - AC14: 48_4_g]	58
4.4 Maximum latency	59
4.4.1 Audio In to SDU Sync max latency, INI to ACC	59
GMAP/UGG/MXLT/BV-55-C [Audio In to SDU Sync Latency - AC1: 32_1_gr]	60
GMAP/UGG/MXLT/BV-56-C [Audio In to SDU Sync Latency - AC1: 32_2_gr]	60
GMAP/UGG/MXLT/BV-37-C [Audio In to SDU Sync Latency - AC1: 48_1_gr]	60
GMAP/UGG/MXLT/BV-38-C [Audio In to SDU Sync Latency - AC1: 48_2_gr]	60
GMAP/UGG/MXLT/BV-39-C [Audio In to SDU Sync Latency - AC1: 48_3_gr]	60
GMAP/UGG/MXLT/BV-40-C [Audio In to SDU Sync Latency - AC1: 48_4_gr]	60
GMAP/UGG/MXLT/BV-128-C [Audio In to SDU Sync Latency - AC3: 32_1_gr, 16_1_gs]	60
GMAP/UGG/MXLT/BV-129-C [Audio In to SDU Sync Latency - AC3: 32_2_gr, 16_2_gs]	60
GMAP/UGG/MXLT/BV-130-C [Audio In to SDU Sync Latency - AC3: 48_1_gr, 16_1_gs]	60
GMAP/UGG/MXLT/BV-131-C [Audio In to SDU Sync Latency - AC3: 48_2_gr, 16_2_gs]	60
GMAP/UGG/MXLT/BV-57-C [Audio In to SDU Sync Latency - AC3: 32_1_gr, 32_1_gs]	60
GMAP/UGG/MXLT/BV-58-C [Audio In to SDU Sync Latency - AC3: 32_2_gr, 32_2_gs]	60
GMAP/UGG/MXLT/BV-01-C [Audio In to SDU Sync Latency - AC3: 48_1_gr, 32_1_gs]	60
GMAP/UGG/MXLT/BV-02-C [Audio In to SDU Sync Latency - AC3: 48_2_gr, 32_2_gs]	60
GMAP/UGG/MXLT/BV-45-C [Audio In to SDU Sync Latency - AC3: 48_1_gr, 48_1_gs]	60
GMAP/UGG/MXLT/BV-46-C [Audio In to SDU Sync Latency - AC3: 48_2_gr, 48_2_gs]	61
GMAP/UGG/MXLT/BV-03-C [Audio In to SDU Sync Latency - AC3: 48_3_gr, 32_1_gs]	61
GMAP/UGG/MXLT/BV-04-C [Audio In to SDU Sync Latency - AC3: 48_4_gr, 32_2_gs]	61
GMAP/UGG/MXLT/BV-59-C [Audio In to SDU Sync Latency - AC3: 48_3_gr, 48_1_gs]	61
GMAP/UGG/MXLT/BV-60-C [Audio In to SDU Sync Latency - AC3: 48_4_gr, 48_2_gs]	61
GMAP/UGG/MXLT/BV-61-C [Audio In to SDU Sync Latency - AC4: 32_1_gr]	61
GMAP/UGG/MXLT/BV-62-C [Audio In to SDU Sync Latency - AC4: 32_2_gr]	61
GMAP/UGG/MXLT/BV-41-C [Audio In to SDU Sync Latency - AC4: 48_1_gr]	61
GMAP/UGG/MXLT/BV-42-C [Audio In to SDU Sync Latency - AC4: 48_2_gr]	61
GMAP/UGG/MXLT/BV-43-C [Audio In to SDU Sync Latency - AC4: 48_3_gr]	61
GMAP/UGG/MXLT/BV-44-C [Audio In to SDU Sync Latency - AC4: 48_4_gr]	61
GMAP/UGG/MXLT/BV-132-C [Audio In to SDU Sync Latency - AC5: 32_1_gr, 16_1_gs]	61
GMAP/UGG/MXLT/BV-133-C [Audio In to SDU Sync Latency - AC5: 32_2_gr, 16_2_gs]	61
GMAP/UGG/MXLT/BV-134-C [Audio In to SDU Sync Latency - AC5: 48_1_gr, 16_1_gs]	61
GMAP/UGG/MXLT/BV-135-C [Audio In to SDU Sync Latency - AC5: 48_2_gr, 16_2_gs]	61
GMAP/UGG/MXLT/BV-63-C [Audio In to SDU Sync Latency - AC5: 32_1_gr, 32_1_gs]	62
GMAP/UGG/MXLT/BV-64-C [Audio In to SDU Sync Latency - AC5: 32_2_gr, 32_2_gs]	62
GMAP/UGG/MXLT/BV-05-C [Audio In to SDU Sync Latency - AC5: 48_1_gr, 32_1_gs]	62
GMAP/UGG/MXLT/BV-06-C [Audio In to SDU Sync Latency - AC5: 48_2_gr, 32_2_gs]	62



GMAP/UGG/MXLT/BV-47-C [Audio In to SDU Sync Latency - AC5: 48_1_gr, 48_1_gs]	62
GMAP/UGG/MXLT/BV-48-C [Audio In to SDU Sync Latency - AC5: 48_2_gr, 48_2_gs]	62
GMAP/UGG/MXLT/BV-07-C [Audio In to SDU Sync Latency - AC5: 48_3_gr, 32_1_gs]	62
GMAP/UGG/MXLT/BV-08-C [Audio In to SDU Sync Latency - AC5: 48_4_gr, 32_2_gs]	62
GMAP/UGG/MXLT/BV-65-C [Audio In to SDU Sync Latency - AC6i: 32_1_gr]	62
GMAP/UGG/MXLT/BV-66-C [Audio In to SDU Sync Latency - AC6i: 32_2_gr]	62
GMAP/UGG/MXLT/BV-29-C [Audio In to SDU Sync Latency - AC6i: 48_1_gr]	62
GMAP/UGG/MXLT/BV-30-C [Audio In to SDU Sync Latency - AC6i: 48_2_gr]	62
GMAP/UGG/MXLT/BV-31-C [Audio In to SDU Sync Latency - AC6i: 48_3_gr]	62
GMAP/UGG/MXLT/BV-32-C [Audio In to SDU Sync Latency - AC6i: 48_4_gr]	62
GMAP/UGG/MXLT/BV-67-C [Audio In to SDU Sync Latency - AC6ii: 32_1_gr]	62
GMAP/UGG/MXLT/BV-68-C [Audio In to SDU Sync Latency - AC6ii: 32_2_gr]	63
GMAP/UGG/MXLT/BV-33-C [Audio In to SDU Sync Latency - AC6ii: 48_1_gr]	63
GMAP/UGG/MXLT/BV-34-C [Audio In to SDU Sync Latency - AC6ii: 48_2_gr]	63
GMAP/UGG/MXLT/BV-35-C [Audio In to SDU Sync Latency - AC6ii: 48_3_gr]	63
GMAP/UGG/MXLT/BV-36-C [Audio In to SDU Sync Latency - AC6ii: 48_4_gr]	63
GMAP/UGG/MXLT/BV-136-C [Audio In to SDU Sync Latency - AC7ii: 32_1_gr, 16_1_gs]	63
GMAP/UGG/MXLT/BV-137-C [Audio In to SDU Sync Latency - AC7ii: 32_2_gr, 16_2_gs]	63
GMAP/UGG/MXLT/BV-138-C [Audio In to SDU Sync Latency - AC7ii: 48_1_gr, 16_1_gs]	63
GMAP/UGG/MXLT/BV-139-C [Audio In to SDU Sync Latency - AC7ii: 48_2_gr, 16_2_gs]	63
GMAP/UGG/MXLT/BV-69-C [Audio In to SDU Sync Latency - AC7ii: 32_1_gr, 32_1_gs]	63
GMAP/UGG/MXLT/BV-70-C [Audio In to SDU Sync Latency - AC7ii: 32_2_gr, 32_2_gs]	63
GMAP/UGG/MXLT/BV-09-C [Audio In to SDU Sync Latency - AC7ii: 48_1_gr, 32_1_gs]	63
GMAP/UGG/MXLT/BV-10-C [Audio In to SDU Sync Latency - AC7ii: 48_2_gr, 32_2_gs]	63
GMAP/UGG/MXLT/BV-49-C [Audio In to SDU Sync Latency - AC7ii: 48_1_gr, 48_1_gs]	63
GMAP/UGG/MXLT/BV-50-C [Audio In to SDU Sync Latency - AC7ii: 48_2_gr, 48_2_gs]	63
GMAP/UGG/MXLT/BV-11-C [Audio In to SDU Sync Latency - AC7ii: 48_3_gr, 32_1_gs]	64
GMAP/UGG/MXLT/BV-12-C [Audio In to SDU Sync Latency - AC7ii: 48_4_gr, 32_2_gs]	64
GMAP/UGG/MXLT/BV-71-C [Audio In to SDU Sync Latency - AC7ii: 48_3_gr, 48_1_gs]	64
GMAP/UGG/MXLT/BV-72-C [Audio In to SDU Sync Latency - AC7ii: 48_4_gr, 48_2_gs]	64
GMAP/UGG/MXLT/BV-140-C [Audio In to SDU Sync Latency - AC8i: 32_1_gr, 16_1_gs]	64
GMAP/UGG/MXLT/BV-141-C [Audio In to SDU Sync Latency - AC8i: 32_2_gr, 16_2_gs]	64
GMAP/UGG/MXLT/BV-142-C [Audio In to SDU Sync Latency - AC8i: 48_1_gr, 16_1_gs]	64
GMAP/UGG/MXLT/BV-143-C [Audio In to SDU Sync Latency - AC8i: 48_2_gr, 16_2_gs]	64
GMAP/UGG/MXLT/BV-73-C [Audio In to SDU Sync Latency - AC8i: 32_1_gr, 32_1_gs]	64
GMAP/UGG/MXLT/BV-74-C [Audio In to SDU Sync Latency - AC8i: 32_2_gr, 32_2_gs]	64
GMAP/UGG/MXLT/BV-13-C [Audio In to SDU Sync Latency - AC8i: 48_1_gr, 32_1_gs]	64
GMAP/UGG/MXLT/BV-14-C [Audio In to SDU Sync Latency - AC8i: 48_2_gr, 32_2_gs]	64
GMAP/UGG/MXLT/BV-51-C [Audio In to SDU Sync Latency - AC8i: 48_1_gr, 48_1_gs]	64
GMAP/UGG/MXLT/BV-52-C [Audio In to SDU Sync Latency - AC8i: 48_2_gr, 48_2_gs]	64
GMAP/UGG/MXLT/BV-15-C [Audio In to SDU Sync Latency - AC8i: 48_3_gr, 32_1_gs]	64
GMAP/UGG/MXLT/BV-16-C [Audio In to SDU Sync Latency - AC8i: 48_4_gr, 32_2_gs]	65
GMAP/UGG/MXLT/BV-144-C [Audio In to SDU Sync Latency - AC8ii: 32_1_gr, 16_1_gs]	65
GMAP/UGG/MXLT/BV-145-C [Audio In to SDU Sync Latency - AC8ii: 32_2_gr, 16_2_gs]	65
GMAP/UGG/MXLT/BV-146-C [Audio In to SDU Sync Latency - AC8ii: 48_1_gr, 16_1_gs]	65
GMAP/UGG/MXLT/BV-147-C [Audio In to SDU Sync Latency - AC8ii: 48_2_gr, 16_2_gs]	65
GMAP/UGG/MXLT/BV-75-C [Audio In to SDU Sync Latency - AC8ii: 32_1_gr, 32_1_gs]	65
GMAP/UGG/MXLT/BV-76-C [Audio In to SDU Sync Latency - AC8ii: 32_2_gr, 32_2_gs]	65
GMAP/UGG/MXLT/BV-17-C [Audio In to SDU Sync Latency - AC8ii: 48_1_gr, 32_1_gs]	65
GMAP/UGG/MXLT/BV-18-C [Audio In to SDU Sync Latency - AC8ii: 48_2_gr, 32_2_gs]	65
GMAP/UGG/MXLT/BV-53-C [Audio In to SDU Sync Latency - AC8ii: 48_1_gr, 48_1_gs]	65
GMAP/UGG/MXLT/BV-54-C [Audio In to SDU Sync Latency - AC8ii: 48_2_gr, 48_2_gs]	65
GMAP/UGG/MXLT/BV-19-C [Audio In to SDU Sync Latency - AC8ii: 48_3_gr, 32_1_gs]	65
GMAP/UGG/MXLT/BV-20-C [Audio In to SDU Sync Latency - AC8ii: 48_4_gr, 32_2_gs]	65
GMAP/UGG/MXLT/BV-170-C [Audio In to SDU Sync Latency - AC11i: 32_1_gr, 16_1_gs]	65
GMAP/UGG/MXLT/BV-171-C [Audio In to SDU Sync Latency - AC11i: 32_2_gr, 16_2_gs]	65



GMAP/UGG/MXLT/BV-172-C [Audio In to SDU Sync Latency - AC11i: 48_1_gr, 16_1_gs]	66
GMAP/UGG/MXLT/BV-173-C [Audio In to SDU Sync Latency - AC11i: 48_2_gr, 16_2_gs]	66
GMAP/UGG/MXLT/BV-174-C [Audio In to SDU Sync Latency - AC11i: 32_1_gr, 32_1_gs]	66
GMAP/UGG/MXLT/BV-175-C [Audio In to SDU Sync Latency - AC11i: 32_2_gr, 32_2_gs]	66
GMAP/UGG/MXLT/BV-176-C [Audio In to SDU Sync Latency - AC11i: 48_1_gr, 32_1_gs]	66
GMAP/UGG/MXLT/BV-177-C [Audio In to SDU Sync Latency - AC11i: 48_2_gr, 32_2_gs]	66
GMAP/UGG/MXLT/BV-178-C [Audio In to SDU Sync Latency - AC11i: 48_3_gr, 32_1_gs]	66
GMAP/UGG/MXLT/BV-179-C [Audio In to SDU Sync Latency - AC11i: 48_4_gr, 32_2_gs]	66
GMAP/UGG/MXLT/BV-180-C [Audio In to SDU Sync Latency - AC11ii: 32_1_gr, 16_1_gs]	66
GMAP/UGG/MXLT/BV-181-C [Audio In to SDU Sync Latency - AC11ii: 32_2_gr, 16_2_gs]	66
GMAP/UGG/MXLT/BV-182-C [Audio In to SDU Sync Latency - AC11ii: 48_1_gr, 16_1_gs]	66
GMAP/UGG/MXLT/BV-183-C [Audio In to SDU Sync Latency - AC11ii: 48_2_gr, 16_2_gs]	66
GMAP/UGG/MXLT/BV-184-C [Audio In to SDU Sync Latency - AC11ii: 32_1_gr, 32_1_gs]	66
GMAP/UGG/MXLT/BV-185-C [Audio In to SDU Sync Latency - AC11ii: 32_2_gr, 32_2_gs]	66
GMAP/UGG/MXLT/BV-186-C [Audio In to SDU Sync Latency - AC11ii: 48_1_gr, 32_1_gs]	66
GMAP/UGG/MXLT/BV-187-C [Audio In to SDU Sync Latency - AC11ii: 48_2_gr, 32_2_gs]	67
GMAP/UGG/MXLT/BV-188-C [Audio In to SDU Sync Latency - AC11ii: 48_3_gr, 32_1_gs]	67
GMAP/UGG/MXLT/BV-189-C [Audio In to SDU Sync Latency - AC11ii: 48_4_gr, 32_2_gs]	67
GMAP/BGS/MXLT/BV-05-C [Audio In to SDU Sync Latency - AC12: 48_1_g]	69
GMAP/BGS/MXLT/BV-06-C [Audio In to SDU Sync Latency - AC12: 48_2_g]	69
GMAP/BGS/MXLT/BV-07-C [Audio In to SDU Sync Latency - AC12: 48_3_g]	69
GMAP/BGS/MXLT/BV-08-C [Audio In to SDU Sync Latency - AC12: 48_4_g]	69
GMAP/BGS/MXLT/BV-01-C [Audio In to SDU Sync Latency - AC13: 48_1_g]	69
GMAP/BGS/MXLT/BV-02-C [Audio In to SDU Sync Latency - AC13: 48_2_g]	69
GMAP/BGS/MXLT/BV-03-C [Audio In to SDU Sync Latency - AC13: 48_3_g]	69
GMAP/BGS/MXLT/BV-04-C [Audio In to SDU Sync Latency - AC13: 48_4_g]	69
GMAP/BGS/MXLT/BV-09-C [Audio In to SDU Sync Latency - AC14: 48_1_g]	69
GMAP/BGS/MXLT/BV-10-C [Audio In to SDU Sync Latency - AC14: 48_2_g]	69
GMAP/BGS/MXLT/BV-11-C [Audio In to SDU Sync Latency - AC14: 48_3_g]	69
GMAP/BGS/MXLT/BV-12-C [Audio In to SDU Sync Latency - AC14: 48_4_g]	69
4.4.2 SDU Sync to Audio Out max latency, INI to ACC	70
GMAP/UGT/MXLT/BV-03-C [SDU Sync to Audio Out Latency - AC1: 32_1_gr]	71
GMAP/UGT/MXLT/BV-04-C [SDU Sync to Audio Out Latency - AC1: 32_2_gr]	71
GMAP/UGT/MXLT/BV-36-C [SDU Sync to Audio Out Latency - AC1: 48_1_gr]	71
GMAP/UGT/MXLT/BV-37-C [SDU Sync to Audio Out Latency - AC1: 48_2_gr]	71
GMAP/UGT/MXLT/BV-38-C [SDU Sync to Audio Out Latency - AC1: 48_3_gr]	71
GMAP/UGT/MXLT/BV-39-C [SDU Sync to Audio Out Latency - AC1: 48_4_gr]	71
GMAP/UGT/MXLT/BV-110-C [SDU Sync to Audio Out Latency - AC3: 32_1_gr, 16_1_gs]	71
GMAP/UGT/MXLT/BV-111-C [SDU Sync to Audio Out Latency - AC3: 32_2_gr, 16_2_gs]	71
GMAP/UGT/MXLT/BV-112-C [SDU Sync to Audio Out Latency - AC3: 48_1_gr, 16_1_gs]	71
GMAP/UGT/MXLT/BV-113-C [SDU Sync to Audio Out Latency - AC3: 48_2_gr, 16_2_gs]	71
GMAP/UGT/MXLT/BV-05-C [SDU Sync to Audio Out Latency - AC3: 32_1_gr, 32_1_gs]	71
GMAP/UGT/MXLT/BV-06-C [SDU Sync to Audio Out Latency - AC3: 32_2_gr, 32_2_gs]	71
GMAP/UGT/MXLT/BV-44-C [SDU Sync to Audio Out Latency - AC3: 48_1_gr, 32_1_gs]	71
GMAP/UGT/MXLT/BV-45-C [SDU Sync to Audio Out Latency - AC3: 48_2_gr, 32_2_gs]	71
GMAP/UGT/MXLT/BV-52-C [SDU Sync to Audio Out Latency - AC3: 48_1_gr, 48_1_gs]	71
GMAP/UGT/MXLT/BV-53-C [SDU Sync to Audio Out Latency - AC3: 48_2_gr, 48_2_gs]	71
GMAP/UGT/MXLT/BV-46-C [SDU Sync to Audio Out Latency - AC3: 48_3_gr, 32_1_gs]	71
GMAP/UGT/MXLT/BV-47-C [SDU Sync to Audio Out Latency - AC3: 48_4_gr, 32_2_gs]	71
GMAP/UGT/MXLT/BV-07-C [SDU Sync to Audio Out Latency - AC3: 48_3_gr, 48_1_gs]	71
GMAP/UGT/MXLT/BV-08-C [SDU Sync to Audio Out Latency - AC3: 48_4_gr, 48_2_gs]	71
GMAP/UGT/MXLT/BV-09-C [SDU Sync to Audio Out Latency - AC4: 32_1_gr]	71
GMAP/UGT/MXLT/BV-10-C [SDU Sync to Audio Out Latency - AC4: 32_2_gr]	71
GMAP/UGT/MXLT/BV-48-C [SDU Sync to Audio Out Latency - AC4: 48_1_gr]	71
GMAP/UGT/MXLT/BV-49-C [SDU Sync to Audio Out Latency - AC4: 48_2_gr]	71
GMAP/UGT/MXLT/BV-50-C [SDU Sync to Audio Out Latency - AC4: 48_3_gr]	71

GMAP/UGT/MXLT/BV-51-C [SDU Sync to Audio Out Latency - AC4: 48_4_gr].....72

GMAP/UGT/MXLT/BV-114-C [SDU Sync to Audio Out Latency - AC5: 32_1_gr, 16_1_gs].....72

GMAP/UGT/MXLT/BV-115-C [SDU Sync to Audio Out Latency - AC5: 32_2_gr, 16_2_gs].....72

GMAP/UGT/MXLT/BV-116-C [SDU Sync to Audio Out Latency - AC5: 48_1_gr, 16_1_gs].....72

GMAP/UGT/MXLT/BV-117-C [SDU Sync to Audio Out Latency - AC5: 48_2_gr, 16_2_gs].....72

GMAP/UGT/MXLT/BV-11-C [SDU Sync to Audio Out Latency - AC5: 32_1_gr, 32_1_gs].....72

GMAP/UGT/MXLT/BV-12-C [SDU Sync to Audio Out Latency - AC5: 32_2_gr, 32_2_gs].....72

GMAP/UGT/MXLT/BV-20-C [SDU Sync to Audio Out Latency - AC5: 48_1_gr, 32_1_gs].....72

GMAP/UGT/MXLT/BV-21-C [SDU Sync to Audio Out Latency - AC5: 48_2_gr, 32_2_gs].....72

GMAP/UGT/MXLT/BV-54-C [SDU Sync to Audio Out Latency - AC5: 48_1_gr, 48_1_gs].....72

GMAP/UGT/MXLT/BV-55-C [SDU Sync to Audio Out Latency - AC5: 48_2_gr, 48_2_gs].....72

GMAP/UGT/MXLT/BV-22-C [SDU Sync to Audio Out Latency - AC5: 48_3_gr, 32_1_gs].....72

GMAP/UGT/MXLT/BV-23-C [SDU Sync to Audio Out Latency - AC5: 48_4_gr, 32_2_gs].....72

GMAP/UGT/MXLT/BV-13-C [SDU Sync to Audio Out Latency - AC6i: 32_1_gr].....72

GMAP/UGT/MXLT/BV-14-C [SDU Sync to Audio Out Latency - AC6i: 32_2_gr].....72

GMAP/UGT/MXLT/BV-32-C [SDU Sync to Audio Out Latency - AC6i: 48_1_gr].....72

GMAP/UGT/MXLT/BV-33-C [SDU Sync to Audio Out Latency - AC6i: 48_2_gr].....72

GMAP/UGT/MXLT/BV-34-C [SDU Sync to Audio Out Latency - AC6i: 48_3_gr].....72

GMAP/UGT/MXLT/BV-35-C [SDU Sync to Audio Out Latency - AC6i: 48_4_gr].....72

GMAP/UGT/MXLT/BV-118-C [SDU Sync to Audio Out Latency - AC8i: 32_1_gr, 16_1_gs].....72

GMAP/UGT/MXLT/BV-119-C [SDU Sync to Audio Out Latency - AC8i: 32_2_gr, 16_2_gs].....73

GMAP/UGT/MXLT/BV-120-C [SDU Sync to Audio Out Latency - AC8i: 48_1_gr, 16_1_gs].....73

GMAP/UGT/MXLT/BV-121-C [SDU Sync to Audio Out Latency - AC8i: 48_2_gr, 16_2_gs].....73

GMAP/UGT/MXLT/BV-15-C [SDU Sync to Audio Out Latency - AC8i: 32_1_gr, 32_1_gs].....73

GMAP/UGT/MXLT/BV-16-C [SDU Sync to Audio Out Latency - AC8i: 32_2_gr, 32_2_gs].....73

GMAP/UGT/MXLT/BV-24-C [SDU Sync to Audio Out Latency - AC8i: 48_1_gr, 32_1_gs].....73

GMAP/UGT/MXLT/BV-25-C [SDU Sync to Audio Out Latency - AC8i: 48_2_gr, 32_2_gs].....73

GMAP/UGT/MXLT/BV-01-C [SDU Sync to Audio Out Latency - AC8i: 48_1_gr, 48_1_gs].....73

GMAP/UGT/MXLT/BV-02-C [SDU Sync to Audio Out Latency - AC8i: 48_2_gr, 48_2_gs].....73

GMAP/UGT/MXLT/BV-26-C [SDU Sync to Audio Out Latency - AC8i: 48_3_gr, 32_1_gs].....73

GMAP/UGT/MXLT/BV-27-C [SDU Sync to Audio Out Latency - AC8i: 48_4_gr, 32_2_gs].....73

GMAP/UGT/MXLT/BV-136-C [SDU Sync to Audio Out Latency - AC11i: 32_1_gr, 16_1_gs].....73

GMAP/UGT/MXLT/BV-137-C [SDU Sync to Audio Out Latency - AC11i: 32_2_gr, 16_2_gs].....73

GMAP/UGT/MXLT/BV-138-C [SDU Sync to Audio Out Latency - AC11i: 48_1_gr, 16_1_gs].....73

GMAP/UGT/MXLT/BV-139-C [SDU Sync to Audio Out Latency - AC11i: 48_2_gr, 16_2_gs].....73

GMAP/UGT/MXLT/BV-140-C [SDU Sync to Audio Out Latency - AC11i: 32_1_gr, 32_1_gs].....74

GMAP/UGT/MXLT/BV-141-C [SDU Sync to Audio Out Latency - AC11i: 32_2_gr, 32_2_gs].....74

GMAP/UGT/MXLT/BV-142-C [SDU Sync to Audio Out Latency - AC11i: 48_1_gr, 32_1_gs].....74

GMAP/UGT/MXLT/BV-143-C [SDU Sync to Audio Out Latency - AC11i: 48_2_gr, 32_2_gs].....74

GMAP/UGT/MXLT/BV-144-C [SDU Sync to Audio Out Latency - AC11i: 48_3_gr, 32_1_gs].....74

GMAP/UGT/MXLT/BV-145-C [SDU Sync to Audio Out Latency - AC11i: 48_4_gr, 32_2_gs].....74

GMAP/BGR/MXLT/BV-05-C [SDU Sync to Audio Out Latency - AC12: 48_1_g].....76

GMAP/BGR/MXLT/BV-06-C [SDU Sync to Audio Out Latency - AC12: 48_2_g].....76

GMAP/BGR/MXLT/BV-07-C [SDU Sync to Audio Out Latency - AC12: 48_3_g].....76

GMAP/BGR/MXLT/BV-08-C [SDU Sync to Audio Out Latency - AC12: 48_4_g].....76

GMAP/BGR/MXLT/BV-01-C [SDU Sync to Audio Out Latency - AC13: 48_1_g].....76

GMAP/BGR/MXLT/BV-02-C [SDU Sync to Audio Out Latency - AC13: 48_2_g].....76

GMAP/BGR/MXLT/BV-03-C [SDU Sync to Audio Out Latency - AC13: 48_3_g].....76

GMAP/BGR/MXLT/BV-04-C [SDU Sync to Audio Out Latency - AC13: 48_4_g].....76

GMAP/BGR/MXLT/BV-09-C [SDU Sync to Audio Out Latency - AC14: 48_1_g].....76

GMAP/BGR/MXLT/BV-10-C [SDU Sync to Audio Out Latency - AC14: 48_2_g].....76

GMAP/BGR/MXLT/BV-11-C [SDU Sync to Audio Out Latency - AC14: 48_3_g].....76

GMAP/BGR/MXLT/BV-12-C [SDU Sync to Audio Out Latency - AC14: 48_4_g].....76

4.4.3 Max latency, UGT to UGG77

GMAP/UGT/MXLT/BV-122-C [Audio In to SDU Sync Latency - AC2: 16_1_gs].....78

GMAP/UGT/MXLT/BV-123-C [Audio In to SDU Sync Latency - AC2: 16_2_gs].....78



GMAP/UGT/MXLT/BV-80-C [Audio In to SDU Sync Latency - AC2: 32_1_gs].....	78
GMAP/UGT/MXLT/BV-81-C [Audio In to SDU Sync Latency - AC2: 32_2_gs].....	78
GMAP/UGT/MXLT/BV-82-C [Audio In to SDU Sync Latency - AC2: 48_1_gs].....	78
GMAP/UGT/MXLT/BV-83-C [Audio In to SDU Sync Latency - AC2: 48_2_gs].....	78
GMAP/UGT/MXLT/BV-124-C [Audio In to SDU Sync Latency - AC3: 32_1_gr, 16_1_gs].....	78
GMAP/UGT/MXLT/BV-125-C [Audio In to SDU Sync Latency - AC3: 32_2_gr, 16_2_gs].....	78
GMAP/UGT/MXLT/BV-126-C [Audio In to SDU Sync Latency - AC3: 48_1_gr, 16_1_gs].....	78
GMAP/UGT/MXLT/BV-127-C [Audio In to SDU Sync Latency - AC3: 48_2_gr, 16_2_gs].....	78
GMAP/UGT/MXLT/BV-84-C [Audio In to SDU Sync Latency - AC3: 32_1_gr, 32_1_gs].....	78
GMAP/UGT/MXLT/BV-85-C [Audio In to SDU Sync Latency - AC3: 32_2_gr, 32_2_gs].....	78
GMAP/UGT/MXLT/BV-86-C [Audio In to SDU Sync Latency - AC3: 48_1_gr, 32_1_gs].....	78
GMAP/UGT/MXLT/BV-87-C [Audio In to SDU Sync Latency - AC3: 48_2_gr, 32_2_gs].....	78
GMAP/UGT/MXLT/BV-88-C [Audio In to SDU Sync Latency - AC3: 48_1_gr, 48_1_gs].....	78
GMAP/UGT/MXLT/BV-89-C [Audio In to SDU Sync Latency - AC3: 48_2_gr, 48_2_gs].....	78
GMAP/UGT/MXLT/BV-90-C [Audio In to SDU Sync Latency - AC3: 48_3_gr, 32_1_gs].....	78
GMAP/UGT/MXLT/BV-91-C [Audio In to SDU Sync Latency - AC3: 48_4_gr, 32_2_gs].....	78
GMAP/UGT/MXLT/BV-92-C [Audio In to SDU Sync Latency - AC3: 48_3_gr, 48_1_gs].....	78
GMAP/UGT/MXLT/BV-93-C [Audio In to SDU Sync Latency - AC3: 48_4_gr, 48_2_gs].....	78
GMAP/UGT/MXLT/BV-128-C [Audio In to SDU Sync Latency - AC5: 32_1_gr, 16_1_gs].....	78
GMAP/UGT/MXLT/BV-129-C [Audio In to SDU Sync Latency - AC5: 32_2_gr, 16_2_gs].....	78
GMAP/UGT/MXLT/BV-130-C [Audio In to SDU Sync Latency - AC5: 48_1_gr, 16_1_gs].....	78
GMAP/UGT/MXLT/BV-131-C [Audio In to SDU Sync Latency - AC5: 48_2_gr, 16_2_gs].....	78
GMAP/UGT/MXLT/BV-94-C [Audio In to SDU Sync Latency - AC5: 32_1_gr, 32_1_gs].....	78
GMAP/UGT/MXLT/BV-95-C [Audio In to SDU Sync Latency - AC5: 32_2_gr, 32_2_gs].....	79
GMAP/UGT/MXLT/BV-96-C [Audio In to SDU Sync Latency - AC5: 48_1_gr, 32_1_gs].....	79
GMAP/UGT/MXLT/BV-97-C [Audio In to SDU Sync Latency - AC5: 48_2_gr, 32_2_gs].....	79
GMAP/UGT/MXLT/BV-98-C [Audio In to SDU Sync Latency - AC5: 48_1_gr, 48_1_gs].....	79
GMAP/UGT/MXLT/BV-99-C [Audio In to SDU Sync Latency - AC5: 48_2_gr, 48_2_gs].....	79
GMAP/UGT/MXLT/BV-100-C [Audio In to SDU Sync Latency - AC5: 48_3_gr, 32_1_gs].....	79
GMAP/UGT/MXLT/BV-101-C [Audio In to SDU Sync Latency - AC5: 48_4_gr, 32_2_gs].....	79
GMAP/UGT/MXLT/BV-132-C [Audio In to SDU Sync Latency - AC8i: 32_1_gr, 16_1_gs].....	79
GMAP/UGT/MXLT/BV-133-C [Audio In to SDU Sync Latency - AC8i: 32_2_gr, 16_2_gs].....	79
GMAP/UGT/MXLT/BV-134-C [Audio In to SDU Sync Latency - AC8i: 48_1_gr, 16_1_gs].....	79
GMAP/UGT/MXLT/BV-135-C [Audio In to SDU Sync Latency - AC8i: 48_2_gr, 16_2_gs].....	79
GMAP/UGT/MXLT/BV-102-C [Audio In to SDU Sync Latency - AC8i: 32_1_gr, 32_1_gs].....	79
GMAP/UGT/MXLT/BV-103-C [Audio In to SDU Sync Latency - AC8i: 32_2_gr, 32_2_gs].....	79
GMAP/UGT/MXLT/BV-104-C [Audio In to SDU Sync Latency - AC8i: 48_1_gr, 32_1_gs].....	79
GMAP/UGT/MXLT/BV-105-C [Audio In to SDU Sync Latency - AC8i: 48_2_gr, 32_2_gs].....	79
GMAP/UGT/MXLT/BV-106-C [Audio In to SDU Sync Latency - AC8i: 48_1_gr, 48_1_gs].....	79
GMAP/UGT/MXLT/BV-107-C [Audio In to SDU Sync Latency - AC8i: 48_2_gr, 48_2_gs].....	79
GMAP/UGT/MXLT/BV-108-C [Audio In to SDU Sync Latency - AC8i: 48_3_gr, 32_1_gs].....	79
GMAP/UGT/MXLT/BV-109-C [Audio In to SDU Sync Latency - AC8i: 48_4_gr, 32_2_gs].....	80
GMAP/UGT/MXLT/BV-146-C [Audio In to SDU Sync Latency - AC11i: 32_1_gr, 16_1_gs].....	80
GMAP/UGT/MXLT/BV-147-C [Audio In to SDU Sync Latency - AC11i: 32_2_gr, 16_2_gs].....	80
GMAP/UGT/MXLT/BV-148-C [Audio In to SDU Sync Latency - AC11i: 48_1_gr, 16_1_gs].....	80
GMAP/UGT/MXLT/BV-149-C [Audio In to SDU Sync Latency - AC11i: 48_2_gr, 16_2_gs].....	80
GMAP/UGT/MXLT/BV-150-C [Audio In to SDU Sync Latency - AC11i: 32_1_gr, 32_1_gs].....	80
GMAP/UGT/MXLT/BV-151-C [Audio In to SDU Sync Latency - AC11i: 32_2_gr, 32_2_gs].....	80
GMAP/UGT/MXLT/BV-152-C [Audio In to SDU Sync Latency - AC11i: 48_1_gr, 32_1_gs].....	80
GMAP/UGT/MXLT/BV-153-C [Audio In to SDU Sync Latency - AC11i: 48_2_gr, 32_2_gs].....	80
GMAP/UGT/MXLT/BV-154-C [Audio In to SDU Sync Latency - AC11i: 48_3_gr, 32_1_gs].....	80
GMAP/UGT/MXLT/BV-155-C [Audio In to SDU Sync Latency - AC11i: 48_4_gr, 32_2_gs].....	80
GMAP/UGG/MXLT/BV-148-C [SDU Sync to Audio Out Latency - AC2: 16_1_gs].....	82
GMAP/UGG/MXLT/BV-149-C [SDU Sync to Audio Out Latency - AC2: 16_2_gs].....	82
GMAP/UGG/MXLT/BV-80-C [SDU Sync to Audio Out Latency - AC2: 32_1_gs].....	82
GMAP/UGG/MXLT/BV-81-C [SDU Sync to Audio Out Latency - AC2: 32_2_gs].....	82



GMAP/UGG/MXLT/BV-82-C [SDU Sync to Audio Out Latency - AC2: 48_1_gs]	82
GMAP/UGG/MXLT/BV-83-C [SDU Sync to Audio Out Latency - AC2: 48_2_gs]	82
GMAP/UGG/MXLT/BV-150-C [SDU Sync to Audio Out Latency - AC3: 32_1_gr, 16_1_gs]	82
GMAP/UGG/MXLT/BV-151-C [SDU Sync to Audio Out Latency - AC3: 32_2_gr, 16_2_gs]	82
GMAP/UGG/MXLT/BV-152-C [SDU Sync to Audio Out Latency - AC3: 48_1_gr, 16_1_gs]	82
GMAP/UGG/MXLT/BV-153-C [SDU Sync to Audio Out Latency - AC3: 48_2_gr, 16_2_gs]	82
GMAP/UGG/MXLT/BV-84-C [SDU Sync to Audio Out Latency - AC3: 32_1_gr, 32_1_gs]	82
GMAP/UGG/MXLT/BV-85-C [SDU Sync to Audio Out Latency - AC3: 32_2_gr, 32_2_gs]	82
GMAP/UGG/MXLT/BV-86-C [SDU Sync to Audio Out Latency - AC3: 48_1_gr, 32_1_gs]	82
GMAP/UGG/MXLT/BV-87-C [SDU Sync to Audio Out Latency - AC3: 48_2_gr, 32_2_gs]	82
GMAP/UGG/MXLT/BV-88-C [SDU Sync to Audio Out Latency - AC3: 48_1_gr, 48_1_gs]	82
GMAP/UGG/MXLT/BV-89-C [SDU Sync to Audio Out Latency - AC3: 48_2_gr, 48_2_gs]	83
GMAP/UGG/MXLT/BV-90-C [SDU Sync to Audio Out Latency - AC3: 48_3_gr, 32_1_gs]	83
GMAP/UGG/MXLT/BV-91-C [SDU Sync to Audio Out Latency - AC3: 48_4_gr, 32_2_gs]	83
GMAP/UGG/MXLT/BV-92-C [SDU Sync to Audio Out Latency - AC3: 48_3_gr, 48_1_gs]	83
GMAP/UGG/MXLT/BV-93-C [SDU Sync to Audio Out Latency - AC3: 48_4_gr, 48_2_gs]	83
GMAP/UGG/MXLT/BV-154-C [SDU Sync to Audio Out Latency - AC5: 32_1_gr, 16_1_gs]	83
GMAP/UGG/MXLT/BV-155-C [SDU Sync to Audio Out Latency - AC5: 32_2_gr, 16_2_gs]	83
GMAP/UGG/MXLT/BV-156-C [SDU Sync to Audio Out Latency - AC5: 48_1_gr, 16_1_gs]	83
GMAP/UGG/MXLT/BV-157-C [SDU Sync to Audio Out Latency - AC5: 48_2_gr, 16_2_gs]	83
GMAP/UGG/MXLT/BV-94-C [SDU Sync to Audio Out Latency - AC5: 32_1_gr, 32_1_gs]	83
GMAP/UGG/MXLT/BV-95-C [SDU Sync to Audio Out Latency - AC5: 32_2_gr, 32_2_gs]	83
GMAP/UGG/MXLT/BV-96-C [SDU Sync to Audio Out Latency - AC5: 48_1_gr, 32_1_gs]	83
GMAP/UGG/MXLT/BV-97-C [SDU Sync to Audio Out Latency - AC5: 48_2_gr, 32_2_gs]	83
GMAP/UGG/MXLT/BV-98-C [SDU Sync to Audio Out Latency - AC5: 48_1_gr, 48_1_gs]	83
GMAP/UGG/MXLT/BV-99-C [SDU Sync to Audio Out Latency - AC5: 48_2_gr, 48_2_gs]	83
GMAP/UGG/MXLT/BV-100-C [SDU Sync to Audio Out Latency - AC5: 48_3_gr, 32_1_gs]	84
GMAP/UGG/MXLT/BV-101-C [SDU Sync to Audio Out Latency - AC5: 48_4_gr, 32_2_gs]	84
GMAP/UGG/MXLT/BV-158-C [SDU Sync to Audio Out Latency - AC7(ii): 32_1_gr, 16_1_gs]	84
GMAP/UGG/MXLT/BV-159-C [SDU Sync to Audio Out Latency - AC7(ii): 32_2_gr, 16_2_gs]	84
GMAP/UGG/MXLT/BV-160-C [SDU Sync to Audio Out Latency - AC7(ii): 48_1_gr, 16_1_gs]	84
GMAP/UGG/MXLT/BV-161-C [SDU Sync to Audio Out Latency - AC7(ii): 48_2_gr, 16_2_gs]	84
GMAP/UGG/MXLT/BV-102-C [SDU Sync to Audio Out Latency - AC7(ii): 32_1_gr, 32_1_gs]	84
GMAP/UGG/MXLT/BV-103-C [SDU Sync to Audio Out Latency - AC7(ii): 32_2_gr, 32_2_gs]	84
GMAP/UGG/MXLT/BV-104-C [SDU Sync to Audio Out Latency - AC7(ii): 48_1_gr, 32_1_gs]	84
GMAP/UGG/MXLT/BV-105-C [SDU Sync to Audio Out Latency - AC7(ii): 48_2_gr, 32_2_gs]	84
GMAP/UGG/MXLT/BV-106-C [SDU Sync to Audio Out Latency - AC7(ii): 48_1_gr, 48_1_gs]	84
GMAP/UGG/MXLT/BV-107-C [SDU Sync to Audio Out Latency - AC7(ii): 48_2_gr, 48_2_gs]	84
GMAP/UGG/MXLT/BV-108-C [SDU Sync to Audio Out Latency - AC7(ii): 48_3_gr, 32_1_gs]	84
GMAP/UGG/MXLT/BV-109-C [SDU Sync to Audio Out Latency - AC7(ii): 48_4_gr, 32_2_gs]	84
GMAP/UGG/MXLT/BV-110-C [SDU Sync to Audio Out Latency - AC7(ii): 48_3_gr, 48_1_gs]	84
GMAP/UGG/MXLT/BV-111-C [SDU Sync to Audio Out Latency - AC7(ii): 48_4_gr, 48_2_gs]	85
GMAP/UGG/MXLT/BV-162-C [SDU Sync to Audio Out Latency - AC8i: 32_1_gr, 16_1_gs]	85
GMAP/UGG/MXLT/BV-163-C [SDU Sync to Audio Out Latency - AC8i: 32_2_gr, 16_2_gs]	85
GMAP/UGG/MXLT/BV-164-C [SDU Sync to Audio Out Latency - AC8i: 48_1_gr, 16_1_gs]	85
GMAP/UGG/MXLT/BV-165-C [SDU Sync to Audio Out Latency - AC8i: 48_2_gr, 16_2_gs]	85
GMAP/UGG/MXLT/BV-112-C [SDU Sync to Audio Out Latency - AC8i: 32_1_gr, 32_1_gs]	85
GMAP/UGG/MXLT/BV-113-C [SDU Sync to Audio Out Latency - AC8i: 32_2_gr, 32_2_gs]	85
GMAP/UGG/MXLT/BV-114-C [SDU Sync to Audio Out Latency - AC8i: 48_1_gr, 32_1_gs]	85
GMAP/UGG/MXLT/BV-115-C [SDU Sync to Audio Out Latency - AC8i: 48_2_gr, 32_2_gs]	85
GMAP/UGG/MXLT/BV-116-C [SDU Sync to Audio Out Latency - AC8i: 48_1_gr, 48_1_gs]	85
GMAP/UGG/MXLT/BV-117-C [SDU Sync to Audio Out Latency - AC8i: 48_2_gr, 48_2_gs]	85
GMAP/UGG/MXLT/BV-118-C [SDU Sync to Audio Out Latency - AC8i: 48_3_gr, 32_1_gs]	85
GMAP/UGG/MXLT/BV-119-C [SDU Sync to Audio Out Latency - AC8i: 48_4_gr, 32_2_gs]	85
GMAP/UGG/MXLT/BV-166-C [SDU Sync to Audio Out Latency - AC8ii: 32_1_gr, 16_1_gs]	85
GMAP/UGG/MXLT/BV-167-C [SDU Sync to Audio Out Latency - AC8ii: 32_2_gr, 16_2_gs]	85



GMAP/UGG/MXLT/BV-168-C [SDU Sync to Audio Out Latency - AC8ii: 48_1_gr, 16_1_gs].....	86
GMAP/UGG/MXLT/BV-169-C [SDU Sync to Audio Out Latency - AC8ii: 48_2_gr, 16_2_gs].....	86
GMAP/UGG/MXLT/BV-120-C [SDU Sync to Audio Out Latency - AC8ii: 32_1_gr, 32_1_gs].....	86
GMAP/UGG/MXLT/BV-121-C [SDU Sync to Audio Out Latency - AC8ii: 32_2_gr, 32_2_gs].....	86
GMAP/UGG/MXLT/BV-122-C [SDU Sync to Audio Out Latency - AC8ii: 48_1_gr, 32_1_gs].....	86
GMAP/UGG/MXLT/BV-123-C [SDU Sync to Audio Out Latency - AC8ii: 48_2_gr, 32_2_gs].....	86
GMAP/UGG/MXLT/BV-124-C [SDU Sync to Audio Out Latency - AC8ii: 48_1_gr, 48_1_gs].....	86
GMAP/UGG/MXLT/BV-125-C [SDU Sync to Audio Out Latency - AC8ii: 48_2_gr, 48_2_gs].....	86
GMAP/UGG/MXLT/BV-126-C [SDU Sync to Audio Out Latency - AC8ii: 48_3_gr, 32_1_gs].....	86
GMAP/UGG/MXLT/BV-127-C [SDU Sync to Audio Out Latency - AC8ii: 48_4_gr, 32_2_gs].....	86
GMAP/UGG/MXLT/BV-190-C [SDU Sync to Audio Out Latency - AC11i: 32_1_gr, 16_1_gs].....	86
GMAP/UGG/MXLT/BV-191-C [SDU Sync to Audio Out Latency - AC11i: 32_2_gr, 16_2_gs].....	86
GMAP/UGG/MXLT/BV-192-C [SDU Sync to Audio Out Latency - AC11i: 48_1_gr, 16_1_gs].....	86
GMAP/UGG/MXLT/BV-193-C [SDU Sync to Audio Out Latency - AC11i: 48_2_gr, 16_2_gs].....	86
GMAP/UGG/MXLT/BV-194-C [SDU Sync to Audio Out Latency - AC11i: 32_1_gr, 32_1_gs].....	86
GMAP/UGG/MXLT/BV-195-C [SDU Sync to Audio Out Latency - AC11i: 32_2_gr, 32_2_gs].....	87
GMAP/UGG/MXLT/BV-196-C [SDU Sync to Audio Out Latency - AC11i: 48_1_gr, 32_1_gs].....	87
GMAP/UGG/MXLT/BV-197-C [SDU Sync to Audio Out Latency - AC11i: 48_2_gr, 32_2_gs].....	87
GMAP/UGG/MXLT/BV-198-C [SDU Sync to Audio Out Latency - AC11i: 48_3_gr, 32_1_gs].....	87
GMAP/UGG/MXLT/BV-199-C [SDU Sync to Audio Out Latency - AC11i: 48_4_gr, 32_2_gs].....	87
GMAP/UGG/MXLT/BV-200-C [SDU Sync to Audio Out Latency - AC11ii: 32_1_gr, 16_1_gs].....	87
GMAP/UGG/MXLT/BV-201-C [SDU Sync to Audio Out Latency - AC11ii: 32_2_gr, 16_2_gs].....	87
GMAP/UGG/MXLT/BV-202-C [SDU Sync to Audio Out Latency - AC11ii: 48_1_gr, 16_1_gs].....	87
GMAP/UGG/MXLT/BV-203-C [SDU Sync to Audio Out Latency - AC11ii: 48_2_gr, 16_2_gs].....	87
GMAP/UGG/MXLT/BV-204-C [SDU Sync to Audio Out Latency - AC11ii: 32_1_gr, 32_1_gs].....	87
GMAP/UGG/MXLT/BV-205-C [SDU Sync to Audio Out Latency - AC11ii: 32_2_gr, 32_2_gs].....	87
GMAP/UGG/MXLT/BV-206-C [SDU Sync to Audio Out Latency - AC11ii: 48_1_gr, 32_1_gs].....	87
GMAP/UGG/MXLT/BV-207-C [SDU Sync to Audio Out Latency - AC11ii: 48_2_gr, 32_2_gs].....	87
GMAP/UGG/MXLT/BV-208-C [SDU Sync to Audio Out Latency - AC11ii: 48_3_gr, 32_1_gs].....	87
GMAP/UGG/MXLT/BV-209-C [SDU Sync to Audio Out Latency - AC11ii: 48_4_gr, 32_2_gs].....	87
4.4.4 UGG Max Total Latency in both directions	88
GMAP/UGG/MXLT/BV-220-C [UGG Combined Latencies - AC3: 32_1_gr, 16_1_gs]	89
GMAP/UGG/MXLT/BV-221-C [UGG Combined Latencies - AC3: 32_2_gr, 16_2_gs]	89
GMAP/UGG/MXLT/BV-222-C [UGG Combined Latencies - AC3: 48_1_gr, 16_1_gs]	89
GMAP/UGG/MXLT/BV-223-C [UGG Combined Latencies - AC3: 48_2_gr, 16_2_gs]	89
GMAP/UGG/MXLT/BV-224-C [UGG Combined Latencies - AC3: 32_1_gr, 32_1_gs]	89
GMAP/UGG/MXLT/BV-225-C [UGG Combined Latencies - AC3: 32_2_gr, 32_2_gs]	89
GMAP/UGG/MXLT/BV-226-C [UGG Combined Latencies - AC3: 48_1_gr, 32_1_gs]	89
GMAP/UGG/MXLT/BV-227-C [UGG Combined Latencies - AC3: 48_2_gr, 32_2_gs]	89
GMAP/UGG/MXLT/BV-228-C [UGG Combined Latencies - AC3: 48_1_gr, 48_1_gs]	89
GMAP/UGG/MXLT/BV-229-C [UGG Combined Latencies - AC3: 48_2_gr, 48_2_gs]	89
GMAP/UGG/MXLT/BV-230-C [UGG Combined Latencies - AC3: 48_3_gr, 32_1_gs]	89
GMAP/UGG/MXLT/BV-231-C [UGG Combined Latencies - AC3: 48_4_gr, 32_2_gs]	89
GMAP/UGG/MXLT/BV-232-C [UGG Combined Latencies - AC3: 48_3_gr, 48_1_gs]	89
GMAP/UGG/MXLT/BV-233-C [UGG Combined Latencies - AC3: 48_4_gr, 48_2_gs]	89
GMAP/UGG/MXLT/BV-234-C [UGG Combined Latencies - AC5: 32_1_gr, 16_1_gs]	89
GMAP/UGG/MXLT/BV-235-C [UGG Combined Latencies - AC5: 32_2_gr, 16_2_gs]	90
GMAP/UGG/MXLT/BV-236-C [UGG Combined Latencies - AC5: 48_1_gr, 16_1_gs]	90
GMAP/UGG/MXLT/BV-237-C [UGG Combined Latencies - AC5: 48_2_gr, 16_2_gs]	90
GMAP/UGG/MXLT/BV-238-C [UGG Combined Latencies - AC5: 32_1_gr, 32_1_gs]	90
GMAP/UGG/MXLT/BV-239-C [UGG Combined Latencies - AC5: 32_2_gr, 32_2_gs]	90
GMAP/UGG/MXLT/BV-240-C [UGG Combined Latencies - AC5: 48_1_gr, 32_1_gs]	90
GMAP/UGG/MXLT/BV-241-C [UGG Combined Latencies - AC5: 48_2_gr, 32_2_gs]	90
GMAP/UGG/MXLT/BV-242-C [UGG Combined Latencies - AC5: 48_1_gr, 48_1_gs]	90
GMAP/UGG/MXLT/BV-243-C [UGG Combined Latencies - AC5: 48_2_gr, 48_2_gs]	90
GMAP/UGG/MXLT/BV-244-C [UGG Combined Latencies - AC5: 48_3_gr, 32_1_gs]	90

GMAP/UGG/MXLT/BV-245-C [UGG Combined Latencies - AC5: 48_4_gr, 32_2_gs]	90
GMAP/UGG/MXLT/BV-246-C [UGG Combined Latencies - AC7ii: 32_1_gr, 16_1_gs]	90
GMAP/UGG/MXLT/BV-247-C [UGG Combined Latencies - AC7ii: 32_2_gr, 16_2_gs]	90
GMAP/UGG/MXLT/BV-248-C [UGG Combined Latencies - AC7ii: 48_1_gr, 16_1_gs]	90
GMAP/UGG/MXLT/BV-249-C [UGG Combined Latencies - AC7ii: 48_2_gr, 16_2_gs]	90
GMAP/UGG/MXLT/BV-250-C [UGG Combined Latencies - AC7ii: 32_1_gr, 32_1_gs]	91
GMAP/UGG/MXLT/BV-251-C [UGG Combined Latencies - AC7ii: 32_2_gr, 32_2_gs]	91
GMAP/UGG/MXLT/BV-252-C [UGG Combined Latencies - AC7ii: 48_1_gr, 32_1_gs]	91
GMAP/UGG/MXLT/BV-253-C [UGG Combined Latencies - AC7ii: 48_2_gr, 32_2_gs]	91
GMAP/UGG/MXLT/BV-254-C [UGG Combined Latencies - AC7ii: 48_1_gr, 48_1_gs]	91
GMAP/UGG/MXLT/BV-255-C [UGG Combined Latencies - AC7ii: 48_2_gr, 48_2_gs]	91
GMAP/UGG/MXLT/BV-256-C [UGG Combined Latencies - AC7ii: 48_3_gr, 32_1_gs]	91
GMAP/UGG/MXLT/BV-257-C [UGG Combined Latencies - AC7ii: 48_4_gr, 32_2_gs]	91
GMAP/UGG/MXLT/BV-258-C [UGG Combined Latencies - AC7ii: 48_3_gr, 48_1_gs]	91
GMAP/UGG/MXLT/BV-259-C [UGG Combined Latencies - AC7ii: 48_4_gr, 48_2_gs]	91
GMAP/UGG/MXLT/BV-260-C [UGG Combined Latencies - AC8i: 32_1_gr, 16_1_gs]	91
GMAP/UGG/MXLT/BV-261-C [UGG Combined Latencies - AC8i: 32_2_gr, 16_2_gs]	91
GMAP/UGG/MXLT/BV-262-C [UGG Combined Latencies - AC8i: 48_1_gr, 16_1_gs]	91
GMAP/UGG/MXLT/BV-263-C [UGG Combined Latencies - AC8i: 48_2_gr, 16_2_gs]	91
GMAP/UGG/MXLT/BV-264-C [UGG Combined Latencies - AC8i: 32_1_gr, 32_1_gs]	92
GMAP/UGG/MXLT/BV-265-C [UGG Combined Latencies - AC8i: 32_2_gr, 32_2_gs]	92
GMAP/UGG/MXLT/BV-266-C [UGG Combined Latencies - AC8i: 48_1_gr, 32_1_gs]	92
GMAP/UGG/MXLT/BV-267-C [UGG Combined Latencies - AC8i: 48_2_gr, 32_2_gs]	92
GMAP/UGG/MXLT/BV-268-C [UGG Combined Latencies - AC8i: 48_1_gr, 48_1_gs]	92
GMAP/UGG/MXLT/BV-269-C [UGG Combined Latencies - AC8i: 48_2_gr, 48_2_gs]	92
GMAP/UGG/MXLT/BV-270-C [UGG Combined Latencies - AC8i: 48_3_gr, 32_1_gs]	92
GMAP/UGG/MXLT/BV-271-C [UGG Combined Latencies - AC8i: 48_4_gr, 32_2_gs]	92
GMAP/UGG/MXLT/BV-272-C [UGG Combined Latencies - AC8ii: 32_1_gr, 16_1_gs]	92
GMAP/UGG/MXLT/BV-273-C [UGG Combined Latencies - AC8ii: 32_2_gr, 16_2_gs]	92
GMAP/UGG/MXLT/BV-274-C [UGG Combined Latencies - AC8ii: 48_1_gr, 16_1_gs]	92
GMAP/UGG/MXLT/BV-275-C [UGG Combined Latencies - AC8ii: 48_2_gr, 16_2_gs]	92
GMAP/UGG/MXLT/BV-276-C [UGG Combined Latencies - AC8ii: 32_1_gr, 32_1_gs]	92
GMAP/UGG/MXLT/BV-277-C [UGG Combined Latencies - AC8ii: 32_2_gr, 32_2_gs]	92
GMAP/UGG/MXLT/BV-278-C [UGG Combined Latencies - AC8ii: 48_1_gr, 32_1_gs]	93
GMAP/UGG/MXLT/BV-279-C [UGG Combined Latencies - AC8ii: 48_2_gr, 32_2_gs]	93
GMAP/UGG/MXLT/BV-280-C [UGG Combined Latencies - AC8ii: 48_1_gr, 48_1_gs]	93
GMAP/UGG/MXLT/BV-281-C [UGG Combined Latencies - AC8ii: 48_2_gr, 48_2_gs]	93
GMAP/UGG/MXLT/BV-282-C [UGG Combined Latencies - AC8ii: 48_3_gr, 32_1_gs]	93
GMAP/UGG/MXLT/BV-283-C [UGG Combined Latencies - AC8ii: 48_4_gr, 32_2_gs]	93
GMAP/UGG/MXLT/BV-284-C [UGG Combined Latencies - AC11i: 32_1_gr, 16_1_gs]	93
GMAP/UGG/MXLT/BV-285-C [UGG Combined Latencies - AC11i: 32_2_gr, 16_2_gs]	93
GMAP/UGG/MXLT/BV-286-C [UGG Combined Latencies - AC11i: 48_1_gr, 16_1_gs]	93
GMAP/UGG/MXLT/BV-287-C [UGG Combined Latencies - AC11i: 48_2_gr, 16_2_gs]	93
GMAP/UGG/MXLT/BV-288-C [UGG Combined Latencies - AC11i: 32_1_gr, 32_1_gs]	93
GMAP/UGG/MXLT/BV-289-C [UGG Combined Latencies - AC11i: 32_2_gr, 32_2_gs]	93
GMAP/UGG/MXLT/BV-290-C [UGG Combined Latencies - AC11i: 48_1_gr, 32_1_gs]	93
GMAP/UGG/MXLT/BV-291-C [UGG Combined Latencies - AC11i: 48_2_gr, 32_2_gs]	93
GMAP/UGG/MXLT/BV-292-C [UGG Combined Latencies - AC11i: 48_3_gr, 32_1_gs]	93
GMAP/UGG/MXLT/BV-293-C [UGG Combined Latencies - AC11i: 48_4_gr, 32_2_gs]	94
GMAP/UGG/MXLT/BV-294-C [UGG Combined Latencies - AC11ii: 32_1_gr, 16_1_gs]	94
GMAP/UGG/MXLT/BV-295-C [UGG Combined Latencies - AC11ii: 32_2_gr, 16_2_gs]	94
GMAP/UGG/MXLT/BV-296-C [UGG Combined Latencies - AC11ii: 48_1_gr, 16_1_gs]	94
GMAP/UGG/MXLT/BV-297-C [UGG Combined Latencies - AC11ii: 48_2_gr, 16_2_gs]	94
GMAP/UGG/MXLT/BV-298-C [UGG Combined Latencies - AC11ii: 32_1_gr, 32_1_gs]	94
GMAP/UGG/MXLT/BV-299-C [UGG Combined Latencies - AC11ii: 32_2_gr, 32_2_gs]	94
GMAP/UGG/MXLT/BV-300-C [UGG Combined Latencies - AC11ii: 48_1_gr, 32_1_gs]	94

GMAP/UGG/MXLT/BV-301-C [UGG Combined Latencies - AC11ii: 48_2_gr, 32_2_gs].....	94
GMAP/UGG/MXLT/BV-302-C [UGG Combined Latencies - AC11ii: 48_3_gr, 32_1_gs].....	94
GMAP/UGG/MXLT/BV-303-C [UGG Combined Latencies - AC11ii: 48_4_gr, 32_2_gs].....	94
4.5 Audio output synchronization.....	95
4.5.1 Audio output synchronization between two UGT devices	95
GMAP/UGT/SYNC/BV-16-C [Two UGTs Sync - AC6ii: 48_1_gr]	96
GMAP/UGT/SYNC/BV-17-C [Two UGTs Sync - AC6ii: 48_2_gr]	96
GMAP/UGT/SYNC/BV-07-C [Two UGTs Sync - AC6ii: 48_3_gr]	96
GMAP/UGT/SYNC/BV-08-C [Two UGTs Sync - AC6ii: 48_4_gr]	96
GMAP/UGT/SYNC/BV-01-C [Two UGTs Sync - AC8ii: 48_1_gr, 32_1_gs].....	96
GMAP/UGT/SYNC/BV-02-C [Two UGTs Sync - AC8ii: 48_2_gr, 32_2_gs].....	96
GMAP/UGT/SYNC/BV-20-C [Two UGTs Sync - AC8ii: 48_1_gr, 48_1_gs].....	96
GMAP/UGT/SYNC/BV-21-C [Two UGTs Sync - AC8ii: 48_2_gr, 48_2_gs].....	96
GMAP/UGT/SYNC/BV-22-C [Two UGTs Sync - AC8ii: 48_3_gr, 32_1_gs].....	96
GMAP/UGT/SYNC/BV-23-C [Two UGTs Sync - AC8ii: 48_4_gr, 32_2_gs].....	96
GMAP/UGT/SYNC/BV-03-C [Two UGTs Sync - AC11ii: 48_1_gr, 32_1_gs].....	96
GMAP/UGT/SYNC/BV-04-C [Two UGTs Sync - AC11ii: 48_2_gr, 32_2_gs].....	96
GMAP/UGT/SYNC/BV-24-C [Two UGTs Sync - AC11ii: 48_3_gr, 32_1_gs].....	96
GMAP/UGT/SYNC/BV-25-C [Two UGTs Sync - AC11ii: 48_4_gr, 32_2_gs].....	96
4.5.2 Audio output synchronization between two BGR devices	97
GMAP/BGR/SYNC/BV-03-C [Two BGRs Sync - AC13: 48_1_g].....	98
GMAP/BGR/SYNC/BV-04-C [Two BGRs Sync - AC13: 48_2_g].....	98
GMAP/BGR/SYNC/BV-01-C [Two BGRs Sync - AC13: 48_3_g].....	98
GMAP/BGR/SYNC/BV-02-C [Two BGRs Sync - AC13: 48_4_g].....	98
4.5.3 Audio output synchronization between two Audio Outs from a single UGT	99
GMAP/UGT/SYNC/BV-10-C [UGT Audio Outs Sync - AC5: 48_1_gr, 32_1_gs].....	100
GMAP/UGT/SYNC/BV-11-C [UGT Audio Outs Sync - AC5: 48_2_gr, 32_2_gs].....	100
GMAP/UGT/SYNC/BV-05-C [UGT Audio Outs Sync - AC5: 48_1_gr, 48_1_gs].....	100
GMAP/UGT/SYNC/BV-06-C [UGT Audio Outs Sync - AC5: 48_2_gr, 48_2_gs].....	100
GMAP/UGT/SYNC/BV-26-C [UGT Audio Outs Sync - AC5: 48_3_gr, 32_1_gs].....	100
GMAP/UGT/SYNC/BV-27-C [UGT Audio Outs Sync - AC5: 48_4_gr, 32_2_gs].....	100
GMAP/UGT/SYNC/BV-18-C [UGT Audio Outs Sync - AC6i: 48_1_gr].....	100
GMAP/UGT/SYNC/BV-19-C [UGT Audio Outs Sync - AC6i: 48_2_gr].....	100
GMAP/UGT/SYNC/BV-28-C [UGT Audio Outs Sync - AC6i: 48_3_gr].....	100
GMAP/UGT/SYNC/BV-29-C [UGT Audio Outs Sync - AC6i: 48_4_gr].....	100
GMAP/UGT/SYNC/BV-12-C [UGT Audio Outs Sync - AC8i: 48_1_gr, 32_1_gs].....	100
GMAP/UGT/SYNC/BV-13-C [UGT Audio Outs Sync - AC8i: 48_2_gr, 32_2_gs].....	100
GMAP/UGT/SYNC/BV-30-C [UGT Audio Outs Sync - AC8i: 48_1_gr, 48_1_gs].....	100
GMAP/UGT/SYNC/BV-31-C [UGT Audio Outs Sync - AC8i: 48_2_gr, 48_2_gs].....	100
GMAP/UGT/SYNC/BV-32-C [UGT Audio Outs Sync - AC8i: 48_3_gr, 32_1_gs].....	100
GMAP/UGT/SYNC/BV-33-C [UGT Audio Outs Sync - AC8i: 48_4_gr, 32_2_gs].....	100
GMAP/UGT/SYNC/BV-14-C [UGT Audio Outs Sync - AC11i: 48_1_gr, 32_1_gs].....	100
GMAP/UGT/SYNC/BV-15-C [UGT Audio Outs Sync - AC11i: 48_2_gr, 32_2_gs].....	101
GMAP/UGT/SYNC/BV-34-C [UGT Audio Outs Sync - AC11i: 48_3_gr, 32_1_gs].....	101
GMAP/UGT/SYNC/BV-35-C [UGT Audio Outs Sync - AC11i: 48_4_gr, 32_2_gs].....	101
4.5.4 Audio output synchronization between two Audio Outs from a single BGR	102
GMAP/BGR/SYNC/BV-07-C [BGR Audio Outs Sync - AC13: 48_1_g].....	103
GMAP/BGR/SYNC/BV-08-C [BGR Audio Outs Sync - AC13: 48_2_g].....	103
GMAP/BGR/SYNC/BV-05-C [BGR Audio Outs Sync - AC13: 48_3_g].....	103
GMAP/BGR/SYNC/BV-06-C [BGR Audio Outs Sync - AC13: 48_4_g].....	103
GMAP/BGR/SYNC/BV-09-C [BGR Audio Outs Sync - AC14: 48_1_g].....	103
GMAP/BGR/SYNC/BV-10-C [BGR Audio Outs Sync - AC14: 48_2_g].....	103
GMAP/BGR/SYNC/BV-11-C [BGR Audio Outs Sync - AC14: 48_3_g].....	103
GMAP/BGR/SYNC/BV-12-C [BGR Audio Outs Sync - AC14: 48_4_g].....	103
4.6 GMA Client and Server	105
4.6.1 GMA Client	105



GMAP/CL/CGGIT/SER/BV-01-C [GMAS Service Discovery]	105
GMAP/CL/CGGIT/CHA/BV-01-C [GMAP Role Read Characteristic, Client]	105
GMAP/CL/CGGIT/CHA/BV-03-C [UGG Features Read Characteristic, Client]	105
GMAP/CL/CGGIT/CHA/BV-02-C [UGT Features Read Characteristic, Client]	105
GMAP/CL/CGGIT/CHA/BV-04-C [BGS Features Read Characteristic, Client]	105
GMAP/CL/CGGIT/CHA/BV-05-C [BGR Features Read Characteristic, Client]	105
GMAP/CL/GMAS/BI-01-C [Client Ignores RFU Bits in GMAP Role Characteristic]	106
GMAP/CL/GMAS/BI-03-C [Client Ignores RFU Bits in UGG Features Characteristic]	106
GMAP/CL/GMAS/BI-02-C [Client Ignores RFU Bit in UGT Features Characteristic]	107
GMAP/CL/GMAS/BI-04-C [Client Ignores RFU Bits in BGS Features Characteristic]	107
GMAP/CL/GMAS/BI-05-C [Client Ignores RFU Bits in BGR Features Characteristic]	108
4.6.2 GMA Server	109
GMAP/SR/SGGIT/SER/BV-01-C [Service GGIT - GMAS]	109
GMAP/SR/SGGIT/CHA/BV-01-C [Characteristic GGIT - GMAP Role]	109
GMAP/SR/SGGIT/CHA/BV-03-C [Characteristic GGIT - UGG Features]	109
GMAP/SR/SGGIT/CHA/BV-02-C [Characteristic GGIT - UGT Features]	109
GMAP/SR/SGGIT/CHA/BV-04-C [Characteristic GGIT - BGS Features]	109
GMAP/SR/SGGIT/CHA/BV-05-C [Characteristic GGIT - BGR Features]	109
GMAP/SR/SGGIT/SDP/BV-01-C [SDP Record]	109
GMAP/UGG/GRC/BV-01-C [UGG Characteristic over LE]	110
GMAP/UGT/GRC/BV-01-C [UGT Characteristic over LE]	110
GMAP/BGS/GRC/BV-01-C [BGS Characteristic over LE]	110
GMAP/BGR/GRC/BV-01-C [BGR Characteristic over LE]	110
GMAP/UGG/GRC/BV-02-C [UGG Characteristic over BR/EDR]	110
GMAP/UGT/GRC/BV-02-C [UGT Characteristic over BR/EDR]	110
GMAP/BGS/GRC/BV-02-C [BGS Characteristic over BR/EDR]	110
GMAP/BGR/GRC/BV-02-C [BGR Characteristic over BR/EDR]	110
GMAP/UGG/GRC/BV-03-C [UGG Multiplex feature support, over LE]	111
GMAP/UGG/GRC/BV-04-C [UGG 96 kbps Source feature support, over LE]	111
GMAP/UGG/GRC/BV-05-C [UGG Multisink feature support, over LE]	111
GMAP/UGG/GRC/BV-06-C [UGG Multiplex feature support, over BR/EDR]	111
GMAP/UGG/GRC/BV-07-C [UGG 96 kbps Source feature support, over BR/EDR]	111
GMAP/UGG/GRC/BV-08-C [UGG Multisink feature support, over BR/EDR]	111
GMAP/UGT/GRC/BV-03-C [UGT Source feature support, over LE]	112
GMAP/UGT/GRC/BV-04-C [UGT 80 kbps Source feature support, over LE]	112
GMAP/UGT/GRC/BV-05-C [UGT Sink feature support, over LE]	112
GMAP/UGT/GRC/BV-09-C [UGT 64 kbps Sink feature support, over LE]	112
GMAP/UGT/GRC/BV-10-C [UGT Multiplex feature support, over LE]	112
GMAP/UGT/GRC/BV-11-C [UGT Multisink feature support, over LE]	112
GMAP/UGT/GRC/BV-12-C [UGT Multisource feature support, over LE]	112
GMAP/UGT/GRC/BV-06-C [UGT Source feature support, over BR/EDR]	112
GMAP/UGT/GRC/BV-07-C [UGT 80 kbps Source feature support, over BR/EDR]	112
GMAP/UGT/GRC/BV-08-C [UGT Sink feature support, over BR/EDR]	112
GMAP/UGT/GRC/BV-13-C [UGT 64 kbps Sink feature support, over BR/EDR]	112
GMAP/UGT/GRC/BV-14-C [UGT Multiplex feature support, over BR/EDR]	112
GMAP/UGT/GRC/BV-15-C [UGT Multisink feature support, over BR/EDR]	112
GMAP/UGT/GRC/BV-16-C [UGT Multisource feature support, over BR/EDR]	112
GMAP/BGS/GRC/BV-03-C [BGS 96 kbps Source feature support, over LE]	113
GMAP/BGS/GRC/BV-04-C [BGS 96 kbps Source feature support, over BR/EDR]	113
GMAP/BGR/GRC/BV-03-C [BGR Multisink feature support, over LE]	114
GMAP/BGR/GRC/BV-04-C [BGR Multiplex feature support, over LE]	114
GMAP/BGR/GRC/BV-05-C [BGR Multisink feature support, over BR/EDR]	114
GMAP/BGR/GRC/BV-06-C [BGR Multiplex feature support, over BR/EDR]	114
4.7 Device discovery and connection establishment	115
4.7.1 Device discovery – Role characteristic	115
GMAP/UGG/DDI/BV-01-C [Discovery of UGG]	115

GMAP/UGT/DDI/BV-01-C [Discovery of UGT]	115
GMAP/BGS/DDI/BV-01-C [Discovery of BGS]	115
GMAP/BGR/DDI/BV-01-C [Discovery of BGR]	115
4.8 Audio Locations and Supported Audio Contexts	115
4.8.1 BGR Audio Location	115
GMAP/BGR/AL/BV-01-C [BGR Audio Location Front Left]	116
GMAP/BGR/AL/BV-02-C [BGR Audio Location Front Right]	116
GMAP/BGR/AL/BV-03-C [BGR Audio Location Front Right and Front Left]	116
GMAP/BGR/SAC/BV-01-C [BGR Includes Game Context Type]	116
4.9 Updating Metadata	117
GMAP/BGS/META/BV-01-C [BGS updates Audio Contexts]	117
GMAP/UGG/META/BV-01-C [UGG updates Source ASE metadata]	117
GMAP/UGG/META/BV-02-C [UGG updates Sink ASE metadata]	117
5 Test case mapping	119
6 Revision history and acknowledgments	148
Appendix A Examples of Member-defined latency test approaches	149
A.1 Injecting an audio test pattern	149

1 Scope

This Bluetooth document contains the Test Suite Structure (TSS) and test cases to test the implementation of the Bluetooth Gaming Audio Profile (GMAP) Specification with the objective to provide a high probability of air interface interoperability between the tested implementation and other manufacturers' Bluetooth devices.

2 References, definitions, and abbreviations

2.1 References

This document incorporates provisions from other publications by dated or undated reference. These references are cited at the appropriate places in the text, and the publications are listed hereinafter. Additional definitions and abbreviations can be found in [1], [2], [3], [4], and [5].

- [1] Bluetooth Core Specification, Version 5.2 or later
- [2] Test Strategy and Terminology Overview
- [3] Basic Audio Profile (BAP) Specification, Version 1.0.1
- [4] Common Audio Profile (CAP) Specification, Version 1.0
- [5] Gaming Audio Profile (GMAP) Specification, Version 1.0 or later
- [6] ICS Proforma for Gaming Audio Profile (GMAP)
- [7] Implementation eXtra Information for Test (IXIT) for GMAP
- [8] GATT Test Suite, GATT.TS
- [9] Characteristic and Descriptor descriptions are accessible via the [Bluetooth SIG Assigned Numbers](#)
- [10] Document Naming and Marking Document
- [11] Performance Characterization of the Low Complexity Communication Codec
- [12] CAP Test Suite, CAP.TS
- [13] Cross-Correlation Python Script package:
https://www.bluetooth.org/docman/handlers/DownloadDoc.ashx?doc_id=556669
- [14] Published Audio Capabilities Service (PACS) Specification, Version 1.0 or later
- [15] Gaming Audio Profile (GMAP) Specification, Version 1.0.1

2.2 Definitions

In this Bluetooth document, the definitions from [1], [2], [3], [4], and [5] apply.

Additional definitions are provided in [Table 2.1](#).

Term	Definition
Audio In to SDU Sync Latency	Latency from the time audio is input until the corresponding audio SDUs arrive at the SDU Synchronization Reference. Applies when audio flows either from the Initiator to the Acceptor(s) and/or when audio flows from the Acceptor(s) to the Initiator.
Audio Signal Generator	A source of raw audio that can generate an audio signal with the correct frequency and modulation characteristics to support max latency or audio synchronization testing.
Instrumentation Delay	A delay introduced by instrumenting an audio path to expose Audio In or Audio Out.
Latency Timer	Test instrumentation that can identify the latency between audio signals at the input and output of a test system.



Term	Definition
SDU Sync to Audio Out Latency	Latency from the time audio SDUs arrive at the SDU Synchronization Reference to the time audio is presented to the end user at Audio Out. Applies when audio flows from the Initiator to the Acceptor(s) and also when audio flows from the Acceptor(s) to the Initiator.

Table 2.1: Additional definitions

2.3 Acronyms and abbreviations

In this Bluetooth document, the definitions, acronyms, and abbreviations from [1], [2], [3], [4], and [5] apply.

3 Test Suite Structure (TSS)

3.1 Overview

The Gaming Audio Profile (GMAP) [5] requires underlying profiles and services, notably the Common Audio Profile (CAP) [4] and the Basic Audio Profile (BAP) [3]. BAP is responsible for Audio Stream Control, as seen in Figure 3.2. Those profiles and services are verified by their respective Test Suites.

Figure 3.1 presents an overview of GMAP and its relationship to CAP, Capture and Rendering Control, Audio Stream Transitions control, and Core components.

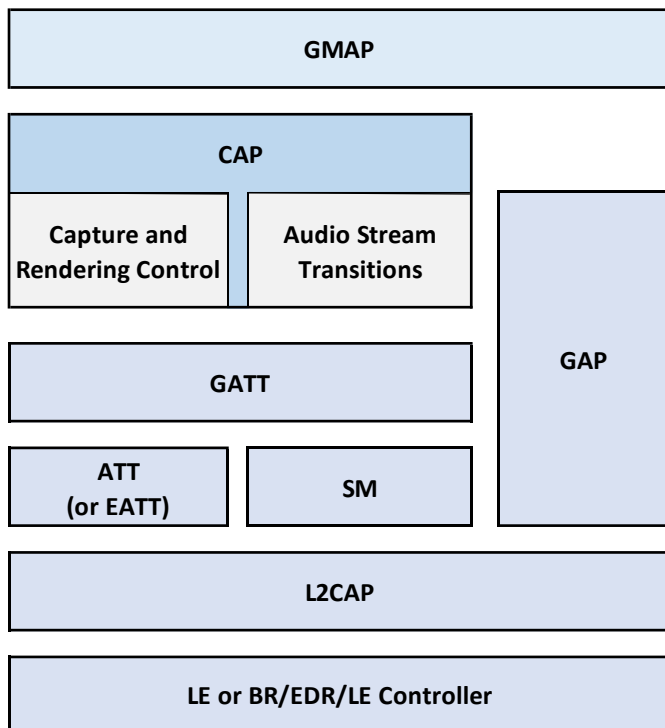

Figure 3.1: GMAP stack

Figure 3.2 provides a detailed breakdown of GMAP, CAP, and the underlying LE Audio profiles and services, with the services along the bottom row. The bottom two rows expand upon the Capture and Rendering Control, and Audio Stream Transitions control described in Figure 3.1, as well as additional LE Audio profiles and services specified in the ICS.

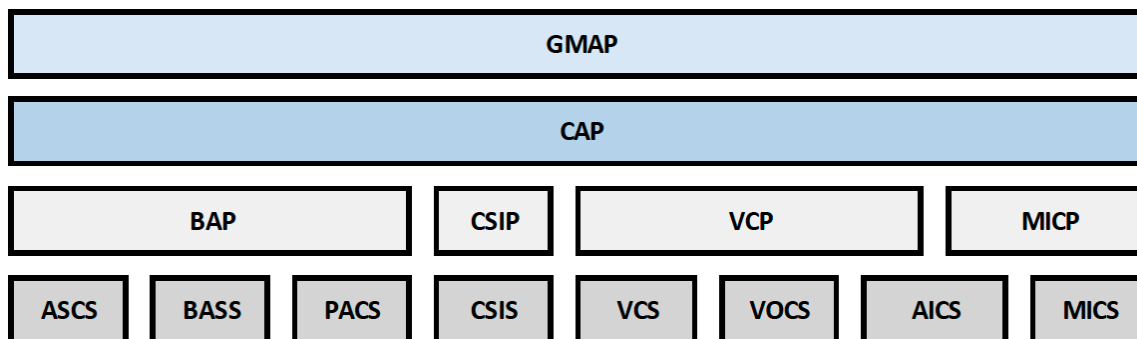

Figure 3.2: GMAP and LE Audio layers in detail

Figure 3.3 and Figure 3.4 describe the important relationship between the unicast and broadcast GMAP roles and their corresponding CAP and BAP roles. A Unicast Game Terminal (UGT) can either be a BAP Audio Sink, a BAP Audio Source, or both, to provide flexibility in configuring the gaming audio environment. A headphone device would be a BAP Audio Sink, and a gaming headset with its microphone enabled would be both a BAP Audio Source and a BAP Audio Sink.

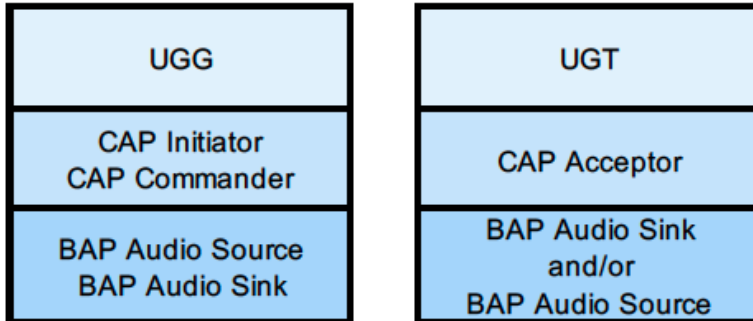

Figure 3.3: GMAP unicast roles and their relationship to CAP and BAP

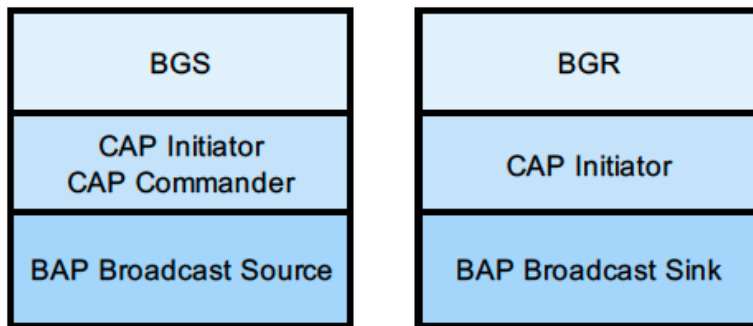

Figure 3.4: GMAP broadcast roles and their relationship to CAP and BAP

With its GMA Client and GMA Server roles, the Gaming Media Audio (GMA) Service is a service-discovery mechanism defined within GMAP (see Figure 3.5). This Test Suite includes the testing of the GMA Client and GMA Server.

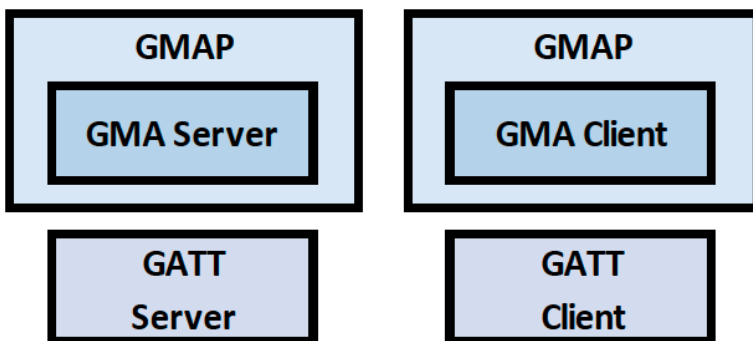

Figure 3.5: GMA Server and GMA Client

3.2 Test Strategy

The test objectives are to verify the functionality of the GMAP Specification within a Bluetooth Host and enable interoperability between Bluetooth Hosts on different devices. The testing approach covers mandatory and optional requirements in the specification and matches these to the support of the IUT as described in the ICS. Any defined test herein is applicable to the IUT if the ICS logical expression defined in the Test Case Mapping Table (TCMT) evaluates to true.

The test equipment provides an implementation of the Radio Controller and the parts of the Host needed to perform the test cases defined in this Test Suite. A Lower Tester acts as the IUT's peer device and interacts with the IUT over-the-air interface. The configuration, including the IUT, needs to implement similar capabilities to communicate with the test equipment. For some test cases, it is necessary to stimulate the IUT from an Upper Tester. In practice, this could be implemented as a special test interface, a Man Machine Interface (MMI), or another interface supported by the IUT.

For GMAP role dependencies defined in CAP, BAP, CSIP, MICP, and VCP, inter-layer dependencies (ILDs) in the ICS enable the appropriate testing associated with the referenced roles.

In some cases, it is necessary to specify two IUTs. Testing for multi-stream synchronization for two Acceptors, as described in Section 3.2.2.2, [Multi-stream synchronization for two Acceptors](#), explains how left and right Audio Outs are produced by separate IUTs, rather than by a single IUT.

The gaming audio Quality of Service (QoS) settings are tested in this GMAP Test Suite, as they have no equivalent to those in BAP.

The audio codec settings are identical to existing Audio Sink configurations in BAP. ILDs in the ICS enable the appropriate testing associated with the referenced configurations.

GMAP specifies specific Audio Configurations, gaming audio, and voice QoS settings. It is confirmed by testing in this Test Suite that such configurations are supported, including that the Audio Locations and Audio Channel Allocations are correctly handled. It is also confirmed that, for the supported configurations, the latency requirements specified in Section 3.6, Latency requirements, in [5] are also met.

It is confirmed by testing in this Test Suite that "Game" is provided as a Context Type in the Supported Audio Contexts characteristics and Available Audio Contexts characteristics.

Section 3.6, Latency requirements, in [5] specifies requirements to ensure low Total System Delay. The test strategy for testing these requirements is in Section 3.2.1, [Latency testing overview and procedures](#).

Section 3.7, Synchronization requirements, in [5] specifies requirements to ensure synchronization between two audio outputs. The test configurations to support this testing are described in Section 3.2.1.8, [Examples of additional latency test approaches](#)

One or more examples of additional techniques that can be employed to measure audio latency are described in [Appendix A](#).

Audio output synchronization overview and test configurations, while test methods to measure audio signal synchronization are described in Section 3.2.3, [Synchronization test methodologies](#).

This Test Suite contains Valid Behavior (BV) tests complemented with Invalid Behavior (BI) tests where required. The test coverage mirrored in the Test Suite Structure is the result of a process that started with catalogued specification requirements that were logically grouped and assessed for testability enabling coverage in defined test purposes.



3.2.1 Latency testing overview and procedures

Figure 3.6 describes a configuration with a Unicast Game Gateway (UGG) or Broadcast Game Sender (BGS) capturing left and right audio, or mono audio, and sending it to one or two Unicast Game Terminal (UGT) or Broadcast Game Receiver (BGR) devices. It identifies the two components that make up the Total System Delay: the “Audio In to SDU Sync Latency” and the “SDU Sync to Audio Out Latency”.

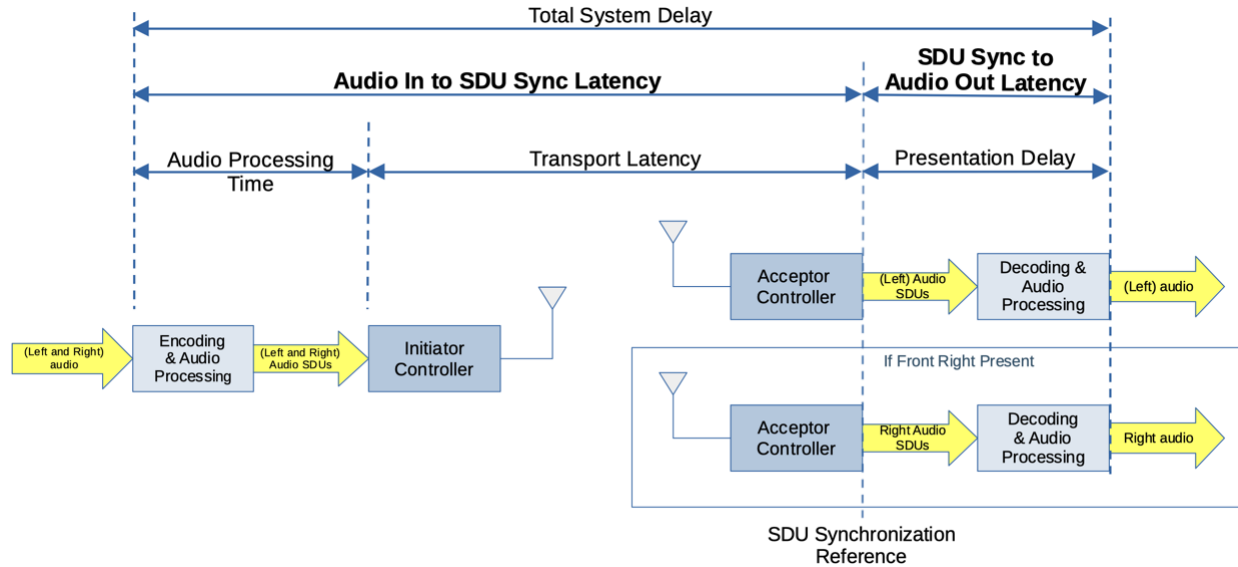

Figure 3.6: Generalized Initiator to Acceptor audio system delays

While Section 3.6, Latency requirements, in [5] specifies a maximum Total System Delay of 40 ms in the Initiator to Acceptor direction, GMAP devices are not tested as a system, so the individual latency contributions to the Total System Delay are tested.

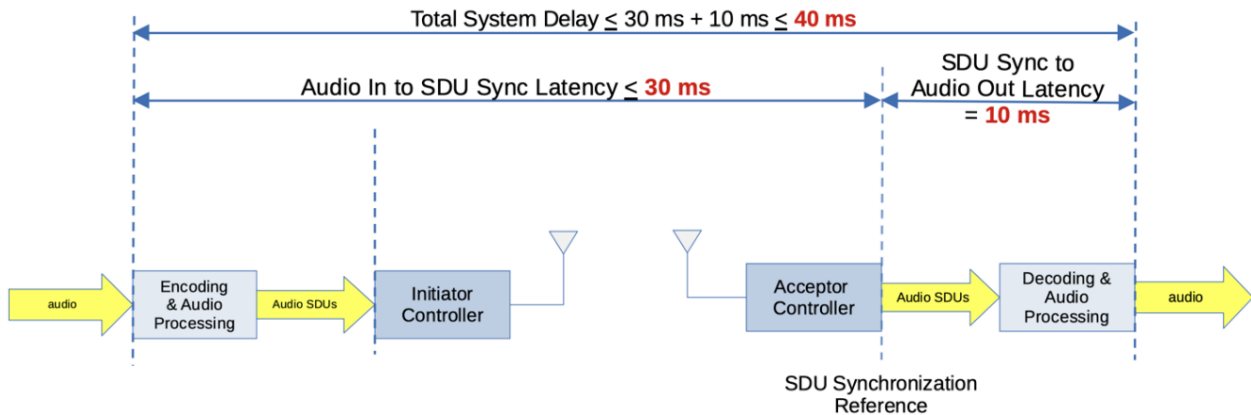

Figure 3.7: Breakdown of a 40 ms Total System Delay into the maximum 30 ms Audio In to SDU Sync Latency and the 10 ms SDU Sync to Audio Out Latency

Referring to Figure 3.7, the time from the input to the Encoding & Audio Processing to the SDU Synchronization Reference can be no greater than 30 ms. In this Test Suite, this latency is designated the “Audio In to SDU Sync Latency”. The time from the SDU Synchronization Reference to the audio output is equivalent to the Presentation Delay and is 10 ms. In this Test Suite, this latency is designated the “SDU Sync to Audio Out Latency”.

Section 5.5.2 of the TSTO [2] describes the audio reference signal to be used for testing audio latency. Frequencies outside of 1 kHz are permissible to the extent permitted in Section 3.7, Synchronization requirements, in [5].

The approach in the Initiator to Acceptor direction is addressed in more detail in Section 3.2.1.2, [Audio In to SDU Sync Latency test strategy, Initiator to Acceptor, IUT is Initiator](#), and Section 3.2.1.3, [SDU Sync to Audio Out Latency test strategy, Initiator to Acceptor, IUT is Acceptor](#).

The approach taken when measuring latency in the Acceptor to Initiator direction is nearly identical to that described so far, but with the directions flipped. As this direction is only valid for UGT and UGG devices, [Figure 3.8](#) describes the audio flow from the UGT to UGG direction.

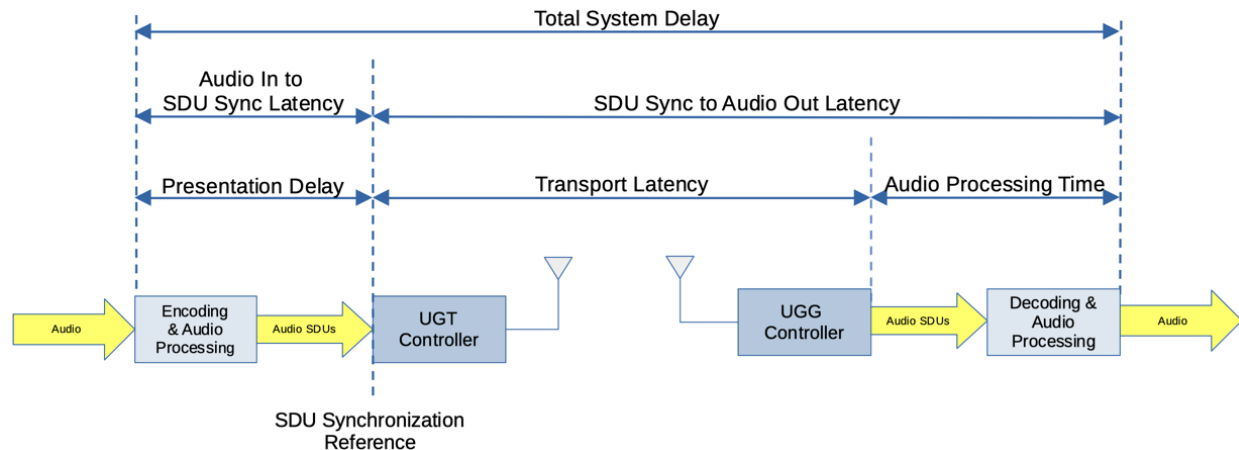

Figure 3.8: Generalized UGT to UGG audio system delays

Note that the SDU Synchronization Reference remains at the UGT. The Audio In to SDU Sync Latency is equivalent to the Presentation Delay. The SDU Sync to Audio Out Latency combines the Transport Latency and the Audio Processing Time at the UGG. (The Presentation Delay varies with Streaming Direction and Set Name per Table 3.14: QoS configuration support setting requirements for the UGG and UGT in [5].)

Section 3.6, Latency requirements, in [5] specifies a Total System Delay of 100 ms in the UGT to UGG direction. The Audio In to SDU Sync Latency is the Presentation Delay. The SDU Sync to Audio Out Latency can be no greater than 100 ms minus the Presentation Delay, which equals 40 ms.

The approach in the UGT to UGG direction is addressed in more detail in Section 3.2.1.4, [Audio In to SDU Sync Latency test strategy, UGT to UGG, IUT is UGT](#), and Section 3.2.1.5, [SDU Sync to Audio Out Latency test strategy, UGT to UGG, IUT is UGG](#).

For UGG IUT devices that cannot provide an external Audio In and/or Audio Out, either natively or using the instrumented approaches described in this section, Section 3.2.1.7, [Audio loopback for UGG IUTs without external Audio In and/or Audio Out](#), describes a means of testing the combined latency of the UGG in the UGT to UGG and the UGG to UGT audio directions.

3.2.1.1 Latency testing overview

An approach to measure the impact of the Initiator or Acceptor IUT on the Total System Delay is for a Latency Timer to compare Audio In or Audio Out with the SDU Synchronization Reference point as determined from the over-the-air PDUs.

[Figure 3.9](#) presents a reference describing the functional blocks of a test system for performing latency testing when the IUT is the Acceptor and audio is flowing in the Initiator to Acceptor direction. These functional blocks are used to describe various latency test configurations in the later sections. While a test system may be laid out with physical components in precisely the manner described, Section 3.2.1.1.1, [Alternative latency test system configurations](#), describes how these functional blocks may be combined in different test systems.

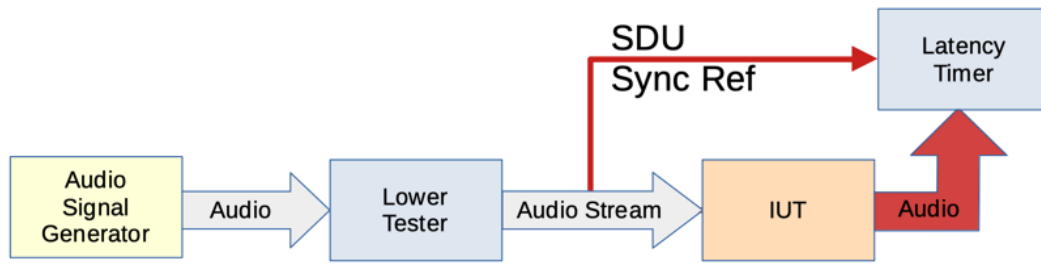

Figure 3.9: Latency testing with an Acceptor IUT, Initiator to Acceptor audio direction

Figure 3.9 describes a system using the SDU Synchronization Reference as monitored over the air by the Latency Timer. Figure 3.9 can also be used to describe audio flowing in the UGT to UGG direction with the IUT being the UGG.

The Audio Signal Generator produces an analog audio signal, which drives the Audio In input on the Lower Tester. The Lower Tester produces a unicast or broadcast Audio Stream, which is then received by the IUT. The Latency Timer monitors the over-the-air PDU traffic to identify when the SDU Synchronization Reference occurs. Finally, the audio output from the IUT is sent to the Latency Timer, which allows it to determine the SDU Sync to Audio Out Latency.

An Upper Tester to command the IUT is presumed, but not shown, in Figure 3.9 and later figures.

Note also that in Figure 3.9, and in later figures, SDU Synchronization Reference is shortened to “SDU Sync Ref” for brevity.

A +/- 10 μ s instrumentation tolerance is used for timing tolerances to account for measuring variability and tolerances in the Latency Timer.

3.2.1.1.1 Alternative latency test system configurations

Figure 3.9 describes the basic functional elements of a test system for performing latency testing as individual components of a test system. In practice, those functional elements may be combined in different ways.

Figure 3.10 presents a simplification of the test system configuration described in Figure 3.9. In this system, the Latency Timer itself provides the analog audio to the Lower Tester’s Audio In input. It measures the SDU Sync to Audio Out Latency when it determines the SDU Synchronization Reference and detects the audio at Audio Out.

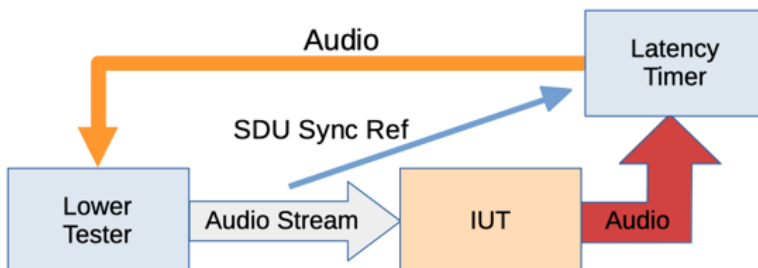

Figure 3.10: Latency testing with an Acceptor IUT, Initiator to Acceptor audio direction, Latency Timer provides audio

The approach presented in Figure 3.11 provides another possible simplification of the test system described in Figure 3.9. In this configuration, the Lower Tester contains an internal audio source, serving the purpose of the Audio Signal Generator.

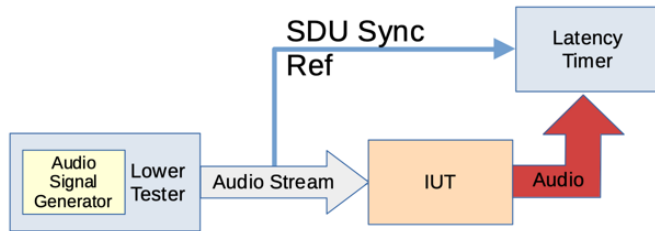

Figure 3.11: Latency testing with the Lower Tester producing its own audio

Figure 3.12 presents an even greater simplification to the test system where the Lower Tester incorporates the functionality of the Audio Signal Generator and the Latency Timer.

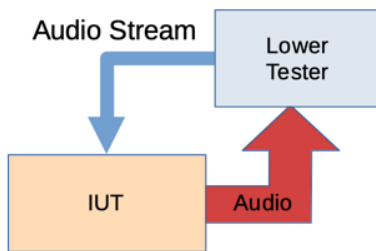

Figure 3.12: Latency testing with an IUT that sinks audio, Lower Tester acts as Latency Timer, Audio Stream is input

This configuration can be used to test an Acceptor IUT when audio is flowing in the Initiator to Acceptor direction, or to test the UGG when audio is flowing in the UGT to UGG direction.

Figure 3.13 presents a test system similar to Figure 3.12. In this configuration, the Lower Tester provides the analog audio and monitors the unicast or broadcast audio stream from the IUT. This configuration can be used to test an Initiator IUT when audio is flowing in the Initiator to Acceptor direction, or to test the UGT when audio is flowing in the UGT to UGG direction. The Lower Tester incorporates the functionality of the Audio Signal Generator and the Latency Timer.

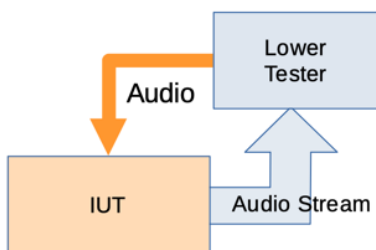

Figure 3.13: Latency testing with an IUT that sources audio, Lower Tester acts as Latency Timer, audio is input

3.2.1.2 Audio In to SDU Sync Latency test strategy, Initiator to Acceptor, IUT is Initiator

The Audio In to SDU Sync Latency for the Initiator IUT is determined by the Latency Timer. It takes the difference between the Audio In to the Initiator IUT and the SDU Synchronization Reference point determined from the over-the-air PDUs. This is demonstrated in [Figure 3.14](#).

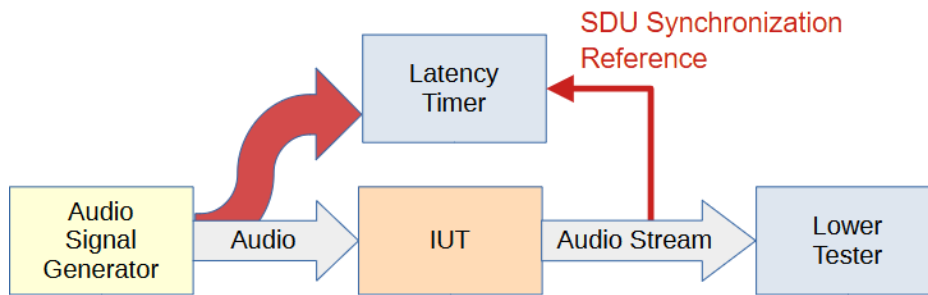

Figure 3.14: Measuring Audio In to SDU Sync Latency via SDU Synchronization Reference point, Initiator to Acceptor

When a UGG provides audio streams for two UGT devices, it is important to the test that the UGG supports both audio streams to demonstrate latency under such conditions. [Figure 3.15](#) describes a configuration that adds a second Lower Tester to receive the second audio stream. A second Lower Tester is not necessary for a BGS, since it will broadcast both streams regardless of whether a second Lower Tester is present.

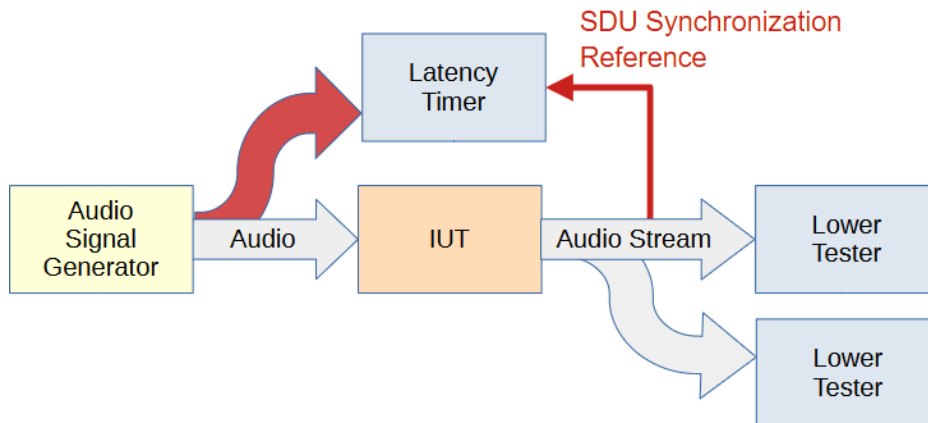

Figure 3.15: Measuring Audio In to SDU Sync Latency via SDU Synchronization Reference point, Initiator to Acceptor, with two Lower Testers

If Audio In is not readily available, then the techniques described in [Section 3.2.1.6.1, Instrumented Audio In feeds Encoding & Audio Processing](#), and [Section 3.2.1.6.2, Audio In is brought out by other means](#), may be employed.

3.2.1.3 SDU Sync to Audio Out Latency test strategy, Initiator to Acceptor, IUT is Acceptor

The SDU Sync to Audio Out Latency for the Acceptor IUT is determined by the Latency Timer. It takes the difference between the SDU Synchronization Reference point determined from the over-the-air PDUs and the Audio Out from the Acceptor IUT. This is demonstrated in [Figure 3.16](#).

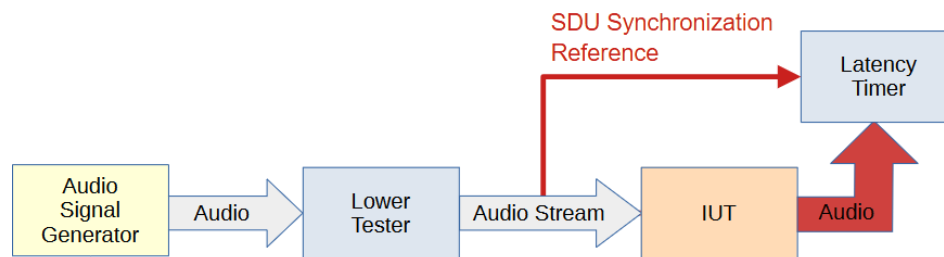

Figure 3.16: Measuring SDU Sync to Audio Out Latency via SDU Synchronization Reference point, Initiator to Acceptor

3.2.1.4 Audio In to SDU Sync Latency test strategy, UGT to UGG, IUT is UGT

The Audio In to SDU Sync Latency for the UGT IUT is determined by the Latency Timer. It takes the difference between the Audio In to the UGT IUT and the SDU Synchronization Reference point as determined from the over-the-air PDUs. This is demonstrated in [Figure 3.17](#).

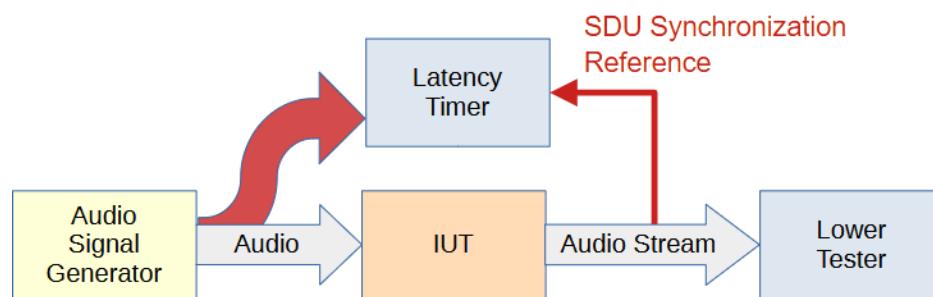

Figure 3.17: Measuring Audio In to SDU Sync Latency via SDU Synchronization Reference point, UGT to UGG

3.2.1.5 SDU Sync to Audio Out Latency test strategy, UGT to UGG, IUT is UGG

The SDU Sync to Audio Out Latency for the UGG IUT is determined by the Latency Timer. It takes the difference between the SDU Synchronization Reference point determined from the over-the-air PDUs and the Audio Out from the UGG IUT. This is demonstrated in [Figure 3.18](#).

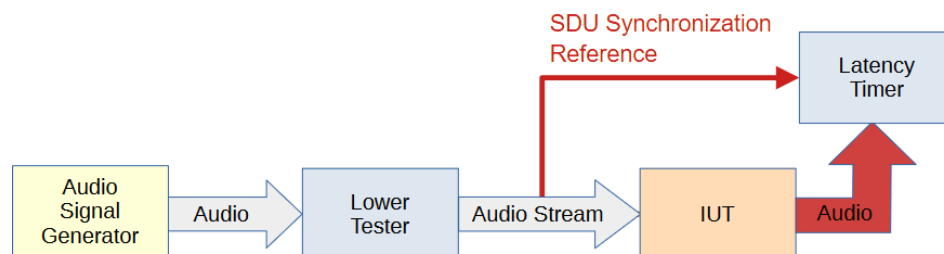

Figure 3.18: Measuring SDU Sync to Audio Out Latency via SDU Synchronization Reference point, UGT to UGG

Figure 3.19 demonstrates the scenario where the IUT is receiving audio from two UGT Lower Testers. For test purposes, this scenario is set up similarly to the single Lower Tester scenario; however, it demonstrates a critical ability of the IUT to continue to perform within the latency boundaries while receiving two independent audio streams.

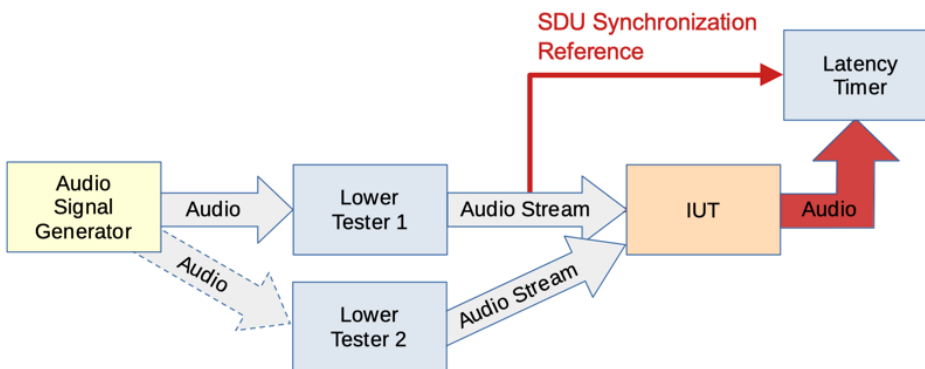

Figure 3.19: Measuring SDU Sync to Audio Out Latency via SDU Synchronization Reference point, UGT to UGG, with two Lower Testers

If Audio Out is not readily available, then the technique described in Section 3.2.1.6.3, [Audio Out is brought out at UGG](#), may be employed.

3.2.1.6 Instrumented Audio In and Audio Out

The source or destination of audio (Audio In and Audio Out) is not always directly accessible in an IUT. For example, a UGG may generate its game audio using a game engine local to the device, and there is no exposed Audio In that can be used to detect when the audio has entered the Encoding & Audio Processing function as identified in [Figure 3.6](#) and other figures.

Conversely, a UGG may send game chat audio received from a UGT over the internet to a gaming server, with no exposed Audio Out that can be accessed as it exits the Decoding & Audio Processing function as identified in [Figure 3.6](#) and other figures.

The following sections describe approaches that can be used with UGG devices, and in the case of Audio In, BGS devices. It allows the Audio In and/or Audio Out to be brought out through instrumented means. As this will generally add additional latency, IXIT values are provided to compensate for those latencies.

In the following diagrams, the components with a red outline represent components added to instrument the IUT to expose an Audio In or Audio Out signal, and also to flag the Measured Total System Delay with the added delay introduced by the instrumented Audio In or Audio Out.

3.2.1.6.1 Instrumented Audio In feeds Encoding & Audio Processing

Figure 3.20 describes an approach by which an external signal is instrumented to provide an audio signal that a UGG or BGS then processes.

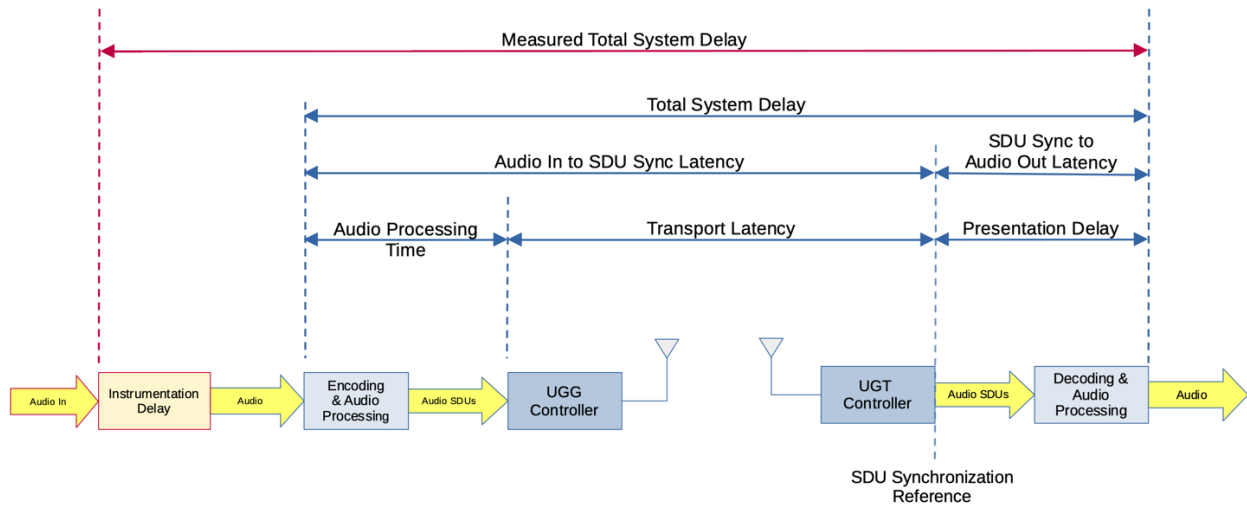

Figure 3.20: Instrumented Audio In feeds Encoding & Audio Processing

As the means required to capture the instrumented Audio In and feed it to the Encoding & Audio Processing function can take time, the TSPX_instrumented_audio_in_delay value in IXIT [7] is provided to inform the Latency Timer to remove this latency from the Measured Total System Delay. In this configuration, TSPX_instrumented_audio_in_delay is always a positive number. A value of zero indicates that the Audio In signal arrives at the same time as the internal signal or, more likely, that this technique is not employed in testing max latency.

3.2.1.6.2 Audio In is brought out by other means

Specific platforms may have mechanisms that lend themselves to other approaches, such as echoing the audio signal to an external interface, receiving an external start trigger, or generating an outgoing external trigger.

3.2.1.6.3 Audio Out is brought out at UGG

Figure 3.21 describes an approach by which the audio sent by a UGT and then output from the UGG from its Decoding & Audio Processing function is then instrumented to provide an external Audio Out signal.

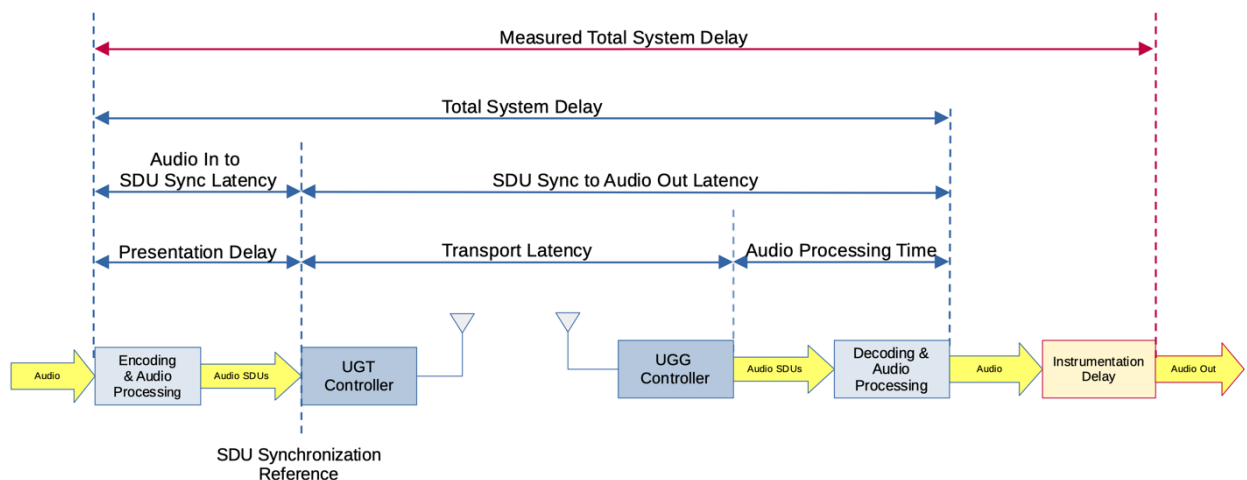

Figure 3.21: Audio Out is brought out at UGG

As the means required to capture the audio from the Decoding & Audio Processing function and provide it as an external Audio Out signal can take time, the TSPX_instrumented_audio_out_delay value in IXIT [7] is provided to inform the Latency Timer to remove this latency from the Measured Total System Delay. TSPX_instrumented_audio_out_delay is always a positive number. A value of zero indicates that the Audio Out signal arrives at the same time as the internal signal or, more likely, that this technique is not employed in testing max latency.

3.2.1.7 Audio loopback for UGG IUTs without external Audio In and/or Audio Out

For UGG IUT devices that cannot provide an external Audio In and/or Audio Out, either natively or using the instrumented approaches described in prior sections, this section describes a means of testing the combined latency of the UGG in the UGT to UGG and the UGG to UGT audio directions.

This approach captures the total latency introduced by the UGG when audio is sent from the UGT to the UGG and echoed back to the UGT by including an audio loopback mechanism internal to the IUT. Ideally, the audio loopback introduces no additional latency, though even slight latency might not fail the IUT using this approach. The configuration is shown in Figure 3.22 for an Audio Configuration with a single UGT Lower Tester. Diagrams describing audio loopback testing for Audio Configurations requiring two Lower Testers are given in Section 3.2.1.7.1, Audio loopback with two UGT Lower Testers. To simplify the diagram, a Latency Timer, Audio Signal Generator, and Upper Tester are assumed to be present but are not shown and are used in the same manner as described in previous sections.

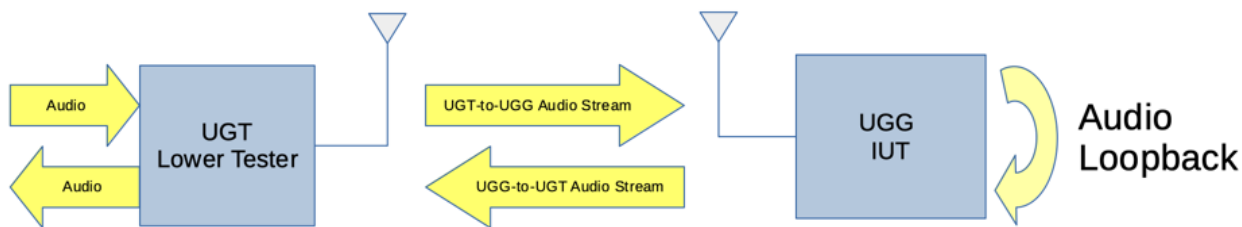

Figure 3.22: UGG audio loopback test configuration

The flow of audio as an MSC is given in Figure 3.23.

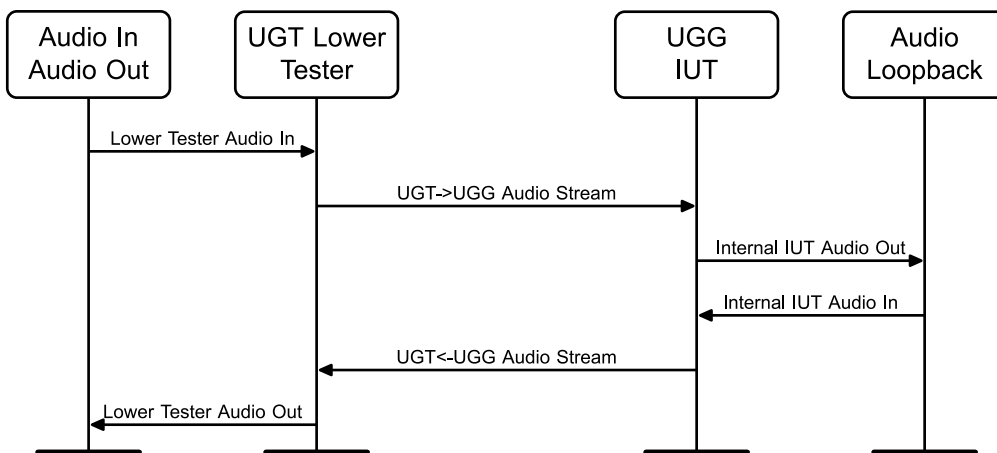

Figure 3.23: Audio Flow using audio loopback MSC

The total latency measured using this approach is the SDU Sync to Audio Out Latency plus the Audio In to SDU Sync Latency. As outlined in Section 3.6, Latency requirements, in [5], the latency budgets are 40 ms and 30 ms, respectively. Therefore, for this testing, SDU Sync to Audio Out Latency plus the Audio In to SDU Sync Latency may not exceed 70 ms.

There are essentially two approaches to measuring the overall UGG latency. Since the Presentation Delay is fixed for the UGT Lower Tester in both directions, the Total System Delay can be measured and the Presentations Delays subtracted to get the UGG latency, or the SDU Synchronization References can be determined from over-the-air PDUs, which is the more direct method.

3.2.1.7.1 Audio loopback with two UGT Lower Testers

Figure 3.24 describes the audio loopback test configuration for AC 11(ii), in which audio is sent in both directions between the two UGT Lower Testers and the UGG IUT. The Latency Timer may pick either UGT Lower Tester to measure latency, but the UGG IUT establishes and maintains the streams to both UGT Lower Testers to adequately exercise the UGG IUT. Both UGT Lower Testers send audio to the UGG IUT, and a dedicated audio loopback is provided for each UGT Lower Tester, such that the audio sent by the UGT Lower Tester is the audio it receives.

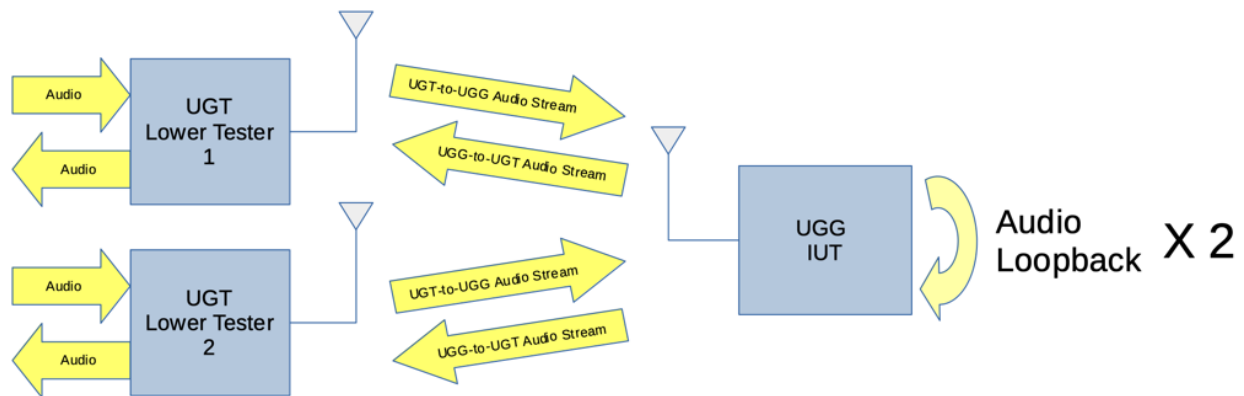

Figure 3.24: UGG Audio Loopback AC 11(ii) test configuration

Figure 3.25 describes the audio loopback test configuration for AC 8(ii). Audio is sent in both directions between UGT Lower Tester 1 and the UGG IUT. The UGG IUT sends audio to UGT Lower Tester 2 but does not receive audio from it. The Latency Timer measures latency on UGT Lower Tester 1. The UGG IUT sends audio to both UGT Lower Testers to adequately exercise the UGG IUT. The audio loopback sends the audio received from UGT Lower Tester 1 to both UGT Lower Testers.

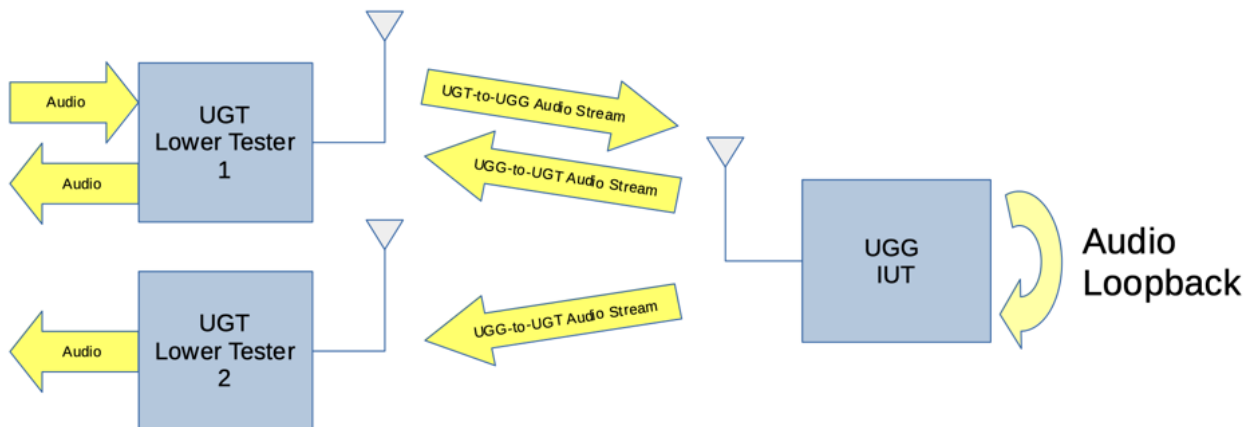

Figure 3.25: UGG Audio Loopback AC 8(ii) test configuration

Figure 3.26 describes the audio loopback test configuration for AC 7(ii), in which audio is sent from UGT Lower Tester 1 to the UGG IUT, and audio is sent to UGT Lower Tester 2 from the UGG IUT. The Latency Timer measures latency from UGT Lower Tester 1 to UGT Lower Tester 2. The audio loopback sends the audio received from UGT Lower Tester 1 to UGT Lower Tester 2.

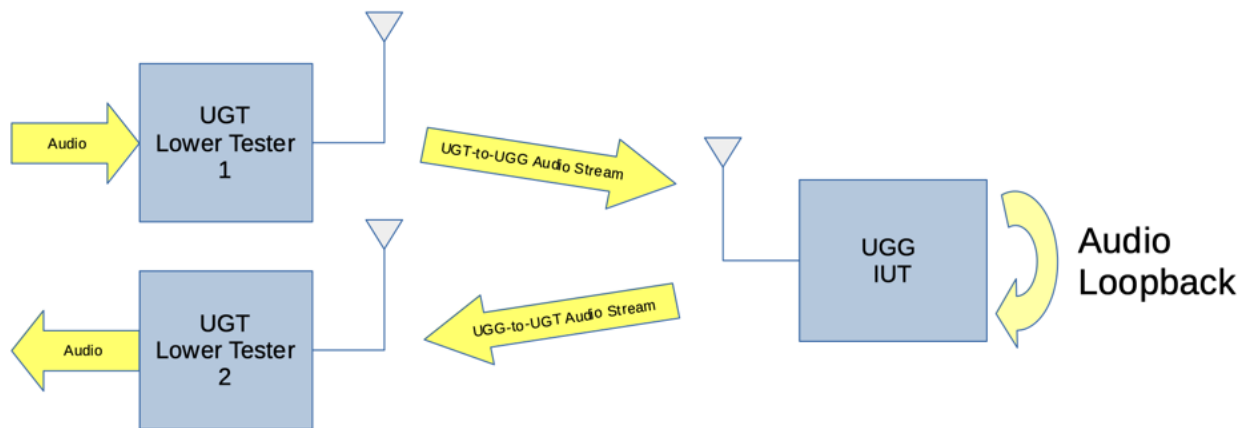

Figure 3.26: UGG Audio Loopback AC 7(ii) test configuration

3.2.1.8 Examples of additional latency test approaches

One or more examples of additional techniques that can be employed to measure audio latency are described in Appendix A.

3.2.2 Audio output synchronization overview and test configurations

Section 5.5.4 of [2] describes the audio output synchronization overview and test configurations.

3.2.2.1 Synchronization for devices with two Audio Outs

The Audio Configurations tested are described in Table 3.1, all of which describe a single UGG or BGS producing two channels configured for Front Left and Front Right, both received by a single UGT or BGR, respectively.

Test Configuration	Legend	BAP Configuration	GMAP IUT Roles
Unicast Unidirectional, multiplexed	<----->>	5	UGT
Unicast Unidirectional, two ASEs	-----> ----->	6(i)	UGT
Unicast Bidirectional, two ASEs	-----> <----->	8(i)	UGT
Unicast Bidirectional, sync in both directions	<-----> <----->	11(i)	UGT, UGG
Broadcast, two streams	⤵ ⤵	13	BGR

Table 3.1: Synchronization for one Acceptor receiving two Audio Streams Audio Configurations

3.2.2.2 Multi-stream synchronization for two Acceptors

The Audio Configurations tested are described in Table 3.2, all of which describe a single UGG or BGS producing two streams such that two Acceptors configured for left and right each connect or synchronize to their respective Front Left and Front Right audio streams, with the exception that in the BAP Configuration 14 case, both BGRs receive the same audio stream, but one chooses to produce the left channel on its Audio Out, while the other produces the right channel.



Test Configuration	Legend	BAP Configuration	GMAP IUT Roles
Unicast Unidirectional, two ASEs		6(ii)	UGT
Unicast Bidirectional, two ASEs		8(ii)	UGT
Unicast Bidirectional, sync in both directions		11(ii)	UGT, UGG
Broadcast, two streams		13	BGR

Table 3.2: Synchronization for two Acceptors Audio Configurations

3.2.3 Synchronization test methodologies

Synchronization test methodologies are described in Section 5.5.5 of [2].

3.2.3.1 Audio reference signal

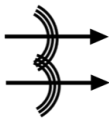
Section 5.5.2 of [2] describes the audio reference signal to be used for testing audio synchronization.

Frequencies outside of 1 kHz are permissible to the extent permitted in Section 3.7, Synchronization requirements, in [5].

3.2.3.2 Audio output measurement

Section 5.5.3 of [2] describes the audio output measurement.

3.3 Test groups

The following test groups have been defined:

- Low Latency Unicast Audio Streaming
- Low Latency Broadcast Audio Streaming
- Maximum latency
- Audio output synchronization
- Gaming Audio (GMA) Client and Server
- Device discovery
- Audio Locations
- Updating Metadata
- Supported Audio Contexts

4 Test cases (TC)

4.1 Introduction

4.1.1 Test case identification conventions

Test cases are assigned unique identifiers per the conventions in [2]. The convention used here is: **<spec abbreviation>/<IUT role>/<class>/<feat>/<func>/<subfunc>/<cap>/<xx>-<nn>-<y>**.

Additionally, testing of this specification includes tests from the GATT Test Suite [8] referred to as Generic GATT Integrated Tests (GGIT); when used, the GGIT tests are referred to through a TCID string using the following convention:

<spec abbreviation>/<IUT role>/<GGIT test group>/< GGIT class >/<xx>-<nn>-<y>.

Identifier Abbreviation	Spec Identifier <spec abbreviation>
GMAP	Gaming Audio Profile (GMAP)
Identifier Abbreviation	Role Identifier <IUT role>
BGR	Broadcast Game Receiver
BGS	Broadcast Game Sender
CL	GMA Client
SR	GMA Server
UGT	Unicast Game Terminal
UGG	Unicast Game Gateway
Identifier Abbreviation	Reference Identifier <GGIT test group>
CGGIT	Client Generic GATT Integrated Tests
SGGIT	Server Generic GATT Integrated Tests
Identifier Abbreviation	Reference Identifier <GGIT class>
CHA	Characteristic
SDP	SDP Record
SER	Service
Identifier Abbreviation	Features and Behaviors Identifier <feat>
AL	Audio Locations
DDI	Device Discovery and Connection Establishment
GMAS	Gaming Audio Service
GRC	GMAP role characteristic
META	Metadata update operations
MXLT	Maximum latency
LLB	Low Latency Broadcast Audio Streaming
LLU	Low Latency Unicast Audio Streaming
SAC	Supported Audio Contexts
SYNC	Audio Out synchronization

Table 4.1: GMAP TC feature naming conventions

4.1.2 Conformance

When conformance is claimed for a particular specification, all capabilities are to be supported in the specified manner. The mandated tests from this Test Suite depend on the capabilities to which conformance is claimed.

The Bluetooth Qualification Program may employ tests to verify implementation robustness. The level of implementation robustness that is verified varies from one specification to another and may be revised for cause based on interoperability issues found in the market.

Such tests may verify:

- That claimed capabilities may be used in any order and any number of repetitions not excluded by the specification
- That capabilities enabled by the implementations are sustained over durations expected by the use case
- That the implementation gracefully handles any quantity of data expected by the use case
- That in cases where more than one valid interpretation of the specification exists, the implementation complies with at least one interpretation and gracefully handles other interpretations
- That the implementation is immune to attempted security exploits

A single execution of each of the required tests is required to constitute a Pass verdict. However, it is noted that to provide a foundation for interoperability, it is necessary that a qualified implementation consistently and repeatedly pass any of the applicable tests.

In any case, where a member finds an issue with the test plan generated by the Bluetooth SIG qualification tool, with the test case as described in the Test Suite, or with the test system utilized, the member is required to notify the responsible party via an erratum request such that the issue may be addressed.

4.1.3 Pass/Fail verdict conventions

Each test case has an Expected Outcome section. The IUT is granted the Pass verdict when all the detailed pass criteria conditions within the Expected Outcome section are met.

The convention in this Test Suite is that, unless there is a specific set of fail conditions outlined in the test case, the IUT fails the test case as soon as one of the pass criteria conditions cannot be met. If this occurs, then the outcome of the test is a Fail verdict.

4.2 Low Latency Audio Streaming – Unicast

Verify the correct implementation of Low Latency Audio Unicast Streaming suitable for gaming.

4.2.1 Low Latency Audio Streaming – UGG

Verify the correct implementation of unidirectional or bidirectional Low Latency Audio Unicast Streaming on the UGG suitable for gaming.

4.2.1.1 Low Latency Audio Streaming, Unidirectional – UGG

- Test Purpose

Verify that the UGG IUT can correctly send or receive unidirectional Low Latency Audio Streaming suitable for gaming.

- Reference

[5] 3.5

- Initial Condition

- The Lower Tester(s) are UGTs. There are one or two Lower Testers, as indicated in [Table 4.2](#).
- The Lower Tester(s)' supported Presentation_Delay range in its Sink ASE, if supported, includes 10000 as a supported value.
- The Lower Tester(s)' supported Presentation_Delay range in its Source ASE, if supported, includes 60000 as a supported value.
- The IUT and the Lower Tester(s) are bonded, and ACL connection(s) have been established.
- The IUT has discovered all the relevant services and characteristics of the Lower Tester(s).

- Test Case Configuration

Test Case	Audio Configuration	Legend	QoS Setting	Audio Channel Allocation	Lower Tester(s)
GMAP/UGG/LLU/BV-63-C [Low Latency Streaming - AC1: 32_1_gr]	AC 1	----->	32_1_gr	Not allocated	1
GMAP/UGG/LLU/BV-64-C [Low Latency Streaming - AC1: 32_2_gr]	AC 1	----->	32_2_gr	Not allocated	1
GMAP/UGG/LLU/BV-51-C [Low Latency Streaming - AC1: 48_1_gr]	AC 1	----->	48_1_gr	Not allocated	1
GMAP/UGG/LLU/BV-52-C [Low Latency Streaming - AC1: 48_2_gr]	AC 1	----->	48_2_gr	Not allocated	1
GMAP/UGG/LLU/BV-53-C [Low Latency Streaming - AC1: 48_3_gr]	AC 1	----->	48_3_gr	Not allocated	1
GMAP/UGG/LLU/BV-54-C [Low Latency Streaming - AC1: 48_4_gr]	AC 1	----->	48_4_gr	Not allocated	1
GMAP/UGG/LLU/BV-87-C [Low Latency Streaming - AC2: 16_1_gs]	AC 2	<-----	16_1_gs	Not allocated	1
GMAP/UGG/LLU/BV-88-C [Low Latency Streaming - AC2: 16_2_gs]	AC 2	<-----	16_2_gs	Not allocated	1
GMAP/UGG/LLU/BV-55-C [Low Latency Streaming - AC2: 32_1_gs]	AC 2	<-----	32_1_gs	Not allocated	1
GMAP/UGG/LLU/BV-56-C [Low Latency Streaming - AC2: 32_2_gs]	AC 2	<-----	32_2_gs	Not allocated	1
GMAP/UGG/LLU/BV-57-C [Low Latency Streaming - AC2: 48_1_gs]	AC 2	<-----	48_1_gs	Not allocated	1
GMAP/UGG/LLU/BV-58-C [Low Latency Streaming - AC2: 48_2_gs]	AC 2	<-----	48_2_gs	Not allocated	1
GMAP/UGG/LLU/BV-69-C [Low Latency Streaming - AC4: 32_1_gr]	AC 4	----->>	32_1_gr	0b11	1
GMAP/UGG/LLU/BV-70-C [Low Latency Streaming - AC4: 32_2_gr]	AC 4	----->>	32_2_gr	0b11	1
GMAP/UGG/LLU/BV-59-C [Low Latency Streaming - AC4: 48_1_gr]	AC 4	----->>	48_1_gr	0b11	1
GMAP/UGG/LLU/BV-60-C [Low Latency Streaming - AC4: 48_2_gr]	AC 4	----->>	48_2_gr	0b11	1
GMAP/UGG/LLU/BV-61-C [Low Latency Streaming - AC4: 48_3_gr]	AC 4	----->>	48_3_gr	0b11	1
GMAP/UGG/LLU/BV-62-C [Low Latency Streaming - AC4: 48_4_gr]	AC 4	----->>	48_4_gr	0b11	1
GMAP/UGG/LLU/BV-73-C [Low Latency Streaming - AC6i: 32_1_gr]	AC 6(i)	-----> ----->	32_1_gr	0b01 and 0b10	1
GMAP/UGG/LLU/BV-74-C [Low Latency Streaming - AC6i: 32_2_gr]	AC 6(i)	-----> ----->	32_2_gr	0b01 and 0b10	1
GMAP/UGG/LLU/BV-01-C [Low Latency Streaming - AC6i: 48_1_gr]	AC 6(i)	-----> ----->	48_1_gr	0b01 and 0b10	1
GMAP/UGG/LLU/BV-02-C [Low Latency Streaming - AC6i: 48_2_gr]	AC 6(i)	-----> ----->	48_2_gr	0b01 and 0b10	1



Test Case	Audio Configuration	Legend	QoS Setting	Audio Channel Allocation	Lower Tester(s)
GMAP/UGG/LLU/BV-03-C [Low Latency Streaming - AC6i: 48_3_gr]	AC 6(i)	-----> ----->	48_3_gr	0b01 and 0b10	1
GMAP/UGG/LLU/BV-04-C [Low Latency Streaming - AC6i: 48_4_gr]	AC 6(i)	-----> ----->	48_4_gr	0b01 and 0b10	1
GMAP/UGG/LLU/BV-75-C [Low Latency Streaming - AC6ii: 32_1_gr]	AC 6(ii)	-----> ----->	32_1_gr	0b01 and 0b10	2
GMAP/UGG/LLU/BV-76-C [Low Latency Streaming - AC6ii: 32_2_gr]	AC 6(ii)	-----> ----->	32_2_gr	0b01 and 0b10	2
GMAP/UGG/LLU/BV-05-C [Low Latency Streaming - AC6ii: 48_1_gr]	AC 6(ii)	-----> ----->	48_1_gr	0b01 and 0b10	2
GMAP/UGG/LLU/BV-06-C [Low Latency Streaming - AC6ii: 48_2_gr]	AC 6(ii)	-----> ----->	48_2_gr	0b01 and 0b10	2
GMAP/UGG/LLU/BV-07-C [Low Latency Streaming - AC6ii: 48_3_gr]	AC 6(ii)	-----> ----->	48_3_gr	0b01 and 0b10	2
GMAP/UGG/LLU/BV-08-C [Low Latency Streaming - AC6ii: 48_4_gr]	AC 6(ii)	-----> ----->	48_4_gr	0b01 and 0b10	2

Table 4.2: Low Latency Audio Streaming, Unidirectional – UGG test cases



- Test Procedure
 1. The Upper Tester commands the IUT to establish the streams described in [Table 4.2](#) with the Lower Tester(s). The Streaming_Audio_Context(s) are set to “Game”, using the CAP Unicast Audio Start procedure in [\[4\]](#).
 2. The IUT sends, or in the case of Audio Configuration 2 receives, low latency audio.
 3. The Upper Tester commands the IUT to disconnect its audio streams from the Lower Tester(s), using the CAP Unicast Audio Stop procedure in [\[4\]](#).

- Expected Outcome

Pass verdict

The IUT establishes, streams, or receives audio, then disconnects the audio streams described in [Table 4.2](#).

The Streaming_Audio_Context(s) are set to “Game”.

4.2.1.2 Low Latency Audio Streaming, Bidirectional – UGG

- Test Purpose

Verify that the UGG IUT can correctly send and receive Low Latency Audio Streaming suitable for gaming.
- Reference

[\[5\]](#) 3.5
- Initial Condition
 - The Lower Tester(s) are UGTs. There are one or two Lower Testers, as indicated in [Table 4.3](#).
 - The Lower Tester(s)' supported Presentation_Delay range in its Sink ASE includes 10000 as a supported value.
 - The Lower Tester(s)' supported Presentation_Delay range in its Source ASE includes 60000 as a supported value.
 - The IUT and the Lower Tester(s) are bonded, and ACL connection(s) have been established.
 - The IUT has discovered all the relevant services and characteristics of the Lower Tester.

- Test Case Configuration

Test Case	Audio Configuration	Legend	UGG to UGT QoS Setting	Audio Channel Allocation	UGT to UGG QoS Setting	Lower Tester(s)
GMAP/UGG/LLU/BV-89-C [Low Latency Streaming - AC3: 32_1_gr, 16_1_gs]	AC 3	<----->	32_1_gr	Not allocated	16_1_gs	1
GMAP/UGG/LLU/BV-90-C [Low Latency Streaming - AC3: 32_2_gr, 16_2_gs]	AC 3	<----->	32_2_gr	Not allocated	16_2_gs	1
GMAP/UGG/LLU/BV-91-C [Low Latency Streaming - AC3: 48_1_gr, 16_1_gs]	AC 3	<----->	48_1_gr	Not allocated	16_1_gs	1
GMAP/UGG/LLU/BV-92-C [Low Latency Streaming - AC3: 48_2_gr, 16_2_gs]	AC 3	<----->	48_2_gr	Not allocated	16_2_gs	1
GMAP/UGG/LLU/BV-65-C [Low Latency Streaming - AC3: 32_1_gr, 32_1_gs]	AC 3	<----->	32_1_gr	Not allocated	32_1_gs	1
GMAP/UGG/LLU/BV-66-C [Low Latency Streaming - AC3: 32_2_gr, 32_2_gs]	AC 3	<----->	32_2_gr	Not allocated	32_2_gs	1
GMAP/UGG/LLU/BV-09-C [Low Latency Streaming - AC3: 48_1_gr, 32_1_gs]	AC 3	<----->	48_1_gr	Not allocated	32_1_gs	1
GMAP/UGG/LLU/BV-10-C [Low Latency Streaming - AC3: 48_2_gr, 32_2_gs]	AC 3	<----->	48_2_gr	Not allocated	32_2_gs	1
GMAP/UGG/LLU/BV-11-C [Low Latency Streaming - AC3: 48_1_gr, 48_1_gs]	AC 3	<----->	48_1_gr	Not allocated	48_1_gs	1
GMAP/UGG/LLU/BV-12-C [Low Latency Streaming - AC3: 48_2_gr, 48_2_gs]	AC 3	<----->	48_2_gr	Not allocated	48_2_gs	1
GMAP/UGG/LLU/BV-13-C [Low Latency Streaming - AC3: 48_3_gr, 32_1_gs]	AC 3	<----->	48_3_gr	Not allocated	32_1_gs	1
GMAP/UGG/LLU/BV-14-C [Low Latency Streaming - AC3: 48_4_gr, 32_2_gs]	AC 3	<----->	48_4_gr	Not allocated	32_2_gs	1
GMAP/UGG/LLU/BV-67-C [Low Latency Streaming - AC3: 48_3_gr, 48_1_gs]	AC 3	<----->	48_3_gr	Not allocated	48_1_gs	1
GMAP/UGG/LLU/BV-68-C [Low Latency Streaming - AC3: 48_4_gr, 48_2_gs]	AC 3	<----->	48_4_gr	Not allocated	48_2_gs	1



Test Case	Audio Configuration	Legend	UGG to UGT QoS Setting	Audio Channel Allocation	UGT to UGG QoS Setting	Lower Tester(s)
GMAP/UGG/LLU/BV-93-C [Low Latency Streaming - AC5: 32_1_gr, 16_1_gs]	AC 5	<----->	32_1_gr	0b11	16_1_gs	1
GMAP/UGG/LLU/BV-94-C [Low Latency Streaming - AC5: 32_2_gr, 16_2_gs]	AC 5	<----->	32_2_gr	0b11	16_2_gs	1
GMAP/UGG/LLU/BV-95-C [Low Latency Streaming - AC5: 48_1_gr, 16_1_gs]	AC 5	<----->	48_1_gr	0b11	16_1_gs	1
GMAP/UGG/LLU/BV-96-C [Low Latency Streaming - AC5: 48_2_gr, 16_2_gs]	AC 5	<----->	48_2_gr	0b11	16_2_gs	1
GMAP/UGG/LLU/BV-71-C [Low Latency Streaming - AC5: 32_1_gr, 32_1_gs]	AC 5	<----->	32_1_gr	0b11	32_1_gs	1
GMAP/UGG/LLU/BV-72-C [Low Latency Streaming - AC5: 32_2_gr, 32_2_gs]	AC 5	<----->	32_2_gr	0b11	32_2_gs	1
GMAP/UGG/LLU/BV-15-C [Low Latency Streaming - AC5: 48_1_gr, 32_1_gs]	AC 5	<----->	48_1_gr	0b11	32_1_gs	1
GMAP/UGG/LLU/BV-16-C [Low Latency Streaming - AC5: 48_2_gr, 32_2_gs]	AC 5	<----->	48_2_gr	0b11	32_2_gs	1
GMAP/UGG/LLU/BV-17-C [Low Latency Streaming - AC5: 48_1_gr, 48_1_gs]	AC 5	<----->	48_1_gr	0b11	48_1_gs	1
GMAP/UGG/LLU/BV-18-C [Low Latency Streaming - AC5: 48_2_gr, 48_2_gs]	AC 5	<----->	48_2_gr	0b11	48_2_gs	1
GMAP/UGG/LLU/BV-19-C [Low Latency Streaming - AC5: 48_3_gr, 32_1_gs]	AC 5	<----->	48_3_gr	0b11	32_1_gs	1
GMAP/UGG/LLU/BV-20-C [Low Latency Streaming - AC5: 48_4_gr, 32_2_gs]	AC 5	<----->	48_4_gr	0b11	32_2_gs	1
GMAP/UGG/LLU/BV-97-C [Low Latency Streaming - AC7ii: 32_1_gr, 16_1_gs]	AC 7(ii)	-----> <-----	32_1_gr	Not allocated	16_1_gs	2
GMAP/UGG/LLU/BV-98-C [Low Latency Streaming - AC7ii: 32_2_gr, 16_2_gs]	AC 7(ii)	-----> <-----	32_2_gr	Not allocated	16_2_gs	2
GMAP/UGG/LLU/BV-99-C [Low Latency Streaming - AC7ii: 48_1_gr, 16_1_gs]	AC 7(ii)	-----> <-----	48_1_gr	Not allocated	16_1_gs	2



Test Case	Audio Configuration	Legend	UGG to UGT QoS Setting	Audio Channel Allocation	UGT to UGG QoS Setting	Lower Tester(s)
GMAP/UGG/LLU/BV-100-C [Low Latency Streaming - AC7ii: 48_2_gr, 16_2_gs]	AC 7(ii)	-----> <-----	48_2_gr	Not allocated	16_2_gs	2
GMAP/UGG/LLU/BV-41-C [Low Latency Streaming - AC7ii: 32_1_gr, 32_1_gs]	AC 7(ii)	-----> <-----	32_1_gr	Not allocated	32_1_gs	2
GMAP/UGG/LLU/BV-42-C [Low Latency Streaming - AC7ii: 32_2_gr, 32_2_gs]	AC 7(ii)	-----> <-----	32_2_gr	Not allocated	32_2_gs	2
GMAP/UGG/LLU/BV-21-C [Low Latency Streaming - AC7ii: 48_1_gr, 32_1_gs]	AC 7(ii)	-----> <-----	48_1_gr	Not allocated	32_1_gs	2
GMAP/UGG/LLU/BV-22-C [Low Latency Streaming - AC7ii: 48_2_gr, 32_2_gs]	AC 7(ii)	-----> <-----	48_2_gr	Not allocated	32_2_gs	2
GMAP/UGG/LLU/BV-23-C [Low Latency Streaming - AC7ii: 48_1_gr, 48_1_gs]	AC 7(ii)	-----> <-----	48_1_gr	Not allocated	48_1_gs	2
GMAP/UGG/LLU/BV-24-C [Low Latency Streaming - AC7ii: 48_2_gr, 48_2_gs]	AC 7(ii)	-----> <-----	48_2_gr	Not allocated	48_2_gs	2
GMAP/UGG/LLU/BV-25-C [Low Latency Streaming - AC7ii: 48_3_gr, 32_1_gs]	AC 7(ii)	-----> <-----	48_3_gr	Not allocated	32_1_gs	2
GMAP/UGG/LLU/BV-26-C [Low Latency Streaming - AC7ii: 48_4_gr, 32_2_gs]	AC 7(ii)	-----> <-----	48_4_gr	Not allocated	32_2_gs	2
GMAP/UGG/LLU/BV-77-C [Low Latency Streaming - AC7ii: 48_3_gr, 48_1_gs]	AC 7(ii)	-----> <-----	48_3_gr	Not allocated	48_1_gs	2
GMAP/UGG/LLU/BV-78-C [Low Latency Streaming - AC7ii: 48_4_gr, 48_2_gs]	AC 7(ii)	-----> <-----	48_4_gr	Not allocated	48_2_gs	2
GMAP/UGG/LLU/BV-101-C [Low Latency Streaming - AC8i: 32_1_gr, 16_1_gs]	AC 8(i)	-----> <----->	32_1_gr	0b01 and 0b10	16_1_gs	1
GMAP/UGG/LLU/BV-102-C [Low Latency Streaming - AC8i: 32_2_gr, 16_2_gs]	AC 8(i)	-----> <----->	32_2_gr	0b01 and 0b10	16_2_gs	1
GMAP/UGG/LLU/BV-103-C [Low Latency Streaming - AC8i: 48_1_gr, 16_1_gs]	AC 8(i)	-----> <----->	48_1_gr	0b01 and 0b10	16_1_gs	1
GMAP/UGG/LLU/BV-104-C [Low Latency Streaming - AC8i: 48_2_gr, 16_2_gs]	AC 8(i)	-----> <----->	48_2_gr	0b01 and 0b10	16_2_gs	1



Test Case	Audio Configuration	Legend	UGG to UGT QoS Setting	Audio Channel Allocation	UGT to UGG QoS Setting	Lower Tester(s)
GMAP/UGG/LLU/BV-79-C [Low Latency Streaming - AC8i: 32_1_gr, 32_1_gs]	AC 8(i)	-----> <-----	32_1_gr	0b01 and 0b10	32_1_gs	1
GMAP/UGG/LLU/BV-80-C [Low Latency Streaming - AC8i: 32_2_gr, 32_2_gs]	AC 8(i)	-----> <-----	32_2_gr	0b01 and 0b10	32_2_gs	1
GMAP/UGG/LLU/BV-27-C [Low Latency Streaming - AC8i: 48_1_gr, 32_1_gs]	AC 8(i)	-----> <-----	48_1_gr	0b01 and 0b10	32_1_gs	1
GMAP/UGG/LLU/BV-28-C [Low Latency Streaming - AC8i: 48_2_gr, 32_2_gs]	AC 8(i)	-----> <-----	48_2_gr	0b01 and 0b10	32_2_gs	1
GMAP/UGG/LLU/BV-29-C [Low Latency Streaming - AC8i: 48_1_gr, 48_1_gs]	AC 8(i)	-----> <-----	48_1_gr	0b01 and 0b10	48_1_gs	1
GMAP/UGG/LLU/BV-30-C [Low Latency Streaming - AC8i: 48_2_gr, 48_2_gs]	AC 8(i)	-----> <-----	48_2_gr	0b01 and 0b10	48_2_gs	1
GMAP/UGG/LLU/BV-31-C [Low Latency Streaming - AC8i: 48_3_gr, 32_1_gs]	AC 8(i)	-----> <-----	48_3_gr	0b01 and 0b10	32_1_gs	1
GMAP/UGG/LLU/BV-32-C [Low Latency Streaming - AC8i: 48_4_gr, 32_2_gs]	AC 8(i)	-----> <-----	48_4_gr	0b01 and 0b10	32_2_gs	1
GMAP/UGG/LLU/BV-105-C [Low Latency Streaming - AC8ii: 32_1_gr, 16_1_gs]	AC 8(ii)	-----> <-----	32_1_gr	0b01 and 0b10	16_1_gs	2
GMAP/UGG/LLU/BV-106-C [Low Latency Streaming - AC8ii: 32_2_gr, 16_2_gs]	AC 8(ii)	-----> <-----	32_2_gr	0b01 and 0b10	16_2_gs	2
GMAP/UGG/LLU/BV-107-C [Low Latency Streaming - AC8ii: 48_1_gr, 16_1_gs]	AC 8(ii)	-----> <-----	48_1_gr	0b01 and 0b10	16_1_gs	2
GMAP/UGG/LLU/BV-108-C [Low Latency Streaming - AC8ii: 48_2_gr, 16_2_gs]	AC 8(ii)	-----> <-----	48_2_gr	0b01 and 0b10	16_2_gs	2
GMAP/UGG/LLU/BV-81-C [Low Latency Streaming - AC8ii: 32_1_gr, 32_1_gs]	AC 8(ii)	-----> <-----	32_1_gr	0b01 and 0b10	32_1_gs	2
GMAP/UGG/LLU/BV-82-C [Low Latency Streaming - AC8ii: 32_2_gr, 32_2_gs]	AC 8(ii)	-----> <-----	32_2_gr	0b01 and 0b10	32_2_gs	2
GMAP/UGG/LLU/BV-33-C [Low Latency Streaming - AC8ii: 48_1_gr, 32_1_gs]	AC 8(ii)	-----> <-----	48_1_gr	0b01 and 0b10	32_1_gs	2



Test Case	Audio Configuration	Legend	UGG to UGT QoS Setting	Audio Channel Allocation	UGT to UGG QoS Setting	Lower Tester(s)
GMAP/UGG/LLU/BV-34-C [Low Latency Streaming - AC8ii: 48_2_gr, 32_2_gs]	AC 8(ii)	-----> <-----	48_2_gr	0b01 and 0b10	32_2_gs	2
GMAP/UGG/LLU/BV-35-C [Low Latency Streaming - AC8ii: 48_1_gr, 48_1_gs]	AC 8(ii)	-----> <-----	48_1_gr	0b01 and 0b10	48_1_gs	2
GMAP/UGG/LLU/BV-36-C [Low Latency Streaming - AC8ii: 48_2_gr, 48_2_gs]	AC 8(ii)	-----> <-----	48_2_gr	0b01 and 0b10	48_2_gs	2
GMAP/UGG/LLU/BV-37-C [Low Latency Streaming - AC8ii: 48_3_gr, 32_1_gs]	AC 8(ii)	-----> <-----	48_3_gr	0b01 and 0b10	32_1_gs	2
GMAP/UGG/LLU/BV-38-C [Low Latency Streaming - AC8ii: 48_4_gr, 32_2_gs]	AC 8(ii)	-----> <-----	48_4_gr	0b01 and 0b10	32_2_gs	2
GMAP/UGG/LLU/BV-109-C [Low Latency Streaming - AC11i: 32_1_gr, 16_1_gs]	AC 11(i)	<-----> <-----	32_1_gr	0b01 and 0b10	16_1_gs	1
GMAP/UGG/LLU/BV-110-C [Low Latency Streaming - AC11i: 32_2_gr, 16_2_gs]	AC 11(i)	<-----> <-----	32_2_gr	0b01 and 0b10	16_2_gs	1
GMAP/UGG/LLU/BV-111-C [Low Latency Streaming - AC11i: 48_1_gr, 16_1_gs]	AC 11(i)	<-----> <-----	48_1_gr	0b01 and 0b10	16_1_gs	1
GMAP/UGG/LLU/BV-112-C [Low Latency Streaming - AC11i: 48_2_gr, 16_2_gs]	AC 11(i)	<-----> <-----	48_2_gr	0b01 and 0b10	16_2_gs	1
GMAP/UGG/LLU/BV-83-C [Low Latency Streaming - AC11i: 32_1_gr, 32_1_gs]	AC 11(i)	<-----> <-----	32_1_gr	0b01 and 0b10	32_1_gs	1
GMAP/UGG/LLU/BV-84-C [Low Latency Streaming - AC11i: 32_2_gr, 32_2_gs]	AC 11(i)	<-----> <-----	32_2_gr	0b01 and 0b10	32_2_gs	1
GMAP/UGG/LLU/BV-39-C [Low Latency Streaming - AC11i: 48_1_gr, 32_1_gs]	AC 11(i)	<-----> <-----	48_1_gr	0b01 and 0b10	32_1_gs	1
GMAP/UGG/LLU/BV-40-C [Low Latency Streaming - AC11i: 48_2_gr, 32_2_gs]	AC 11(i)	<-----> <-----	48_2_gr	0b01 and 0b10	32_2_gs	1
GMAP/UGG/LLU/BV-43-C [Low Latency Streaming - AC11i: 48_3_gr, 32_1_gs]	AC 11(i)	<-----> <-----	48_3_gr	0b01 and 0b10	32_1_gs	1
GMAP/UGG/LLU/BV-44-C [Low Latency Streaming - AC11i: 48_4_gr, 32_2_gs]	AC 11(i)	<-----> <-----	48_4_gr	0b01 and 0b10	32_2_gs	1



Test Case	Audio Configuration	Legend	UGG to UGT QoS Setting	Audio Channel Allocation	UGT to UGG QoS Setting	Lower Tester(s)
GMAP/UGG/LLU/BV-113-C [Low Latency Streaming - AC11ii: 32_1_gr, 16_1_gs]	AC 11(ii)	<-----> <----->	32_1_gr	0b01 and 0b10	16_1_gs	2
GMAP/UGG/LLU/BV-114-C [Low Latency Streaming - AC11ii: 32_2_gr, 16_2_gs]	AC 11(ii)	<-----> <----->	32_2_gr	0b01 and 0b10	16_2_gs	2
GMAP/UGG/LLU/BV-115-C [Low Latency Streaming - AC11ii: 48_1_gr, 16_1_gs]	AC 11(ii)	<-----> <----->	48_1_gr	0b01 and 0b10	16_1_gs	2
GMAP/UGG/LLU/BV-116-C [Low Latency Streaming - AC11ii: 48_2_gr, 16_2_gs]	AC 11(ii)	<-----> <----->	48_2_gr	0b01 and 0b10	16_2_gs	2
GMAP/UGG/LLU/BV-85-C [Low Latency Streaming - AC11ii: 32_1_gr, 32_1_gs]	AC 11(ii)	<-----> <----->	32_1_gr	0b01 and 0b10	32_1_gs	2
GMAP/UGG/LLU/BV-86-C [Low Latency Streaming - AC11ii: 32_2_gr, 32_2_gs]	AC 11(ii)	<-----> <----->	32_2_gr	0b01 and 0b10	32_2_gs	2
GMAP/UGG/LLU/BV-45-C [Low Latency Streaming - AC11ii: 48_1_gr, 32_1_gs]	AC 11(ii)	<-----> <----->	48_1_gr	0b01 and 0b10	32_1_gs	2
GMAP/UGG/LLU/BV-46-C [Low Latency Streaming - AC11ii: 48_2_gr, 32_2_gs]	AC 11(ii)	<-----> <----->	48_2_gr	0b01 and 0b10	32_2_gs	2
GMAP/UGG/LLU/BV-49-C [Low Latency Streaming - AC11ii: 48_3_gr, 32_1_gs]	AC 11(ii)	<-----> <----->	48_3_gr	0b01 and 0b10	32_1_gs	2
GMAP/UGG/LLU/BV-50-C [Low Latency Streaming - AC11ii: 48_4_gr, 32_2_gs]	AC 11(ii)	<-----> <----->	48_4_gr	0b01 and 0b10	32_2_gs	2

Table 4.3: Low Latency Audio Streaming, Bidirectional – UGG test cases



- Test Procedure
 1. The Upper Tester commands the IUT to establish the streams described in [Table 4.3](#) with the Lower Tester(s). The Streaming_Audio_Context(s) are set to “Game” using the CAP Unicast Audio Start procedure in [\[4\]](#).
 2. The IUT sends and receives low latency audio.
 3. The Upper Tester commands the IUT to disconnect its audio streams from the Lower Tester(s) using the CAP Unicast Audio Stop procedure in [\[4\]](#).

- Expected Outcome

Pass verdict

The IUT establishes, streams, and receives audio, then disconnects the audio streams described in [Table 4.3](#).

The Streaming_Audio_Context(s) are set to “Game”.

4.2.2 Low Latency Audio Streaming – UGT

Verify the correct implementation of unidirectional or bidirectional Low Latency Audio Unicast Streaming on the UGT suitable for gaming.

4.2.2.1 Low Latency Audio Streaming, Unidirectional Render – UGT

- Test Purpose

Verify that the UGT IUT can correctly render Low Latency Audio Unicast Streaming suitable for gaming.

- Reference

[\[5\]](#) 3.5

- Initial Condition

- The Lower Tester is a UGG.
- The IUT and the Lower Tester are bonded, and an ACL connection has been established.
- The Lower Tester has discovered all relevant services and characteristics of the IUT.

- Test Case Configuration

Test Case	Audio Configuration	Legend	QoS Setting
GMAP/UGT/LLU/BV-49-C [Low Latency Streaming - AC1: 32_1_gr]	AC 1	----->	32_1_gr
GMAP/UGT/LLU/BV-50-C [Low Latency Streaming - AC1: 32_2_gr]	AC 1	----->	32_2_gr
GMAP/UGT/LLU/BV-37-C [Low Latency Streaming - AC1: 48_1_gr]	AC 1	----->	48_1_gr
GMAP/UGT/LLU/BV-38-C [Low Latency Streaming - AC1: 48_2_gr]	AC 1	----->	48_2_gr
GMAP/UGT/LLU/BV-39-C [Low Latency Streaming - AC1: 48_3_gr]	AC 1	----->	48_3_gr
GMAP/UGT/LLU/BV-40-C [Low Latency Streaming - AC1: 48_4_gr]	AC 1	----->	48_4_gr
GMAP/UGT/LLU/BV-55-C [Low Latency Streaming - AC4: 32_1_gr]	AC 4	----->>	32_1_gr
GMAP/UGT/LLU/BV-56-C [Low Latency Streaming - AC4: 32_2_gr]	AC 4	----->>	32_2_gr
GMAP/UGT/LLU/BV-41-C [Low Latency Streaming - AC4: 48_1_gr]	AC 4	----->>	48_1_gr
GMAP/UGT/LLU/BV-42-C [Low Latency Streaming - AC4: 48_2_gr]	AC 4	----->>	48_2_gr
GMAP/UGT/LLU/BV-43-C [Low Latency Streaming - AC4: 48_3_gr]	AC 4	----->>	48_3_gr
GMAP/UGT/LLU/BV-44-C [Low Latency Streaming - AC4: 48_4_gr]	AC 4	----->>	48_4_gr
GMAP/UGT/LLU/BV-59-C [Low Latency Streaming - AC6i: 32_1_gr]	AC 6(i)	-----> ----->	32_1_gr
GMAP/UGT/LLU/BV-60-C [Low Latency Streaming - AC6i: 32_2_gr]	AC 6(i)	-----> ----->	32_2_gr
GMAP/UGT/LLU/BV-01-C [Low Latency Streaming - AC6i: 48_1_gr]	AC 6(i)	-----> ----->	48_1_gr
GMAP/UGT/LLU/BV-02-C [Low Latency Streaming - AC6i: 48_2_gr]	AC 6(i)	-----> ----->	48_2_gr
GMAP/UGT/LLU/BV-03-C [Low Latency Streaming - AC6i: 48_3_gr]	AC 6(i)	-----> ----->	48_3_gr
GMAP/UGT/LLU/BV-04-C [Low Latency Streaming - AC6i: 48_4_gr]	AC 6(i)	-----> ----->	48_4_gr

Table 4.4: Low Latency Audio Streaming, Unidirectional – UGT test cases



- Test Procedure
 1. The Lower Tester establishes the streams described in [Table 4.4](#) with the IUT.
 2. The Lower Tester verifies that the IUT's Supported_Sink_Contexts and Available_Sink_Contexts fields include support for the "Game" Context Type.
 3. The IUT receives low latency audio. The audio stream payload from the Lower Tester can be simulated or empty.
 4. The Lower Tester disconnects its audio streams from the IUT.

- Expected Outcome

Pass verdict

The IUT receives audio over the audio streams described in [Table 4.4](#).

The IUT's Supported_Sink_Contexts and Available_Sink_Contexts fields include support for the "Game" Context Type.

4.2.2.2 Low Latency Audio Streaming, Bidirectional or Source – UGT

- Test Purpose

Verify that the UGT IUT can correctly send, or send and receive, Low Latency Audio Unicast Streaming suitable for gaming.

- Reference

[\[5\]](#) 3.5

- Initial Condition

- The Lower Tester is a UGG.
- The IUT and the Lower Tester are bonded, and an ACL connection has been established.
- The Lower Tester has discovered all relevant services and characteristics of the IUT.

- Test Case Configuration

Test Case	Audio Configuration	Legend	UGG to UGT QoS Setting	UGT to UGG QoS Setting
GMAP/UGT/LLU/BV-65-C [Low Latency Streaming - AC2: 16_1_gs]	AC 2	<-----	N/A	16_1_gs
GMAP/UGT/LLU/BV-66-C [Low Latency Streaming - AC2: 16_2_gs]	AC 2	<-----	N/A	16_2_gs
GMAP/UGT/LLU/BV-45-C [Low Latency Streaming - AC2: 32_1_gs]	AC 2	<-----	N/A	32_1_gs
GMAP/UGT/LLU/BV-46-C [Low Latency Streaming - AC2: 32_2_gs]	AC 2	<-----	N/A	32_2_gs
GMAP/UGT/LLU/BV-47-C [Low Latency Streaming - AC2: 48_1_gs]	AC 2	<-----	N/A	48_1_gs
GMAP/UGT/LLU/BV-48-C [Low Latency Streaming - AC2: 48_2_gs]	AC 2	<-----	N/A	48_2_gs
GMAP/UGT/LLU/BV-67-C [Low Latency Streaming - AC3: 32_1_gr, 16_1_gs]	AC 3	<----->	32_1_gr	16_1_gs
GMAP/UGT/LLU/BV-68-C [Low Latency Streaming - AC3: 32_2_gr, 16_2_gs]	AC 3	<----->	32_2_gr	16_2_gs
GMAP/UGT/LLU/BV-69-C [Low Latency Streaming - AC3: 48_1_gr, 16_1_gs]	AC 3	<----->	48_1_gr	16_1_gs
GMAP/UGT/LLU/BV-70-C [Low Latency Streaming - AC3: 48_2_gr, 16_2_gs]	AC 3	<----->	48_2_gr	16_2_gs
GMAP/UGT/LLU/BV-51-C [Low Latency Streaming - AC3: 32_1_gr, 32_1_gs]	AC 3	<----->	32_1_gr	32_1_gs
GMAP/UGT/LLU/BV-52-C [Low Latency Streaming - AC3: 32_2_gr, 32_2_gs]	AC 3	<----->	32_2_gr	32_2_gs
GMAP/UGT/LLU/BV-09-C [Low Latency Streaming - AC3: 48_1_gr, 32_1_gs]	AC 3	<----->	48_1_gr	32_1_gs
GMAP/UGT/LLU/BV-10-C [Low Latency Streaming - AC3: 48_2_gr, 32_2_gs]	AC 3	<----->	48_2_gr	32_2_gs
GMAP/UGT/LLU/BV-11-C [Low Latency Streaming - AC3: 48_1_gr, 48_1_gs]	AC 3	<----->	48_1_gr	48_1_gs
GMAP/UGT/LLU/BV-12-C [Low Latency Streaming - AC3: 48_2_gr, 48_2_gs]	AC 3	<----->	48_2_gr	48_2_gs
GMAP/UGT/LLU/BV-13-C [Low Latency Streaming - AC3: 48_3_gr, 32_1_gs]	AC 3	<----->	48_3_gr	32_1_gs
GMAP/UGT/LLU/BV-14-C [Low Latency Streaming - AC3: 48_4_gr, 32_2_gs]	AC 3	<----->	48_4_gr	32_2_gs
GMAP/UGT/LLU/BV-53-C [Low Latency Streaming - AC3: 48_3_gr, 48_1_gs]	AC 3	<----->	48_3_gr	48_1_gs
GMAP/UGT/LLU/BV-54-C [Low Latency Streaming - AC3: 48_4_gr, 48_2_gs]	AC 3	<----->	48_4_gr	48_2_gs
GMAP/UGT/LLU/BV-71-C [Low Latency Streaming - AC5: 32_1_gr, 16_1_gs]	AC 5	<----->>	32_1_gr	16_1_gs
GMAP/UGT/LLU/BV-72-C [Low Latency Streaming - AC5: 32_2_gr, 16_2_gs]	AC 5	<----->>	32_2_gr	16_2_gs
GMAP/UGT/LLU/BV-73-C [Low Latency Streaming - AC5: 48_1_gr, 16_1_gs]	AC 5	<----->>	48_1_gr	16_1_gs
GMAP/UGT/LLU/BV-74-C [Low Latency Streaming - AC5: 48_2_gr, 16_2_gs]	AC 5	<----->>	48_2_gr	16_2_gs
GMAP/UGT/LLU/BV-57-C [Low Latency Streaming - AC5: 32_1_gr, 32_1_gs]	AC 5	<----->>	32_1_gr	32_1_gs
GMAP/UGT/LLU/BV-58-C [Low Latency Streaming - AC5: 32_2_gr, 32_2_gs]	AC 5	<----->>	32_2_gr	32_2_gs



Test Case	Audio Configuration	Legend	UGG to UGT QoS Setting	UGT to UGG QoS Setting
GMAP/UGT/LLU/BV-15-C [Low Latency Streaming - AC5: 48_1_gr, 32_1_gs]	AC 5	<----->	48_1_gr	32_1_gs
GMAP/UGT/LLU/BV-16-C [Low Latency Streaming - AC5: 48_2_gr, 32_2_gs]	AC 5	<----->	48_2_gr	32_2_gs
GMAP/UGT/LLU/BV-17-C [Low Latency Streaming - AC5: 48_1_gr, 48_1_gs]	AC 5	<----->	48_1_gr	48_1_gs
GMAP/UGT/LLU/BV-18-C [Low Latency Streaming - AC5: 48_2_gr, 48_2_gs]	AC 5	<----->	48_2_gr	48_2_gs
GMAP/UGT/LLU/BV-19-C [Low Latency Streaming - AC5: 48_3_gr, 32_1_gs]	AC 5	<----->	48_3_gr	32_1_gs
GMAP/UGT/LLU/BV-20-C [Low Latency Streaming - AC5: 48_4_gr, 32_2_gs]	AC 5	<----->	48_4_gr	32_2_gs
GMAP/UGT/LLU/BV-75-C [Low Latency Streaming - AC8i: 32_1_gr, 16_1_gs]	AC 8(i)	-----> <----->	32_1_gr	16_1_gs
GMAP/UGT/LLU/BV-76-C [Low Latency Streaming - AC8i: 32_2_gr, 16_2_gs]	AC 8(i)	-----> <----->	32_2_gr	16_2_gs
GMAP/UGT/LLU/BV-77-C [Low Latency Streaming - AC8i: 48_1_gr, 16_1_gs]	AC 8(i)	-----> <----->	48_1_gr	16_1_gs
GMAP/UGT/LLU/BV-78-C [Low Latency Streaming - AC8i: 48_2_gr, 16_2_gs]	AC 8(i)	-----> <----->	48_2_gr	16_2_gs
GMAP/UGT/LLU/BV-61-C [Low Latency Streaming - AC8i: 32_1_gr, 32_1_gs]	AC 8(i)	-----> <----->	32_1_gr	32_1_gs
GMAP/UGT/LLU/BV-62-C [Low Latency Streaming - AC8i: 32_2_gr, 32_2_gs]	AC 8(i)	-----> <----->	32_2_gr	32_2_gs
GMAP/UGT/LLU/BV-25-C [Low Latency Streaming - AC8i: 48_1_gr, 32_1_gs]	AC 8(i)	-----> <----->	48_1_gr	32_1_gs
GMAP/UGT/LLU/BV-26-C [Low Latency Streaming - AC8i: 48_2_gr, 32_2_gs]	AC 8(i)	-----> <----->	48_2_gr	32_2_gs
GMAP/UGT/LLU/BV-27-C [Low Latency Streaming - AC8i: 48_1_gr, 48_1_gs]	AC 8(i)	-----> <----->	48_1_gr	48_1_gs
GMAP/UGT/LLU/BV-28-C [Low Latency Streaming - AC8i: 48_2_gr, 48_2_gs]	AC 8(i)	-----> <----->	48_2_gr	48_2_gs
GMAP/UGT/LLU/BV-29-C [Low Latency Streaming - AC8i: 48_3_gr, 32_1_gs]	AC 8(i)	-----> <----->	48_3_gr	32_1_gs
GMAP/UGT/LLU/BV-30-C [Low Latency Streaming - AC8i: 48_4_gr, 32_2_gs]	AC 8(i)	-----> <----->	48_4_gr	32_2_gs



Test Case	Audio Configuration	Legend	UGG to UGT QoS Setting	UGT to UGG QoS Setting
GMAP/UGT/LLU/BV-79-C [Low Latency Streaming - AC11i: 32_1_gr, 16_1_gs]	AC 11(i)	<-----> <----->	32_1_gr	16_1_gs
GMAP/UGT/LLU/BV-80-C [Low Latency Streaming - AC11i: 32_2_gr, 16_2_gs]	AC 11(i)	<-----> <----->	32_2_gr	16_2_gs
GMAP/UGT/LLU/BV-81-C [Low Latency Streaming - AC11i: 48_1_gr, 16_1_gs]	AC 11(i)	<-----> <----->	48_1_gr	16_1_gs
GMAP/UGT/LLU/BV-82-C [Low Latency Streaming - AC11i: 48_2_gr, 16_2_gs]	AC 11(i)	<-----> <----->	48_2_gr	16_2_gs
GMAP/UGT/LLU/BV-63-C [Low Latency Streaming - AC11i: 32_1_gr, 32_1_gs]	AC 11(i)	<-----> <----->	32_1_gr	32_1_gs
GMAP/UGT/LLU/BV-64-C [Low Latency Streaming - AC11i: 32_2_gr, 32_2_gs]	AC 11(i)	<-----> <----->	32_2_gr	32_2_gs
GMAP/UGT/LLU/BV-31-C [Low Latency Streaming - AC11i: 48_1_gr, 32_1_gs]	AC 11(i)	<-----> <----->	48_1_gr	32_1_gs
GMAP/UGT/LLU/BV-32-C [Low Latency Streaming - AC11i: 48_2_gr, 32_2_gs]	AC 11(i)	<-----> <----->	48_2_gr	32_2_gs
GMAP/UGT/LLU/BV-35-C [Low Latency Streaming - AC11i: 48_3_gr, 32_1_gs]	AC 11(i)	<-----> <----->	48_3_gr	32_1_gs
GMAP/UGT/LLU/BV-36-C [Low Latency Streaming - AC11i: 48_4_gr, 32_2_gs]	AC 11(i)	<-----> <----->	48_4_gr	32_2_gs

Table 4.5: Low Latency Audio Streaming, Bidirectional or Source – UGT test cases



- Test Procedure
 1. The Lower Tester establishes the streams described in [Table 4.5](#) with the IUT. If the Audio Configuration requires two UGTs, then the Lower Tester configures the CIG to provide one CIS for each UGT but will only establish the CIS with the IUT.
 2. The Lower Tester verifies that the IUT's Supported_Sink_Contexts and Available_Sink_Contexts fields include support for the "Game" Context Type.
 3. The IUT receives and sends low latency audio, except for Audio Configurations 2 and 7(ii), in which case it sends only low latency audio. The audio stream payload from the Lower Tester can be simulated or empty.
 4. The Lower Tester disconnects its audio streams from the IUT.

- Expected Outcome

Pass verdict

The IUT receives, or sends and receives, audio over the audio streams described in [Table 4.5](#).

The IUT's Supported_Sink_Contexts and Available_Sink_Contexts fields include support for the "Game" Context Type.

4.3 Low Latency Audio Streaming – Broadcast

Verify the correct implementation of Low Latency Audio Broadcast Streaming suitable for gaming.

4.3.1 Low Latency Audio Streaming – BGS

Verify the correct implementation of Low Latency Broadcast Audio Streaming on the BGS suitable for gaming.

- Test Purpose

Verify that the BGS IUT can correctly broadcast Low Latency Audio Streaming suitable for gaming.
- Reference

[\[5\]](#) 3.5
- Initial Condition
 - The Lower Tester is a BGR.

- Test Case Configuration













Test Case	Audio Configuration	Legend	QoS Setting	Audio Channel Allocation
GMAP/BGS/LLB/BV-05-C [Low Latency Streaming - AC12: 48_1_g]	AC 12		48_1_g	None
GMAP/BGS/LLB/BV-06-C [Low Latency Streaming - AC12: 48_2_g]	AC 12		48_2_g	None
GMAP/BGS/LLB/BV-07-C [Low Latency Streaming - AC12: 48_3_g]	AC 12		48_3_g	None
GMAP/BGS/LLB/BV-08-C [Low Latency Streaming - AC12: 48_4_g]	AC 12		48_4_g	None
GMAP/BGS/LLB/BV-01-C [Low Latency Streaming - AC13: 48_1_g]	AC 13		48_1_g	0b01 and 0b10
GMAP/BGS/LLB/BV-02-C [Low Latency Streaming - AC13: 48_2_g]	AC 13		48_2_g	0b01 and 0b10
GMAP/BGS/LLB/BV-03-C [Low Latency Streaming - AC13: 48_3_g]	AC 13		48_3_g	0b01 and 0b10
GMAP/BGS/LLB/BV-04-C [Low Latency Streaming - AC13: 48_4_g]	AC 13		48_4_g	0b01 and 0b10
GMAP/BGS/LLB/BV-09-C [Low Latency Streaming - AC14: 48_1_g]	AC 14		48_1_g	0b01 and 0b10
GMAP/BGS/LLB/BV-10-C [Low Latency Streaming - AC14: 48_2_g]	AC 14		48_2_g	0b01 and 0b10
GMAP/BGS/LLB/BV-11-C [Low Latency Streaming - AC14: 48_3_g]	AC 14		48_3_g	0b01 and 0b10
GMAP/BGS/LLB/BV-12-C [Low Latency Streaming - AC14: 48_4_g]	AC 14		48_4_g	0b01 and 0b10

Table 4.6: Low Latency Audio Streaming – BGS test cases



- Test Procedure
 1. The Upper Tester commands the IUT to broadcast the streams described in [Table 4.6](#) using the CAP Broadcast Audio Start procedure in [\[4\]](#).
 2. The IUT broadcasts low latency audio.
 3. The Lower Tester verifies that the IUT's Streaming_Audio_Contexts LTV structure in the BASE Metadata contains "Game" and that the Audio Channel Allocation matches [Table 4.6](#). If "None" is specified, then the IUT does not specify an Audio Channel Allocation.
 4. The Upper Tester commands the IUT to stop broadcasting its audio streams using the CAP Broadcast Audio Stop procedure in [\[4\]](#).
- Expected Outcome

Pass verdict

The Presentation_Delay given in the IUT's Basic Audio Announcement is 10000 µs.

The IUT broadcasts, streams audio over, then stops broadcasting the audio streams as described in [Table 4.6](#).

The Streaming_Audio_Contexts LTV structure in the BASE Metadata contains "Game".

The Audio Channel Allocation is correct. If "None" is specified, then the IUT does not specify an Audio Channel Allocation.
- Notes

Whether two BGRs or a single BGR synchronize to the streams produced by the IUT is not relevant to the testing of the BGS IUT.













4.3.2 Low Latency Audio Streaming – BGR

- Test Purpose

Verify that the BGR IUT can correctly receive Low Latency Audio Streaming suitable for gaming.
- Reference

[\[5\]](#) 3.5
- Initial Condition
 - The Lower Tester is a BGS.
 - The IUT exposes PAC records including the Sink Audio Location(s) as specified in [Table 4.7](#) or TSPX_IUT_Sink_Audio_Location defined in [IXIT \[7\]](#). If "None" is specified, then the IUT does not specify a Sink Audio Location.

- Test Case Configuration

Test Case	Audio Configuration	Legend	QoS Setting	Sink Audio Location(s)	BGR(s)
GMAP/BGR/LLB/BV-13-C [Low Latency Streaming - AC12: 48_1_g]	AC 12		48_1_g	None	1
GMAP/BGR/LLB/BV-14-C [Low Latency Streaming - AC12: 48_2_g]	AC 12		48_2_g	None	1
GMAP/BGR/LLB/BV-15-C [Low Latency Streaming - AC12: 48_3_g]	AC 12		48_3_g	None	1
GMAP/BGR/LLB/BV-16-C [Low Latency Streaming - AC12: 48_4_g]	AC 12		48_4_g	None	1
GMAP/BGR/LLB/BV-01-C [Low Latency Streaming - AC13: 48_1_g]	AC 13		48_1_g	TSPX_IUT_Sink_Audio_Location	2
GMAP/BGR/LLB/BV-02-C [Low Latency Streaming - AC13: 48_2_g]	AC 13		48_2_g	TSPX_IUT_Sink_Audio_Location	2
GMAP/BGR/LLB/BV-03-C [Low Latency Streaming - AC13: 48_3_g]	AC 13		48_3_g	TSPX_IUT_Sink_Audio_Location	2
GMAP/BGR/LLB/BV-04-C [Low Latency Streaming - AC13: 48_4_g]	AC 13		48_4_g	TSPX_IUT_Sink_Audio_Location	2
GMAP/BGR/LLB/BV-09-C [Low Latency Streaming - AC13: 48_1_g, right and left]	AC 13		48_1_g	0b01 and 0b10	1
GMAP/BGR/LLB/BV-10-C [Low Latency Streaming - AC13: 48_2_g, right and left]	AC 13		48_2_g	0b01 and 0b10	1
GMAP/BGR/LLB/BV-11-C [Low Latency Streaming - AC13: 48_3_g, right and left]	AC 13		48_3_g	0b01 and 0b10	1
GMAP/BGR/LLB/BV-12-C [Low Latency Streaming - AC13: 48_4_g, right and left]	AC 13		48_4_g	0b01 and 0b10	1
GMAP/BGR/LLB/BV-17-C [Low Latency Streaming - AC14: 48_1_g]	AC 14		48_1_g	0b01 and 0b10	1





Test Case	Audio Configuration	Legend	QoS Setting	Sink Audio Location(s)	BGR(s)
GMAP/BGR/LLB/BV-18-C [Low Latency Streaming - AC14: 48_2_g]	AC 14		48_2_g	0b01 and 0b10	1
GMAP/BGR/LLB/BV-19-C [Low Latency Streaming - AC14: 48_3_g]	AC 14		48_3_g	0b01 and 0b10	1
GMAP/BGR/LLB/BV-20-C [Low Latency Streaming - AC14: 48_4_g]	AC 14		48_4_g	0b01 and 0b10	1

Table 4.7: Low Latency Audio Streaming – BGR test cases

- Test Procedure
 1. The Lower Tester broadcasts low latency audio. The audio stream payload can be simulated or empty. The Presentation_Delay given in the Lower Tester's Basic Audio Announcement is 10000 μ s.
 2. The Upper Tester commands the IUT to synchronize to the stream(s) as described in [Table 4.7](#).
 3. The IUT reports the reception of the audio stream(s) to the Upper Tester.
 4. The Lower Tester stops broadcasting its audio streams.
- Expected Outcome

Pass verdict

The IUT synchronizes to the stream and reports the reception of the audio stream(s) to the Upper Tester.
- Notes

If two BGRs are required to complete the Audio Configuration described in [Table 4.7](#), then the BGR at the other Audio Location from the IUT is ignored in this test procedure.

4.4 Maximum latency

Verify that the IUT supports the correct Total System Delays in the Initiator (INI) to Acceptor (ACC) and UGG to UGT directions.

4.4.1 Audio In to SDU Sync max latency, INI to ACC

Verify that the UGG or BGS IUT supports an Audio In to SDU Sync Latency of 30 ms or less in the INI to ACC direction.

The test procedures in the following two sections reference the test strategy described in Section [3.2.1.2](#), [Audio In to SDU Sync Latency test strategy, Initiator to Acceptor, IUT is Initiator](#).

4.4.1.1 Audio In to SDU Sync max latency, UGG to UGT – UGG

- Test Purpose

Verify that the UGG IUT supports an Audio In to SDU Sync Latency of 30 ms or less in the UGG to UGT direction.
- Reference

[\[5\] 3.6](#)
- Initial Condition
 - The Lower Tester is a UGT.
 - The test system is configured as described in Section [3.2.1.2](#), [Audio In to SDU Sync Latency test strategy, Initiator to Acceptor, IUT is Initiator](#), with the IUT, one or two Lower Testers, Latency Timer, and Audio Signal Generator. An Upper Tester is also required to configure and command the IUT.
 - The IUT and the Lower Tester(s) are bonded and connected with an ACL connection.
 - The IUT has discovered all relevant services and characteristics of the Lower Tester.

- Test Case Configuration

Test Case	Audio Configuration	Legend	UGG to UGT QoS Setting	UGT to UGG QoS Setting	Lower Tester(s)
GMAP/UGG/MXLT/BV-55-C [Audio In to SDU Sync Latency - AC1: 32_1_gr]	AC 1	----->	32_1_gr	N/A	1
GMAP/UGG/MXLT/BV-56-C [Audio In to SDU Sync Latency - AC1: 32_2_gr]	AC 1	----->	32_2_gr	N/A	1
GMAP/UGG/MXLT/BV-37-C [Audio In to SDU Sync Latency - AC1: 48_1_gr]	AC 1	----->	48_1_gr	N/A	1
GMAP/UGG/MXLT/BV-38-C [Audio In to SDU Sync Latency - AC1: 48_2_gr]	AC 1	----->	48_2_gr	N/A	1
GMAP/UGG/MXLT/BV-39-C [Audio In to SDU Sync Latency - AC1: 48_3_gr]	AC 1	----->	48_3_gr	N/A	1
GMAP/UGG/MXLT/BV-40-C [Audio In to SDU Sync Latency - AC1: 48_4_gr]	AC 1	----->	48_4_gr	N/A	1
GMAP/UGG/MXLT/BV-128-C [Audio In to SDU Sync Latency - AC3: 32_1_gr, 16_1_gs]	AC 3	<----->	32_1_gr	16_1_gs	1
GMAP/UGG/MXLT/BV-129-C [Audio In to SDU Sync Latency - AC3: 32_2_gr, 16_2_gs]	AC 3	<----->	32_2_gr	16_2_gs	1
GMAP/UGG/MXLT/BV-130-C [Audio In to SDU Sync Latency - AC3: 48_1_gr, 16_1_gs]	AC 3	<----->	48_1_gr	16_1_gs	1
GMAP/UGG/MXLT/BV-131-C [Audio In to SDU Sync Latency - AC3: 48_2_gr, 16_2_gs]	AC 3	<----->	48_2_gr	16_2_gs	1
GMAP/UGG/MXLT/BV-57-C [Audio In to SDU Sync Latency - AC3: 32_1_gr, 32_1_gs]	AC 3	<----->	32_1_gr	32_1_gs	1
GMAP/UGG/MXLT/BV-58-C [Audio In to SDU Sync Latency - AC3: 32_2_gr, 32_2_gs]	AC 3	<----->	32_2_gr	32_2_gs	1
GMAP/UGG/MXLT/BV-01-C [Audio In to SDU Sync Latency - AC3: 48_1_gr, 32_1_gs]	AC 3	<----->	48_1_gr	32_1_gs	1
GMAP/UGG/MXLT/BV-02-C [Audio In to SDU Sync Latency - AC3: 48_2_gr, 32_2_gs]	AC 3	<----->	48_2_gr	32_2_gs	1
GMAP/UGG/MXLT/BV-45-C [Audio In to SDU Sync Latency - AC3: 48_1_gr, 48_1_gs]	AC 3	<----->	48_1_gr	48_1_gs	1



Test Case	Audio Configuration	Legend	UGG to UGT QoS Setting	UGT to UGG QoS Setting	Lower Tester(s)
GMAP/UGG/MXLT/BV-46-C [Audio In to SDU Sync Latency - AC3: 48_2_gr, 48_2_gs]	AC 3	<----->	48_2_gr	48_2_gs	1
GMAP/UGG/MXLT/BV-03-C [Audio In to SDU Sync Latency - AC3: 48_3_gr, 32_1_gs]	AC 3	<----->	48_3_gr	32_1_gs	1
GMAP/UGG/MXLT/BV-04-C [Audio In to SDU Sync Latency - AC3: 48_4_gr, 32_2_gs]	AC 3	<----->	48_4_gr	32_2_gs	1
GMAP/UGG/MXLT/BV-59-C [Audio In to SDU Sync Latency - AC3: 48_3_gr, 48_1_gs]	AC 3	<----->	48_3_gr	48_1_gs	1
GMAP/UGG/MXLT/BV-60-C [Audio In to SDU Sync Latency - AC3: 48_4_gr, 48_2_gs]	AC 3	<----->	48_4_gr	48_2_gs	1
GMAP/UGG/MXLT/BV-61-C [Audio In to SDU Sync Latency - AC4: 32_1_gr]	AC 4	----->>	32_1_gr	N/A	1
GMAP/UGG/MXLT/BV-62-C [Audio In to SDU Sync Latency - AC4: 32_2_gr]	AC 4	----->>	32_2_gr	N/A	1
GMAP/UGG/MXLT/BV-41-C [Audio In to SDU Sync Latency - AC4: 48_1_gr]	AC 4	----->>	48_1_gr	N/A	1
GMAP/UGG/MXLT/BV-42-C [Audio In to SDU Sync Latency - AC4: 48_2_gr]	AC 4	----->>	48_2_gr	N/A	1
GMAP/UGG/MXLT/BV-43-C [Audio In to SDU Sync Latency - AC4: 48_3_gr]	AC 4	----->>	48_3_gr	N/A	1
GMAP/UGG/MXLT/BV-44-C [Audio In to SDU Sync Latency - AC4: 48_4_gr]	AC 4	----->>	48_4_gr	N/A	1
GMAP/UGG/MXLT/BV-132-C [Audio In to SDU Sync Latency - AC5: 32_1_gr, 16_1_gs]	AC 5	<----->>	32_1_gr	16_1_gs	1
GMAP/UGG/MXLT/BV-133-C [Audio In to SDU Sync Latency - AC5: 32_2_gr, 16_2_gs]	AC 5	<----->>	32_2_gr	16_2_gs	1
GMAP/UGG/MXLT/BV-134-C [Audio In to SDU Sync Latency - AC5: 48_1_gr, 16_1_gs]	AC 5	<----->>	48_1_gr	16_1_gs	1
GMAP/UGG/MXLT/BV-135-C [Audio In to SDU Sync Latency - AC5: 48_2_gr, 16_2_gs]	AC 5	<----->>	48_2_gr	16_2_gs	1



Test Case	Audio Configuration	Legend	UGG to UGT QoS Setting	UGT to UGG QoS Setting	Lower Tester(s)
GMAP/UGG/MXLT/BV-63-C [Audio In to SDU Sync Latency - AC5: 32_1_gr, 32_1_gs]	AC 5	<----->	32_1_gr	32_1_gs	1
GMAP/UGG/MXLT/BV-64-C [Audio In to SDU Sync Latency - AC5: 32_2_gr, 32_2_gs]	AC 5	<----->	32_2_gr	32_2_gs	1
GMAP/UGG/MXLT/BV-05-C [Audio In to SDU Sync Latency - AC5: 48_1_gr, 32_1_gs]	AC 5	<----->	48_1_gr	32_1_gs	1
GMAP/UGG/MXLT/BV-06-C [Audio In to SDU Sync Latency - AC5: 48_2_gr, 32_2_gs]	AC 5	<----->	48_2_gr	32_2_gs	1
GMAP/UGG/MXLT/BV-47-C [Audio In to SDU Sync Latency - AC5: 48_1_gr, 48_1_gs]	AC 5	<----->	48_1_gr	48_1_gs	1
GMAP/UGG/MXLT/BV-48-C [Audio In to SDU Sync Latency - AC5: 48_2_gr, 48_2_gs]	AC 5	<----->	48_2_gr	48_2_gs	1
GMAP/UGG/MXLT/BV-07-C [Audio In to SDU Sync Latency - AC5: 48_3_gr, 32_1_gs]	AC 5	<----->	48_3_gr	32_1_gs	1
GMAP/UGG/MXLT/BV-08-C [Audio In to SDU Sync Latency - AC5: 48_4_gr, 32_2_gs]	AC 5	<----->	48_4_gr	32_2_gs	1
GMAP/UGG/MXLT/BV-65-C [Audio In to SDU Sync Latency - AC6i: 32_1_gr]	AC 6(i)	-----> ----->	32_1_gr	N/A	1
GMAP/UGG/MXLT/BV-66-C [Audio In to SDU Sync Latency - AC6i: 32_2_gr]	AC 6(i)	-----> ----->	32_2_gr	N/A	1
GMAP/UGG/MXLT/BV-29-C [Audio In to SDU Sync Latency - AC6i: 48_1_gr]	AC 6(i)	-----> ----->	48_1_gr	N/A	1
GMAP/UGG/MXLT/BV-30-C [Audio In to SDU Sync Latency - AC6i: 48_2_gr]	AC 6(i)	-----> ----->	48_2_gr	N/A	1
GMAP/UGG/MXLT/BV-31-C [Audio In to SDU Sync Latency - AC6i: 48_3_gr]	AC 6(i)	-----> ----->	48_3_gr	N/A	1
GMAP/UGG/MXLT/BV-32-C [Audio In to SDU Sync Latency - AC6i: 48_4_gr]	AC 6(i)	-----> ----->	48_4_gr	N/A	1
GMAP/UGG/MXLT/BV-67-C [Audio In to SDU Sync Latency - AC6ii: 32_1_gr]	AC 6(ii)	-----> ----->	32_1_gr	N/A	2



Test Case	Audio Configuration	Legend	UGG to UGT QoS Setting	UGT to UGG QoS Setting	Lower Tester(s)
GMAP/UGG/MXLT/BV-68-C [Audio In to SDU Sync Latency - AC6ii: 32_2_gr]	AC 6(ii)	-----> ----->	32_2_gr	N/A	2
GMAP/UGG/MXLT/BV-33-C [Audio In to SDU Sync Latency - AC6ii: 48_1_gr]	AC 6(ii)	-----> ----->	48_1_gr	N/A	2
GMAP/UGG/MXLT/BV-34-C [Audio In to SDU Sync Latency - AC6ii: 48_2_gr]	AC 6(ii)	-----> ----->	48_2_gr	N/A	2
GMAP/UGG/MXLT/BV-35-C [Audio In to SDU Sync Latency - AC6ii: 48_3_gr]	AC 6(ii)	-----> ----->	48_3_gr	N/A	2
GMAP/UGG/MXLT/BV-36-C [Audio In to SDU Sync Latency - AC6ii: 48_4_gr]	AC 6(ii)	-----> ----->	48_4_gr	N/A	2
GMAP/UGG/MXLT/BV-136-C [Audio In to SDU Sync Latency - AC7ii: 32_1_gr, 16_1_gs]	AC 7(ii)	-----> <-----	32_1_gr	16_1_gs	2
GMAP/UGG/MXLT/BV-137-C [Audio In to SDU Sync Latency - AC7ii: 32_2_gr, 16_2_gs]	AC 7(ii)	-----> <-----	32_2_gr	16_2_gs	2
GMAP/UGG/MXLT/BV-138-C [Audio In to SDU Sync Latency - AC7ii: 48_1_gr, 16_1_gs]	AC 7(ii)	-----> <-----	48_1_gr	16_1_gs	2
GMAP/UGG/MXLT/BV-139-C [Audio In to SDU Sync Latency - AC7ii: 48_2_gr, 16_2_gs]	AC 7(ii)	-----> <-----	48_2_gr	16_2_gs	2
GMAP/UGG/MXLT/BV-69-C [Audio In to SDU Sync Latency - AC7ii: 32_1_gr, 32_1_gs]	AC 7(ii)	-----> <-----	32_1_gr	32_1_gs	2
GMAP/UGG/MXLT/BV-70-C [Audio In to SDU Sync Latency - AC7ii: 32_2_gr, 32_2_gs]	AC 7(ii)	-----> <-----	32_2_gr	32_2_gs	2
GMAP/UGG/MXLT/BV-09-C [Audio In to SDU Sync Latency - AC7ii: 48_1_gr, 32_1_gs]	AC 7(ii)	-----> <-----	48_1_gr	32_1_gs	2
GMAP/UGG/MXLT/BV-10-C [Audio In to SDU Sync Latency - AC7ii: 48_2_gr, 32_2_gs]	AC 7(ii)	-----> <-----	48_2_gr	32_2_gs	2
GMAP/UGG/MXLT/BV-49-C [Audio In to SDU Sync Latency - AC7ii: 48_1_gr, 48_1_gs]	AC 7(ii)	-----> <-----	48_1_gr	48_1_gs	2
GMAP/UGG/MXLT/BV-50-C [Audio In to SDU Sync Latency - AC7ii: 48_2_gr, 48_2_gs]	AC 7(ii)	-----> <-----	48_2_gr	48_2_gs	2



Test Case	Audio Configuration	Legend	UGG to UGT QoS Setting	UGT to UGG QoS Setting	Lower Tester(s)
GMAP/UGG/MXLT/BV-11-C [Audio In to SDU Sync Latency - AC7ii: 48_3_gr, 32_1_gs]	AC 7(ii)	-----> <-----	48_3_gr	32_1_gs	2
GMAP/UGG/MXLT/BV-12-C [Audio In to SDU Sync Latency - AC7ii: 48_4_gr, 32_2_gs]	AC 7(ii)	-----> <-----	48_4_gr	32_2_gs	2
GMAP/UGG/MXLT/BV-71-C [Audio In to SDU Sync Latency - AC7ii: 48_3_gr, 48_1_gs]	AC 7(ii)	-----> <-----	48_3_gr	48_1_gs	2
GMAP/UGG/MXLT/BV-72-C [Audio In to SDU Sync Latency - AC7ii: 48_4_gr, 48_2_gs]	AC 7(ii)	-----> <-----	48_4_gr	48_2_gs	2
GMAP/UGG/MXLT/BV-140-C [Audio In to SDU Sync Latency - AC8i: 32_1_gr, 16_1_gs]	AC 8(i)	-----> <----->	32_1_gr	16_1_gs	1
GMAP/UGG/MXLT/BV-141-C [Audio In to SDU Sync Latency - AC8i: 32_2_gr, 16_2_gs]	AC 8(i)	-----> <----->	32_2_gr	16_2_gs	1
GMAP/UGG/MXLT/BV-142-C [Audio In to SDU Sync Latency - AC8i: 48_1_gr, 16_1_gs]	AC 8(i)	-----> <----->	48_1_gr	16_1_gs	1
GMAP/UGG/MXLT/BV-143-C [Audio In to SDU Sync Latency - AC8i: 48_2_gr, 16_2_gs]	AC 8(i)	-----> <----->	48_2_gr	16_2_gs	1
GMAP/UGG/MXLT/BV-73-C [Audio In to SDU Sync Latency - AC8i: 32_1_gr, 32_1_gs]	AC 8(i)	-----> <----->	32_1_gr	32_1_gs	1
GMAP/UGG/MXLT/BV-74-C [Audio In to SDU Sync Latency - AC8i: 32_2_gr, 32_2_gs]	AC 8(i)	-----> <----->	32_2_gr	32_2_gs	1
GMAP/UGG/MXLT/BV-13-C [Audio In to SDU Sync Latency - AC8i: 48_1_gr, 32_1_gs]	AC 8(i)	-----> <----->	48_1_gr	32_1_gs	1
GMAP/UGG/MXLT/BV-14-C [Audio In to SDU Sync Latency - AC8i: 48_2_gr, 32_2_gs]	AC 8(i)	-----> <----->	48_2_gr	32_2_gs	1
GMAP/UGG/MXLT/BV-51-C [Audio In to SDU Sync Latency - AC8i: 48_1_gr, 48_1_gs]	AC 8(i)	-----> <----->	48_1_gr	48_1_gs	1
GMAP/UGG/MXLT/BV-52-C [Audio In to SDU Sync Latency - AC8i: 48_2_gr, 48_2_gs]	AC 8(i)	-----> <----->	48_2_gr	48_2_gs	1
GMAP/UGG/MXLT/BV-15-C [Audio In to SDU Sync Latency - AC8i: 48_3_gr, 32_1_gs]	AC 8(i)	-----> <----->	48_3_gr	32_1_gs	1



Test Case	Audio Configuration	Legend	UGG to UGT QoS Setting	UGT to UGG QoS Setting	Lower Tester(s)
GMAP/UGG/MXLT/BV-16-C [Audio In to SDU Sync Latency - AC8i: 48_4_gr, 32_2_gs]	AC 8(i)	-----> <-----	48_4_gr	32_2_gs	1
GMAP/UGG/MXLT/BV-144-C [Audio In to SDU Sync Latency - AC8ii: 32_1_gr, 16_1_gs]	AC 8(ii)	-----> <-----	32_1_gr	16_1_gs	2
GMAP/UGG/MXLT/BV-145-C [Audio In to SDU Sync Latency - AC8ii: 32_2_gr, 16_2_gs]	AC 8(ii)	-----> <-----	32_2_gr	16_2_gs	2
GMAP/UGG/MXLT/BV-146-C [Audio In to SDU Sync Latency - AC8ii: 48_1_gr, 16_1_gs]	AC 8(ii)	-----> <-----	48_1_gr	16_1_gs	2
GMAP/UGG/MXLT/BV-147-C [Audio In to SDU Sync Latency - AC8ii: 48_2_gr, 16_2_gs]	AC 8(ii)	-----> <-----	48_2_gr	16_2_gs	2
GMAP/UGG/MXLT/BV-75-C [Audio In to SDU Sync Latency - AC8ii: 32_1_gr, 32_1_gs]	AC 8(ii)	-----> <-----	32_1_gr	32_1_gs	2
GMAP/UGG/MXLT/BV-76-C [Audio In to SDU Sync Latency - AC8ii: 32_2_gr, 32_2_gs]	AC 8(ii)	-----> <-----	32_2_gr	32_2_gs	2
GMAP/UGG/MXLT/BV-17-C [Audio In to SDU Sync Latency - AC8ii: 48_1_gr, 32_1_gs]	AC 8(ii)	-----> <-----	48_1_gr	32_1_gs	2
GMAP/UGG/MXLT/BV-18-C [Audio In to SDU Sync Latency - AC8ii: 48_2_gr, 32_2_gs]	AC 8(ii)	-----> <-----	48_2_gr	32_2_gs	2
GMAP/UGG/MXLT/BV-53-C [Audio In to SDU Sync Latency - AC8ii: 48_1_gr, 48_1_gs]	AC 8(ii)	-----> <-----	48_1_gr	48_1_gs	2
GMAP/UGG/MXLT/BV-54-C [Audio In to SDU Sync Latency - AC8ii: 48_2_gr, 48_2_gs]	AC 8(ii)	-----> <-----	48_2_gr	48_2_gs	2
GMAP/UGG/MXLT/BV-19-C [Audio In to SDU Sync Latency - AC8ii: 48_3_gr, 32_1_gs]	AC 8(ii)	-----> <-----	48_3_gr	32_1_gs	2
GMAP/UGG/MXLT/BV-20-C [Audio In to SDU Sync Latency - AC8ii: 48_4_gr, 32_2_gs]	AC 8(ii)	-----> <-----	48_4_gr	32_2_gs	2
GMAP/UGG/MXLT/BV-170-C [Audio In to SDU Sync Latency - AC11i: 32_1_gr, 16_1_gs]	AC 11(i)	<-----> <----->	32_1_gr	16_1_gs	1
GMAP/UGG/MXLT/BV-171-C [Audio In to SDU Sync Latency - AC11i: 32_2_gr, 16_2_gs]	AC 11(i)	<-----> <----->	32_2_gr	16_2_gs	1



Test Case	Audio Configuration	Legend	UGG to UGT QoS Setting	UGT to UGG QoS Setting	Lower Tester(s)
GMAP/UGG/MXLT/BV-172-C [Audio In to SDU Sync Latency - AC11i: 48_1_gr, 16_1_gs]	AC 11(i)	<-----> <----->	48_1_gr	16_1_gs	1
GMAP/UGG/MXLT/BV-173-C [Audio In to SDU Sync Latency - AC11i: 48_2_gr, 16_2_gs]	AC 11(i)	<-----> <----->	48_2_gr	16_2_gs	1
GMAP/UGG/MXLT/BV-174-C [Audio In to SDU Sync Latency - AC11i: 32_1_gr, 32_1_gs]	AC 11(i)	<-----> <----->	32_1_gr	32_1_gs	1
GMAP/UGG/MXLT/BV-175-C [Audio In to SDU Sync Latency - AC11i: 32_2_gr, 32_2_gs]	AC 11(i)	<-----> <----->	32_2_gr	32_2_gs	1
GMAP/UGG/MXLT/BV-176-C [Audio In to SDU Sync Latency - AC11i: 48_1_gr, 32_1_gs]	AC 11(i)	<-----> <----->	48_1_gr	32_1_gs	1
GMAP/UGG/MXLT/BV-177-C [Audio In to SDU Sync Latency - AC11i: 48_2_gr, 32_2_gs]	AC 11(i)	<-----> <----->	48_2_gr	32_2_gs	1
GMAP/UGG/MXLT/BV-178-C [Audio In to SDU Sync Latency - AC11i: 48_3_gr, 32_1_gs]	AC 11(i)	<-----> <----->	48_3_gr	32_1_gs	1
GMAP/UGG/MXLT/BV-179-C [Audio In to SDU Sync Latency - AC11i: 48_4_gr, 32_2_gs]	AC 11(i)	<-----> <----->	48_4_gr	32_2_gs	1
GMAP/UGG/MXLT/BV-180-C [Audio In to SDU Sync Latency - AC11ii: 32_1_gr, 16_1_gs]	AC 11(ii)	<-----> <----->	32_1_gr	16_1_gs	2
GMAP/UGG/MXLT/BV-181-C [Audio In to SDU Sync Latency - AC11ii: 32_2_gr, 16_2_gs]	AC 11(ii)	<-----> <----->	32_2_gr	16_2_gs	2
GMAP/UGG/MXLT/BV-182-C [Audio In to SDU Sync Latency - AC11ii: 48_1_gr, 16_1_gs]	AC 11(ii)	<-----> <----->	48_1_gr	16_1_gs	2
GMAP/UGG/MXLT/BV-183-C [Audio In to SDU Sync Latency - AC11ii: 48_2_gr, 16_2_gs]	AC 11(ii)	<-----> <----->	48_2_gr	16_2_gs	2
GMAP/UGG/MXLT/BV-184-C [Audio In to SDU Sync Latency - AC11ii: 32_1_gr, 32_1_gs]	AC 11(ii)	<-----> <----->	32_1_gr	32_1_gs	2
GMAP/UGG/MXLT/BV-185-C [Audio In to SDU Sync Latency - AC11ii: 32_2_gr, 32_2_gs]	AC 11(ii)	<-----> <----->	32_2_gr	32_2_gs	2
GMAP/UGG/MXLT/BV-186-C [Audio In to SDU Sync Latency - AC11ii: 48_1_gr, 32_1_gs]	AC 11(ii)	<-----> <----->	48_1_gr	32_1_gs	2

Test Case	Audio Configuration	Legend	UGG to UGT QoS Setting	UGT to UGG QoS Setting	Lower Tester(s)
GMAP/UGG/MXLT/BV-187-C [Audio In to SDU Sync Latency - AC11ii: 48_2_gr, 32_2_gs]	AC 11(ii)	<-----> <----->	48_2_gr	32_2_gs	2
GMAP/UGG/MXLT/BV-188-C [Audio In to SDU Sync Latency - AC11ii: 48_3_gr, 32_1_gs]	AC 11(ii)	<-----> <----->	48_3_gr	32_1_gs	2
GMAP/UGG/MXLT/BV-189-C [Audio In to SDU Sync Latency - AC11ii: 48_4_gr, 32_2_gs]	AC 11(ii)	<-----> <----->	48_4_gr	32_2_gs	2

Table 4.8: Audio In to SDU Sync max latency – UGG test cases

- Test Procedure
 1. The Upper Tester commands the IUT to establish audio streams to one or two Lower Testers in the Audio Configuration and QoS settings described in [Table 4.8](#). The IUT uses Level A parameters specified in [\[5\] Table 3.16: Recommended LL parameters for Unicast QoS configurations 8\(i\) and 8\(ii\)](#) and [\[5\] Table 3.17: Recommended LL parameters for Unicast QoS configurations 11\(i\) and 11\(ii\)](#).
 2. The Audio Signal Generator produces one or more audio bursts to the IUT's audio input.
 3. The Latency Timer detects the start of the audio sent to the IUT.
 4. The IUT sends audio in the established audio streams to one or two Lower Testers.
 5. The audio produced by the Lower Tester corresponding to the detected Audio In input is detected by the Latency Timer that measures the Total System Delay.

- Expected Outcome

Pass verdict

The Audio In to SDU Sync Latency is no greater than 30 ms. Measured latency up to 30.150 ms is acceptable.

4.4.1.2 Audio In to SDU Sync max latency – BGS

- Test Purpose

Verify that the BGS IUT supports an Audio In to SDU Sync Latency of 30 ms or less.
- Reference

[\[5\] 3.6](#)
- Initial Condition
 - The Lower Tester is a BGR.
 - The test system is configured as described in [Section 3.2.1.2, Audio In to SDU Sync Latency test strategy, Initiator to Acceptor, IUT is Initiator](#), with the IUT, Lower Tester, Latency Timer, and Audio Signal Generator. An Upper Tester is also required to configure and command the IUT.
 - The IUT is configured for a Presentation Delay of 10 ms.

- Test Case Configuration

Test Case	Audio Configuration	Legend	QoS Setting
GMAP/BGS/MXLT/BV-05-C [Audio In to SDU Sync Latency - AC12: 48_1_g]	AC 12		48_1_g
GMAP/BGS/MXLT/BV-06-C [Audio In to SDU Sync Latency - AC12: 48_2_g]	AC 12		48_2_g
GMAP/BGS/MXLT/BV-07-C [Audio In to SDU Sync Latency - AC12: 48_3_g]	AC 12		48_3_g
GMAP/BGS/MXLT/BV-08-C [Audio In to SDU Sync Latency - AC12: 48_4_g]	AC 12		48_4_g
GMAP/BGS/MXLT/BV-01-C [Audio In to SDU Sync Latency - AC13: 48_1_g]	AC 13		48_1_g
GMAP/BGS/MXLT/BV-02-C [Audio In to SDU Sync Latency - AC13: 48_2_g]	AC 13		48_2_g
GMAP/BGS/MXLT/BV-03-C [Audio In to SDU Sync Latency - AC13: 48_3_g]	AC 13		48_3_g
GMAP/BGS/MXLT/BV-04-C [Audio In to SDU Sync Latency - AC13: 48_4_g]	AC 13		48_4_g
GMAP/BGS/MXLT/BV-09-C [Audio In to SDU Sync Latency - AC14: 48_1_g]	AC 14		48_1_g
GMAP/BGS/MXLT/BV-10-C [Audio In to SDU Sync Latency - AC14: 48_2_g]	AC 14		48_2_g
GMAP/BGS/MXLT/BV-11-C [Audio In to SDU Sync Latency - AC14: 48_3_g]	AC 14		48_3_g
GMAP/BGS/MXLT/BV-12-C [Audio In to SDU Sync Latency - AC14: 48_4_g]	AC 14		48_4_g

Table 4.9: Audio In to SDU Sync max latency – BGS test cases

- Test Procedure
 1. The Upper Tester commands the IUT to broadcast audio streams in the Audio Configuration and QoS Setting described in [Table 4.9](#). The IUT uses Level A parameters specified in [\[5\] Table 3.22: Recommended LL parameters for Broadcast QoS configuration](#).
 2. The Lower Tester synchronizes to one of the IUT's broadcast audio streams.
 3. The Audio Signal Generator produces one or more audio bursts to the IUT's audio input.
 4. The Latency Timer detects the start of the audio sent to the IUT.
 5. The IUT broadcasts audio in the established audio streams to one or two Lower Testers.
 6. The audio produced by the Lower Tester is detected by the Latency Timer that measures the Total System Delay.

- Expected Outcome

Pass verdict

The Audio In to SDU Sync Latency is no greater than 30 ms. Measured latency of up to 30.150 ms is acceptable.

4.4.2 SDU Sync to Audio Out max latency, INI to ACC

Verify that the UGT or BGR IUT supports an SDU Sync to Audio Out Latency of 10 ms in the INI to ACC direction.

The test procedures in the following two sections reference the test strategy described in [Section 3.2.1.3, SDU Sync to Audio Out Latency test strategy, Initiator to Acceptor, IUT is Acceptor](#).

4.4.2.1 SDU Sync to Audio Out max latency – UGT

- Test Purpose

Verify that the UGT IUT supports an SDU Sync to Audio Out Latency of 10 ms.
- Reference

[\[5\] 3.6](#)
- Initial Condition
 - The Lower Tester is a UGG.
 - The test system is configured as described in [Section 3.2.1.3, SDU Sync to Audio Out Latency test strategy, Initiator to Acceptor, IUT is Acceptor](#), with the IUT, Lower Tester, Latency Timer, and Audio Signal Generator. An Upper Tester may be required to configure and command the IUT.
 - The IUT and the Lower Tester are bonded and connected with an ACL connection.
 - The Lower Tester has discovered all relevant services and characteristics of the IUT.

- Test Case Configuration

Test Case	Audio Configuration	Legend	UGG to UGT QoS Setting	UGT to UGG QoS Setting
GMAP/UGT/MXLT/BV-03-C [SDU Sync to Audio Out Latency - AC1: 32_1_gr]	AC 1	----->	32_1_gr	N/A
GMAP/UGT/MXLT/BV-04-C [SDU Sync to Audio Out Latency - AC1: 32_2_gr]	AC 1	----->	32_2_gr	N/A
GMAP/UGT/MXLT/BV-36-C [SDU Sync to Audio Out Latency - AC1: 48_1_gr]	AC 1	----->	48_1_gr	N/A
GMAP/UGT/MXLT/BV-37-C [SDU Sync to Audio Out Latency - AC1: 48_2_gr]	AC 1	----->	48_2_gr	N/A
GMAP/UGT/MXLT/BV-38-C [SDU Sync to Audio Out Latency - AC1: 48_3_gr]	AC 1	----->	48_3_gr	N/A
GMAP/UGT/MXLT/BV-39-C [SDU Sync to Audio Out Latency - AC1: 48_4_gr]	AC 1	----->	48_4_gr	N/A
GMAP/UGT/MXLT/BV-110-C [SDU Sync to Audio Out Latency - AC3: 32_1_gr, 16_1_gs]	AC 3	<----->	32_1_gr	16_1_gs
GMAP/UGT/MXLT/BV-111-C [SDU Sync to Audio Out Latency - AC3: 32_2_gr, 16_2_gs]	AC 3	<----->	32_2_gr	16_2_gs
GMAP/UGT/MXLT/BV-112-C [SDU Sync to Audio Out Latency - AC3: 48_1_gr, 16_1_gs]	AC 3	<----->	48_1_gr	16_1_gs
GMAP/UGT/MXLT/BV-113-C [SDU Sync to Audio Out Latency - AC3: 48_2_gr, 16_2_gs]	AC 3	<----->	48_2_gr	16_2_gs
GMAP/UGT/MXLT/BV-05-C [SDU Sync to Audio Out Latency - AC3: 32_1_gr, 32_1_gs]	AC 3	<----->	32_1_gr	32_1_gs
GMAP/UGT/MXLT/BV-06-C [SDU Sync to Audio Out Latency - AC3: 32_2_gr, 32_2_gs]	AC 3	<----->	32_2_gr	32_2_gs
GMAP/UGT/MXLT/BV-44-C [SDU Sync to Audio Out Latency - AC3: 48_1_gr, 32_1_gs]	AC 3	<----->	48_1_gr	32_1_gs
GMAP/UGT/MXLT/BV-45-C [SDU Sync to Audio Out Latency - AC3: 48_2_gr, 32_2_gs]	AC 3	<----->	48_2_gr	32_2_gs
GMAP/UGT/MXLT/BV-52-C [SDU Sync to Audio Out Latency - AC3: 48_1_gr, 48_1_gs]	AC 3	<----->	48_1_gr	48_1_gs
GMAP/UGT/MXLT/BV-53-C [SDU Sync to Audio Out Latency - AC3: 48_2_gr, 48_2_gs]	AC 3	<----->	48_2_gr	48_2_gs
GMAP/UGT/MXLT/BV-46-C [SDU Sync to Audio Out Latency - AC3: 48_3_gr, 32_1_gs]	AC 3	<----->	48_3_gr	32_1_gs
GMAP/UGT/MXLT/BV-47-C [SDU Sync to Audio Out Latency - AC3: 48_4_gr, 32_2_gs]	AC 3	<----->	48_4_gr	32_2_gs
GMAP/UGT/MXLT/BV-07-C [SDU Sync to Audio Out Latency - AC3: 48_3_gr, 48_1_gs]	AC 3	<----->	48_3_gr	48_1_gs
GMAP/UGT/MXLT/BV-08-C [SDU Sync to Audio Out Latency - AC3: 48_4_gr, 48_2_gs]	AC 3	<----->	48_4_gr	48_2_gs
GMAP/UGT/MXLT/BV-09-C [SDU Sync to Audio Out Latency - AC4: 32_1_gr]	AC 4	----->>	32_1_gr	N/A
GMAP/UGT/MXLT/BV-10-C [SDU Sync to Audio Out Latency - AC4: 32_2_gr]	AC 4	----->>	32_2_gr	N/A
GMAP/UGT/MXLT/BV-48-C [SDU Sync to Audio Out Latency - AC4: 48_1_gr]	AC 4	----->>	48_1_gr	N/A
GMAP/UGT/MXLT/BV-49-C [SDU Sync to Audio Out Latency - AC4: 48_2_gr]	AC 4	----->>	48_2_gr	N/A
GMAP/UGT/MXLT/BV-50-C [SDU Sync to Audio Out Latency - AC4: 48_3_gr]	AC 4	----->>	48_3_gr	N/A



Test Case	Audio Configuration	Legend	UGG to UGT QoS Setting	UGT to UGG QoS Setting
GMAP/UGT/MXLT/BV-51-C [SDU Sync to Audio Out Latency - AC4: 48_4_gr]	AC 4	----->>	48_4_gr	N/A
GMAP/UGT/MXLT/BV-114-C [SDU Sync to Audio Out Latency - AC5: 32_1_gr, 16_1_gs]	AC 5	<----->>	32_1_gr	16_1_gs
GMAP/UGT/MXLT/BV-115-C [SDU Sync to Audio Out Latency - AC5: 32_2_gr, 16_2_gs]	AC 5	<----->>	32_2_gr	16_2_gs
GMAP/UGT/MXLT/BV-116-C [SDU Sync to Audio Out Latency - AC5: 48_1_gr, 16_1_gs]	AC 5	<----->>	48_1_gr	16_1_gs
GMAP/UGT/MXLT/BV-117-C [SDU Sync to Audio Out Latency - AC5: 48_2_gr, 16_2_gs]	AC 5	<----->>	48_2_gr	16_2_gs
GMAP/UGT/MXLT/BV-11-C [SDU Sync to Audio Out Latency - AC5: 32_1_gr, 32_1_gs]	AC 5	<----->>	32_1_gr	32_1_gs
GMAP/UGT/MXLT/BV-12-C [SDU Sync to Audio Out Latency - AC5: 32_2_gr, 32_2_gs]	AC 5	<----->>	32_2_gr	32_2_gs
GMAP/UGT/MXLT/BV-20-C [SDU Sync to Audio Out Latency - AC5: 48_1_gr, 32_1_gs]	AC 5	<----->>	48_1_gr	32_1_gs
GMAP/UGT/MXLT/BV-21-C [SDU Sync to Audio Out Latency - AC5: 48_2_gr, 32_2_gs]	AC 5	<----->>	48_2_gr	32_2_gs
GMAP/UGT/MXLT/BV-54-C [SDU Sync to Audio Out Latency - AC5: 48_1_gr, 48_1_gs]	AC 5	<----->>	48_1_gr	48_1_gs
GMAP/UGT/MXLT/BV-55-C [SDU Sync to Audio Out Latency - AC5: 48_2_gr, 48_2_gs]	AC 5	<----->>	48_2_gr	48_2_gs
GMAP/UGT/MXLT/BV-22-C [SDU Sync to Audio Out Latency - AC5: 48_3_gr, 32_1_gs]	AC 5	<----->>	48_3_gr	32_1_gs
GMAP/UGT/MXLT/BV-23-C [SDU Sync to Audio Out Latency - AC5: 48_4_gr, 32_2_gs]	AC 5	<----->>	48_4_gr	32_2_gs
GMAP/UGT/MXLT/BV-13-C [SDU Sync to Audio Out Latency - AC6i: 32_1_gr]	AC 6(i)	-----> ----->	32_1_gr	N/A
GMAP/UGT/MXLT/BV-14-C [SDU Sync to Audio Out Latency - AC6i: 32_2_gr]	AC 6(i)	-----> ----->	32_2_gr	N/A
GMAP/UGT/MXLT/BV-32-C [SDU Sync to Audio Out Latency - AC6i: 48_1_gr]	AC 6(i)	-----> ----->	48_1_gr	N/A
GMAP/UGT/MXLT/BV-33-C [SDU Sync to Audio Out Latency - AC6i: 48_2_gr]	AC 6(i)	-----> ----->	48_2_gr	N/A
GMAP/UGT/MXLT/BV-34-C [SDU Sync to Audio Out Latency - AC6i: 48_3_gr]	AC 6(i)	-----> ----->	48_3_gr	N/A
GMAP/UGT/MXLT/BV-35-C [SDU Sync to Audio Out Latency - AC6i: 48_4_gr]	AC 6(i)	-----> ----->	48_4_gr	N/A
GMAP/UGT/MXLT/BV-118-C [SDU Sync to Audio Out Latency - AC8i: 32_1_gr, 16_1_gs]	AC 8(i)	-----> <----->	32_1_gr	16_1_gs



Test Case	Audio Configuration	Legend	UGG to UGT QoS Setting	UGT to UGG QoS Setting
GMAP/UGT/MXLT/BV-119-C [SDU Sync to Audio Out Latency - AC8i: 32_2_gr, 16_2_gs]	AC 8(i)	-----> <-----	32_2_gr	16_2_gs
GMAP/UGT/MXLT/BV-120-C [SDU Sync to Audio Out Latency - AC8i: 48_1_gr, 16_1_gs]	AC 8(i)	-----> <-----	48_1_gr	16_1_gs
GMAP/UGT/MXLT/BV-121-C [SDU Sync to Audio Out Latency - AC8i: 48_2_gr, 16_2_gs]	AC 8(i)	-----> <-----	48_2_gr	16_2_gs
GMAP/UGT/MXLT/BV-15-C [SDU Sync to Audio Out Latency - AC8i: 32_1_gr, 32_1_gs]	AC 8(i)	-----> <-----	32_1_gr	32_1_gs
GMAP/UGT/MXLT/BV-16-C [SDU Sync to Audio Out Latency - AC8i: 32_2_gr, 32_2_gs]	AC 8(i)	-----> <-----	32_2_gr	32_2_gs
GMAP/UGT/MXLT/BV-24-C [SDU Sync to Audio Out Latency - AC8i: 48_1_gr, 32_1_gs]	AC 8(i)	-----> <-----	48_1_gr	32_1_gs
GMAP/UGT/MXLT/BV-25-C [SDU Sync to Audio Out Latency - AC8i: 48_2_gr, 32_2_gs]	AC 8(i)	-----> <-----	48_2_gr	32_2_gs
GMAP/UGT/MXLT/BV-01-C [SDU Sync to Audio Out Latency - AC8i: 48_1_gr, 48_1_gs]	AC 8(i)	-----> <-----	48_1_gr	48_1_gs
GMAP/UGT/MXLT/BV-02-C [SDU Sync to Audio Out Latency - AC8i: 48_2_gr, 48_2_gs]	AC 8(i)	-----> <-----	48_2_gr	48_2_gs
GMAP/UGT/MXLT/BV-26-C [SDU Sync to Audio Out Latency - AC8i: 48_3_gr, 32_1_gs]	AC 8(i)	-----> <-----	48_3_gr	32_1_gs
GMAP/UGT/MXLT/BV-27-C [SDU Sync to Audio Out Latency - AC8i: 48_4_gr, 32_2_gs]	AC 8(i)	-----> <-----	48_4_gr	32_2_gs
GMAP/UGT/MXLT/BV-136-C [SDU Sync to Audio Out Latency - AC11i: 32_1_gr, 16_1_gs]	AC 11(i)	<-----> <-----	32_1_gr	16_1_gs
GMAP/UGT/MXLT/BV-137-C [SDU Sync to Audio Out Latency - AC11i: 32_2_gr, 16_2_gs]	AC 11(i)	<-----> <-----	32_2_gr	16_2_gs
GMAP/UGT/MXLT/BV-138-C [SDU Sync to Audio Out Latency - AC11i: 48_1_gr, 16_1_gs]	AC 11(i)	<-----> <-----	48_1_gr	16_1_gs
GMAP/UGT/MXLT/BV-139-C [SDU Sync to Audio Out Latency - AC11i: 48_2_gr, 16_2_gs]	AC 11(i)	<-----> <-----	48_2_gr	16_2_gs



Test Case	Audio Configuration	Legend	UGG to UGT QoS Setting	UGT to UGG QoS Setting
GMAP/UGT/MXLT/BV-140-C [SDU Sync to Audio Out Latency - AC11i: 32_1_gr, 32_1_gs]	AC 11(i)	<-----> <----->	32_1_gr	32_1_gs
GMAP/UGT/MXLT/BV-141-C [SDU Sync to Audio Out Latency - AC11i: 32_2_gr, 32_2_gs]	AC 11(i)	<-----> <----->	32_2_gr	32_2_gs
GMAP/UGT/MXLT/BV-142-C [SDU Sync to Audio Out Latency - AC11i: 48_1_gr, 32_1_gs]	AC 11(i)	<-----> <----->	48_1_gr	32_1_gs
GMAP/UGT/MXLT/BV-143-C [SDU Sync to Audio Out Latency - AC11i: 48_2_gr, 32_2_gs]	AC 11(i)	<-----> <----->	48_2_gr	32_2_gs
GMAP/UGT/MXLT/BV-144-C [SDU Sync to Audio Out Latency - AC11i: 48_3_gr, 32_1_gs]	AC 11(i)	<-----> <----->	48_3_gr	32_1_gs
GMAP/UGT/MXLT/BV-145-C [SDU Sync to Audio Out Latency - AC11i: 48_4_gr, 32_2_gs]	AC 11(i)	<-----> <----->	48_4_gr	32_2_gs

Table 4.10: SDU Sync to Audio Out max latency – UGT test cases

- Test Procedure
 1. The Lower Tester establishes one or more audio streams with the IUT in the Audio Configuration and QoS Settings described in [Table 4.10](#). It uses Level A parameters specified in [\[5\] Table 3.16: Recommended LL parameters for Unicast QoS configurations 8\(i\) and 8\(ii\)](#) and [\[5\] Table 3.17: Recommended LL parameters for Unicast QoS configurations 11\(i\) and 11\(ii\)](#).
 2. The Audio Signal Generator produces one or more audio bursts to the Lower Tester and is detected by the Latency Timer.
 3. The audio produced by the IUT is detected by the Latency Timer that measures the Total System Delay.

- Expected Outcome

Pass verdict

The SDU Sync to Audio Out Latency is 10 ms. Measured latency between 9.8875 ms and 10.1125 ms is acceptable.

4.4.2.2 SDU Sync to Audio Out max latency – BGR

- Test Purpose

Verify that the BGR IUT supports an SDU Sync to Audio Out Latency of 10 ms.
- Reference

[\[5\] 3.6](#)
- Initial Condition
 - The Lower Tester is a BGS.
 - The test system is configured as described in [Section 3.2.1.3, SDU Sync to Audio Out Latency test strategy, Initiator to Acceptor, IUT is Acceptor](#), with the IUT, Lower Tester, Latency Timer, and Audio Signal Generator. An Upper Tester is also required to configure and command the IUT.

- Test Case Configuration

Test Case	Audio Configuration	Legend	QoS Setting
GMAP/BGR/MXLT/BV-05-C [SDU Sync to Audio Out Latency - AC12: 48_1_g]	AC 12		48_1_g
GMAP/BGR/MXLT/BV-06-C [SDU Sync to Audio Out Latency - AC12: 48_2_g]	AC 12		48_2_g
GMAP/BGR/MXLT/BV-07-C [SDU Sync to Audio Out Latency - AC12: 48_3_g]	AC 12		48_3_g
GMAP/BGR/MXLT/BV-08-C [SDU Sync to Audio Out Latency - AC12: 48_4_g]	AC 12		48_4_g
GMAP/BGR/MXLT/BV-01-C [SDU Sync to Audio Out Latency - AC13: 48_1_g]	AC 13		48_1_g
GMAP/BGR/MXLT/BV-02-C [SDU Sync to Audio Out Latency - AC13: 48_2_g]	AC 13		48_2_g
GMAP/BGR/MXLT/BV-03-C [SDU Sync to Audio Out Latency - AC13: 48_3_g]	AC 13		48_3_g
GMAP/BGR/MXLT/BV-04-C [SDU Sync to Audio Out Latency - AC13: 48_4_g]	AC 13		48_4_g
GMAP/BGR/MXLT/BV-09-C [SDU Sync to Audio Out Latency - AC14: 48_1_g]	AC 14		48_1_g
GMAP/BGR/MXLT/BV-10-C [SDU Sync to Audio Out Latency - AC14: 48_2_g]	AC 14		48_2_g
GMAP/BGR/MXLT/BV-11-C [SDU Sync to Audio Out Latency - AC14: 48_3_g]	AC 14		48_3_g
GMAP/BGR/MXLT/BV-12-C [SDU Sync to Audio Out Latency - AC14: 48_4_g]	AC 14		48_4_g

Table 4.11: SDU Sync to Audio Out max latency – BGR test cases

- Test Procedure
 1. The Lower Tester broadcasts audio streams in the Audio Configuration and QoS Settings described in [Table 4.11](#). It uses Level A parameters specified in [\[5\] Table 3.22: Recommended LL parameters for Broadcast QoS configuration](#).
 2. The Upper Tester commands the IUT to synchronize to both broadcast audio streams if the IUT is capable of synchronizing to two streams, or to either audio stream if the IUT can synchronize to only a single stream.
 3. The Audio Signal Generator produces one or more audio bursts to the Lower Tester and is detected by the Latency Timer.
 4. Audio produced by the IUT is detected by the Latency Timer that measures the Total System Delay.

- Expected Outcome

Pass verdict

The SDU Sync to Audio Out Latency is 10 ms. Measured latency between 9.8875 ms and 10.1125 ms is acceptable.

4.4.3 Max latency, UGT to UGG

Verify that the UGT or UGG IUT supports a Total System Delay of 100 ms or less in the UGT to UGG direction.

4.4.3.1 Audio In to SDU Sync max latency, UGT to UGG – UGT

- Test Purpose

Verify that the UGT IUT supports the Audio In to SDU Sync Latency of 60 ms in the UGT to UGG direction.
- Reference

[\[5\] 3.6](#)
- Initial Condition
 - The Lower Tester is a UGG.
 - The test system is configured as described in [Section 3.2.1.4, Audio In to SDU Sync Latency test strategy, UGT to UGG, IUT is UGT](#), with the IUT, the Lower Tester, Latency Timer, and Audio Signal Generator. An Upper Tester is also required to configure and command the IUT.
 - The IUT and the Lower Tester are bonded and connected with an ACL connection.

- Test Case Configuration

Test Case	Audio Configuration	Legend	UGG to UGT QoS Setting	UGT to UGG QoS Setting
GMAP/UGT/MXLT/BV-122-C [Audio In to SDU Sync Latency - AC2: 16_1_gs]	AC 2	<-----	N/A	16_1_gs
GMAP/UGT/MXLT/BV-123-C [Audio In to SDU Sync Latency - AC2: 16_2_gs]	AC 2	<-----	N/A	16_2_gs
GMAP/UGT/MXLT/BV-80-C [Audio In to SDU Sync Latency - AC2: 32_1_gs]	AC 2	<-----	N/A	32_1_gs
GMAP/UGT/MXLT/BV-81-C [Audio In to SDU Sync Latency - AC2: 32_2_gs]	AC 2	<-----	N/A	32_2_gs
GMAP/UGT/MXLT/BV-82-C [Audio In to SDU Sync Latency - AC2: 48_1_gs]	AC 2	<-----	N/A	48_1_gs
GMAP/UGT/MXLT/BV-83-C [Audio In to SDU Sync Latency - AC2: 48_2_gs]	AC 2	<-----	N/A	48_2_gs
GMAP/UGT/MXLT/BV-124-C [Audio In to SDU Sync Latency - AC3: 32_1_gr, 16_1_gs]	AC 3	<----->	32_1_gr	16_1_gs
GMAP/UGT/MXLT/BV-125-C [Audio In to SDU Sync Latency - AC3: 32_2_gr, 16_2_gs]	AC 3	<----->	32_2_gr	16_2_gs
GMAP/UGT/MXLT/BV-126-C [Audio In to SDU Sync Latency - AC3: 48_1_gr, 16_1_gs]	AC 3	<----->	48_1_gr	16_1_gs
GMAP/UGT/MXLT/BV-127-C [Audio In to SDU Sync Latency - AC3: 48_2_gr, 16_2_gs]	AC 3	<----->	48_2_gr	16_2_gs
GMAP/UGT/MXLT/BV-84-C [Audio In to SDU Sync Latency - AC3: 32_1_gr, 32_1_gs]	AC 3	<----->	32_1_gr	32_1_gs
GMAP/UGT/MXLT/BV-85-C [Audio In to SDU Sync Latency - AC3: 32_2_gr, 32_2_gs]	AC 3	<----->	32_2_gr	32_2_gs
GMAP/UGT/MXLT/BV-86-C [Audio In to SDU Sync Latency - AC3: 48_1_gr, 32_1_gs]	AC 3	<----->	48_1_gr	32_1_gs
GMAP/UGT/MXLT/BV-87-C [Audio In to SDU Sync Latency - AC3: 48_2_gr, 32_2_gs]	AC 3	<----->	48_2_gr	32_2_gs
GMAP/UGT/MXLT/BV-88-C [Audio In to SDU Sync Latency - AC3: 48_1_gr, 48_1_gs]	AC 3	<----->	48_1_gr	48_1_gs
GMAP/UGT/MXLT/BV-89-C [Audio In to SDU Sync Latency - AC3: 48_2_gr, 48_2_gs]	AC 3	<----->	48_2_gr	48_2_gs
GMAP/UGT/MXLT/BV-90-C [Audio In to SDU Sync Latency - AC3: 48_3_gr, 32_1_gs]	AC 3	<----->	48_3_gr	32_1_gs
GMAP/UGT/MXLT/BV-91-C [Audio In to SDU Sync Latency - AC3: 48_4_gr, 32_2_gs]	AC 3	<----->	48_4_gr	32_2_gs
GMAP/UGT/MXLT/BV-92-C [Audio In to SDU Sync Latency - AC3: 48_3_gr, 48_1_gs]	AC 3	<----->	48_3_gr	48_1_gs
GMAP/UGT/MXLT/BV-93-C [Audio In to SDU Sync Latency - AC3: 48_4_gr, 48_2_gs]	AC 3	<----->	48_4_gr	48_2_gs
GMAP/UGT/MXLT/BV-128-C [Audio In to SDU Sync Latency - AC5: 32_1_gr, 16_1_gs]	AC 5	<----->	32_1_gr	16_1_gs
GMAP/UGT/MXLT/BV-129-C [Audio In to SDU Sync Latency - AC5: 32_2_gr, 16_2_gs]	AC 5	<----->	32_2_gr	16_2_gs
GMAP/UGT/MXLT/BV-130-C [Audio In to SDU Sync Latency - AC5: 48_1_gr, 16_1_gs]	AC 5	<----->	48_1_gr	16_1_gs
GMAP/UGT/MXLT/BV-131-C [Audio In to SDU Sync Latency - AC5: 48_2_gr, 16_2_gs]	AC 5	<----->	48_2_gr	16_2_gs
GMAP/UGT/MXLT/BV-94-C [Audio In to SDU Sync Latency - AC5: 32_1_gr, 32_1_gs]	AC 5	<----->	32_1_gr	32_1_gs



Test Case	Audio Configuration	Legend	UGG to UGT QoS Setting	UGT to UGG QoS Setting
GMAP/UGT/MXLT/BV-95-C [Audio In to SDU Sync Latency - AC5: 32_2_gr, 32_2_gs]	AC 5	<----->	32_2_gr	32_2_gs
GMAP/UGT/MXLT/BV-96-C [Audio In to SDU Sync Latency - AC5: 48_1_gr, 32_1_gs]	AC 5	<----->	48_1_gr	32_1_gs
GMAP/UGT/MXLT/BV-97-C [Audio In to SDU Sync Latency - AC5: 48_2_gr, 32_2_gs]	AC 5	<----->	48_2_gr	32_2_gs
GMAP/UGT/MXLT/BV-98-C [Audio In to SDU Sync Latency - AC5: 48_1_gr, 48_1_gs]	AC 5	<----->	48_1_gr	48_1_gs
GMAP/UGT/MXLT/BV-99-C [Audio In to SDU Sync Latency - AC5: 48_2_gr, 48_2_gs]	AC 5	<----->	48_2_gr	48_2_gs
GMAP/UGT/MXLT/BV-100-C [Audio In to SDU Sync Latency - AC5: 48_3_gr, 32_1_gs]	AC 5	<----->	48_3_gr	32_1_gs
GMAP/UGT/MXLT/BV-101-C [Audio In to SDU Sync Latency - AC5: 48_4_gr, 32_2_gs]	AC 5	<----->	48_4_gr	32_2_gs
GMAP/UGT/MXLT/BV-132-C [Audio In to SDU Sync Latency - AC8i: 32_1_gr, 16_1_gs]	AC 8(i)	-----> <----->	32_1_gr	16_1_gs
GMAP/UGT/MXLT/BV-133-C [Audio In to SDU Sync Latency - AC8i: 32_2_gr, 16_2_gs]	AC 8(i)	-----> <----->	32_2_gr	16_2_gs
GMAP/UGT/MXLT/BV-134-C [Audio In to SDU Sync Latency - AC8i: 48_1_gr, 16_1_gs]	AC 8(i)	-----> <----->	48_1_gr	16_1_gs
GMAP/UGT/MXLT/BV-135-C [Audio In to SDU Sync Latency - AC8i: 48_2_gr, 16_2_gs]	AC 8(i)	-----> <----->	48_2_gr	16_2_gs
GMAP/UGT/MXLT/BV-102-C [Audio In to SDU Sync Latency - AC8i: 32_1_gr, 32_1_gs]	AC 8(i)	-----> <----->	32_1_gr	32_1_gs
GMAP/UGT/MXLT/BV-103-C [Audio In to SDU Sync Latency - AC8i: 32_2_gr, 32_2_gs]	AC 8(i)	-----> <----->	32_2_gr	32_2_gs
GMAP/UGT/MXLT/BV-104-C [Audio In to SDU Sync Latency - AC8i: 48_1_gr, 32_1_gs]	AC 8(i)	-----> <----->	48_1_gr	32_1_gs
GMAP/UGT/MXLT/BV-105-C [Audio In to SDU Sync Latency - AC8i: 48_2_gr, 32_2_gs]	AC 8(i)	-----> <----->	48_2_gr	32_2_gs
GMAP/UGT/MXLT/BV-106-C [Audio In to SDU Sync Latency - AC8i: 48_1_gr, 48_1_gs]	AC 8(i)	-----> <----->	48_1_gr	48_1_gs
GMAP/UGT/MXLT/BV-107-C [Audio In to SDU Sync Latency - AC8i: 48_2_gr, 48_2_gs]	AC 8(i)	-----> <----->	48_2_gr	48_2_gs
GMAP/UGT/MXLT/BV-108-C [Audio In to SDU Sync Latency - AC8i: 48_3_gr, 32_1_gs]	AC 8(i)	-----> <----->	48_3_gr	32_1_gs



Test Case	Audio Configuration	Legend	UGG to UGT QoS Setting	UGT to UGG QoS Setting
GMAP/UGT/MXLT/BV-109-C [Audio In to SDU Sync Latency - AC8i: 48_4_gr, 32_2_gs]	AC 8(i)	-----> <-----	48_4_gr	32_2_gs
GMAP/UGT/MXLT/BV-146-C [Audio In to SDU Sync Latency - AC11i: 32_1_gr, 16_1_gs]	AC 11(i)	<-----> <-----	32_1_gr	16_1_gs
GMAP/UGT/MXLT/BV-147-C [Audio In to SDU Sync Latency - AC11i: 32_2_gr, 16_2_gs]	AC 11(i)	<-----> <-----	32_2_gr	16_2_gs
GMAP/UGT/MXLT/BV-148-C [Audio In to SDU Sync Latency - AC11i: 48_1_gr, 16_1_gs]	AC 11(i)	<-----> <-----	48_1_gr	16_1_gs
GMAP/UGT/MXLT/BV-149-C [Audio In to SDU Sync Latency - AC11i: 48_2_gr, 16_2_gs]	AC 11(i)	<-----> <-----	48_2_gr	16_2_gs
GMAP/UGT/MXLT/BV-150-C [Audio In to SDU Sync Latency - AC11i: 32_1_gr, 32_1_gs]	AC 11(i)	<-----> <-----	32_1_gr	32_1_gs
GMAP/UGT/MXLT/BV-151-C [Audio In to SDU Sync Latency - AC11i: 32_2_gr, 32_2_gs]	AC 11(i)	<-----> <-----	32_2_gr	32_2_gs
GMAP/UGT/MXLT/BV-152-C [Audio In to SDU Sync Latency - AC11i: 48_1_gr, 32_1_gs]	AC 11(i)	<-----> <-----	48_1_gr	32_1_gs
GMAP/UGT/MXLT/BV-153-C [Audio In to SDU Sync Latency - AC11i: 48_2_gr, 32_2_gs]	AC 11(i)	<-----> <-----	48_2_gr	32_2_gs
GMAP/UGT/MXLT/BV-154-C [Audio In to SDU Sync Latency - AC11i: 48_3_gr, 32_1_gs]	AC 11(i)	<-----> <-----	48_3_gr	32_1_gs
GMAP/UGT/MXLT/BV-155-C [Audio In to SDU Sync Latency - AC11i: 48_4_gr, 32_2_gs]	AC 11(i)	<-----> <-----	48_4_gr	32_2_gs

Table 4.12: Audio In to SDU Sync max latency, UGT to UGG – UGG test cases



- Test Procedure
 1. The Lower Tester establishes one or more audio streams with the IUT in the Audio Configuration and QoS setting(s) described in [Table 4.12](#). It uses Level A parameters specified in [\[5\] Table 3.16: Recommended LL parameters for Unicast QoS configurations 8\(i\) and 8\(ii\)](#) and [\[5\] Table 3.17: Recommended LL parameters for Unicast QoS configurations 11\(i\) and 11\(ii\)](#).
 2. The Audio Signal Generator produces one or more audio bursts to the IUT's audio input(s).
 3. The Latency Timer detects the start of the audio sent to the IUT at one of the Audio In inputs.
 4. The IUT sends audio in the established audio stream(s) to the Lower Tester.
 5. The Latency Timer detects the audio at the corresponding Audio Out outputs at the Lower Tester and measures the Total System Delay.

- Expected Outcome

Pass verdict

The Audio In to SDU Sync Latency is 60 ms, with a +/- 62.5 μ s tolerance, plus a +/- 50 μ s tolerance for the calibrated Lower Tester, for a total tolerance of +/- 112.5 μ s.

4.4.3.2 SDU Sync to Audio Out max latency, UGT to UGG – UGG

- Test Purpose

Verify that the UGG IUT supports the SDU Sync to Audio Out maximum latency of 40 ms or less.

- Reference

[\[5\] 3.6](#)

- Initial Condition

- Lower Tester 1 and Lower Tester 2 are UGG devices.
- Lower Tester 1 is the Lower Tester from which the Total System Delay is measured, and in many Audio Configurations, it is the sole Lower Tester.
- If two Acceptors are defined in the Audio Configuration, then Lower Tester 2 is the Lower Tester where Total System Delay is not measured.
- The test system is configured as described in Section [3.2.1.5, SDU Sync to Audio Out Latency test strategy, UGT to UGG, IUT is UGG](#), with the IUT, one or two Lower Testers, Latency Timer, and Audio Signal Generator. An Upper Tester is required to configure and command the IUT.
- The IUT and the Lower Tester are bonded and connected with an ACL connection.

- Test Case Configuration

Test Case	Audio Configuration	Legend	UGG to UGT QoS Setting	UGT to UGG QoS Setting	Lower Tester(s)
GMAP/UGG/MXLT/BV-148-C [SDU Sync to Audio Out Latency - AC2: 16_1_gs]	AC 2	<-----	N/A	16_1_gs	1
GMAP/UGG/MXLT/BV-149-C [SDU Sync to Audio Out Latency - AC2: 16_2_gs]	AC 2	<-----	N/A	16_2_gs	1
GMAP/UGG/MXLT/BV-80-C [SDU Sync to Audio Out Latency - AC2: 32_1_gs]	AC 2	<-----	N/A	32_1_gs	1
GMAP/UGG/MXLT/BV-81-C [SDU Sync to Audio Out Latency - AC2: 32_2_gs]	AC 2	<-----	N/A	32_2_gs	1
GMAP/UGG/MXLT/BV-82-C [SDU Sync to Audio Out Latency - AC2: 48_1_gs]	AC 2	<-----	N/A	48_1_gs	1
GMAP/UGG/MXLT/BV-83-C [SDU Sync to Audio Out Latency - AC2: 48_2_gs]	AC 2	<-----	N/A	48_2_gs	1
GMAP/UGG/MXLT/BV-150-C [SDU Sync to Audio Out Latency - AC3: 32_1_gr, 16_1_gs]	AC 3	<----->	32_1_gr	16_1_gs	1
GMAP/UGG/MXLT/BV-151-C [SDU Sync to Audio Out Latency - AC3: 32_2_gr, 16_2_gs]	AC 3	<----->	32_2_gr	16_2_gs	1
GMAP/UGG/MXLT/BV-152-C [SDU Sync to Audio Out Latency - AC3: 48_1_gr, 16_1_gs]	AC 3	<----->	48_1_gr	16_1_gs	1
GMAP/UGG/MXLT/BV-153-C [SDU Sync to Audio Out Latency - AC3: 48_2_gr, 16_2_gs]	AC 3	<----->	48_2_gr	16_2_gs	1
GMAP/UGG/MXLT/BV-84-C [SDU Sync to Audio Out Latency - AC3: 32_1_gr, 32_1_gs]	AC 3	<----->	32_1_gr	32_1_gs	1
GMAP/UGG/MXLT/BV-85-C [SDU Sync to Audio Out Latency - AC3: 32_2_gr, 32_2_gs]	AC 3	<----->	32_2_gr	32_2_gs	1
GMAP/UGG/MXLT/BV-86-C [SDU Sync to Audio Out Latency - AC3: 48_1_gr, 32_1_gs]	AC 3	<----->	48_1_gr	32_1_gs	1
GMAP/UGG/MXLT/BV-87-C [SDU Sync to Audio Out Latency - AC3: 48_2_gr, 32_2_gs]	AC 3	<----->	48_2_gr	32_2_gs	1
GMAP/UGG/MXLT/BV-88-C [SDU Sync to Audio Out Latency - AC3: 48_1_gr, 48_1_gs]	AC 3	<----->	48_1_gr	48_1_gs	1



Test Case	Audio Configuration	Legend	UGG to UGT QoS Setting	UGT to UGG QoS Setting	Lower Tester(s)
GMAP/UGG/MXLT/BV-89-C [SDU Sync to Audio Out Latency - AC3: 48_2_gr, 48_2_gs]	AC 3	<----->	48_2_gr	48_2_gs	1
GMAP/UGG/MXLT/BV-90-C [SDU Sync to Audio Out Latency - AC3: 48_3_gr, 32_1_gs]	AC 3	<----->	48_3_gr	32_1_gs	1
GMAP/UGG/MXLT/BV-91-C [SDU Sync to Audio Out Latency - AC3: 48_4_gr, 32_2_gs]	AC 3	<----->	48_4_gr	32_2_gs	1
GMAP/UGG/MXLT/BV-92-C [SDU Sync to Audio Out Latency - AC3: 48_3_gr, 48_1_gs]	AC 3	<----->	48_3_gr	48_1_gs	1
GMAP/UGG/MXLT/BV-93-C [SDU Sync to Audio Out Latency - AC3: 48_4_gr, 48_2_gs]	AC 3	<----->	48_4_gr	48_2_gs	1
GMAP/UGG/MXLT/BV-154-C [SDU Sync to Audio Out Latency - AC5: 32_1_gr, 16_1_gs]	AC 5	<----->	32_1_gr	16_1_gs	1
GMAP/UGG/MXLT/BV-155-C [SDU Sync to Audio Out Latency - AC5: 32_2_gr, 16_2_gs]	AC 5	<----->	32_2_gr	16_2_gs	1
GMAP/UGG/MXLT/BV-156-C [SDU Sync to Audio Out Latency - AC5: 48_1_gr, 16_1_gs]	AC 5	<----->	48_1_gr	16_1_gs	1
GMAP/UGG/MXLT/BV-157-C [SDU Sync to Audio Out Latency - AC5: 48_2_gr, 16_2_gs]	AC 5	<----->	48_2_gr	16_2_gs	1
GMAP/UGG/MXLT/BV-94-C [SDU Sync to Audio Out Latency - AC5: 32_1_gr, 32_1_gs]	AC 5	<----->	32_1_gr	32_1_gs	1
GMAP/UGG/MXLT/BV-95-C [SDU Sync to Audio Out Latency - AC5: 32_2_gr, 32_2_gs]	AC 5	<----->	32_2_gr	32_2_gs	1
GMAP/UGG/MXLT/BV-96-C [SDU Sync to Audio Out Latency - AC5: 48_1_gr, 32_1_gs]	AC 5	<----->	48_1_gr	32_1_gs	1
GMAP/UGG/MXLT/BV-97-C [SDU Sync to Audio Out Latency - AC5: 48_2_gr, 32_2_gs]	AC 5	<----->	48_2_gr	32_2_gs	1
GMAP/UGG/MXLT/BV-98-C [SDU Sync to Audio Out Latency - AC5: 48_1_gr, 48_1_gs]	AC 5	<----->	48_1_gr	48_1_gs	1
GMAP/UGG/MXLT/BV-99-C [SDU Sync to Audio Out Latency - AC5: 48_2_gr, 48_2_gs]	AC 5	<----->	48_2_gr	48_2_gs	1



Test Case	Audio Configuration	Legend	UGG to UGT QoS Setting	UGT to UGG QoS Setting	Lower Tester(s)
GMAP/UGG/MXLT/BV-100-C [SDU Sync to Audio Out Latency - AC5: 48_3_gr, 32_1_gs]	AC 5	<----->	48_3_gr	32_1_gs	1
GMAP/UGG/MXLT/BV-101-C [SDU Sync to Audio Out Latency - AC5: 48_4_gr, 32_2_gs]	AC 5	<----->	48_4_gr	32_2_gs	1
GMAP/UGG/MXLT/BV-158-C [SDU Sync to Audio Out Latency - AC7(ii): 32_1_gr, 16_1_gs]	AC 7(ii)	<----- ----->	32_1_gr	16_1_gs	2
GMAP/UGG/MXLT/BV-159-C [SDU Sync to Audio Out Latency - AC7(ii): 32_2_gr, 16_2_gs]	AC 7(ii)	<----- ----->	32_2_gr	16_2_gs	2
GMAP/UGG/MXLT/BV-160-C [SDU Sync to Audio Out Latency - AC7(ii): 48_1_gr, 16_1_gs]	AC 7(ii)	<----- ----->	48_1_gr	16_1_gs	2
GMAP/UGG/MXLT/BV-161-C [SDU Sync to Audio Out Latency - AC7(ii): 48_2_gr, 16_2_gs]	AC 7(ii)	<----- ----->	48_2_gr	16_2_gs	2
GMAP/UGG/MXLT/BV-102-C [SDU Sync to Audio Out Latency - AC7(ii): 32_1_gr, 32_1_gs]	AC 7(ii)	<----- ----->	32_1_gr	32_1_gs	2
GMAP/UGG/MXLT/BV-103-C [SDU Sync to Audio Out Latency - AC7(ii): 32_2_gr, 32_2_gs]	AC 7(ii)	<----- ----->	32_2_gr	32_2_gs	2
GMAP/UGG/MXLT/BV-104-C [SDU Sync to Audio Out Latency - AC7(ii): 48_1_gr, 32_1_gs]	AC 7(ii)	<----- ----->	48_1_gr	32_1_gs	2
GMAP/UGG/MXLT/BV-105-C [SDU Sync to Audio Out Latency - AC7(ii): 48_2_gr, 32_2_gs]	AC 7(ii)	<----- ----->	48_2_gr	32_2_gs	2
GMAP/UGG/MXLT/BV-106-C [SDU Sync to Audio Out Latency - AC7(ii): 48_1_gr, 48_1_gs]	AC 7(ii)	<----- ----->	48_1_gr	48_1_gs	2
GMAP/UGG/MXLT/BV-107-C [SDU Sync to Audio Out Latency - AC7(ii): 48_2_gr, 48_2_gs]	AC 7(ii)	<----- ----->	48_2_gr	48_2_gs	2
GMAP/UGG/MXLT/BV-108-C [SDU Sync to Audio Out Latency - AC7(ii): 48_3_gr, 32_1_gs]	AC 7(ii)	<----- ----->	48_3_gr	32_1_gs	2
GMAP/UGG/MXLT/BV-109-C [SDU Sync to Audio Out Latency - AC7(ii): 48_4_gr, 32_2_gs]	AC 7(ii)	<----- ----->	48_4_gr	32_2_gs	2
GMAP/UGG/MXLT/BV-110-C [SDU Sync to Audio Out Latency - AC7(ii): 48_3_gr, 48_1_gs]	AC 7(ii)	<----- ----->	48_3_gr	48_1_gs	2

Test Case	Audio Configuration	Legend	UGG to UGT QoS Setting	UGT to UGG QoS Setting	Lower Tester(s)
GMAP/UGG/MXLT/BV-111-C [SDU Sync to Audio Out Latency - AC7(ii): 48_4_gr, 48_2_gs]	AC 7(ii)	<----- ----->	48_4_gr	48_2_gs	2
GMAP/UGG/MXLT/BV-162-C [SDU Sync to Audio Out Latency - AC8i: 32_1_gr, 16_1_gs]	AC 8(i)	-----> <----->	32_1_gr	16_1_gs	1
GMAP/UGG/MXLT/BV-163-C [SDU Sync to Audio Out Latency - AC8i: 32_2_gr, 16_2_gs]	AC 8(i)	-----> <----->	32_2_gr	16_2_gs	1
GMAP/UGG/MXLT/BV-164-C [SDU Sync to Audio Out Latency - AC8i: 48_1_gr, 16_1_gs]	AC 8(i)	-----> <----->	48_1_gr	16_1_gs	1
GMAP/UGG/MXLT/BV-165-C [SDU Sync to Audio Out Latency - AC8i: 48_2_gr, 16_2_gs]	AC 8(i)	-----> <----->	48_2_gr	16_2_gs	1
GMAP/UGG/MXLT/BV-112-C [SDU Sync to Audio Out Latency - AC8i: 32_1_gr, 32_1_gs]	AC 8(i)	-----> <----->	32_1_gr	32_1_gs	1
GMAP/UGG/MXLT/BV-113-C [SDU Sync to Audio Out Latency - AC8i: 32_2_gr, 32_2_gs]	AC 8(i)	-----> <----->	32_2_gr	32_2_gs	1
GMAP/UGG/MXLT/BV-114-C [SDU Sync to Audio Out Latency - AC8i: 48_1_gr, 32_1_gs]	AC 8(i)	-----> <----->	48_1_gr	32_1_gs	1
GMAP/UGG/MXLT/BV-115-C [SDU Sync to Audio Out Latency - AC8i: 48_2_gr, 32_2_gs]	AC 8(i)	-----> <----->	48_2_gr	32_2_gs	1
GMAP/UGG/MXLT/BV-116-C [SDU Sync to Audio Out Latency - AC8i: 48_1_gr, 48_1_gs]	AC 8(i)	-----> <----->	48_1_gr	48_1_gs	1
GMAP/UGG/MXLT/BV-117-C [SDU Sync to Audio Out Latency - AC8i: 48_2_gr, 48_2_gs]	AC 8(i)	-----> <----->	48_2_gr	48_2_gs	1
GMAP/UGG/MXLT/BV-118-C [SDU Sync to Audio Out Latency - AC8i: 48_3_gr, 32_1_gs]	AC 8(i)	-----> <----->	48_3_gr	32_1_gs	1
GMAP/UGG/MXLT/BV-119-C [SDU Sync to Audio Out Latency - AC8i: 48_4_gr, 32_2_gs]	AC 8(i)	-----> <----->	48_4_gr	32_2_gs	1
GMAP/UGG/MXLT/BV-166-C [SDU Sync to Audio Out Latency - AC8ii: 32_1_gr, 16_1_gs]	AC 8(ii)	-----> <----->	32_1_gr	16_1_gs	2
GMAP/UGG/MXLT/BV-167-C [SDU Sync to Audio Out Latency - AC8ii: 32_2_gr, 16_2_gs]	AC 8(ii)	-----> <----->	32_2_gr	16_2_gs	2



Test Case	Audio Configuration	Legend	UGG to UGT QoS Setting	UGT to UGG QoS Setting	Lower Tester(s)
GMAP/UGG/MXLT/BV-168-C [SDU Sync to Audio Out Latency - AC8ii: 48_1_gr, 16_1_gs]	AC 8(ii)	-----> <-----	48_1_gr	16_1_gs	2
GMAP/UGG/MXLT/BV-169-C [SDU Sync to Audio Out Latency - AC8ii: 48_2_gr, 16_2_gs]	AC 8(ii)	-----> <-----	48_2_gr	16_2_gs	2
GMAP/UGG/MXLT/BV-120-C [SDU Sync to Audio Out Latency - AC8ii: 32_1_gr, 32_1_gs]	AC 8(ii)	-----> <-----	32_1_gr	32_1_gs	2
GMAP/UGG/MXLT/BV-121-C [SDU Sync to Audio Out Latency - AC8ii: 32_2_gr, 32_2_gs]	AC 8(ii)	-----> <-----	32_2_gr	32_2_gs	2
GMAP/UGG/MXLT/BV-122-C [SDU Sync to Audio Out Latency - AC8ii: 48_1_gr, 32_1_gs]	AC 8(ii)	-----> <-----	48_1_gr	32_1_gs	2
GMAP/UGG/MXLT/BV-123-C [SDU Sync to Audio Out Latency - AC8ii: 48_2_gr, 32_2_gs]	AC 8(ii)	-----> <-----	48_2_gr	32_2_gs	2
GMAP/UGG/MXLT/BV-124-C [SDU Sync to Audio Out Latency - AC8ii: 48_1_gr, 48_1_gs]	AC 8(ii)	-----> <-----	48_1_gr	48_1_gs	2
GMAP/UGG/MXLT/BV-125-C [SDU Sync to Audio Out Latency - AC8ii: 48_2_gr, 48_2_gs]	AC 8(ii)	-----> <-----	48_2_gr	48_2_gs	2
GMAP/UGG/MXLT/BV-126-C [SDU Sync to Audio Out Latency - AC8ii: 48_3_gr, 32_1_gs]	AC 8(ii)	-----> <-----	48_3_gr	32_1_gs	2
GMAP/UGG/MXLT/BV-127-C [SDU Sync to Audio Out Latency - AC8ii: 48_4_gr, 32_2_gs]	AC 8(ii)	-----> <-----	48_4_gr	32_2_gs	2
GMAP/UGG/MXLT/BV-190-C [SDU Sync to Audio Out Latency - AC11i: 32_1_gr, 16_1_gs]	AC 11(i)	<-----> <----->	32_1_gr	16_1_gs	1
GMAP/UGG/MXLT/BV-191-C [SDU Sync to Audio Out Latency - AC11i: 32_2_gr, 16_2_gs]	AC 11(i)	<-----> <----->	32_2_gr	16_2_gs	1
GMAP/UGG/MXLT/BV-192-C [SDU Sync to Audio Out Latency - AC11i: 48_1_gr, 16_1_gs]	AC 11(i)	<-----> <----->	48_1_gr	16_1_gs	1
GMAP/UGG/MXLT/BV-193-C [SDU Sync to Audio Out Latency - AC11i: 48_2_gr, 16_2_gs]	AC 11(i)	<-----> <----->	48_2_gr	16_2_gs	1
GMAP/UGG/MXLT/BV-194-C [SDU Sync to Audio Out Latency - AC11i: 32_1_gr, 32_1_gs]	AC 11(i)	<-----> <----->	32_1_gr	32_1_gs	1

Test Case	Audio Configuration	Legend	UGG to UGT QoS Setting	UGT to UGG QoS Setting	Lower Tester(s)
GMAP/UGG/MXLT/BV-195-C [SDU Sync to Audio Out Latency - AC11i: 32_2_gr, 32_2_gs]	AC 11(i)	<-----> <----->	32_2_gr	32_2_gs	1
GMAP/UGG/MXLT/BV-196-C [SDU Sync to Audio Out Latency - AC11i: 48_1_gr, 32_1_gs]	AC 11(i)	<-----> <----->	48_1_gr	32_1_gs	1
GMAP/UGG/MXLT/BV-197-C [SDU Sync to Audio Out Latency - AC11i: 48_2_gr, 32_2_gs]	AC 11(i)	<-----> <----->	48_2_gr	32_2_gs	1
GMAP/UGG/MXLT/BV-198-C [SDU Sync to Audio Out Latency - AC11i: 48_3_gr, 32_1_gs]	AC 11(i)	<-----> <----->	48_3_gr	32_1_gs	1
GMAP/UGG/MXLT/BV-199-C [SDU Sync to Audio Out Latency - AC11i: 48_4_gr, 32_2_gs]	AC 11(i)	<-----> <----->	48_4_gr	32_2_gs	1
GMAP/UGG/MXLT/BV-200-C [SDU Sync to Audio Out Latency - AC11ii: 32_1_gr, 16_1_gs]	AC 11(ii)	<-----> <----->	32_1_gr	16_1_gs	2
GMAP/UGG/MXLT/BV-201-C [SDU Sync to Audio Out Latency - AC11ii: 32_2_gr, 16_2_gs]	AC 11(ii)	<-----> <----->	32_2_gr	16_2_gs	2
GMAP/UGG/MXLT/BV-202-C [SDU Sync to Audio Out Latency - AC11ii: 48_1_gr, 16_1_gs]	AC 11(ii)	<-----> <----->	48_1_gr	16_1_gs	2
GMAP/UGG/MXLT/BV-203-C [SDU Sync to Audio Out Latency - AC11ii: 48_2_gr, 16_2_gs]	AC 11(ii)	<-----> <----->	48_2_gr	16_2_gs	2
GMAP/UGG/MXLT/BV-204-C [SDU Sync to Audio Out Latency - AC11ii: 32_1_gr, 32_1_gs]	AC 11(ii)	<-----> <----->	32_1_gr	32_1_gs	2
GMAP/UGG/MXLT/BV-205-C [SDU Sync to Audio Out Latency - AC11ii: 32_2_gr, 32_2_gs]	AC 11(ii)	<-----> <----->	32_2_gr	32_2_gs	2
GMAP/UGG/MXLT/BV-206-C [SDU Sync to Audio Out Latency - AC11ii: 48_1_gr, 32_1_gs]	AC 11(ii)	<-----> <----->	48_1_gr	32_1_gs	2
GMAP/UGG/MXLT/BV-207-C [SDU Sync to Audio Out Latency - AC11ii: 48_2_gr, 32_2_gs]	AC 11(ii)	<-----> <----->	48_2_gr	32_2_gs	2
GMAP/UGG/MXLT/BV-208-C [SDU Sync to Audio Out Latency - AC11ii: 48_3_gr, 32_1_gs]	AC 11(ii)	<-----> <----->	48_3_gr	32_1_gs	2
GMAP/UGG/MXLT/BV-209-C [SDU Sync to Audio Out Latency - AC11ii: 48_4_gr, 32_2_gs]	AC 11(ii)	<-----> <----->	48_4_gr	32_2_gs	2

Table 4.13: SDU Sync to Audio Out max latency, UGT to UGG – UGG test cases



- Test Procedure
 1. The Upper Tester commands the IUT to establish one or more audio streams with the Lower Tester(s) in the Audio Configuration and QoS Settings described in [Table 4.13](#). The IUT uses Level A parameters specified in [\[5\] Table 3.16: Recommended LL parameters for Unicast QoS configurations 8\(i\) and 8\(ii\)](#) and [\[5\] Table 3.17: Recommended LL parameters for Unicast QoS configurations 11\(i\) and 11\(ii\)](#).
 2. The Audio Signal Generator produces one or more audio bursts to Lower Tester 1 and is detected by the Latency Timer.
 3. The IUT receives audio in the established audio stream(s) from the Lower Tester(s).
 4. The audio produced by the IUT is detected by the Latency Timer that measures the Total System Delay.

- Expected Outcome

Pass verdict

The SDU Sync to Audio Out Latency is no greater than 40 ms, with a +/- 100 μ s tolerance, plus a +/- 50 μ s tolerance for the Calibrated Lower Tester, for a total tolerance of +/- 150 μ s.

4.4.4 UGG Max Total Latency in both directions

- Test Purpose

Verify that the UGG IUT supports a total latency of 70 ms or less when audio is sent from the UGT to the UGG, then echoed back to the UGT.

- Reference

[\[5\] 3.6](#)

- Initial Condition

- The Lower Tester is a UGT.
- The test system is configured as described in [Section 3.2.1.7, Audio loopback for UGG IUTs without external Audio In and/or Audio Out](#).
- The IUT and the Lower Tester(s) are bonded and connected with an ACL connection.
- The IUT has discovered all relevant services and characteristics of the Lower Tester(s).

- Test Case Configuration

Test Case	Audio Configuration	Legend	UGG to UGT QoS Setting	UGT to UGG QoS Setting	Lower Tester(s)
GMAP/UGG/MXLT/BV-220-C [UGG Combined Latencies - AC3: 32_1_gr, 16_1_gs]	AC 3	<----->	32_1_gr	16_1_gs	1
GMAP/UGG/MXLT/BV-221-C [UGG Combined Latencies - AC3: 32_2_gr, 16_2_gs]	AC 3	<----->	32_2_gr	16_2_gs	1
GMAP/UGG/MXLT/BV-222-C [UGG Combined Latencies - AC3: 48_1_gr, 16_1_gs]	AC 3	<----->	48_1_gr	16_1_gs	1
GMAP/UGG/MXLT/BV-223-C [UGG Combined Latencies - AC3: 48_2_gr, 16_2_gs]	AC 3	<----->	48_2_gr	16_2_gs	1
GMAP/UGG/MXLT/BV-224-C [UGG Combined Latencies - AC3: 32_1_gr, 32_1_gs]	AC 3	<----->	32_1_gr	32_1_gs	1
GMAP/UGG/MXLT/BV-225-C [UGG Combined Latencies - AC3: 32_2_gr, 32_2_gs]	AC 3	<----->	32_2_gr	32_2_gs	1
GMAP/UGG/MXLT/BV-226-C [UGG Combined Latencies - AC3: 48_1_gr, 32_1_gs]	AC 3	<----->	48_1_gr	32_1_gs	1
GMAP/UGG/MXLT/BV-227-C [UGG Combined Latencies - AC3: 48_2_gr, 32_2_gs]	AC 3	<----->	48_2_gr	32_2_gs	1
GMAP/UGG/MXLT/BV-228-C [UGG Combined Latencies - AC3: 48_1_gr, 48_1_gs]	AC 3	<----->	48_1_gr	48_1_gs	1
GMAP/UGG/MXLT/BV-229-C [UGG Combined Latencies - AC3: 48_2_gr, 48_2_gs]	AC 3	<----->	48_2_gr	48_2_gs	1
GMAP/UGG/MXLT/BV-230-C [UGG Combined Latencies - AC3: 48_3_gr, 32_1_gs]	AC 3	<----->	48_3_gr	32_1_gs	1
GMAP/UGG/MXLT/BV-231-C [UGG Combined Latencies - AC3: 48_4_gr, 32_2_gs]	AC 3	<----->	48_4_gr	32_2_gs	1
GMAP/UGG/MXLT/BV-232-C [UGG Combined Latencies - AC3: 48_3_gr, 48_1_gs]	AC 3	<----->	48_3_gr	48_1_gs	1
GMAP/UGG/MXLT/BV-233-C [UGG Combined Latencies - AC3: 48_4_gr, 48_2_gs]	AC 3	<----->	48_4_gr	48_2_gs	1
GMAP/UGG/MXLT/BV-234-C [UGG Combined Latencies - AC5: 32_1_gr, 16_1_gs]	AC 5	<----->	32_1_gr	16_1_gs	1



Test Case	Audio Configuration	Legend	UGG to UGT QoS Setting	UGT to UGG QoS Setting	Lower Tester(s)
GMAP/UGG/MXLT/BV-235-C [UGG Combined Latencies - AC5: 32_2_gr, 16_2_gs]	AC 5	<----->	32_2_gr	16_2_gs	1
GMAP/UGG/MXLT/BV-236-C [UGG Combined Latencies - AC5: 48_1_gr, 16_1_gs]	AC 5	<----->	48_1_gr	16_1_gs	1
GMAP/UGG/MXLT/BV-237-C [UGG Combined Latencies - AC5: 48_2_gr, 16_2_gs]	AC 5	<----->	48_2_gr	16_2_gs	1
GMAP/UGG/MXLT/BV-238-C [UGG Combined Latencies - AC5: 32_1_gr, 32_1_gs]	AC 5	<----->	32_1_gr	32_1_gs	1
GMAP/UGG/MXLT/BV-239-C [UGG Combined Latencies - AC5: 32_2_gr, 32_2_gs]	AC 5	<----->	32_2_gr	32_2_gs	1
GMAP/UGG/MXLT/BV-240-C [UGG Combined Latencies - AC5: 48_1_gr, 32_1_gs]	AC 5	<----->	48_1_gr	32_1_gs	1
GMAP/UGG/MXLT/BV-241-C [UGG Combined Latencies - AC5: 48_2_gr, 32_2_gs]	AC 5	<----->	48_2_gr	32_2_gs	1
GMAP/UGG/MXLT/BV-242-C [UGG Combined Latencies - AC5: 48_1_gr, 48_1_gs]	AC 5	<----->	48_1_gr	48_1_gs	1
GMAP/UGG/MXLT/BV-243-C [UGG Combined Latencies - AC5: 48_2_gr, 48_2_gs]	AC 5	<----->	48_2_gr	48_2_gs	1
GMAP/UGG/MXLT/BV-244-C [UGG Combined Latencies - AC5: 48_3_gr, 32_1_gs]	AC 5	<----->	48_3_gr	32_1_gs	1
GMAP/UGG/MXLT/BV-245-C [UGG Combined Latencies - AC5: 48_4_gr, 32_2_gs]	AC 5	<----->	48_4_gr	32_2_gs	1
GMAP/UGG/MXLT/BV-246-C [UGG Combined Latencies - AC7ii: 32_1_gr, 16_1_gs]	AC 7(ii)	-----> <-----	32_1_gr	16_1_gs	2
GMAP/UGG/MXLT/BV-247-C [UGG Combined Latencies - AC7ii: 32_2_gr, 16_2_gs]	AC 7(ii)	-----> <-----	32_2_gr	16_2_gs	2
GMAP/UGG/MXLT/BV-248-C [UGG Combined Latencies - AC7ii: 48_1_gr, 16_1_gs]	AC 7(ii)	-----> <-----	48_1_gr	16_1_gs	2
GMAP/UGG/MXLT/BV-249-C [UGG Combined Latencies - AC7ii: 48_2_gr, 16_2_gs]	AC 7(ii)	-----> <-----	48_2_gr	16_2_gs	2



Test Case	Audio Configuration	Legend	UGG to UGT QoS Setting	UGT to UGG QoS Setting	Lower Tester(s)
GMAP/UGG/MXLT/BV-250-C [UGG Combined Latencies - AC7ii: 32_1_gr, 32_1_gs]	AC 7(ii)	-----> <-----	32_1_gr	32_1_gs	2
GMAP/UGG/MXLT/BV-251-C [UGG Combined Latencies - AC7ii: 32_2_gr, 32_2_gs]	AC 7(ii)	-----> <-----	32_2_gr	32_2_gs	2
GMAP/UGG/MXLT/BV-252-C [UGG Combined Latencies - AC7ii: 48_1_gr, 32_1_gs]	AC 7(ii)	-----> <-----	48_1_gr	32_1_gs	2
GMAP/UGG/MXLT/BV-253-C [UGG Combined Latencies - AC7ii: 48_2_gr, 32_2_gs]	AC 7(ii)	-----> <-----	48_2_gr	32_2_gs	2
GMAP/UGG/MXLT/BV-254-C [UGG Combined Latencies - AC7ii: 48_1_gr, 48_1_gs]	AC 7(ii)	-----> <-----	48_1_gr	48_1_gs	2
GMAP/UGG/MXLT/BV-255-C [UGG Combined Latencies - AC7ii: 48_2_gr, 48_2_gs]	AC 7(ii)	-----> <-----	48_2_gr	48_2_gs	2
GMAP/UGG/MXLT/BV-256-C [UGG Combined Latencies - AC7ii: 48_3_gr, 32_1_gs]	AC 7(ii)	-----> <-----	48_3_gr	32_1_gs	2
GMAP/UGG/MXLT/BV-257-C [UGG Combined Latencies - AC7ii: 48_4_gr, 32_2_gs]	AC 7(ii)	-----> <-----	48_4_gr	32_2_gs	2
GMAP/UGG/MXLT/BV-258-C [UGG Combined Latencies - AC7ii: 48_3_gr, 48_1_gs]	AC 7(ii)	-----> <-----	48_3_gr	48_1_gs	2
GMAP/UGG/MXLT/BV-259-C [UGG Combined Latencies - AC7ii: 48_4_gr, 48_2_gs]	AC 7(ii)	-----> <-----	48_4_gr	48_2_gs	2
GMAP/UGG/MXLT/BV-260-C [UGG Combined Latencies - AC8i: 32_1_gr, 16_1_gs]	AC 8(i)	-----> <----->	32_1_gr	16_1_gs	1
GMAP/UGG/MXLT/BV-261-C [UGG Combined Latencies - AC8i: 32_2_gr, 16_2_gs]	AC 8(i)	-----> <----->	32_2_gr	16_2_gs	1
GMAP/UGG/MXLT/BV-262-C [UGG Combined Latencies - AC8i: 48_1_gr, 16_1_gs]	AC 8(i)	-----> <----->	48_1_gr	16_1_gs	1
GMAP/UGG/MXLT/BV-263-C [UGG Combined Latencies - AC8i: 48_2_gr, 16_2_gs]	AC 8(i)	-----> <----->	48_2_gr	16_2_gs	1



Test Case	Audio Configuration	Legend	UGG to UGT QoS Setting	UGT to UGG QoS Setting	Lower Tester(s)
GMAP/UGG/MXLT/BV-264-C [UGG Combined Latencies - AC8i: 32_1_gr, 32_1_gs]	AC 8(i)	-----> <-----	32_1_gr	32_1_gs	1
GMAP/UGG/MXLT/BV-265-C [UGG Combined Latencies - AC8i: 32_2_gr, 32_2_gs]	AC 8(i)	-----> <-----	32_2_gr	32_2_gs	1
GMAP/UGG/MXLT/BV-266-C [UGG Combined Latencies - AC8i: 48_1_gr, 32_1_gs]	AC 8(i)	-----> <-----	48_1_gr	32_1_gs	1
GMAP/UGG/MXLT/BV-267-C [UGG Combined Latencies - AC8i: 48_2_gr, 32_2_gs]	AC 8(i)	-----> <-----	48_2_gr	32_2_gs	1
GMAP/UGG/MXLT/BV-268-C [UGG Combined Latencies - AC8i: 48_1_gr, 48_1_gs]	AC 8(i)	-----> <-----	48_1_gr	48_1_gs	1
GMAP/UGG/MXLT/BV-269-C [UGG Combined Latencies - AC8i: 48_2_gr, 48_2_gs]	AC 8(i)	-----> <-----	48_2_gr	48_2_gs	1
GMAP/UGG/MXLT/BV-270-C [UGG Combined Latencies - AC8i: 48_3_gr, 32_1_gs]	AC 8(i)	-----> <-----	48_3_gr	32_1_gs	1
GMAP/UGG/MXLT/BV-271-C [UGG Combined Latencies - AC8i: 48_4_gr, 32_2_gs]	AC 8(i)	-----> <-----	48_4_gr	32_2_gs	1
GMAP/UGG/MXLT/BV-272-C [UGG Combined Latencies - AC8ii: 32_1_gr, 16_1_gs]	AC 8(ii)	-----> <-----	32_1_gr	16_1_gs	2
GMAP/UGG/MXLT/BV-273-C [UGG Combined Latencies - AC8ii: 32_2_gr, 16_2_gs]	AC 8(ii)	-----> <-----	32_2_gr	16_2_gs	2
GMAP/UGG/MXLT/BV-274-C [UGG Combined Latencies - AC8ii: 48_1_gr, 16_1_gs]	AC 8(ii)	-----> <-----	48_1_gr	16_1_gs	2
GMAP/UGG/MXLT/BV-275-C [UGG Combined Latencies - AC8ii: 48_2_gr, 16_2_gs]	AC 8(ii)	-----> <-----	48_2_gr	16_2_gs	2
GMAP/UGG/MXLT/BV-276-C [UGG Combined Latencies - AC8ii: 32_1_gr, 32_1_gs]	AC 8(ii)	-----> <-----	32_1_gr	32_1_gs	2
GMAP/UGG/MXLT/BV-277-C [UGG Combined Latencies - AC8ii: 32_2_gr, 32_2_gs]	AC 8(ii)	-----> <-----	32_2_gr	32_2_gs	2

Test Case	Audio Configuration	Legend	UGG to UGT QoS Setting	UGT to UGG QoS Setting	Lower Tester(s)
GMAP/UGG/MXLT/BV-278-C [UGG Combined Latencies - AC8ii: 48_1_gr, 32_1_gs]	AC 8(ii)	-----> <-----	48_1_gr	32_1_gs	2
GMAP/UGG/MXLT/BV-279-C [UGG Combined Latencies - AC8ii: 48_2_gr, 32_2_gs]	AC 8(ii)	-----> <-----	48_2_gr	32_2_gs	2
GMAP/UGG/MXLT/BV-280-C [UGG Combined Latencies - AC8ii: 48_1_gr, 48_1_gs]	AC 8(ii)	-----> <-----	48_1_gr	48_1_gs	2
GMAP/UGG/MXLT/BV-281-C [UGG Combined Latencies - AC8ii: 48_2_gr, 48_2_gs]	AC 8(ii)	-----> <-----	48_2_gr	48_2_gs	2
GMAP/UGG/MXLT/BV-282-C [UGG Combined Latencies - AC8ii: 48_3_gr, 32_1_gs]	AC 8(ii)	-----> <-----	48_3_gr	32_1_gs	2
GMAP/UGG/MXLT/BV-283-C [UGG Combined Latencies - AC8ii: 48_4_gr, 32_2_gs]	AC 8(ii)	-----> <-----	48_4_gr	32_2_gs	2
GMAP/UGG/MXLT/BV-284-C [UGG Combined Latencies - AC11i: 32_1_gr, 16_1_gs]	AC 11(i)	<-----> <----->	32_1_gr	16_1_gs	1
GMAP/UGG/MXLT/BV-285-C [UGG Combined Latencies - AC11i: 32_2_gr, 16_2_gs]	AC 11(i)	<-----> <----->	32_2_gr	16_2_gs	1
GMAP/UGG/MXLT/BV-286-C [UGG Combined Latencies - AC11i: 48_1_gr, 16_1_gs]	AC 11(i)	<-----> <----->	48_1_gr	16_1_gs	1
GMAP/UGG/MXLT/BV-287-C [UGG Combined Latencies - AC11i: 48_2_gr, 16_2_gs]	AC 11(i)	<-----> <----->	48_2_gr	16_2_gs	1
GMAP/UGG/MXLT/BV-288-C [UGG Combined Latencies - AC11i: 32_1_gr, 32_1_gs]	AC 11(i)	<-----> <----->	32_1_gr	32_1_gs	1
GMAP/UGG/MXLT/BV-289-C [UGG Combined Latencies - AC11i: 32_2_gr, 32_2_gs]	AC 11(i)	<-----> <----->	32_2_gr	32_2_gs	1
GMAP/UGG/MXLT/BV-290-C [UGG Combined Latencies - AC11i: 48_1_gr, 32_1_gs]	AC 11(i)	<-----> <----->	48_1_gr	32_1_gs	1
GMAP/UGG/MXLT/BV-291-C [UGG Combined Latencies - AC11i: 48_2_gr, 32_2_gs]	AC 11(i)	<-----> <----->	48_2_gr	32_2_gs	1
GMAP/UGG/MXLT/BV-292-C [UGG Combined Latencies - AC11i: 48_3_gr, 32_1_gs]	AC 11(i)	<-----> <----->	48_3_gr	32_1_gs	1



Test Case	Audio Configuration	Legend	UGG to UGT QoS Setting	UGT to UGG QoS Setting	Lower Tester(s)
GMAP/UGG/MXLT/BV-293-C [UGG Combined Latencies - AC11i: 48_4_gr, 32_2_gs]	AC 11(i)	<-----> <----->	48_4_gr	32_2_gs	1
GMAP/UGG/MXLT/BV-294-C [UGG Combined Latencies - AC11ii: 32_1_gr, 16_1_gs]	AC 11(ii)	<-----> <----->	32_1_gr	16_1_gs	2
GMAP/UGG/MXLT/BV-295-C [UGG Combined Latencies - AC11ii: 32_2_gr, 16_2_gs]	AC 11(ii)	<-----> <----->	32_2_gr	16_2_gs	2
GMAP/UGG/MXLT/BV-296-C [UGG Combined Latencies - AC11ii: 48_1_gr, 16_1_gs]	AC 11(ii)	<-----> <----->	48_1_gr	16_1_gs	2
GMAP/UGG/MXLT/BV-297-C [UGG Combined Latencies - AC11ii: 48_2_gr, 16_2_gs]	AC 11(ii)	<-----> <----->	48_2_gr	16_2_gs	2
GMAP/UGG/MXLT/BV-298-C [UGG Combined Latencies - AC11ii: 32_1_gr, 32_1_gs]	AC 11(ii)	<-----> <----->	32_1_gr	32_1_gs	2
GMAP/UGG/MXLT/BV-299-C [UGG Combined Latencies - AC11ii: 32_2_gr, 32_2_gs]	AC 11(ii)	<-----> <----->	32_2_gr	32_2_gs	2
GMAP/UGG/MXLT/BV-300-C [UGG Combined Latencies - AC11ii: 48_1_gr, 32_1_gs]	AC 11(ii)	<-----> <----->	48_1_gr	32_1_gs	2
GMAP/UGG/MXLT/BV-301-C [UGG Combined Latencies - AC11ii: 48_2_gr, 32_2_gs]	AC 11(ii)	<-----> <----->	48_2_gr	32_2_gs	2
GMAP/UGG/MXLT/BV-302-C [UGG Combined Latencies - AC11ii: 48_3_gr, 32_1_gs]	AC 11(ii)	<-----> <----->	48_3_gr	32_1_gs	2
GMAP/UGG/MXLT/BV-303-C [UGG Combined Latencies - AC11ii: 48_4_gr, 32_2_gs]	AC 11(ii)	<-----> <----->	48_4_gr	32_2_gs	2

Table 4.14: UGG Max Total Latency in both directions test cases



- Test Procedure
 1. The Upper Tester commands the IUT to establish sink and source audio streams with the Lower Tester(s) in the Audio Configuration and QoS settings described in [Table 4.14](#). The IUT uses Level A parameters specified in [\[5\] Table 3.16: Recommended LL parameters for Unicast QoS configurations 8\(i\) and 8\(ii\)](#) and [\[5\] Table 3.17: Recommended LL parameters for Unicast QoS configurations 11\(i\) and 11\(ii\)](#).
 2. The Audio Signal Generator produces one or more audio bursts to the appropriate Lower Tester's Audio In.
 3. The Latency Timer detects the start of the audio sent to the IUT.
 4. When audio is received at the IUT, it feeds the audio from its internal Audio Out to its internal Audio In, echoing back the audio received from the Lower Tester.
 5. The IUT sends the audio in the established audio stream(s) to the Lower Tester(s).
 6. The Latency Timer detects the audio sent back to the appropriate Lower Tester and determines the total UGG latency, which combines the SDU Sync Ref to Audio Out in the UGT to UGG direction latency, and the Audio In to SDU Sync Ref in the UGG to UGT direction latency.

- Expected Outcome

Pass verdict

The total UGG Latency is no greater than 70 ms. Measured latency up to 70.150 ms is acceptable.

4.5 Audio output synchronization

Verify that one or two UGT or BGR IUTs renders audio outputs to within +/- 100 μ s static and +/- 25 μ s of jitter of each other. These tests employ the test strategies described in [Section 3.2.1.8, Examples of additional latency test approaches](#)

[One](#) or more examples of additional techniques that can be employed to measure audio latency are described in [Appendix A](#).

Audio output synchronization overview and test configurations.

4.5.1 Audio output synchronization between two UGT devices

- Test Purpose

Verify that two UGT IUTs render their audio outputs to within +/- 100 μ s static and +/- 25 μ s of jitter of each other.
- Reference

[\[5\] 3.7](#)
- Initial Condition
 - The Lower Tester is a UGG.
 - The test system is configured as described in [Section 3.2.2.2, Multi-stream synchronization for two Acceptors](#), with IUT 1, IUT 2, Lower Tester, and Upper Tester.
 - The IUTs and the Lower Tester are bonded and connected with ACL connections.
 - The Lower Tester has discovered all relevant services and characteristics of the IUTs.

- Test Case Configuration

Test Case	Audio Configuration	Legend	UGG to UGT QoS Setting	UGT to UGG QoS Setting
GMAP/UGT/SYNC/BV-16-C [Two UGTs Sync - AC6ii: 48_1_gr]	AC 6(ii)	-----> ----->	48_1_gr	N/A
GMAP/UGT/SYNC/BV-17-C [Two UGTs Sync - AC6ii: 48_2_gr]	AC 6(ii)	-----> ----->	48_2_gr	N/A
GMAP/UGT/SYNC/BV-07-C [Two UGTs Sync - AC6ii: 48_3_gr]	AC 6(ii)	-----> ----->	48_3_gr	N/A
GMAP/UGT/SYNC/BV-08-C [Two UGTs Sync - AC6ii: 48_4_gr]	AC 6(ii)	-----> ----->	48_4_gr	N/A
GMAP/UGT/SYNC/BV-01-C [Two UGTs Sync - AC8ii: 48_1_gr, 32_1_gs]	AC 8(ii)	-----> <----->	48_1_gr	32_1_gs
GMAP/UGT/SYNC/BV-02-C [Two UGTs Sync - AC8ii: 48_2_gr, 32_2_gs]	AC 8(ii)	-----> <----->	48_2_gr	32_2_gs
GMAP/UGT/SYNC/BV-20-C [Two UGTs Sync - AC8ii: 48_1_gr, 48_1_gs]	AC 8(ii)	-----> <----->	48_1_gr	48_1_gs
GMAP/UGT/SYNC/BV-21-C [Two UGTs Sync - AC8ii: 48_2_gr, 48_2_gs]	AC 8(ii)	-----> <----->	48_2_gr	48_2_gs
GMAP/UGT/SYNC/BV-22-C [Two UGTs Sync - AC8ii: 48_3_gr, 32_1_gs]	AC 8(ii)	-----> <----->	48_3_gr	32_1_gs
GMAP/UGT/SYNC/BV-23-C [Two UGTs Sync - AC8ii: 48_4_gr, 32_2_gs]	AC 8(ii)	-----> <----->	48_4_gr	32_2_gs
GMAP/UGT/SYNC/BV-03-C [Two UGTs Sync - AC11ii: 48_1_gr, 32_1_gs]	AC 11(ii)	<-----> <----->	48_1_gr	32_1_gs
GMAP/UGT/SYNC/BV-04-C [Two UGTs Sync - AC11ii: 48_2_gr, 32_2_gs]	AC 11(ii)	<-----> <----->	48_2_gr	32_2_gs
GMAP/UGT/SYNC/BV-24-C [Two UGTs Sync - AC11ii: 48_3_gr, 32_1_gs]	AC 11(ii)	<-----> <----->	48_3_gr	32_1_gs
GMAP/UGT/SYNC/BV-25-C [Two UGTs Sync - AC11ii: 48_4_gr, 32_2_gs]	AC 11(ii)	<-----> <----->	48_4_gr	32_2_gs

Table 4.15: Audio output synchronization between two UGT devices test cases



- Test Procedure
 1. The Lower Tester establishes audio streams with IUT 1 and IUT 2 in the Audio Configuration and QoS settings described in [Table 4.15](#). The Lower Tester sends audio defined by Section [3.2.3.1](#), [Audio reference signal](#).
 2. The IUTs output their received audio to the Upper Tester.
 3. The IUT receives audio from the Lower Tester(s).
 4. The Upper Tester measures the audio synchronization using the chosen technique specified in Section [3.2.3](#), [Synchronization test methodologies](#).

- Expected Outcome

Pass verdict

The Audio Outs render audio to within +/- 100 μ s static and +/- 25 μ s of jitter of each other.

4.5.2 Audio output synchronization between two BGR devices

- Test Purpose

Verify that two BGR IUTs render their audio outputs to within +/- 100 μ s static and +/- 25 μ s of jitter of each other.

- Reference

[\[5\]](#) 3.7

- Initial Condition

- The Lower Tester is a BGS.
- The test system is configured as described in Section [3.2.2.2](#), [Multi-stream synchronization for two Acceptors](#), with IUT 1, IUT 2, Lower Tester, and Upper Tester.

- Test Case Configuration





Test Case	Audio Configuration	Legend	QoS Setting
GMAP/BGR/SYNC/BV-03-C [Two BGRs Sync - AC13: 48_1_g]	AC 13		48_1_g
GMAP/BGR/SYNC/BV-04-C [Two BGRs Sync - AC13: 48_2_g]	AC 13		48_2_g
GMAP/BGR/SYNC/BV-01-C [Two BGRs Sync - AC13: 48_3_g]	AC 13		48_3_g
GMAP/BGR/SYNC/BV-02-C [Two BGRs Sync - AC13: 48_4_g]	AC 13		48_4_g

Table 4.16: Audio output synchronization between two BGR devices test cases

- Test Procedure
 1. The Lower Tester broadcasts audio streams in the Audio Configuration and QoS settings described in [Table 4.16](#). The Lower Tester broadcasts audio defined by Section [3.2.3.1](#), [Audio reference signal](#).
 2. The IUTs output their received audio to the Upper Tester.
 3. The Upper Tester measures the audio synchronization using the chosen technique specified in Section [3.2.3](#), [Synchronization test methodologies](#).

- Expected Outcome

Pass verdict

The Audio Outs render audio to within +/- 100 μ s static and +/- 25 μ s of jitter of each other.

4.5.3 Audio output synchronization between two Audio Outs from a single UGT

- Test Purpose

Verify that a UGT IUT renders its two audio outputs to within +/- 100 μ s static and +/- 25 μ s of jitter of each other.
- Reference

[\[5\]](#) 3.7
- Initial Condition
 - The Lower Tester is a UGG.
 - The test system is configured as described in Section [3.2.2.1](#), [Synchronization for devices with two Audio Outs](#).
 - The IUT and the Lower Tester are bonded and connected with ACL connections.
 - The Lower Tester has discovered all relevant services and characteristics of the IUT.

- Test Case Configuration

Test Case	Audio Configuration	Legend	UGG to UGT QoS Setting	UGT to UGG QoS Setting
GMAP/UGT/SYNC/BV-10-C [UGT Audio Outs Sync - AC5: 48_1_gr, 32_1_gs]	AC 5	<----->	48_1_gr	32_1_gs
GMAP/UGT/SYNC/BV-11-C [UGT Audio Outs Sync - AC5: 48_2_gr, 32_2_gs]	AC 5	<----->	48_2_gr	32_2_gs
GMAP/UGT/SYNC/BV-05-C [UGT Audio Outs Sync - AC5: 48_1_gr, 48_1_gs]	AC 5	<----->	48_1_gr	48_1_gs
GMAP/UGT/SYNC/BV-06-C [UGT Audio Outs Sync - AC5: 48_2_gr, 48_2_gs]	AC 5	<----->	48_2_gr	48_2_gs
GMAP/UGT/SYNC/BV-26-C [UGT Audio Outs Sync - AC5: 48_3_gr, 32_1_gs]	AC 5	<----->	48_3_gr	32_1_gs
GMAP/UGT/SYNC/BV-27-C [UGT Audio Outs Sync - AC5: 48_4_gr, 32_2_gs]	AC 5	<----->	48_4_gr	32_2_gs
GMAP/UGT/SYNC/BV-18-C [UGT Audio Outs Sync - AC6i: 48_1_gr]	AC 6(i)	-----> ----->	48_1_gr	N/A
GMAP/UGT/SYNC/BV-19-C [UGT Audio Outs Sync - AC6i: 48_2_gr]	AC 6(i)	-----> ----->	48_2_gr	N/A
GMAP/UGT/SYNC/BV-28-C [UGT Audio Outs Sync - AC6i: 48_3_gr]	AC 6(i)	-----> ----->	48_3_gr	N/A
GMAP/UGT/SYNC/BV-29-C [UGT Audio Outs Sync - AC6i: 48_4_gr]	AC 6(i)	-----> ----->	48_4_gr	N/A
GMAP/UGT/SYNC/BV-12-C [UGT Audio Outs Sync - AC8i: 48_1_gr, 32_1_gs]	AC 8(i)	-----> <----->	48_1_gr	32_1_gs
GMAP/UGT/SYNC/BV-13-C [UGT Audio Outs Sync - AC8i: 48_2_gr, 32_2_gs]	AC 8(i)	-----> <----->	48_2_gr	32_2_gs
GMAP/UGT/SYNC/BV-30-C [UGT Audio Outs Sync - AC8i: 48_1_gr, 48_1_gs]	AC 8(i)	-----> <----->	48_1_gr	48_1_gs
GMAP/UGT/SYNC/BV-31-C [UGT Audio Outs Sync - AC8i: 48_2_gr, 48_2_gs]	AC 8(i)	-----> <----->	48_2_gr	48_2_gs
GMAP/UGT/SYNC/BV-32-C [UGT Audio Outs Sync - AC8i: 48_3_gr, 32_1_gs]	AC 8(i)	-----> <----->	48_3_gr	32_1_gs
GMAP/UGT/SYNC/BV-33-C [UGT Audio Outs Sync - AC8i: 48_4_gr, 32_2_gs]	AC 8(i)	-----> <----->	48_4_gr	32_2_gs
GMAP/UGT/SYNC/BV-14-C [UGT Audio Outs Sync - AC11i: 48_1_gr, 32_1_gs]	AC 11(i)	<-----> <----->	48_1_gr	32_1_gs



Test Case	Audio Configuration	Legend	UGG to UGT QoS Setting	UGT to UGG QoS Setting
GMAP/UGT/SYNC/BV-15-C [UGT Audio Outs Sync - AC11i: 48_2_gr, 32_2_gs]	AC 11(i)	<-----> <----->	48_2_gr	32_2_gs
GMAP/UGT/SYNC/BV-34-C [UGT Audio Outs Sync - AC11i: 48_3_gr, 32_1_gs]	AC 11(i)	<-----> <----->	48_3_gr	32_1_gs
GMAP/UGT/SYNC/BV-35-C [UGT Audio Outs Sync - AC11i: 48_4_gr, 32_2_gs]	AC 11(i)	<-----> <----->	48_4_gr	32_2_gs

Table 4.17: Audio output synchronization between two Audio Outs from a single UGT test cases

- Test Procedure
 1. The Lower Tester establishes audio streams with the IUT in the Audio Configuration and QoS settings described in [Table 4.17](#). The Lower Tester sends audio defined by Section [3.2.3.1](#), [Audio reference signal](#).
 2. The IUT outputs the audio to the Upper Tester.
 3. The Upper Tester measures the audio synchronization using the chosen technique specified in Section [3.2.3](#), [Synchronization test methodologies](#).

- Expected Outcome

Pass verdict

The Audio Outs render audio to within +/- 100 μ s static and +/- 25 μ s of jitter of each other.

4.5.4 Audio output synchronization between two Audio Outs from a single BGR

- Test Purpose

Verify that a BGR IUT renders its two audio outputs to within +/- 100 μ s static and +/- 25 μ s of jitter of each other.
- Reference

[\[5\]](#) 3.7
- Initial Condition
 - The Lower Tester is a BGS.
 - The test system is configured as described in Section [3.2.2.1](#), [Synchronization for devices with two Audio Outs](#).

- Test Case Configuration









Test Case	Audio Configuration	Legend	QoS Setting
GMAP/BGR/SYNC/BV-07-C [BGR Audio Outs Sync - AC13: 48_1_g]	AC 13		48_1_g
GMAP/BGR/SYNC/BV-08-C [BGR Audio Outs Sync - AC13: 48_2_g]	AC 13		48_2_g
GMAP/BGR/SYNC/BV-05-C [BGR Audio Outs Sync - AC13: 48_3_g]	AC 13		48_3_g
GMAP/BGR/SYNC/BV-06-C [BGR Audio Outs Sync - AC13: 48_4_g]	AC 13		48_4_g
GMAP/BGR/SYNC/BV-09-C [BGR Audio Outs Sync - AC14: 48_1_g]	AC 14		48_1_g
GMAP/BGR/SYNC/BV-10-C [BGR Audio Outs Sync - AC14: 48_2_g]	AC 14		48_2_g
GMAP/BGR/SYNC/BV-11-C [BGR Audio Outs Sync - AC14: 48_3_g]	AC 14		48_3_g
GMAP/BGR/SYNC/BV-12-C [BGR Audio Outs Sync - AC14: 48_4_g]	AC 14		48_4_g

Table 4.18: Audio output synchronization between two Audio Outs from a single BGR test cases

- Test Procedure
 1. The Lower Tester broadcasts audio streams in the Audio Configuration and QoS settings described in [Table 4.18](#). The Lower Tester broadcasts audio defined by Section [3.2.3.1](#), [Audio reference signal](#).
 2. The IUT outputs the audio to the Upper Tester.
 3. The Upper Tester measures the audio synchronization using the chosen technique specified in Section [3.2.3](#), [Synchronization test methodologies](#).

- Expected Outcome

Pass verdict

The Audio Outs render audio to within +/- 100 μ s static and +/- 25 μ s of jitter of each other.

4.6 GMA Client and Server

Verify the requirements of the GMA Client and Server.

4.6.1 GMA Client

4.6.1.1 Generic GATT Integrated Tests

Execute the Generic GATT Integrated Tests defined in Section 6.4, Client test procedures (CGGIT), in [8] using [Table 4.19](#) below for input:

TCID	Service / Characteristic	Reference	Properties	Value Length (Octets)	Type
GMAP/CL/CGGIT/SER/BV-01-C [GMAS Service Discovery]	Gaming Audio Service	[5] 4	-	-	Primary Service, Unique
GMAP/CL/CGGIT/CHA/BV-01-C [GMAP Role Read Characteristic, Client]	GMAP Role	[5] 4.7	Read	1	Unique
GMAP/CL/CGGIT/CHA/BV-03-C [UGG Features Read Characteristic, Client]	UGG Features	[5] 4.7	Read	1	Unique
GMAP/CL/CGGIT/CHA/BV-02-C [UGT Features Read Characteristic, Client]	UGT Features	[5] 4.7	Read	1	Unique
GMAP/CL/CGGIT/CHA/BV-04-C [BGS Features Read Characteristic, Client]	BGS Features	[5] 4.7	Read	1	Unique
GMAP/CL/CGGIT/CHA/BV-05-C [BGR Features Read Characteristic, Client]	BGR Features	[5] 4.7	Read	1	Unique

Table 4.19: Input for the GGIT Client test procedure



4.6.1.2 Invalid Behavior

Verify the requirements of the GMA Client when subjected to invalid behavior.

GMAP/CL/GMAS/BI-01-C [Client Ignores RFU Bits in GMAP Role Characteristic]

- Test Purpose

Verify that a GMA Client IUT ignores RFU bits when reading the GMAP Role characteristic from a GMA Server.
- Reference

[5] 4.7.1.2
- Initial Condition
 - The Lower Tester is a GMA Server.
 - The Role characteristic in the Lower Tester includes all the defined role bits, and the RFU bits are set.
 - The IUT has discovered the Lower Tester's GMAS service.
- Test Procedure
 1. The Upper Tester sends a request to the IUT to read the GMAP Role characteristic value from the Lower Tester, specifying the characteristic handle.
 2. The Lower Tester provides the value of the GMAP Role characteristic.
- Expected Outcome

Pass verdict

The IUT indicates to the Upper Tester that all defined roles in the GMAP Role characteristic are supported.

GMAP/CL/GMAS/BI-03-C [Client Ignores RFU Bits in UGG Features Characteristic]

- Test Purpose

Verify that a GMA Client IUT ignores RFU bits when reading the UGG Features characteristic from a GMA Server.
- Reference

[5] 4.7.2.2
- Initial Condition
 - The Lower Tester is a GMA Server.
 - The UGT Features characteristic in the Lower Tester includes all the defined feature bits, and the RFU bits are set.
 - The IUT has discovered the Lower Tester's GMAS service.
- Test Procedure
 1. The Upper Tester sends a request to the IUT to read the UGT Features characteristic value from the Lower Tester, specifying the characteristic handle.
 2. The Lower Tester provides the value of the UGT Features characteristic.

- Expected Outcome

Pass verdict

The IUT indicates to the Upper Tester that all defined features in the UGT Features characteristic are supported.

GMAP/CL/GMAS/BI-02-C [Client Ignores RFU Bit in UGT Features Characteristic]

- Test Purpose

Verify that a GMA Client IUT ignores the RFU bit when reading the UGT Features characteristic from a GMA Server.

- Reference

[5] 4.7.3.2

- Initial Condition

- The Lower Tester is a GMA Server.
- The UGT Features characteristic in the Lower Tester includes all the defined feature bits, and the RFU bit is set.
- The IUT has discovered the Lower Tester's GMAS service.

- Test Procedure

1. The Upper Tester sends a request to the IUT to read the UGT Features characteristic value from the Lower Tester, specifying the characteristic handle.
2. The Lower Tester provides the value of the UGT Features characteristic.

- Expected Outcome

Pass verdict

The IUT indicates to the Upper Tester that all defined features in the UGT Features characteristic are supported.

GMAP/CL/GMAS/BI-04-C [Client Ignores RFU Bits in BGS Features Characteristic]

- Test Purpose

Verify that a GMA Client IUT ignores RFU bits when reading the BGS Features characteristic from a GMA Server.

- Reference

[5] 4.7.4.2

- Initial Condition

- The Lower Tester is a GMA Server.
- The BGS Features characteristic in the Lower Tester includes all the defined feature bits, and the RFU bits are set.
- The IUT has discovered the Lower Tester's GMAS service.

- Test Procedure
 1. The Upper Tester sends a request to the IUT to read the BGS Features characteristic value from the Lower Tester, specifying the characteristic handle.
 2. The Lower Tester provides the value of the BGS Features characteristic.

- Expected Outcome

Pass verdict

The IUT indicates to the Upper Tester that all defined features in the BGS Features characteristic are supported.

GMAP/CL/GMAS/BI-05-C [Client Ignores RFU Bits in BGR Features Characteristic]

- Test Purpose

Verify that a GMA Client IUT ignores RFU bits when reading the BGR Features characteristic from a GMA Server.

- Reference

[5] 4.7.5.2

- Initial Condition

- The Lower Tester is a GMA Server.
- The BGR Features characteristic in the Lower Tester includes all the defined feature bits, and the RFU bits are set.
- The IUT has discovered the Lower Tester's GMAS service.

- Test Procedure

1. The Upper Tester sends a request to the IUT to read the BGR Features characteristic value from the Lower Tester, specifying the characteristic handle.
2. The Lower Tester provides the value of the BGR Features characteristic.

- Expected Outcome

Pass verdict

The IUT indicates to the Upper Tester that all defined features in the BGR Features characteristic are supported.

4.6.2 GMA Server

4.6.2.1 Generic GATT Integrated Tests

Execute the Generic GATT Integrated Tests defined in Section 6.3, Server test procedures (SGGIT), in [8] using Table 4.20 below as input:

TCID	Service / Characteristic	Reference	Properties	Value Length (Octets)	Type
GMAP/SR/SGGIT/SER/BV-01-C [Service GGIT - GMAP]	Gaming Audio Service	[5] 4	-	-	Primary Service, Unique
GMAP/SR/SGGIT/CHA/BV-01-C [Characteristic GGIT - GMAP Role]	GMAP Role	[5] 4.7	0x02 (Read)	1	
GMAP/SR/SGGIT/CHA/BV-03-C [Characteristic GGIT - UGG Features]	UGG Features	[5] 4.7	0x02 (Read)	1	
GMAP/SR/SGGIT/CHA/BV-02-C [Characteristic GGIT - UGT Features]	UGT Features	[5] 4.7	0x02 (Read)	1	
GMAP/SR/SGGIT/CHA/BV-04-C [Characteristic GGIT - BGS Features]	BGS Features	[5] 4.7	0x02 (Read)	1	
GMAP/SR/SGGIT/CHA/BV-05-C [Characteristic GGIT - BGR Features]	BGR Features	[5] 4.7	0x02 (Read)	1	
GMAP/SR/SGGIT/SDP/BV-01-C [SDP Record]	Gaming Audio Service	[5] 4.9	-	-	Unique

Table 4.20: Input for the GGIT Server test procedure



4.6.2.2 GMAP Role characteristic

- Test Purpose

Verify that the GMA Server returns the GMAP Role characteristic with the correct bit set for its GMAP role.

- Reference

[5] 4.7.1

- Initial Condition

- If LE transport is specified in [Table 4.21](#), then the IUT and the Lower Tester have not bonded.
- The Lower Tester is a GMA Client and has established a GATT Connection with the IUT as a GMA Server using security mode 1 level 1 over LE transport if LE transport is specified in [Table 4.21](#), or security mode 4 level 0 or higher over BR/EDR transport if BR/EDR transport is specified in [Table 4.21](#).

- Test Case Configuration

Test Case	Role Characteristic	Value	Transport
GMAP/UGG/GRC/BV-01-C [UGG Characteristic over LE]	Unicast Game Gateway (UGG)	0x01	LE
GMAP/UGT/GRC/BV-01-C [UGT Characteristic over LE]	Unicast Game Terminal (UGT)	0x02	LE
GMAP/BGS/GRC/BV-01-C [BGS Characteristic over LE]	Broadcast Game Sender (BGS)	0x04	LE
GMAP/BGR/GRC/BV-01-C [BGR Characteristic over LE]	Broadcast Game Receiver (BGR)	0x08	LE
GMAP/UGG/GRC/BV-02-C [UGG Characteristic over BR/EDR]	Unicast Game Gateway (UGG)	0x01	BR/EDR
GMAP/UGT/GRC/BV-02-C [UGT Characteristic over BR/EDR]	Unicast Game Terminal (UGT)	0x02	BR/EDR
GMAP/BGS/GRC/BV-02-C [BGS Characteristic over BR/EDR]	Broadcast Game Sender (BGS)	0x04	BR/EDR
GMAP/BGR/GRC/BV-02-C [BGR Characteristic over BR/EDR]	Broadcast Game Receiver (BGR)	0x08	BR/EDR

Table 4.21: GMAP Role characteristic test cases

- Test Procedure

1. The Lower Tester executes the GATT Read Characteristic Value sub-procedure and the GATT Read Using Characteristic UUID sub-procedure to read the GMAP Role characteristic using the appropriate security mode.

- Expected Outcome

Pass verdict

The IUT sets the appropriate bit for its supported GMAP Role specified in the Value column in [Table 4.21](#).

RFU bits 4–7 = 0b0000.

If LE transport is specified in [Table 4.21](#), then the IUT does not bond with the Lower Tester.



4.6.2.3 UGG Features characteristic

- Test Purpose

Verify that the GMA Server returns the UGG Features characteristic with the correct bits set for its supported UGG features.

- Reference

[5] 4.7.2

- Initial Condition

- If LE transport is specified in [Table 4.22](#), then the IUT and the Lower Tester have not bonded.
- The Lower Tester is a GMA Client and has established a GATT Connection with the IUT as a GMA Server using security mode 1 level 1 over LE transport if LE transport is specified in [Table 4.22](#), or security mode 4 level 0 or higher over BR/EDR transport if BR/EDR transport is specified in [Table 4.22](#).

- Test Case Configuration

Test Case	UGG Feature Description	Value	Transport
GMAP/UGG/GRC/BV-03-C [UGG Multiplex feature support, over LE]	UGG Multiplex feature support	0x01	LE
GMAP/UGG/GRC/BV-04-C [UGG 96 kbps Source feature support, over LE]	UGG 96 kbps Source feature support	0x02	LE
GMAP/UGG/GRC/BV-05-C [UGG Multisink feature support, over LE]	UGG Multisink feature support	0x04	LE
GMAP/UGG/GRC/BV-06-C [UGG Multiplex feature support, over BR/EDR]	UGG Multiplex feature support	0x01	BR/EDR
GMAP/UGG/GRC/BV-07-C [UGG 96 kbps Source feature support, over BR/EDR]	UGG 96 kbps Source feature support	0x02	BR/EDR
GMAP/UGG/GRC/BV-08-C [UGG Multisink feature support, over BR/EDR]	UGG Multisink feature support	0x04	BR/EDR

Table 4.22: UGG Features characteristic test cases

- Test Procedure

1. The Lower Tester executes the GATT Read Characteristic Value sub-procedure and the GATT Read Using Characteristic UUID sub-procedure to read the UGG Features characteristic using the appropriate security mode.

- Expected Outcome

Pass verdict

The IUT sets the appropriate bit for its supported UGG Features specified in the Value column in [Table 4.22](#).

RFU bits 3–7 = 0b0000.

If LE transport is specified in [Table 4.22](#), then the IUT does not bond with the Lower Tester.

4.6.2.4 UGT Features characteristic

- Test Purpose

Verify that the GMA Server returns the UGT Features characteristic with the correct bits set for its supported UGT features.

- Reference

[5] 4.7.3

- Initial Condition

- If LE transport is specified in [Table 4.23](#), then the IUT and the Lower Tester have not bonded.
- The Lower Tester is a GMA Client and has established a GATT Connection with the IUT as a GMA Server using security mode 1 level 1 over LE transport if LE transport is specified in [Table 4.23](#), or security mode 4 level 0 or higher over BR/EDR transport if BR/EDR transport is specified in [Table 4.23](#).

- Test Case Configuration

Test Case	UGT Feature Description	Value	Transport
GMAP/UGT/GRC/BV-03-C [UGT Source feature support, over LE]	UGT Source feature support	0x01	LE
GMAP/UGT/GRC/BV-04-C [UGT 80 kbps Source feature support, over LE]	UGT 80 kbps Source feature support	0x02	LE
GMAP/UGT/GRC/BV-05-C [UGT Sink feature support, over LE]	UGT Sink feature support	0x04	LE
GMAP/UGT/GRC/BV-09-C [UGT 64 kbps Sink feature support, over LE]	UGT 64 kbps Sink feature support	0x08	LE
GMAP/UGT/GRC/BV-10-C [UGT Multiplex feature support, over LE]	UGT Multiplex feature support	0x10	LE
GMAP/UGT/GRC/BV-11-C [UGT Multisink feature support, over LE]	UGT Multisink feature support	0x20	LE
GMAP/UGT/GRC/BV-12-C [UGT Multisource feature support, over LE]	UGT Multisource feature support	0x40	LE
GMAP/UGT/GRC/BV-06-C [UGT Source feature support, over BR/EDR]	UGT Source feature support	0x01	BR/EDR
GMAP/UGT/GRC/BV-07-C [UGT 80 kbps Source feature support, over BR/EDR]	UGT 80 kbps Source feature support	0x02	BR/EDR
GMAP/UGT/GRC/BV-08-C [UGT Sink feature support, over BR/EDR]	UGT Sink feature support	0x04	BR/EDR
GMAP/UGT/GRC/BV-13-C [UGT 64 kbps Sink feature support, over BR/EDR]	UGT 64 kbps Sink feature support	0x08	BR/EDR
GMAP/UGT/GRC/BV-14-C [UGT Multiplex feature support, over BR/EDR]	UGT Multiplex feature support	0x10	BR/EDR
GMAP/UGT/GRC/BV-15-C [UGT Multisink feature support, over BR/EDR]	UGT Multisink feature support	0x20	BR/EDR
GMAP/UGT/GRC/BV-16-C [UGT Multisource feature support, over BR/EDR]	UGT Multisource feature support	0x40	BR/EDR

Table 4.23: UGT Features characteristic test cases



- Test Procedure
 1. The Lower Tester executes the GATT Read Characteristic Value sub-procedure and the GATT Read Using Characteristic UUID sub-procedure to read the UGT Features characteristic using the appropriate security mode.

- Expected Outcome

Pass verdict

The IUT sets the appropriate bit for its supported UGT Features specified in the Value column in [Table 4.23](#).

RFU bit 7 = 0b0.

If LE transport is specified in [Table 4.23](#), then the IUT does not bond with the Lower Tester.

4.6.2.5 BGS Features characteristic

- Test Purpose

Verify that the GMA Server returns the BGS Features characteristic with the correct bits set for its supported BGS features.

- Reference

[5] 4.7.4

- Initial Condition

- If LE transport is specified in [Table 4.24](#), then the IUT and the Lower Tester have not bonded.
- The Lower Tester is a GMA Client and has established a GATT Connection with the IUT as a GMA Server using security mode 1 level 1 over LE transport if LE transport is specified in [Table 4.24](#), or security mode 4 level 0 or higher over BR/EDR transport if BR/EDR transport is specified in [Table 4.24](#).

- Test Case Configuration

Test Case	BGS Feature Description	Value	Transport
GMAP/BGS/GRC/BV-03-C [BGS 96 kbps Source feature support, over LE]	BGS 96 kbps Source feature support	0x01	LE
GMAP/BGS/GRC/BV-04-C [BGS 96 kbps Source feature support, over BR/EDR]	BGS 96 kbps Source feature support	0x01	BR/EDR

Table 4.24: BGS Features characteristic test cases

- Test Procedure

1. The Lower Tester executes the GATT Read Characteristic Value sub-procedure and the GATT Read Using Characteristic UUID sub-procedure to read the BGS Features characteristic using the appropriate security mode.

- Expected Outcome

Pass verdict

The IUT sets the appropriate bit for its supported BGS Features specified in the Value column in [Table 4.24](#).



RFU bits 1–7 = 0b0000000.

If LE transport is specified in [Table 4.24](#), then the IUT does not bond with the Lower Tester.

4.6.2.6 BGR Features characteristic

- Test Purpose

Verify that the GMA Server returns the BGR Features characteristic with the correct bits set for its supported BGR features.

- Reference

[5] 4.7.5

- Initial Condition

- If LE transport is specified in [Table 4.25](#), then the IUT and the Lower Tester have not bonded.
- The Lower Tester is a GMA Client and has established a GATT Connection with the IUT as a GMA Server using security mode 1 level 1 over LE transport if LE transport is specified in [Table 4.25](#), or security mode 4 level 0 or higher over BR/EDR transport if BR/EDR transport is specified in [Table 4.25](#).

- Test Case Configuration

Test Case	BGR Feature Description	Value	Transport
GMAP/BGR/GRC/BV-03-C [BGR Multisink feature support, over LE]	BGR Multisink feature support	0x01	LE
GMAP/BGR/GRC/BV-04-C [BGR Multiplex feature support, over LE]	BGR Multiplex feature support	0x02	LE
GMAP/BGR/GRC/BV-05-C [BGR Multisink feature support, over BR/EDR]	BGR Multisink feature support	0x01	BR/EDR
GMAP/BGR/GRC/BV-06-C [BGR Multiplex feature support, over BR/EDR]	BGR Multiplex feature support	0x02	BR/EDR

Table 4.25: BGR Features characteristic test cases

- Test Procedure

1. The Lower Tester executes the GATT Read Characteristic Value sub-procedure and the GATT Read Using Characteristic UUID sub-procedure to read the BGR Features characteristic using the appropriate security mode.

- Expected Outcome

Pass verdict

The IUT sets the appropriate bit for its supported BGR Features specified in the Value column in [Table 4.25](#).

RFU bits 2–7 = 0b0000000.

If LE transport is specified in [Table 4.25](#), then the IUT does not bond with the Lower Tester.

4.7 Device discovery and connection establishment

Verify that a GMAP device that supports advertising its GMAP role to support device discovery and connection establishment while in bondable mode does so correctly.

4.7.1 Device discovery – Role characteristic

- Test Purpose

Verify that the IUT advertises its GMAP role in extended advertisements in the correct format and reports the correct GMAP role characteristic.

- Reference

[5] 3.4

- Initial Condition

- The IUT is in bondable mode.

- Test Case Configuration

Test Case	GMAP Role Characteristic
GMAP/UGG/DDI/BV-01-C [Discovery of UGG]	Unicast Game Gateway (UGG)
GMAP/UGT/DDI/BV-01-C [Discovery of UGT]	Unicast Game Terminal (UGT)
GMAP/BGS/DDI/BV-01-C [Discovery of BGS]	Broadcast Game Sender (BGS)
GMAP/BGR/DDI/BV-01-C [Discovery of BGR]	Broadcast Game Receiver (BGR)

Table 4.26: Device discovery – Role characteristic test cases

- Test Procedure

1. The Upper Tester orders the IUT to advertise its GMAP Role characteristic in extended advertising as specified in [Table 4.26](#).

- Expected Outcome

Pass verdict

The IUT advertises its GMAP Role characteristic in the correct LTV format, which includes the GMAS UUID.

- Notes

Because an IUT may support more than one GMAP role, it may report more roles than the role specified in [Table 4.26](#).

4.8 Audio Locations and Supported Audio Contexts

Verify that the Acceptor IUT supports the correct Audio Location or Context Type.

4.8.1 BGR Audio Location

- Test Purpose

Verify that the BGR IUT supports the required Audio Location value in the Sink_Audio_Locations characteristic.

- Reference

[5] 3.5.2.2



- Initial Condition
 - The Lower Tester is a BGS.
 - The Lower Tester has discovered the Published Audio Capabilities Service [14] and characteristics.
- Test Case Configuration

Test Case	Audio Location Value
GMAP/BGR/AL/BV-01-C [BGR Audio Location Front Left]	0b01
GMAP/BGR/AL/BV-02-C [BGR Audio Location Front Right]	0b10
GMAP/BGR/AL/BV-03-C [BGR Audio Location Front Right and Front Left]	0b11

Table 4.27: BGR Audio Location test cases

- Test Procedure
 1. The Lower Tester executes the GATT Read Characteristic Value sub-procedure with the Sink Audio Locations characteristic.
- Expected Outcome

Pass verdict

The characteristic is successfully read and the IUT's Audio Location Value in the Sink Audio Locations characteristic matches the value specified in [Table 4.27](#).

[GMAP/BGR/SAC/BV-01-C \[BGR Includes Game Context Type\]](#)

- Test Purpose

Verify that the BGR IUT includes the "Game" Context Type value in the Supported_Sink_Contexts field of the Supported Audio Contexts characteristic.
- Reference

[\[15\] 3.5.2.1](#)
- Initial Condition
 - The Lower Tester is a BGS.
 - The Lower Tester has discovered the Published Audio Capabilities Service [14] and characteristics.
- Test Procedure
 1. The Lower Tester executes the GATT Read Characteristic Value sub-procedure with the Supported Audio Contexts characteristic.
- Expected Outcome

Pass verdict

The IUT's Supported_Sink_Contexts field in the Supported Audio Contexts characteristic includes support for the "Game" Context Type.

4.9 Updating Metadata

Verify that the GMAP Initiator IUT correctly updates metadata.

GMAP/BGS/META/BV-01-C [BGS updates Audio Contexts]

- Test Purpose

Verify that a BGS uses the Streaming_Audio_Contexts LTV structure in the Metadata parameter in the BASE with the value “Game” when updating metadata for a broadcast audio stream.

- Reference

[15] 3.5.2.1

- Initial Condition

- The initial condition is as specified for CAP/INI/BST/BV-11-C in [12]. The TSPX_BASE and TSPX_BASE_UPDATE IXIT entries include the Streaming_Audio_Contexts LTV structure with the value “Game”. In addition to “Game”, TSPX_BASE_UPDATE includes the value “Media”.

- Test Procedure

1. Execute the CAP test procedure in CAP/INI/BST/BV-11-C.

- Expected Outcome

Pass verdict

The Pass verdict for CAP/INI/BST/BV-11-C is met.

GMAP/UGG/META/BV-01-C [UGG updates Source ASE metadata]

- Test Purpose

Verify that a UGG uses the Streaming_Audio_Contexts LTV structure in the Metadata parameter with the value “Game” when updating metadata for a Source ASE.

- Reference

[15] 3.5.1.1

- Initial Condition

- The initial condition is as specified for CAP/INI/UST/BV-32-C in [12].

- Test Procedure

1. Execute the CAP test procedure in CAP/INI/UST/BV-32-C with the IXIT parameter TSPX_Streaming_Audio_Contexts set to “Game”.

- Expected Outcome

Pass verdict

The Pass verdict for CAP/INI/UST/BV-32-C is met.

GMAP/UGG/META/BV-02-C [UGG updates Sink ASE metadata]

- Test Purpose

Verify that a UGG uses the Streaming_Audio_Contexts LTV structure in the Metadata parameter with the value “Game” when updating metadata for a Sink ASE.

- Reference

[15] 3.5.1.1

- Initial Condition

- The initial condition is as specified for CAP/INI/UST/BV-33-C in [12].

- Test Procedure

1. Execute the CAP test procedure in CAP/INI/UST/BV-33-C with the IXIT parameter TSPX_Streaming_Audio_Contexts set to “Game”.

- Expected Outcome

Pass verdict

The Pass verdict for CAP/INI/UST/BV-33-C is met.

5 Test case mapping

The Test Case Mapping Table (TCMT) maps test cases to specific requirements in the ICS. The IUT is tested in all roles for which support is declared in the ICS document.

The columns for the TCMT are defined as follows:

Item: Contains a logical expression based on specific entries from the associated ICS document. Contains a logical expression (using the operators AND, OR, NOT as needed) based on specific entries from the applicable ICS document(s). The entries are in the form of y/x references, where y corresponds to the table number and x corresponds to the feature number as defined in the ICS document for Gaming Audio Profile (GMAP) [6].

If a test case is mandatory within the respective layer, then the y/x reference is omitted.

Feature: A brief, informal description of the feature being tested.

Test Case(s): The applicable test case identifiers are required for Bluetooth Qualification if the corresponding y/x references defined in the Item column are supported. Further details about the function of the TCMT are elaborated in [2].

For the purpose and structure of the ICS/IXIT, refer to [2].

Item	Feature	Test Case(s)
GMAP 21/2	UGG metadata updates	GMAP/UGG/META/BV-01-C GMAP/UGG/META/BV-02-C
GMAP 13/1	Discovery of UGG	GMAP/UGG/DDI/BV-01-C
GMAP 103/1	UGG Characteristic over LE	GMAP/UGG/GRC/BV-01-C
GMAP 103/1 AND GMAP 108/2	UGG Characteristic over BR/EDR	GMAP/UGG/GRC/BV-02-C
GMAP 104/1	UGG Features Characteristic over LE - UGG Multiplex	GMAP/UGG/GRC/BV-03-C
GMAP 104/2	UGG Features Characteristic over LE - UGG 96 kbps Source	GMAP/UGG/GRC/BV-04-C
GMAP 104/3	UGG Features Characteristic over LE - UGG Multisink	GMAP/UGG/GRC/BV-05-C
GMAP 104/1 AND GMAP 108/2	UGG Features Characteristic over BR/EDR - UGG Multiplex	GMAP/UGG/GRC/BV-06-C
GMAP 104/2 AND GMAP 108/2	UGG Features Characteristic over BR/EDR - UGG 96 kbps Source	GMAP/UGG/GRC/BV-07-C
GMAP 104/3 AND GMAP 108/2	UGG Features Characteristic over BR/EDR - UGG Multisink	GMAP/UGG/GRC/BV-08-C
GMAP 20/1	Low Latency Streaming - AC1: 32_1_gr	GMAP/UGG/LLU/BV-63-C
GMAP 20/1 AND GMAP 15/1	Audio In to SDU Sync Latency - AC1: 32_1_gr	GMAP/UGG/MXLT/BV-55-C
GMAP 20/2	Low Latency Streaming - AC1: 32_2_gr	GMAP/UGG/LLU/BV-64-C
GMAP 20/2 AND GMAP 15/1	Audio In to SDU Sync Latency - AC1: 32_2_gr	GMAP/UGG/MXLT/BV-56-C
GMAP 20/3	Low Latency Streaming - AC1: 48_1_gr	GMAP/UGG/LLU/BV-51-C
GMAP 20/3 AND GMAP 15/1	Audio In to SDU Sync Latency - AC1: 48_1_gr	GMAP/UGG/MXLT/BV-37-C

Item	Feature	Test Case(s)
GMAP 20/4	Low Latency Streaming - AC1: 48_2_gr	GMAP/UGG/LLU/BV-52-C
GMAP 20/4 AND GMAP 15/1	Audio In to SDU Sync Latency - AC1: 48_2_gr	GMAP/UGG/MXLT/BV-38-C
GMAP 20/5	Low Latency Streaming - AC1: 48_3_gr	GMAP/UGG/LLU/BV-53-C
GMAP 20/5 AND GMAP 15/1	Audio In to SDU Sync Latency - AC1: 48_3_gr	GMAP/UGG/MXLT/BV-39-C
GMAP 20/6	Low Latency Streaming - AC1: 48_4_gr	GMAP/UGG/LLU/BV-54-C
GMAP 20/6 AND GMAP 15/1	Audio In to SDU Sync Latency - AC1: 48_4_gr	GMAP/UGG/MXLT/BV-40-C
GMAP 20/7	Low Latency Streaming - AC2: 16_1_gs	GMAP/UGG/LLU/BV-87-C
GMAP 20/7 AND GMAP 15/2	SDU Sync to Audio Out Latency - AC2: 16_1_gs	GMAP/UGG/MXLT/BV-148-C
GMAP 20/8	Low Latency Streaming - AC2: 16_2_gs	GMAP/UGG/LLU/BV-88-C
GMAP 20/8 AND GMAP 15/2	SDU Sync to Audio Out Latency - AC2: 16_2_gs	GMAP/UGG/MXLT/BV-149-C
GMAP 20/9	Low Latency Streaming - AC2: 32_1_gs	GMAP/UGG/LLU/BV-55-C
GMAP 20/9 AND GMAP 15/2	SDU Sync to Audio Out Latency - AC2: 32_1_gs	GMAP/UGG/MXLT/BV-80-C
GMAP 20/10	Low Latency Streaming - AC2: 32_2_gs	GMAP/UGG/LLU/BV-56-C
GMAP 20/10 AND GMAP 15/2	SDU Sync to Audio Out Latency - AC2: 32_2_gs	GMAP/UGG/MXLT/BV-81-C
GMAP 20/11	Low Latency Streaming - AC2: 48_1_gs	GMAP/UGG/LLU/BV-57-C
GMAP 20/11 AND GMAP 15/2	SDU Sync to Audio Out Latency - AC2: 48_1_gs	GMAP/UGG/MXLT/BV-82-C
GMAP 20/12	Low Latency Streaming - AC2: 48_2_gs	GMAP/UGG/LLU/BV-58-C
GMAP 20/12 AND GMAP 15/2	SDU Sync to Audio Out Latency - AC2: 48_2_gs	GMAP/UGG/MXLT/BV-83-C
GMAP 20/27	Low Latency Streaming - AC4: 32_1_gr	GMAP/UGG/LLU/BV-69-C
GMAP 20/27 AND GMAP 15/1	Audio In to SDU Sync Latency - AC4: 32_1_gr	GMAP/UGG/MXLT/BV-61-C
GMAP 20/28	Low Latency Streaming - AC4: 32_2_gr	GMAP/UGG/LLU/BV-70-C
GMAP 20/28 AND GMAP 15/1	Audio In to SDU Sync Latency - AC4: 32_2_gr	GMAP/UGG/MXLT/BV-62-C
GMAP 20/29	Low Latency Streaming - AC4: 48_1_gr	GMAP/UGG/LLU/BV-59-C
GMAP 20/29 AND GMAP 15/1	Audio In to SDU Sync Latency - AC4: 48_1_gr	GMAP/UGG/MXLT/BV-41-C
GMAP 20/30	Low Latency Streaming - AC4: 48_2_gr	GMAP/UGG/LLU/BV-60-C
GMAP 20/30 AND GMAP 15/1	Audio In to SDU Sync Latency - AC4: 48_2_gr	GMAP/UGG/MXLT/BV-42-C
GMAP 20/31	Low Latency Streaming - AC4: 48_3_gr	GMAP/UGG/LLU/BV-61-C
GMAP 20/31 AND GMAP 15/1	Audio In to SDU Sync Latency - AC4: 48_3_gr	GMAP/UGG/MXLT/BV-43-C
GMAP 20/32	Low Latency Streaming - AC4: 48_4_gr	GMAP/UGG/LLU/BV-62-C
GMAP 20/32 AND GMAP 15/1	Audio In to SDU Sync Latency - AC4: 48_4_gr	GMAP/UGG/MXLT/BV-44-C

Item	Feature	Test Case(s)
GMAP 20/45	Low Latency Streaming - AC6i: 32_1_gr	GMAP/UGG/LLU/BV-73-C
GMAP 20/45 AND GMAP 15/1	Audio In to SDU Sync Latency - AC6i: 32_1_gr	GMAP/UGG/MXLT/BV-65-C
GMAP 20/46	Low Latency Streaming - AC6i: 32_2_gr	GMAP/UGG/LLU/BV-74-C
GMAP 20/46 AND GMAP 15/1	Audio In to SDU Sync Latency - AC6i: 32_2_gr	GMAP/UGG/MXLT/BV-66-C
GMAP 20/47	Low Latency Streaming - AC6i: 48_1_gr	GMAP/UGG/LLU/BV-01-C
GMAP 20/47 AND GMAP 15/1	Audio In to SDU Sync Latency - AC6i: 48_1_gr	GMAP/UGG/MXLT/BV-29-C
GMAP 20/48	Low Latency Streaming - AC6i: 48_2_gr	GMAP/UGG/LLU/BV-02-C
GMAP 20/48 AND GMAP 15/1	Audio In to SDU Sync Latency - AC6i: 48_2_gr	GMAP/UGG/MXLT/BV-30-C
GMAP 20/49	Low Latency Streaming - AC6i: 48_3_gr	GMAP/UGG/LLU/BV-03-C
GMAP 20/49 AND GMAP 15/1	Audio In to SDU Sync Latency - AC6i: 48_3_gr	GMAP/UGG/MXLT/BV-31-C
GMAP 20/50	Low Latency Streaming - AC6i: 48_4_gr	GMAP/UGG/LLU/BV-04-C
GMAP 20/50 AND GMAP 15/1	Audio In to SDU Sync Latency - AC6i: 48_4_gr	GMAP/UGG/MXLT/BV-32-C
GMAP 20/51	Low Latency Streaming - AC6ii: 32_1_gr	GMAP/UGG/LLU/BV-75-C
GMAP 20/51 AND GMAP 15/1	Audio In to SDU Sync Latency - AC6ii: 32_1_gr	GMAP/UGG/MXLT/BV-67-C
GMAP 20/52	Low Latency Streaming - AC6ii: 32_2_gr	GMAP/UGG/LLU/BV-76-C
GMAP 20/52 AND GMAP 15/1	Audio In to SDU Sync Latency - AC6ii: 32_2_gr	GMAP/UGG/MXLT/BV-68-C
GMAP 20/53	Low Latency Streaming - AC6ii: 48_1_gr	GMAP/UGG/LLU/BV-05-C
GMAP 20/53 AND GMAP 15/1	Audio In to SDU Sync Latency - AC6ii: 48_1_gr	GMAP/UGG/MXLT/BV-33-C
GMAP 20/54	Low Latency Streaming - AC6ii: 48_2_gr	GMAP/UGG/LLU/BV-06-C
GMAP 20/54 AND GMAP 15/1	Audio In to SDU Sync Latency - AC6ii: 48_2_gr	GMAP/UGG/MXLT/BV-34-C
GMAP 20/55	Low Latency Streaming - AC6ii: 48_3_gr	GMAP/UGG/LLU/BV-07-C
GMAP 20/55 AND GMAP 15/1	Audio In to SDU Sync Latency - AC6ii: 48_3_gr	GMAP/UGG/MXLT/BV-35-C
GMAP 20/56	Low Latency Streaming - AC6ii: 48_4_gr	GMAP/UGG/LLU/BV-08-C
GMAP 20/56 AND GMAP 15/1	Audio In to SDU Sync Latency - AC6ii: 48_4_gr	GMAP/UGG/MXLT/BV-36-C
GMAP 20/13	Low Latency Streaming - AC3: 32_1_gr, 16_1_gs	GMAP/UGG/LLU/BV-89-C
GMAP 20/13 AND GMAP 15/1	Audio In to SDU Sync Latency - AC3: 32_1_gr, 16_1_gs	GMAP/UGG/MXLT/BV-128-C
GMAP 20/13 AND GMAP 15/2	SDU Sync to Audio Out Latency - AC3: 32_1_gr, 16_1_gs	GMAP/UGG/MXLT/BV-150-C
GMAP 20/13 AND (NOT GMAP 15/1 OR NOT GMAP 15/2)	UGG Combined Latencies - AC3: 32_1_gr, 16_1_gs	GMAP/UGG/MXLT/BV-220-C

Item	Feature	Test Case(s)
GMAP 20/14	Low Latency Streaming - AC3: 32_2_gr, 16_2_gs	GMAP/UGG/LLU/BV-90-C
GMAP 20/14 AND GMAP 15/1	Audio In to SDU Sync Latency - AC3: 32_2_gr, 16_2_gs	GMAP/UGG/MXLT/BV-129-C
GMAP 20/14 AND GMAP 15/2	SDU Sync to Audio Out Latency - AC3: 32_2_gr, 16_2_gs	GMAP/UGG/MXLT/BV-151-C
GMAP 20/14 AND (NOT GMAP 15/1 OR NOT GMAP 15/2)	UGG Combined Latencies - AC3: 32_2_gr, 16_2_gs	GMAP/UGG/MXLT/BV-221-C
GMAP 20/15	Low Latency Streaming - AC3: 48_1_gr, 16_1_gs	GMAP/UGG/LLU/BV-91-C
GMAP 20/15 AND GMAP 15/1	Audio In to SDU Sync Latency - AC3: 48_1_gr, 16_1_gs	GMAP/UGG/MXLT/BV-130-C
GMAP 20/15 AND GMAP 15/2	SDU Sync to Audio Out Latency - AC3: 48_1_gr, 16_1_gs	GMAP/UGG/MXLT/BV-152-C
GMAP 20/15 AND (NOT GMAP 15/1 OR NOT GMAP 15/2)	UGG Combined Latencies - AC3: 48_1_gr, 16_1_gs	GMAP/UGG/MXLT/BV-222-C
GMAP 20/16	Low Latency Streaming - AC3: 48_2_gr, 16_2_gs	GMAP/UGG/LLU/BV-92-C
GMAP 20/16 AND GMAP 15/1	Audio In to SDU Sync Latency - AC3: 48_2_gr, 16_2_gs	GMAP/UGG/MXLT/BV-131-C
GMAP 20/16 AND GMAP 15/2	SDU Sync to Audio Out Latency - AC3: 48_2_gr, 16_2_gs	GMAP/UGG/MXLT/BV-153-C
GMAP 20/16 AND (NOT GMAP 15/1 OR NOT GMAP 15/2)	UGG Combined Latencies - AC3: 48_2_gr, 16_2_gs	GMAP/UGG/MXLT/BV-223-C
GMAP 20/17	Low Latency Streaming - AC3: 32_1_gr, 32_1_gs	GMAP/UGG/LLU/BV-65-C
GMAP 20/17 AND GMAP 15/1	Audio In to SDU Sync Latency - AC3: 32_1_gr, 32_1_gs	GMAP/UGG/MXLT/BV-57-C
GMAP 20/17 AND GMAP 15/2	SDU Sync to Audio Out Latency - AC3: 32_1_gr, 32_1_gs	GMAP/UGG/MXLT/BV-84-C
GMAP 20/17 AND (NOT GMAP 15/1 OR NOT GMAP 15/2)	UGG Combined Latencies - AC3: 32_1_gr, 32_1_gs	GMAP/UGG/MXLT/BV-224-C
GMAP 20/18	Low Latency Streaming - AC3: 32_2_gr, 32_2_gs	GMAP/UGG/LLU/BV-66-C
GMAP 20/18 AND GMAP 15/1	Audio In to SDU Sync Latency - AC3: 32_2_gr, 32_2_gs	GMAP/UGG/MXLT/BV-58-C
GMAP 20/18 AND GMAP 15/2	SDU Sync to Audio Out Latency - AC3: 32_2_gr, 32_2_gs	GMAP/UGG/MXLT/BV-85-C
GMAP 20/18 AND (NOT GMAP 15/1 OR NOT GMAP 15/2)	UGG Combined Latencies - AC3: 32_2_gr, 32_2_gs	GMAP/UGG/MXLT/BV-225-C
GMAP 20/19	Low Latency Streaming - AC3: 48_1_gr, 32_1_gs	GMAP/UGG/LLU/BV-09-C

Item	Feature	Test Case(s)
GMAP 20/19 AND GMAP 15/1	Audio In to SDU Sync Latency - AC3: 48_1_gr, 32_1_gs	GMAP/UGG/MXLT/BV-01-C
GMAP 20/19 AND GMAP 15/2	SDU Sync to Audio Out Latency - AC3: 48_1_gr, 32_1_gs	GMAP/UGG/MXLT/BV-86-C
GMAP 20/19 AND (NOT GMAP 15/1 OR NOT GMAP 15/2)	UGG Combined Latencies - AC3: 48_1_gr, 32_1_gs	GMAP/UGG/MXLT/BV-226-C
GMAP 20/20	Low Latency Streaming - AC3: 48_2_gr, 32_2_gs	GMAP/UGG/LLU/BV-10-C
GMAP 20/20 AND GMAP 15/1	Audio In to SDU Sync Latency - AC3: 48_2_gr, 32_2_gs	GMAP/UGG/MXLT/BV-02-C
GMAP 20/20 AND GMAP 15/2	SDU Sync to Audio Out Latency - AC3: 48_2_gr, 32_2_gs	GMAP/UGG/MXLT/BV-87-C
GMAP 20/20 AND (NOT GMAP 15/1 OR NOT GMAP 15/2)	UGG Combined Latencies - AC3: 48_2_gr, 32_2_gs	GMAP/UGG/MXLT/BV-227-C
GMAP 20/21	Low Latency Streaming - AC3: 48_1_gr, 48_1_gs	GMAP/UGG/LLU/BV-11-C
GMAP 20/21 AND GMAP 15/1	Audio In to SDU Sync Latency - AC3: 48_1_gr, 48_1_gs	GMAP/UGG/MXLT/BV-45-C
GMAP 20/21 AND GMAP 15/2	SDU Sync to Audio Out Latency - AC3: 48_1_gr, 48_1_gs	GMAP/UGG/MXLT/BV-88-C
GMAP 20/21 AND (NOT GMAP 15/1 OR NOT GMAP 15/2)	UGG Combined Latencies - AC3: 48_1_gr, 48_1_gs	GMAP/UGG/MXLT/BV-228-C
GMAP 20/22	Low Latency Streaming - AC3: 48_2_gr, 48_2_gs	GMAP/UGG/LLU/BV-12-C
GMAP 20/22 AND GMAP 15/1	Audio In to SDU Sync Latency - AC3: 48_2_gr, 48_2_gs	GMAP/UGG/MXLT/BV-46-C
GMAP 20/22 AND GMAP 15/2	SDU Sync to Audio Out Latency - AC3: 48_2_gr, 48_2_gs	GMAP/UGG/MXLT/BV-89-C
GMAP 20/22 AND (NOT GMAP 15/1 OR NOT GMAP 15/2)	UGG Combined Latencies - AC3: 48_2_gr, 48_2_gs	GMAP/UGG/MXLT/BV-229-C
GMAP 20/23	Low Latency Streaming - AC3: 48_3_gr, 32_1_gs	GMAP/UGG/LLU/BV-13-C
GMAP 20/23 AND GMAP 15/1	Audio In to SDU Sync Latency - AC3: 48_3_gr, 32_1_gs	GMAP/UGG/MXLT/BV-03-C
GMAP 20/23 AND GMAP 15/2	SDU Sync to Audio Out Latency - AC3: 48_3_gr, 32_1_gs	GMAP/UGG/MXLT/BV-90-C
GMAP 20/23 AND (NOT GMAP 15/1 OR NOT GMAP 15/2)	UGG Combined Latencies - AC3: 48_3_gr, 32_1_gs	GMAP/UGG/MXLT/BV-230-C
GMAP 20/24	Low Latency Streaming - AC3: 48_4_gr, 32_2_gs	GMAP/UGG/LLU/BV-14-C
GMAP 20/24 AND GMAP 15/1	Audio In to SDU Sync Latency - AC3: 48_4_gr, 32_2_gs	GMAP/UGG/MXLT/BV-04-C

Item	Feature	Test Case(s)
GMAP 20/24 AND GMAP 15/2	SDU Sync to Audio Out Latency - AC3: 48_4_gr, 32_2_gs	GMAP/UGG/MXLT/BV-91-C
GMAP 20/24 AND (NOT GMAP 15/1 OR NOT GMAP 15/2)	UGG Combined Latencies - AC3: 48_4_gr, 32_2_gs	GMAP/UGG/MXLT/BV-231-C
GMAP 20/25	Low Latency Streaming - AC3: 48_3_gr, 48_1_gs	GMAP/UGG/LLU/BV-67-C
GMAP 20/25 AND GMAP 15/1	Audio In to SDU Sync Latency - AC3: 48_3_gr, 48_1_gs	GMAP/UGG/MXLT/BV-59-C
GMAP 20/25 AND GMAP 15/2	SDU Sync to Audio Out Latency - AC3: 48_3_gr, 48_1_gs	GMAP/UGG/MXLT/BV-92-C
GMAP 20/25 AND (NOT GMAP 15/1 OR NOT GMAP 15/2)	UGG Combined Latencies - AC3: 48_3_gr, 48_1_gs	GMAP/UGG/MXLT/BV-232-C
GMAP 20/26	Low Latency Streaming - AC3: 48_4_gr, 48_2_gs	GMAP/UGG/LLU/BV-68-C
GMAP 20/26 AND GMAP 15/1	Audio In to SDU Sync Latency - AC3: 48_4_gr, 48_2_gs	GMAP/UGG/MXLT/BV-60-C
GMAP 20/26 AND GMAP 15/2	SDU Sync to Audio Out Latency - AC3: 48_4_gr, 48_2_gs	GMAP/UGG/MXLT/BV-93-C
GMAP 20/26 AND (NOT GMAP 15/1 OR NOT GMAP 15/2)	UGG Combined Latencies - AC3: 48_4_gr, 48_2_gs	GMAP/UGG/MXLT/BV-233-C
GMAP 20/33	Low Latency Streaming - AC5: 32_1_gr, 16_1_gs	GMAP/UGG/LLU/BV-93-C
GMAP 20/33 AND GMAP 15/1	Audio In to SDU Sync Latency - AC5: 32_1_gr, 16_1_gs	GMAP/UGG/MXLT/BV-132-C
GMAP 20/33 AND GMAP 15/2	SDU Sync to Audio Out Latency - AC5: 32_1_gr, 16_1_gs	GMAP/UGG/MXLT/BV-154-C
GMAP 20/33 AND (NOT GMAP 15/1 OR NOT GMAP 15/2)	UGG Combined Latencies - AC5: 32_1_gr, 16_1_gs	GMAP/UGG/MXLT/BV-234-C
GMAP 20/34	Low Latency Streaming - AC5: 32_2_gr, 16_2_gs	GMAP/UGG/LLU/BV-94-C
GMAP 20/34 AND GMAP 15/1	Audio In to SDU Sync Latency - AC5: 32_2_gr, 16_2_gs	GMAP/UGG/MXLT/BV-133-C
GMAP 20/34 AND GMAP 15/2	SDU Sync to Audio Out Latency - AC5: 32_2_gr, 16_2_gs	GMAP/UGG/MXLT/BV-155-C
GMAP 20/34 AND (NOT GMAP 15/1 OR NOT GMAP 15/2)	UGG Combined Latencies - AC5: 32_2_gr, 16_2_gs	GMAP/UGG/MXLT/BV-235-C
GMAP 20/35	Low Latency Streaming - AC5: 48_1_gr, 16_1_gs	GMAP/UGG/LLU/BV-95-C
GMAP 20/35 AND GMAP 15/1	Audio In to SDU Sync Latency - AC5: 48_1_gr, 16_1_gs	GMAP/UGG/MXLT/BV-134-C
GMAP 20/35 AND GMAP 15/2	SDU Sync to Audio Out Latency - AC5: 48_1_gr, 16_1_gs	GMAP/UGG/MXLT/BV-156-C

Item	Feature	Test Case(s)
GMAP 20/35 AND (NOT GMAP 15/1 OR NOT GMAP 15/2)	UGG Combined Latencies - AC5: 48_1_gr, 16_1_gs	GMAP/UGG/MXLT/BV-236-C
GMAP 20/36	Low Latency Streaming - AC5: 48_2_gr, 16_2_gs	GMAP/UGG/LLU/BV-96-C
GMAP 20/36 AND GMAP 15/1	Audio In to SDU Sync Latency - AC5: 48_2_gr, 16_2_gs	GMAP/UGG/MXLT/BV-135-C
GMAP 20/36 AND GMAP 15/2	SDU Sync to Audio Out Latency - AC5: 48_2_gr, 16_2_gs	GMAP/UGG/MXLT/BV-157-C
GMAP 20/36 AND (NOT GMAP 15/1 OR NOT GMAP 15/2)	UGG Combined Latencies - AC5: 48_2_gr, 16_2_gs	GMAP/UGG/MXLT/BV-237-C
GMAP 20/37	Low Latency Streaming - AC5: 32_1_gr, 32_1_gs	GMAP/UGG/LLU/BV-71-C
GMAP 20/37 AND GMAP 15/1	Audio In to SDU Sync Latency - AC5: 32_1_gr, 32_1_gs	GMAP/UGG/MXLT/BV-63-C
GMAP 20/37 AND GMAP 15/2	SDU Sync to Audio Out Latency - AC5: 32_1_gr, 32_1_gs	GMAP/UGG/MXLT/BV-94-C
GMAP 20/37 AND (NOT GMAP 15/1 OR NOT GMAP 15/2)	UGG Combined Latencies - AC5: 32_1_gr, 32_1_gs	GMAP/UGG/MXLT/BV-238-C
GMAP 20/38	Low Latency Streaming - AC5: 32_2_gr, 32_2_gs	GMAP/UGG/LLU/BV-72-C
GMAP 20/38 AND GMAP 15/1	Audio In to SDU Sync Latency - AC5: 32_2_gr, 32_2_gs	GMAP/UGG/MXLT/BV-64-C
GMAP 20/38 AND GMAP 15/2	SDU Sync to Audio Out Latency - AC5: 32_2_gr, 32_2_gs	GMAP/UGG/MXLT/BV-95-C
GMAP 20/38 AND (NOT GMAP 15/1 OR NOT GMAP 15/2)	UGG Combined Latencies - AC5: 32_2_gr, 32_2_gs	GMAP/UGG/MXLT/BV-239-C
GMAP 20/39	Low Latency Streaming - AC5: 48_1_gr, 32_1_gs	GMAP/UGG/LLU/BV-15-C
GMAP 20/39 AND GMAP 15/1	Audio In to SDU Sync Latency - AC5: 48_1_gr, 32_1_gs	GMAP/UGG/MXLT/BV-05-C
GMAP 20/39 AND GMAP 15/2	SDU Sync to Audio Out Latency - AC5: 48_1_gr, 32_1_gs	GMAP/UGG/MXLT/BV-96-C
GMAP 20/39 AND (NOT GMAP 15/1 OR NOT GMAP 15/2)	UGG Combined Latencies - AC5: 48_1_gr, 32_1_gs	GMAP/UGG/MXLT/BV-240-C
GMAP 20/40	Low Latency Streaming - AC5: 48_2_gr, 32_2_gs	GMAP/UGG/LLU/BV-16-C
GMAP 20/40 AND GMAP 15/1	Audio In to SDU Sync Latency - AC5: 48_2_gr, 32_2_gs	GMAP/UGG/MXLT/BV-06-C
GMAP 20/40 AND GMAP 15/2	SDU Sync to Audio Out Latency - AC5: 48_2_gr, 32_2_gs	GMAP/UGG/MXLT/BV-97-C
GMAP 20/40 AND (NOT GMAP 15/1 OR NOT GMAP 15/2)	UGG Combined Latencies - AC5: 48_2_gr, 32_2_gs	GMAP/UGG/MXLT/BV-241-C

Item	Feature	Test Case(s)
GMAP 20/41	Low Latency Streaming - AC5: 48_1_gr, 48_1_gs	GMAP/UGG/LLU/BV-17-C
GMAP 20/41 AND GMAP 15/1	Audio In to SDU Sync Latency - AC5: 48_1_gr, 48_1_gs	GMAP/UGG/MXLT/BV-47-C
GMAP 20/41 AND GMAP 15/2	SDU Sync to Audio Out Latency - AC5: 48_1_gr, 48_1_gs	GMAP/UGG/MXLT/BV-98-C
GMAP 20/41 AND (NOT GMAP 15/1 OR NOT GMAP 15/2)	UGG Combined Latencies - AC5: 48_1_gr, 48_1_gs	GMAP/UGG/MXLT/BV-242-C
GMAP 20/42	Low Latency Streaming - AC5: 48_2_gr, 48_2_gs	GMAP/UGG/LLU/BV-18-C
GMAP 20/42 AND GMAP 15/1	Audio In to SDU Sync Latency - AC5: 48_2_gr, 48_2_gs	GMAP/UGG/MXLT/BV-48-C
GMAP 20/42 AND GMAP 15/2	SDU Sync to Audio Out Latency - AC5: 48_2_gr, 48_2_gs	GMAP/UGG/MXLT/BV-99-C
GMAP 20/42 AND (NOT GMAP 15/1 OR NOT GMAP 15/2)	UGG Combined Latencies - AC5: 48_2_gr, 48_2_gs	GMAP/UGG/MXLT/BV-243-C
GMAP 20/43	Low Latency Streaming - AC5: 48_3_gr, 32_1_gs	GMAP/UGG/LLU/BV-19-C
GMAP 20/43 AND GMAP 15/1	Audio In to SDU Sync Latency - AC5: 48_3_gr, 32_1_gs	GMAP/UGG/MXLT/BV-07-C
GMAP 20/43 AND GMAP 15/2	SDU Sync to Audio Out Latency - AC5: 48_3_gr, 32_1_gs	GMAP/UGG/MXLT/BV-100-C
GMAP 20/43 AND (NOT GMAP 15/1 OR NOT GMAP 15/2)	UGG Combined Latencies - AC5: 48_3_gr, 32_1_gs	GMAP/UGG/MXLT/BV-244-C
GMAP 20/44	Low Latency Streaming - AC5: 48_4_gr, 32_2_gs	GMAP/UGG/LLU/BV-20-C
GMAP 20/44 AND GMAP 15/1	Audio In to SDU Sync Latency - AC5: 48_4_gr, 32_2_gs	GMAP/UGG/MXLT/BV-08-C
GMAP 20/44 AND GMAP 15/2	SDU Sync to Audio Out Latency - AC5: 48_4_gr, 32_2_gs	GMAP/UGG/MXLT/BV-101-C
GMAP 20/44 AND (NOT GMAP 15/1 OR NOT GMAP 15/2)	UGG Combined Latencies - AC5: 48_4_gr, 32_2_gs	GMAP/UGG/MXLT/BV-245-C
GMAP 20/57	Low Latency Streaming - AC7ii: 32_1_gr, 16_1_gs	GMAP/UGG/LLU/BV-97-C
GMAP 20/57 AND GMAP 15/1	Audio In to SDU Sync Latency - AC7ii: 32_1_gr, 16_1_gs	GMAP/UGG/MXLT/BV-136-C
GMAP 20/57 AND GMAP 15/2	SDU Sync to Audio Out Latency - AC7ii: 32_1_gr, 16_1_gs	GMAP/UGG/MXLT/BV-158-C
GMAP 20/57 AND (NOT GMAP 15/1 OR NOT GMAP 15/2)	UGG Combined Latencies - AC7ii: 32_1_gr, 16_1_gs	GMAP/UGG/MXLT/BV-246-C
GMAP 20/58	Low Latency Streaming - AC7ii: 32_2_gr, 16_2_gs	GMAP/UGG/LLU/BV-98-C

Item	Feature	Test Case(s)
GMAP 20/58 AND GMAP 15/1	Audio In to SDU Sync Latency - AC7ii: 32_2_gr, 16_2_gs	GMAP/UGG/MXLT/BV-137-C
GMAP 20/58 AND GMAP 15/2	SDU Sync to Audio Out Latency - AC7ii: 32_2_gr, 16_2_gs	GMAP/UGG/MXLT/BV-159-C
GMAP 20/58 AND (NOT GMAP 15/1 OR NOT GMAP 15/2)	UGG Combined Latencies - AC7ii: 32_2_gr, 16_2_gs	GMAP/UGG/MXLT/BV-247-C
GMAP 20/59	Low Latency Streaming - AC7ii: 48_1_gr, 16_1_gs	GMAP/UGG/LLU/BV-99-C
GMAP 20/59 AND GMAP 15/1	Audio In to SDU Sync Latency - AC7ii: 48_1_gr, 16_1_gs	GMAP/UGG/MXLT/BV-138-C
GMAP 20/59 AND GMAP 15/2	SDU Sync to Audio Out Latency - AC7ii: 48_1_gr, 16_1_gs	GMAP/UGG/MXLT/BV-160-C
GMAP 20/59 AND (NOT GMAP 15/1 OR NOT GMAP 15/2)	UGG Combined Latencies - AC7ii: 48_1_gr, 16_1_gs	GMAP/UGG/MXLT/BV-248-C
GMAP 20/60	Low Latency Streaming - AC7ii: 48_2_gr, 16_2_gs	GMAP/UGG/LLU/BV-100-C
GMAP 20/60 AND GMAP 15/1	Audio In to SDU Sync Latency - AC7ii: 48_2_gr, 16_2_gs	GMAP/UGG/MXLT/BV-139-C
GMAP 20/60 AND GMAP 15/2	SDU Sync to Audio Out Latency - AC7ii: 48_2_gr, 16_2_gs	GMAP/UGG/MXLT/BV-161-C
GMAP 20/60 AND (NOT GMAP 15/1 OR NOT GMAP 15/2)	UGG Combined Latencies - AC7ii: 48_2_gr, 16_2_gs	GMAP/UGG/MXLT/BV-249-C
GMAP 20/61	Low Latency Streaming - AC7ii: 32_1_gr, 32_1_gs	GMAP/UGG/LLU/BV-41-C
GMAP 20/61 AND GMAP 15/1	Audio In to SDU Sync Latency - AC7ii: 32_1_gr, 32_1_gs	GMAP/UGG/MXLT/BV-69-C
GMAP 20/61 AND GMAP 15/2	SDU Sync to Audio Out Latency - AC7ii: 32_1_gr, 32_1_gs	GMAP/UGG/MXLT/BV-102-C
GMAP 20/61 AND (NOT GMAP 15/1 OR NOT GMAP 15/2)	UGG Combined Latencies - AC7ii: 32_1_gr, 32_1_gs	GMAP/UGG/MXLT/BV-250-C
GMAP 20/62	Low Latency Streaming - AC7ii: 32_2_gr, 32_2_gs	GMAP/UGG/LLU/BV-42-C
GMAP 20/62 AND GMAP 15/1	Audio In to SDU Sync Latency - AC7ii: 32_2_gr, 32_2_gs	GMAP/UGG/MXLT/BV-70-C
GMAP 20/62 AND GMAP 15/2	SDU Sync to Audio Out Latency - AC7ii: 32_2_gr, 32_2_gs	GMAP/UGG/MXLT/BV-103-C
GMAP 20/62 AND (NOT GMAP 15/1 OR NOT GMAP 15/2)	UGG Combined Latencies - AC7ii: 32_2_gr, 32_2_gs	GMAP/UGG/MXLT/BV-251-C
GMAP 20/63	Low Latency Streaming - AC7ii: 48_1_gr, 32_1_gs	GMAP/UGG/LLU/BV-21-C
GMAP 20/63 AND GMAP 15/1	Audio In to SDU Sync Latency - AC7ii: 48_1_gr, 32_1_gs	GMAP/UGG/MXLT/BV-09-C

Item	Feature	Test Case(s)
GMAP 20/63 AND GMAP 15/2	SDU Sync to Audio Out Latency - AC7ii: 48_1_gr, 32_1_gs	GMAP/UGG/MXLT/BV-104-C
GMAP 20/63 AND (NOT GMAP 15/1 OR NOT GMAP 15/2)	UGG Combined Latencies - AC7ii: 48_1_gr, 32_1_gs	GMAP/UGG/MXLT/BV-252-C
GMAP 20/64	Low Latency Streaming and Max Latency - AC7ii: 48_2_gr, 32_2_gs	GMAP/UGG/LLU/BV-22-C
GMAP 20/64 AND GMAP 15/1	Audio In to SDU Sync Latency - AC7ii: 48_2_gr, 32_2_gs	GMAP/UGG/MXLT/BV-10-C
GMAP 20/64 AND GMAP 15/2	SDU Sync to Audio Out Latency - AC7ii: 48_2_gr, 32_2_gs	GMAP/UGG/MXLT/BV-105-C
GMAP 20/64 AND (NOT GMAP 15/1 OR NOT GMAP 15/2)	UGG Combined Latencies - AC7ii: 48_2_gr, 32_2_gs	GMAP/UGG/MXLT/BV-253-C
GMAP 20/65	Low Latency Streaming - AC7ii: 48_1_gr, 48_1_gs	GMAP/UGG/LLU/BV-23-C
GMAP 20/65 AND GMAP 15/1	Audio In to SDU Sync Latency - AC7ii: 48_1_gr, 48_1_gs	GMAP/UGG/MXLT/BV-49-C
GMAP 20/65 AND GMAP 15/2	SDU Sync to Audio Out Latency - AC7ii: 48_1_gr, 48_1_gs	GMAP/UGG/MXLT/BV-106-C
GMAP 20/65 AND (NOT GMAP 15/1 OR NOT GMAP 15/2)	UGG Combined Latencies - AC7ii: 48_1_gr, 48_1_gs	GMAP/UGG/MXLT/BV-254-C
GMAP 20/66	Low Latency Streaming - AC7ii: 48_2_gr, 48_2_gs	GMAP/UGG/LLU/BV-24-C
GMAP 20/66 AND GMAP 15/1	Audio In to SDU Sync Latency - AC7ii: 48_2_gr, 48_2_gs	GMAP/UGG/MXLT/BV-50-C
GMAP 20/66 AND GMAP 15/2	SDU Sync to Audio Out Latency - AC7ii: 48_2_gr, 48_2_gs	GMAP/UGG/MXLT/BV-107-C
GMAP 20/66 AND (NOT GMAP 15/1 OR NOT GMAP 15/2)	UGG Combined Latencies - AC7ii: 48_2_gr, 48_2_gs	GMAP/UGG/MXLT/BV-255-C
GMAP 20/67	Low Latency Streaming - AC7ii: 48_3_gr, 32_1_gs	GMAP/UGG/LLU/BV-25-C
GMAP 20/67 AND GMAP 15/1	Audio In to SDU Sync Latency - AC7ii: 48_3_gr, 32_1_gs	GMAP/UGG/MXLT/BV-11-C
GMAP 20/67 AND GMAP 15/2	SDU Sync to Audio Out Latency - AC7ii: 48_3_gr, 32_1_gs	GMAP/UGG/MXLT/BV-108-C
GMAP 20/67 AND (NOT GMAP 15/1 OR NOT GMAP 15/2)	UGG Combined Latencies - AC7ii: 48_3_gr, 32_1_gs	GMAP/UGG/MXLT/BV-256-C
GMAP 20/68	Low Latency Streaming - AC7ii: 48_4_gr, 32_2_gs	GMAP/UGG/LLU/BV-26-C
GMAP 20/68 AND GMAP 15/1	Audio In to SDU Sync Latency - AC7ii: 48_4_gr, 32_2_gs	GMAP/UGG/MXLT/BV-12-C
GMAP 20/68 AND GMAP 15/2	SDU Sync to Audio Out Latency - AC7ii: 48_4_gr, 32_2_gs	GMAP/UGG/MXLT/BV-109-C

Item	Feature	Test Case(s)
GMAP 20/68 AND (NOT GMAP 15/1 OR NOT GMAP 15/2)	UGG Combined Latencies - AC7ii: 48_4_gr, 32_2_gs	GMAP/UGG/MXLT/BV-257-C
GMAP 20/69	Low Latency Streaming - AC7ii: 48_3_gr, 48_1_gs	GMAP/UGG/LLU/BV-77-C
GMAP 20/69 AND GMAP 15/1	Audio In to SDU Sync Latency - AC7ii: 48_3_gr, 48_1_gs	GMAP/UGG/MXLT/BV-71-C
GMAP 20/69 AND GMAP 15/2	SDU Sync to Audio Out Latency - AC7ii: 48_3_gr, 48_1_gs	GMAP/UGG/MXLT/BV-110-C
GMAP 20/69 AND (NOT GMAP 15/1 OR NOT GMAP 15/2)	UGG Combined Latencies - AC7ii: 48_3_gr, 48_1_gs	GMAP/UGG/MXLT/BV-258-C
GMAP 20/70	Low Latency Streaming - AC7ii: 48_4_gr, 48_2_gs	GMAP/UGG/LLU/BV-78-C
GMAP 20/70 AND GMAP 15/1	Audio In to SDU Sync Latency - AC7ii: 48_4_gr, 48_2_gs	GMAP/UGG/MXLT/BV-72-C
GMAP 20/70 AND GMAP 15/2	SDU Sync to Audio Out Latency - AC7ii: 48_4_gr, 48_2_gs	GMAP/UGG/MXLT/BV-111-C
GMAP 20/70 AND (NOT GMAP 15/1 OR NOT GMAP 15/2)	UGG Combined Latencies - AC7ii: 48_4_gr, 48_2_gs	GMAP/UGG/MXLT/BV-259-C
GMAP 20/71	Low Latency Streaming - AC8i: 32_1_gr, 16_1_gs	GMAP/UGG/LLU/BV-101-C
GMAP 20/71 AND GMAP 15/1	Audio In to SDU Sync Latency - AC8i: 32_1_gr, 16_1_gs	GMAP/UGG/MXLT/BV-140-C
GMAP 20/71 AND GMAP 15/2	SDU Sync to Audio Out Latency - AC8i: 32_1_gr, 16_1_gs	GMAP/UGG/MXLT/BV-162-C
GMAP 20/71 AND (NOT GMAP 15/1 OR NOT GMAP 15/2)	UGG Combined Latencies - AC8i: 32_1_gr, 16_1_gs	GMAP/UGG/MXLT/BV-260-C
GMAP 20/72	Low Latency Streaming - AC8i: 32_2_gr, 16_2_gs	GMAP/UGG/LLU/BV-102-C
GMAP 20/72 AND GMAP 15/1	Audio In to SDU Sync Latency - AC8i: 32_2_gr, 16_2_gs	GMAP/UGG/MXLT/BV-141-C
GMAP 20/72 AND GMAP 15/2	SDU Sync to Audio Out Latency - AC8i: 32_2_gr, 16_2_gs	GMAP/UGG/MXLT/BV-163-C
GMAP 20/72 AND (NOT GMAP 15/1 OR NOT GMAP 15/2)	UGG Combined Latencies - AC8i: 32_2_gr, 16_2_gs	GMAP/UGG/MXLT/BV-261-C
GMAP 20/73	Low Latency Streaming - AC8i: 48_1_gr, 16_1_gs	GMAP/UGG/LLU/BV-103-C
GMAP 20/73 AND GMAP 15/1	Audio In to SDU Sync Latency - AC8i: 48_1_gr, 16_1_gs	GMAP/UGG/MXLT/BV-142-C
GMAP 20/73 AND GMAP 15/2	SDU Sync to Audio Out Latency - AC8i: 48_1_gr, 16_1_gs	GMAP/UGG/MXLT/BV-164-C
GMAP 20/73 AND (NOT GMAP 15/1 OR NOT GMAP 15/2)	UGG Combined Latencies - AC8i: 48_1_gr, 16_1_gs	GMAP/UGG/MXLT/BV-262-C

Item	Feature	Test Case(s)
GMAP 20/74	Low Latency Streaming - AC8i: 48_2_gr, 16_2_gs	GMAP/UGG/LLU/BV-104-C
GMAP 20/74 AND GMAP 15/1	Audio In to SDU Sync Latency - AC8i: 48_2_gr, 16_2_gs	GMAP/UGG/MXLT/BV-143-C
GMAP 20/74 AND GMAP 15/2	SDU Sync to Audio Out Latency - AC8i: 48_2_gr, 16_2_gs	GMAP/UGG/MXLT/BV-165-C
GMAP 20/74 AND (NOT GMAP 15/1 OR NOT GMAP 15/2)	UGG Combined Latencies - AC8i: 48_2_gr, 16_2_gs	GMAP/UGG/MXLT/BV-263-C
GMAP 20/75	Low Latency Streaming - AC8i: 32_1_gr, 32_1_gs	GMAP/UGG/LLU/BV-79-C
GMAP 20/75 AND GMAP 15/1	Audio In to SDU Sync Latency - AC8i: 32_1_gr, 32_1_gs	GMAP/UGG/MXLT/BV-73-C
GMAP 20/75 AND GMAP 15/2	SDU Sync to Audio Out Latency - AC8i: 32_1_gr, 32_1_gs	GMAP/UGG/MXLT/BV-112-C
GMAP 20/75 AND (NOT GMAP 15/1 OR NOT GMAP 15/2)	UGG Combined Latencies - AC8i: 32_1_gr, 32_1_gs	GMAP/UGG/MXLT/BV-264-C
GMAP 20/76	Low Latency Streaming - AC8i: 32_2_gr, 32_2_gs	GMAP/UGG/LLU/BV-80-C
GMAP 20/76 AND GMAP 15/1	Audio In to SDU Sync Latency - AC8i: 32_2_gr, 32_2_gs	GMAP/UGG/MXLT/BV-74-C
GMAP 20/76 AND GMAP 15/2	SDU Sync to Audio Out Latency - AC8i: 32_2_gr, 32_2_gs	GMAP/UGG/MXLT/BV-113-C
GMAP 20/76 AND (NOT GMAP 15/1 OR NOT GMAP 15/2)	UGG Combined Latencies - AC8i: 32_2_gr, 32_2_gs	GMAP/UGG/MXLT/BV-265-C
GMAP 20/77	Low Latency Streaming - AC8i: 48_1_gr, 32_1_gs	GMAP/UGG/LLU/BV-27-C
GMAP 20/77 AND GMAP 15/1	Audio In to SDU Sync Latency - AC8i: 48_1_gr, 32_1_gs	GMAP/UGG/MXLT/BV-13-C
GMAP 20/77 AND GMAP 15/2	SDU Sync to Audio Out Latency - AC8i: 48_1_gr, 32_1_gs	GMAP/UGG/MXLT/BV-114-C
GMAP 20/77 AND (NOT GMAP 15/1 OR NOT GMAP 15/2)	UGG Combined Latencies - AC8i: 48_1_gr, 32_1_gs	GMAP/UGG/MXLT/BV-266-C
GMAP 20/78	Low Latency Streaming - AC8i: 48_2_gr, 32_2_gs	GMAP/UGG/LLU/BV-28-C
GMAP 20/78 AND GMAP 15/1	Audio In to SDU Sync Latency - AC8i: 48_2_gr, 32_2_gs	GMAP/UGG/MXLT/BV-14-C
GMAP 20/78 AND GMAP 15/2	SDU Sync to Audio Out Latency - AC8i: 48_2_gr, 32_2_gs	GMAP/UGG/MXLT/BV-115-C
GMAP 20/78 AND (NOT GMAP 15/1 OR NOT GMAP 15/2)	UGG Combined Latencies - AC8i: 48_2_gr, 32_2_gs	GMAP/UGG/MXLT/BV-267-C
GMAP 20/79	Low Latency Streaming - AC8i: 48_1_gr, 48_1_gs	GMAP/UGG/LLU/BV-29-C

Item	Feature	Test Case(s)
GMAP 20/79 AND GMAP 15/1	Audio In to SDU Sync Latency - AC8i: 48_1_gr, 48_1_gs	GMAP/UGG/MXLT/BV-51-C
GMAP 20/79 AND GMAP 15/2	SDU Sync to Audio Out Latency - AC8i: 48_1_gr, 48_1_gs	GMAP/UGG/MXLT/BV-116-C
GMAP 20/79 AND (NOT GMAP 15/1 OR NOT GMAP 15/2)	UGG Combined Latencies - AC8i: 48_1_gr, 48_1_gs	GMAP/UGG/MXLT/BV-268-C
GMAP 20/80	Low Latency Streaming - AC8i: 48_2_gr, 48_2_gs	GMAP/UGG/LLU/BV-30-C
GMAP 20/80 AND GMAP 15/1	Audio In to SDU Sync Latency - AC8i: 48_2_gr, 48_2_gs	GMAP/UGG/MXLT/BV-52-C
GMAP 20/80 AND GMAP 15/2	SDU Sync to Audio Out Latency - AC8i: 48_2_gr, 48_2_gs	GMAP/UGG/MXLT/BV-117-C
GMAP 20/80 AND (NOT GMAP 15/1 OR NOT GMAP 15/2)	UGG Combined Latencies - AC8i: 48_2_gr, 48_2_gs	GMAP/UGG/MXLT/BV-269-C
GMAP 20/81	Low Latency Streaming - AC8i: 48_3_gr, 32_1_gs	GMAP/UGG/LLU/BV-31-C
GMAP 20/81 AND GMAP 15/1	Audio In to SDU Sync Latency - AC8i: 48_3_gr, 32_1_gs	GMAP/UGG/MXLT/BV-15-C
GMAP 20/81 AND GMAP 15/2	SDU Sync to Audio Out Latency - AC8i: 48_3_gr, 32_1_gs	GMAP/UGG/MXLT/BV-118-C
GMAP 20/81 AND (NOT GMAP 15/1 OR NOT GMAP 15/2)	UGG Combined Latencies - AC8i: 48_3_gr, 32_1_gs	GMAP/UGG/MXLT/BV-270-C
GMAP 20/82	Low Latency Streaming - AC8i: 48_4_gr, 32_2_gs	GMAP/UGG/LLU/BV-32-C
GMAP 20/82 AND GMAP 15/1	Audio In to SDU Sync Latency - AC8i: 48_4_gr, 32_2_gs	GMAP/UGG/MXLT/BV-16-C
GMAP 20/82 AND GMAP 15/2	SDU Sync to Audio Out Latency - AC8i: 48_4_gr, 32_2_gs	GMAP/UGG/MXLT/BV-119-C
GMAP 20/82 AND (NOT GMAP 15/1 OR NOT GMAP 15/2)	UGG Combined Latencies - AC8i: 48_4_gr, 32_2_gs	GMAP/UGG/MXLT/BV-271-C
GMAP 20/83	Low Latency Streaming - AC8ii: 32_1_gr, 16_1_gs	GMAP/UGG/LLU/BV-105-C
GMAP 20/83 AND GMAP 15/1	Audio In to SDU Sync Latency - AC8ii: 32_1_gr, 16_1_gs	GMAP/UGG/MXLT/BV-144-C
GMAP 20/83 AND GMAP 15/2	SDU Sync to Audio Out Latency - AC8ii: 32_1_gr, 16_1_gs	GMAP/UGG/MXLT/BV-166-C
GMAP 20/83 AND (NOT GMAP 15/1 OR NOT GMAP 15/2)	UGG Combined Latencies - AC8ii: 32_1_gr, 16_1_gs	GMAP/UGG/MXLT/BV-272-C
GMAP 20/84	Low Latency Streaming - AC8ii: 32_2_gr, 16_2_gs	GMAP/UGG/LLU/BV-106-C
GMAP 20/84 AND GMAP 15/1	Audio In to SDU Sync Latency - AC8ii: 32_2_gr, 16_2_gs	GMAP/UGG/MXLT/BV-145-C

Item	Feature	Test Case(s)
GMAP 20/84 AND GMAP 15/2	SDU Sync to Audio Out Latency - AC8ii: 32_2_gr, 16_2_gs	GMAP/UGG/MXLT/BV-167-C
GMAP 20/84 AND (NOT GMAP 15/1 OR NOT GMAP 15/2)	UGG Combined Latencies - AC8ii: 32_2_gr, 16_2_gs	GMAP/UGG/MXLT/BV-273-C
GMAP 20/85	Low Latency Streaming - AC8ii: 48_1_gr, 16_1_gs	GMAP/UGG/LLU/BV-107-C
GMAP 20/85 AND GMAP 15/1	Audio In to SDU Sync Latency - AC8ii: 48_1_gr, 16_1_gs	GMAP/UGG/MXLT/BV-146-C
GMAP 20/85 AND GMAP 15/2	SDU Sync to Audio Out Latency - AC8ii: 48_1_gr, 16_1_gs	GMAP/UGG/MXLT/BV-168-C
GMAP 20/85 AND (NOT GMAP 15/1 OR NOT GMAP 15/2)	UGG Combined Latencies - AC8ii: 48_1_gr, 16_1_gs	GMAP/UGG/MXLT/BV-274-C
GMAP 20/86	Low Latency Streaming - AC8ii: 48_2_gr, 16_2_gs	GMAP/UGG/LLU/BV-108-C
GMAP 20/86 AND GMAP 15/1	Audio In to SDU Sync Latency - AC8ii: 48_2_gr, 16_2_gs	GMAP/UGG/MXLT/BV-147-C
GMAP 20/86 AND GMAP 15/2	SDU Sync to Audio Out Latency - AC8ii: 48_2_gr, 16_2_gs	GMAP/UGG/MXLT/BV-169-C
GMAP 20/86 AND (NOT GMAP 15/1 OR NOT GMAP 15/2)	UGG Combined Latencies - AC8ii: 48_2_gr, 16_2_gs	GMAP/UGG/MXLT/BV-275-C
GMAP 20/87	Low Latency Streaming - AC8ii: 32_1_gr, 32_1_gs	GMAP/UGG/LLU/BV-81-C
GMAP 20/87 AND GMAP 15/1	Audio In to SDU Sync Latency - AC8ii: 32_1_gr, 32_1_gs	GMAP/UGG/MXLT/BV-75-C
GMAP 20/87 AND GMAP 15/2	SDU Sync to Audio Out Latency - AC8ii: 32_1_gr, 32_1_gs	GMAP/UGG/MXLT/BV-120-C
GMAP 20/87 AND (NOT GMAP 15/1 OR NOT GMAP 15/2)	UGG Combined Latencies - AC8ii: 32_1_gr, 32_1_gs	GMAP/UGG/MXLT/BV-276-C
GMAP 20/88	Low Latency Streaming - AC8ii: 32_2_gr, 32_2_gs	GMAP/UGG/LLU/BV-82-C
GMAP 20/88 AND GMAP 15/1	Audio In to SDU Sync Latency - AC8ii: 32_2_gr, 32_2_gs	GMAP/UGG/MXLT/BV-76-C
GMAP 20/88 AND GMAP 15/2	SDU Sync to Audio Out Latency - AC8ii: 32_2_gr, 32_2_gs	GMAP/UGG/MXLT/BV-121-C
GMAP 20/88 AND (NOT GMAP 15/1 OR NOT GMAP 15/2)	UGG Combined Latencies - AC8ii: 32_2_gr, 32_2_gs	GMAP/UGG/MXLT/BV-277-C
GMAP 20/89	Low Latency Streaming - AC8ii: 48_1_gr, 32_1_gs	GMAP/UGG/LLU/BV-33-C
GMAP 20/89 AND GMAP 15/1	Audio In to SDU Sync Latency - AC8ii: 48_1_gr, 32_1_gs	GMAP/UGG/MXLT/BV-17-C
GMAP 20/89 AND GMAP 15/2	SDU Sync to Audio Out Latency - AC8ii: 48_1_gr, 32_1_gs	GMAP/UGG/MXLT/BV-122-C

Item	Feature	Test Case(s)
GMAP 20/89 AND (NOT GMAP 15/1 OR NOT GMAP 15/2)	UGG Combined Latencies - AC8ii: 48_1_gr, 32_1_gs	GMAP/UGG/MXLT/BV-278-C
GMAP 20/90	Low Latency Streaming - AC8ii: 48_2_gr, 32_2_gs	GMAP/UGG/LLU/BV-34-C
GMAP 20/90 AND GMAP 15/1	Audio In to SDU Sync Latency - AC8ii: 48_2_gr, 32_2_gs	GMAP/UGG/MXLT/BV-18-C
GMAP 20/90 AND GMAP 15/2	SDU Sync to Audio Out Latency - AC8ii: 48_2_gr, 32_2_gs	GMAP/UGG/MXLT/BV-123-C
GMAP 20/90 AND (NOT GMAP 15/1 OR NOT GMAP 15/2)	UGG Combined Latencies - AC8ii: 48_2_gr, 32_2_gs	GMAP/UGG/MXLT/BV-279-C
GMAP 20/91	Low Latency Streaming - AC8ii: 48_1_gr, 48_1_gs	GMAP/UGG/LLU/BV-35-C
GMAP 20/91 AND GMAP 15/1	Audio In to SDU Sync Latency - AC8ii: 48_1_gr, 48_1_gs	GMAP/UGG/MXLT/BV-53-C
GMAP 20/91 AND GMAP 15/2	SDU Sync to Audio Out Latency - AC8ii: 48_1_gr, 48_1_gs	GMAP/UGG/MXLT/BV-124-C
GMAP 20/91 AND (NOT GMAP 15/1 OR NOT GMAP 15/2)	UGG Combined Latencies - AC8ii: 48_1_gr, 48_1_gs	GMAP/UGG/MXLT/BV-280-C
GMAP 20/92	Low Latency Streaming - AC8ii: 48_2_gr, 48_2_gs	GMAP/UGG/LLU/BV-36-C
GMAP 20/92 AND GMAP 15/1	Audio In to SDU Sync Latency - AC8ii: 48_2_gr, 48_2_gs	GMAP/UGG/MXLT/BV-54-C
GMAP 20/92 AND GMAP 15/2	SDU Sync to Audio Out Latency - AC8ii: 48_2_gr, 48_2_gs	GMAP/UGG/MXLT/BV-125-C
GMAP 20/92 AND (NOT GMAP 15/1 OR NOT GMAP 15/2)	UGG Combined Latencies - AC8ii: 48_2_gr, 48_2_gs	GMAP/UGG/MXLT/BV-281-C
GMAP 20/93	Low Latency Streaming - AC8ii: 48_3_gr, 32_1_gs	GMAP/UGG/LLU/BV-37-C
GMAP 20/93 AND GMAP 15/1	Audio In to SDU Sync Latency - AC8ii: 48_3_gr, 32_1_gs	GMAP/UGG/MXLT/BV-19-C
GMAP 20/93 AND GMAP 15/2	SDU Sync to Audio Out Latency - AC8ii: 48_3_gr, 32_1_gs	GMAP/UGG/MXLT/BV-126-C
GMAP 20/93 AND (NOT GMAP 15/1 OR NOT GMAP 15/2)	UGG Combined Latencies - AC8ii: 48_3_gr, 32_1_gs	GMAP/UGG/MXLT/BV-282-C
GMAP 20/94	Low Latency Streaming - AC8ii: 48_4_gr, 32_2_gs	GMAP/UGG/LLU/BV-38-C
GMAP 20/94 AND GMAP 15/1	Audio In to SDU Sync Latency - AC8ii: 48_4_gr, 32_2_gs	GMAP/UGG/MXLT/BV-20-C
GMAP 20/94 AND GMAP 15/2	SDU Sync to Audio Out Latency - AC8ii: 48_4_gr, 32_2_gs	GMAP/UGG/MXLT/BV-127-C
GMAP 20/94 AND (NOT GMAP 15/1 OR NOT GMAP 15/2)	UGG Combined Latencies - AC8ii: 48_4_gr, 32_2_gs	GMAP/UGG/MXLT/BV-283-C

Item	Feature	Test Case(s)
GMAP 20/95	Low Latency Streaming - AC11i: 32_1_gr, 16_1_gs	GMAP/UGG/LLU/BV-109-C
GMAP 20/95 AND GMAP 15/1	Audio In to SDU Sync Latency - AC11i: 32_1_gr, 16_1_gs	GMAP/UGG/MXLT/BV-170-C
GMAP 20/95 AND GMAP 15/2	SDU Sync to Audio Out Latency - AC11i: 32_1_gr, 16_1_gs	GMAP/UGG/MXLT/BV-190-C
GMAP 20/95 AND (NOT GMAP 15/1 OR NOT GMAP 15/2)	UGG Combined Latencies - AC11i: 32_1_gr, 16_1_gs	GMAP/UGG/MXLT/BV-284-C
GMAP 20/96	Low Latency Streaming - AC11i: 32_2_gr, 16_2_gs	GMAP/UGG/LLU/BV-110-C
GMAP 20/96 AND GMAP 15/1	Audio In to SDU Sync Latency - AC11i: 32_2_gr, 16_2_gs	GMAP/UGG/MXLT/BV-171-C
GMAP 20/96 AND GMAP 15/2	SDU Sync to Audio Out Latency - AC11i: 32_2_gr, 16_2_gs	GMAP/UGG/MXLT/BV-191-C
GMAP 20/96 AND (NOT GMAP 15/1 OR NOT GMAP 15/2)	UGG Combined Latencies - AC11i: 32_2_gr, 16_2_gs	GMAP/UGG/MXLT/BV-285-C
GMAP 20/97	Low Latency Streaming - AC11i: 48_1_gr, 16_1_gs	GMAP/UGG/LLU/BV-111-C
GMAP 20/97 AND GMAP 15/1	Audio In to SDU Sync Latency - AC11i: 48_1_gr, 16_1_gs	GMAP/UGG/MXLT/BV-172-C
GMAP 20/97 AND GMAP 15/2	SDU Sync to Audio Out Latency - AC11i: 48_1_gr, 16_1_gs	GMAP/UGG/MXLT/BV-192-C
GMAP 20/97 AND (NOT GMAP 15/1 OR NOT GMAP 15/2)	UGG Combined Latencies - AC11i: 48_1_gr, 16_1_gs	GMAP/UGG/MXLT/BV-286-C
GMAP 20/98	Low Latency Streaming - AC11i: 48_2_gr, 16_2_gs	GMAP/UGG/LLU/BV-112-C
GMAP 20/98 AND GMAP 15/1	Audio In to SDU Sync Latency - AC11i: 48_2_gr, 16_2_gs	GMAP/UGG/MXLT/BV-173-C
GMAP 20/98 AND GMAP 15/2	SDU Sync to Audio Out Latency - AC11i: 48_2_gr, 16_2_gs	GMAP/UGG/MXLT/BV-193-C
GMAP 20/98 AND (NOT GMAP 15/1 OR NOT GMAP 15/2)	UGG Combined Latencies - AC11i: 48_2_gr, 16_2_gs	GMAP/UGG/MXLT/BV-287-C
GMAP 20/99	Low Latency Streaming - AC11i: 32_1_gr, 32_1_gs	GMAP/UGG/LLU/BV-83-C
GMAP 20/99 AND GMAP 15/1	Audio In to SDU Sync Latency - AC11i: 32_1_gr, 32_1_gs	GMAP/UGG/MXLT/BV-174-C
GMAP 20/99 AND GMAP 15/2	SDU Sync to Audio Out Latency - AC11i: 32_1_gr, 32_1_gs	GMAP/UGG/MXLT/BV-194-C
GMAP 20/99 AND (NOT GMAP 15/1 OR NOT GMAP 15/2)	UGG Combined Latencies - AC11i: 32_1_gr, 32_1_gs	GMAP/UGG/MXLT/BV-288-C
GMAP 20/100	Low Latency Streaming - AC11i: 32_2_gr, 32_2_gs	GMAP/UGG/LLU/BV-84-C

Item	Feature	Test Case(s)
GMAP 20/100 AND GMAP 15/1	Audio In to SDU Sync Latency - AC11i: 32_2_gr, 32_2_gs	GMAP/UGG/MXLT/BV-175-C
GMAP 20/100 AND GMAP 15/2	SDU Sync to Audio Out Latency - AC11i: 32_2_gr, 32_2_gs	GMAP/UGG/MXLT/BV-195-C
GMAP 20/100 AND (NOT GMAP 15/1 OR NOT GMAP 15/2)	UGG Combined Latencies - AC11i: 32_2_gr, 32_2_gs	GMAP/UGG/MXLT/BV-289-C
GMAP 20/101	Low Latency Streaming - AC11i: 48_1_gr, 32_1_gs	GMAP/UGG/LLU/BV-39-C
GMAP 20/101 AND GMAP 15/1	Audio In to SDU Sync Latency - AC11i: 48_1_gr, 32_1_gs	GMAP/UGG/MXLT/BV-176-C
GMAP 20/101 AND GMAP 15/2	SDU Sync to Audio Out Latency - AC11i: 48_1_gr, 32_1_gs	GMAP/UGG/MXLT/BV-196-C
GMAP 20/101 AND (NOT GMAP 15/1 OR NOT GMAP 15/2)	UGG Combined Latencies - AC11i: 48_1_gr, 32_1_gs	GMAP/UGG/MXLT/BV-290-C
GMAP 20/102	Low Latency Streaming - AC11i: 48_2_gr, 32_2_gs	GMAP/UGG/LLU/BV-40-C
GMAP 20/102 AND GMAP 15/1	Audio In to SDU Sync Latency - AC11i: 48_2_gr, 32_2_gs	GMAP/UGG/MXLT/BV-177-C
GMAP 20/102 AND GMAP 15/2	SDU Sync to Audio Out Latency - AC11i: 48_2_gr, 32_2_gs	GMAP/UGG/MXLT/BV-197-C
GMAP 20/102 AND (NOT GMAP 15/1 OR NOT GMAP 15/2)	UGG Combined Latencies - AC11i: 48_2_gr, 32_2_gs	GMAP/UGG/MXLT/BV-291-C
GMAP 20/103	Low Latency Streaming - AC11i: 48_3_gr, 32_1_gs	GMAP/UGG/LLU/BV-43-C
GMAP 20/103 AND GMAP 15/1	Audio In to SDU Sync Latency - AC11i: 48_3_gr, 32_1_gs	GMAP/UGG/MXLT/BV-178-C
GMAP 20/103 AND GMAP 15/2	SDU Sync to Audio Out Latency - AC11i: 48_3_gr, 32_1_gs	GMAP/UGG/MXLT/BV-198-C
GMAP 20/103 AND (NOT GMAP 15/1 OR NOT GMAP 15/2)	UGG Combined Latencies - AC11i: 48_3_gr, 32_1_gs	GMAP/UGG/MXLT/BV-292-C
GMAP 20/104	Low Latency Streaming - AC11i: 48_4_gr, 32_2_gs	GMAP/UGG/LLU/BV-44-C
GMAP 20/104 AND GMAP 15/1	Audio In to SDU Sync Latency - AC11i: 48_4_gr, 32_2_gs	GMAP/UGG/MXLT/BV-179-C
GMAP 20/104 AND GMAP 15/2	SDU Sync to Audio Out Latency - AC11i: 48_4_gr, 32_2_gs	GMAP/UGG/MXLT/BV-199-C
GMAP 20/104 AND (NOT GMAP 15/1 OR NOT GMAP 15/2)	UGG Combined Latencies - AC11i: 48_4_gr, 32_2_gs	GMAP/UGG/MXLT/BV-293-C
GMAP 20/105	Low Latency Streaming - AC11ii: 32_1_gr, 16_1_gs	GMAP/UGG/LLU/BV-113-C
GMAP 20/105 AND GMAP 15/1	Audio In to SDU Sync Latency - AC11ii: 32_1_gr, 16_1_gs	GMAP/UGG/MXLT/BV-180-C

Item	Feature	Test Case(s)
GMAP 20/105 AND GMAP 15/2	SDU Sync to Audio Out Latency - AC11ii: 32_1_gr, 16_1_gs	GMAP/UGG/MXLT/BV-200-C
GMAP 20/105 AND (NOT GMAP 15/1 OR NOT GMAP 15/2)	UGG Combined Latencies - AC11ii: 32_1_gr, 16_1_gs	GMAP/UGG/MXLT/BV-294-C
GMAP 20/106	Low Latency Streaming - AC11ii: 32_2_gr, 16_2_gs	GMAP/UGG/LLU/BV-114-C
GMAP 20/106 AND GMAP 15/1	Audio In to SDU Sync Latency - AC11ii: 32_2_gr, 16_2_gs	GMAP/UGG/MXLT/BV-181-C
GMAP 20/106 AND GMAP 15/2	SDU Sync to Audio Out Latency - AC11ii: 32_2_gr, 16_2_gs	GMAP/UGG/MXLT/BV-201-C
GMAP 20/106 AND (NOT GMAP 15/1 OR NOT GMAP 15/2)	UGG Combined Latencies - AC11ii: 32_2_gr, 16_2_gs	GMAP/UGG/MXLT/BV-295-C
GMAP 20/107	Low Latency Streaming - AC11ii: 48_1_gr, 16_1_gs	GMAP/UGG/LLU/BV-115-C
GMAP 20/107 AND GMAP 15/1	Audio In to SDU Sync Latency - AC11ii: 48_1_gr, 16_1_gs	GMAP/UGG/MXLT/BV-182-C
GMAP 20/107 AND GMAP 15/2	SDU Sync to Audio Out Latency - AC11ii: 48_1_gr, 16_1_gs	GMAP/UGG/MXLT/BV-202-C
GMAP 20/107 AND (NOT GMAP 15/1 OR NOT GMAP 15/2)	UGG Combined Latencies - AC11ii: 48_1_gr, 16_1_gs	GMAP/UGG/MXLT/BV-296-C
GMAP 20/108	Low Latency Streaming - AC11ii: 48_2_gr, 16_2_gs	GMAP/UGG/LLU/BV-116-C
GMAP 20/108 AND GMAP 15/1	Audio In to SDU Sync Latency - AC11ii: 48_2_gr, 16_2_gs	GMAP/UGG/MXLT/BV-183-C
GMAP 20/108 AND GMAP 15/2	SDU Sync to Audio Out Latency - AC11ii: 48_2_gr, 16_2_gs	GMAP/UGG/MXLT/BV-203-C
GMAP 20/108 AND (NOT GMAP 15/1 OR NOT GMAP 15/2)	UGG Combined Latencies - AC11ii: 48_2_gr, 16_2_gs	GMAP/UGG/MXLT/BV-297-C
GMAP 20/109	Low Latency Streaming - AC11ii: 32_1_gr, 32_1_gs	GMAP/UGG/LLU/BV-85-C
GMAP 20/109 AND GMAP 15/1	Audio In to SDU Sync Latency - AC11ii: 32_1_gr, 32_1_gs	GMAP/UGG/MXLT/BV-184-C
GMAP 20/109 AND GMAP 15/2	SDU Sync to Audio Out Latency - AC11ii: 32_1_gr, 32_1_gs	GMAP/UGG/MXLT/BV-204-C
GMAP 20/109 AND (NOT GMAP 15/1 OR NOT GMAP 15/2)	UGG Combined Latencies - AC11ii: 32_1_gr, 32_1_gs	GMAP/UGG/MXLT/BV-298-C
GMAP 20/110	Low Latency Streaming - AC11ii: 32_2_gr, 32_2_gs	GMAP/UGG/LLU/BV-86-C
GMAP 20/110 AND GMAP 15/1	Audio In to SDU Sync Latency - AC11ii: 32_2_gr, 32_2_gs	GMAP/UGG/MXLT/BV-185-C
GMAP 20/110 AND GMAP 15/2	SDU Sync to Audio Out Latency - AC11ii: 32_2_gr, 32_2_gs	GMAP/UGG/MXLT/BV-205-C

Item	Feature	Test Case(s)
GMAP 20/110 AND (NOT GMAP 15/1 OR NOT GMAP 15/2)	UGG Combined Latencies - AC11ii: 32_2_gr, 32_2_gs	GMAP/UGG/MXLT/BV-299-C
GMAP 20/111	Low Latency Streaming - AC11ii: 48_1_gr, 32_1_gs	GMAP/UGG/LLU/BV-45-C
GMAP 20/111 AND GMAP 15/1	Audio In to SDU Sync Latency - AC11ii: 48_1_gr, 32_1_gs	GMAP/UGG/MXLT/BV-186-C
GMAP 20/111 AND GMAP 15/2	SDU Sync to Audio Out Latency - AC11ii: 48_1_gr, 32_1_gs	GMAP/UGG/MXLT/BV-206-C
GMAP 20/111 AND (NOT GMAP 15/1 OR NOT GMAP 15/2)	UGG Combined Latencies - AC11ii: 48_1_gr, 32_1_gs	GMAP/UGG/MXLT/BV-300-C
GMAP 20/112	Low Latency Streaming - AC11ii: 48_2_gr, 32_2_gs	GMAP/UGG/LLU/BV-46-C
GMAP 20/112 AND GMAP 15/1	Audio In to SDU Sync Latency - AC11ii: 48_2_gr, 32_2_gs	GMAP/UGG/MXLT/BV-187-C
GMAP 20/112 AND GMAP 15/2	SDU Sync to Audio Out Latency - AC11ii: 48_2_gr, 32_2_gs	GMAP/UGG/MXLT/BV-207-C
GMAP 20/112 AND (NOT GMAP 15/1 OR NOT GMAP 15/2)	UGG Combined Latencies - AC11ii: 48_2_gr, 32_2_gs	GMAP/UGG/MXLT/BV-301-C
GMAP 20/113	Low Latency Streaming - AC11ii: 48_3_gr, 32_1_gs	GMAP/UGG/LLU/BV-49-C
GMAP 20/113 AND GMAP 15/1	Audio In to SDU Sync Latency - AC11ii: 48_3_gr, 32_1_gs	GMAP/UGG/MXLT/BV-188-C
GMAP 20/113 AND GMAP 15/2	SDU Sync to Audio Out Latency - AC11ii: 48_3_gr, 32_1_gs	GMAP/UGG/MXLT/BV-208-C
GMAP 20/113 AND (NOT GMAP 15/1 OR NOT GMAP 15/2)	UGG Combined Latencies - AC11ii: 48_3_gr, 32_1_gs	GMAP/UGG/MXLT/BV-302-C
GMAP 20/114	Low Latency Streaming - AC11ii: 48_4_gr, 32_2_gs	GMAP/UGG/LLU/BV-50-C
GMAP 20/114 AND GMAP 15/1	Audio In to SDU Sync Latency - AC11ii: 48_4_gr, 32_2_gs	GMAP/UGG/MXLT/BV-189-C
GMAP 20/114 AND GMAP 15/2	SDU Sync to Audio Out Latency - AC11ii: 48_4_gr, 32_2_gs	GMAP/UGG/MXLT/BV-209-C
GMAP 20/114 AND (NOT GMAP 15/1 OR NOT GMAP 15/2)	UGG Combined Latencies - AC11ii: 48_4_gr, 32_2_gs	GMAP/UGG/MXLT/BV-303-C
GMAP 33/1	Discovery of UGT	GMAP/UGT/DDI/BV-01-C
GMAP 103/2	UGT Characteristic over LE	GMAP/UGT/GRC/BV-01-C
GMAP 103/2 AND GMAP 108/2	UGT Characteristic over BR/EDR	GMAP/UGT/GRC/BV-02-C
GMAP 105/1	UGT Features Characteristic over LE - UGT Source	GMAP/UGT/GRC/BV-03-C
GMAP 105/2	UGT Features Characteristic over LE – UGT 80 kbps Source	GMAP/UGT/GRC/BV-04-C

Item	Feature	Test Case(s)
GMAP 105/3	UGT Features Characteristic over LE - UGT Sink	GMAP/UGT/GRC/BV-05-C
GMAP 105/4	UGT Features Characteristic over LE - UGT 64 kbps Sink	GMAP/UGT/GRC/BV-09-C
GMAP 105/5	UGT Features Characteristic over LE - UGT Multiplex	GMAP/UGT/GRC/BV-10-C
GMAP 105/6	UGT Features Characteristic over LE - UGT Multisink	GMAP/UGT/GRC/BV-11-C
GMAP 105/7	UGT Features Characteristic over LE - UGT Multisource	GMAP/UGT/GRC/BV-12-C
GMAP 105/1 AND GMAP 108/2	UGT Features Characteristic over BR/EDR - UGT Source	GMAP/UGT/GRC/BV-06-C
GMAP 105/2 AND GMAP 108/2	UGT Features Characteristic over BR/EDR - UGT 80 kbps Source	GMAP/UGT/GRC/BV-07-C
GMAP 105/3 AND GMAP 108/2	UGT Features Characteristic over BR/EDR - UGT Sink	GMAP/UGT/GRC/BV-08-C
GMAP 105/4 AND GMAP 108/2	UGT Features Characteristic over BR/EDR – UGT 64 kbps Sink	GMAP/UGT/GRC/BV-13-C
GMAP 105/5 AND GMAP 108/2	UGT Features Characteristic over BR/EDR - UGT Multiplex	GMAP/UGT/GRC/BV-14-C
GMAP 105/6 AND GMAP 108/2	UGT Features Characteristic over BR/EDR - UGT Multisink	GMAP/UGT/GRC/BV-15-C
GMAP 105/7 AND GMAP 108/2	UGT Features Characteristic over BR/EDR - UGT Multisource	GMAP/UGT/GRC/BV-16-C
GMAP 40/1	Low Latency Streaming and SDU Sync to Audio Out Latency - AC1: 32_1_gr	GMAP/UGT/LLU/BV-49-C GMAP/UGT/MXLT/BV-03-C
GMAP 40/2	Low Latency Streaming and SDU Sync to Audio Out Latency - AC1: 32_2_gr	GMAP/UGT/LLU/BV-50-C GMAP/UGT/MXLT/BV-04-C
GMAP 40/3	Low Latency Streaming and SDU Sync to Audio Out Latency - AC1: 48_1_gr	GMAP/UGT/LLU/BV-37-C GMAP/UGT/MXLT/BV-36-C
GMAP 40/4	Low Latency Streaming and SDU Sync to Audio Out Latency - AC1: 48_2_gr	GMAP/UGT/LLU/BV-38-C GMAP/UGT/MXLT/BV-37-C
GMAP 40/5	Low Latency Streaming and SDU Sync to Audio Out Latency - AC1: 48_3_gr	GMAP/UGT/LLU/BV-39-C GMAP/UGT/MXLT/BV-38-C
GMAP 40/6	Low Latency Streaming and SDU Sync to Audio Out Latency - AC1: 48_4_gr	GMAP/UGT/LLU/BV-40-C GMAP/UGT/MXLT/BV-39-C
GMAP 40/7	Low Latency Streaming and Audio In to SDU Sync Latency - AC2: 16_1_gs	GMAP/UGT/LLU/BV-65-C GMAP/UGT/MXLT/BV-122-C
GMAP 40/8	Low Latency Streaming and Audio In to SDU Sync Latency - AC2: 16_2_gs	GMAP/UGT/LLU/BV-66-C GMAP/UGT/MXLT/BV-123-C
GMAP 40/9	Low Latency Streaming and Audio In to SDU Sync Latency - AC2: 32_1_gs	GMAP/UGT/LLU/BV-45-C GMAP/UGT/MXLT/BV-80-C
GMAP 40/10	Low Latency Streaming and Audio In to SDU Sync Latency - AC2: 32_2_gs	GMAP/UGT/LLU/BV-46-C GMAP/UGT/MXLT/BV-81-C
GMAP 40/11	Low Latency Streaming and Audio In to SDU Sync Latency - AC2: 48_1_gs	GMAP/UGT/LLU/BV-47-C GMAP/UGT/MXLT/BV-82-C

Item	Feature	Test Case(s)
GMAP 40/12	Low Latency Streaming and Audio In to SDU Sync Latency - AC2: 48_2_gs	GMAP/UGT/LLU/BV-48-C GMAP/UGT/MXLT/BV-83-C
GMAP 40/27	Low Latency Streaming and SDU Sync to Audio Out Latency - AC4: 32_1_gr	GMAP/UGT/LLU/BV-55-C GMAP/UGT/MXLT/BV-09-C
GMAP 40/28	Low Latency Streaming and SDU Sync to Audio Out Latency - AC4: 32_2_gr	GMAP/UGT/LLU/BV-56-C GMAP/UGT/MXLT/BV-10-C
GMAP 40/29	Low Latency Streaming and SDU Sync to Audio Out Latency - AC4: 48_1_gr	GMAP/UGT/LLU/BV-41-C GMAP/UGT/MXLT/BV-48-C
GMAP 40/30	Low Latency Streaming and SDU Sync to Audio Out Latency - AC4: 48_2_gr	GMAP/UGT/LLU/BV-42-C GMAP/UGT/MXLT/BV-49-C
GMAP 40/31	Low Latency Streaming and SDU Sync to Audio Out Latency - AC4: 48_3_gr	GMAP/UGT/LLU/BV-43-C GMAP/UGT/MXLT/BV-50-C
GMAP 40/32	Low Latency Streaming and SDU Sync to Audio Out Latency - AC4: 48_4_gr	GMAP/UGT/LLU/BV-44-C GMAP/UGT/MXLT/BV-51-C
GMAP 40/45	Low Latency Streaming and SDU Sync to Audio Out Latency - AC6i: 32_1_gr	GMAP/UGT/LLU/BV-59-C GMAP/UGT/MXLT/BV-13-C
GMAP 40/46	Low Latency Streaming and SDU Sync to Audio Out Latency - AC6i: 32_2_gr	GMAP/UGT/LLU/BV-60-C GMAP/UGT/MXLT/BV-14-C
GMAP 40/47	Low Latency Streaming and SDU Sync to Audio Out Latency - AC6i: 48_1_gr	GMAP/UGT/LLU/BV-01-C GMAP/UGT/MXLT/BV-32-C
GMAP 40/48	Low Latency Streaming and SDU Sync to Audio Out Latency - AC6i: 48_2_gr	GMAP/UGT/LLU/BV-02-C GMAP/UGT/MXLT/BV-33-C
GMAP 40/49	Low Latency Streaming and SDU Sync to Audio Out Latency - AC6i: 48_3_gr	GMAP/UGT/LLU/BV-03-C GMAP/UGT/MXLT/BV-34-C
GMAP 40/50	Low Latency Streaming and SDU Sync to Audio Out Latency - AC6i: 48_4_gr	GMAP/UGT/LLU/BV-04-C GMAP/UGT/MXLT/BV-35-C
GMAP 40/13	Low Latency Streaming and Max Latency - AC3: 32_1_gr, 16_1_gs	GMAP/UGT/LLU/BV-67-C GMAP/UGT/MXLT/BV-110-C GMAP/UGT/MXLT/BV-124-C
GMAP 40/14	Low Latency Streaming and Max Latency - AC3: 32_2_gr, 16_2_gs	GMAP/UGT/LLU/BV-68-C GMAP/UGT/MXLT/BV-111-C GMAP/UGT/MXLT/BV-125-C
GMAP 40/15	Low Latency Streaming and Max Latency - AC3: 48_1_gr, 16_1_gs	GMAP/UGT/LLU/BV-69-C GMAP/UGT/MXLT/BV-112-C GMAP/UGT/MXLT/BV-126-C
GMAP 40/16	Low Latency Streaming and Max Latency - AC3: 48_2_gr, 16_2_gs	GMAP/UGT/LLU/BV-70-C GMAP/UGT/MXLT/BV-113-C GMAP/UGT/MXLT/BV-127-C
GMAP 40/17	Low Latency Streaming and Max Latency - AC3: 32_1_gr, 32_1_gs	GMAP/UGT/LLU/BV-51-C GMAP/UGT/MXLT/BV-05-C GMAP/UGT/MXLT/BV-84-C
GMAP 40/18	Low Latency Streaming and Max Latency - AC3: 32_2_gr, 32_2_gs	GMAP/UGT/LLU/BV-52-C GMAP/UGT/MXLT/BV-06-C GMAP/UGT/MXLT/BV-85-C

Item	Feature	Test Case(s)
GMAP 40/19	Low Latency Streaming and Max Latency - AC3: 48_1_gr, 32_1_gs	GMAP/UGT/LLU/BV-09-C GMAP/UGT/MXLT/BV-44-C GMAP/UGT/MXLT/BV-86-C
GMAP 40/20	Low Latency Streaming and Max Latency - AC3: 48_2_gr, 32_2_gs	GMAP/UGT/LLU/BV-10-C GMAP/UGT/MXLT/BV-45-C GMAP/UGT/MXLT/BV-87-C
GMAP 40/21	Low Latency Streaming and Max Latency - AC3: 48_1_gr, 48_1_gs	GMAP/UGT/LLU/BV-11-C GMAP/UGT/MXLT/BV-52-C GMAP/UGT/MXLT/BV-88-C
GMAP 40/22	Low Latency Streaming and Max Latency - AC3: 48_2_gr, 48_2_gs	GMAP/UGT/LLU/BV-12-C GMAP/UGT/MXLT/BV-53-C GMAP/UGT/MXLT/BV-89-C
GMAP 40/23	Low Latency Streaming and Max Latency - AC3: 48_3_gr, 32_1_gs	GMAP/UGT/LLU/BV-13-C GMAP/UGT/MXLT/BV-46-C GMAP/UGT/MXLT/BV-90-C
GMAP 40/24	Low Latency Streaming and Max Latency - AC3: 48_4_gr, 32_2_gs	GMAP/UGT/LLU/BV-14-C GMAP/UGT/MXLT/BV-47-C GMAP/UGT/MXLT/BV-91-C
GMAP 40/25	Low Latency Streaming and Max Latency - AC3: 48_3_gr, 48_1_gs	GMAP/UGT/LLU/BV-53-C GMAP/UGT/MXLT/BV-07-C GMAP/UGT/MXLT/BV-92-C
GMAP 40/26	Low Latency Streaming and Max Latency - AC3: 48_4_gr, 48_2_gs	GMAP/UGT/LLU/BV-54-C GMAP/UGT/MXLT/BV-08-C GMAP/UGT/MXLT/BV-93-C
GMAP 40/33	Low Latency Streaming and Max Latency - AC5: 32_1_gr, 16_1_gs	GMAP/UGT/LLU/BV-71-C GMAP/UGT/MXLT/BV-114-C GMAP/UGT/MXLT/BV-128-C
GMAP 40/34	Low Latency Streaming and Max Latency - AC5: 32_2_gr, 16_2_gs	GMAP/UGT/LLU/BV-72-C GMAP/UGT/MXLT/BV-115-C GMAP/UGT/MXLT/BV-129-C
GMAP 40/35	Low Latency Streaming and Max Latency - AC5: 48_1_gr, 16_1_gs	GMAP/UGT/LLU/BV-73-C GMAP/UGT/MXLT/BV-116-C GMAP/UGT/MXLT/BV-130-C
GMAP 40/36	Low Latency Streaming and Max Latency - AC5: 48_2_gr, 16_2_gs	GMAP/UGT/LLU/BV-74-C GMAP/UGT/MXLT/BV-117-C GMAP/UGT/MXLT/BV-131-C
GMAP 40/37	Low Latency Streaming and Max Latency - AC5: 32_1_gr, 32_1_gs	GMAP/UGT/LLU/BV-57-C GMAP/UGT/MXLT/BV-11-C GMAP/UGT/MXLT/BV-94-C
GMAP 40/38	Low Latency Streaming and Max Latency - AC5: 32_2_gr, 32_2_gs	GMAP/UGT/LLU/BV-58-C GMAP/UGT/MXLT/BV-12-C GMAP/UGT/MXLT/BV-95-C
GMAP 40/39	Low Latency Streaming and Max Latency - AC5: 48_1_gr, 32_1_gs	GMAP/UGT/LLU/BV-15-C GMAP/UGT/MXLT/BV-20-C GMAP/UGT/MXLT/BV-96-C

Item	Feature	Test Case(s)
GMAP 40/40	Low Latency Streaming and Max Latency - AC5: 48_2_gr, 32_2_gs	GMAP/UGT/LLU/BV-16-C GMAP/UGT/MXLT/BV-21-C GMAP/UGT/MXLT/BV-97-C
GMAP 40/41	Low Latency Streaming and Max Latency - AC5: 48_1_gr, 48_1_gs	GMAP/UGT/LLU/BV-17-C GMAP/UGT/MXLT/BV-54-C GMAP/UGT/MXLT/BV-98-C
GMAP 40/42	Low Latency Streaming and Max Latency - AC5: 48_2_gr, 48_2_gs	GMAP/UGT/LLU/BV-18-C GMAP/UGT/MXLT/BV-55-C GMAP/UGT/MXLT/BV-99-C
GMAP 40/43	Low Latency Streaming and Max Latency - AC5: 48_3_gr, 32_1_gs	GMAP/UGT/LLU/BV-19-C GMAP/UGT/MXLT/BV-22-C GMAP/UGT/MXLT/BV-100-C
GMAP 40/44	Low Latency Streaming and Max Latency - AC5: 48_4_gr, 32_2_gs	GMAP/UGT/LLU/BV-20-C GMAP/UGT/MXLT/BV-23-C GMAP/UGT/MXLT/BV-101-C
GMAP 40/51	Low Latency Streaming and Max Latency - AC8i: 32_1_gr, 16_1_gs	GMAP/UGT/LLU/BV-75-C GMAP/UGT/MXLT/BV-118-C GMAP/UGT/MXLT/BV-132-C
GMAP 40/52	Low Latency Streaming and Max Latency - AC8i: 32_2_gr, 16_2_gs	GMAP/UGT/LLU/BV-76-C GMAP/UGT/MXLT/BV-119-C GMAP/UGT/MXLT/BV-133-C
GMAP 40/53	Low Latency Streaming and Max Latency - AC8i: 48_1_gr, 16_1_gs	GMAP/UGT/LLU/BV-77-C GMAP/UGT/MXLT/BV-120-C GMAP/UGT/MXLT/BV-134-C
GMAP 40/54	Low Latency Streaming and Max Latency - AC8i: 48_2_gr, 16_2_gs	GMAP/UGT/LLU/BV-78-C GMAP/UGT/MXLT/BV-121-C GMAP/UGT/MXLT/BV-135-C
GMAP 40/55	Low Latency Streaming and Max Latency - AC8i: 32_1_gr, 32_1_gs	GMAP/UGT/LLU/BV-61-C GMAP/UGT/MXLT/BV-15-C GMAP/UGT/MXLT/BV-102-C
GMAP 40/56	Low Latency Streaming and Max Latency - AC8i: 32_2_gr, 32_2_gs	GMAP/UGT/LLU/BV-62-C GMAP/UGT/MXLT/BV-16-C GMAP/UGT/MXLT/BV-103-C
GMAP 40/57	Low Latency Streaming and Max Latency - AC8i: 48_1_gr, 32_1_gs	GMAP/UGT/LLU/BV-25-C GMAP/UGT/MXLT/BV-24-C GMAP/UGT/MXLT/BV-104-C
GMAP 40/58	Low Latency Streaming and Max Latency - AC8i: 48_2_gr, 32_2_gs	GMAP/UGT/LLU/BV-26-C GMAP/UGT/MXLT/BV-25-C GMAP/UGT/MXLT/BV-105-C
GMAP 40/59	Low Latency Streaming and Max Latency - AC8i: 48_1_gr, 48_1_gs	GMAP/UGT/LLU/BV-27-C GMAP/UGT/MXLT/BV-01-C GMAP/UGT/MXLT/BV-106-C
GMAP 40/60	Low Latency Streaming and Max Latency - AC8i: 48_2_gr, 48_2_gs	GMAP/UGT/LLU/BV-28-C GMAP/UGT/MXLT/BV-02-C GMAP/UGT/MXLT/BV-107-C

Item	Feature	Test Case(s)
GMAP 40/61	Low Latency Streaming and Max Latency - AC8i: 48_3_gr, 32_1_gs	GMAP/UGT/LLU/BV-29-C GMAP/UGT/MXLT/BV-26-C GMAP/UGT/MXLT/BV-108-C
GMAP 40/62	Low Latency Streaming and Max Latency - AC8i: 48_4_gr, 32_2_gs	GMAP/UGT/LLU/BV-30-C GMAP/UGT/MXLT/BV-27-C GMAP/UGT/MXLT/BV-109-C
GMAP 40/63	Low Latency Streaming and Max Latency - AC11i: 32_1_gr, 16_1_gs	GMAP/UGT/LLU/BV-79-C GMAP/UGT/MXLT/BV-136-C GMAP/UGT/MXLT/BV-146-C
GMAP 40/64	Low Latency Streaming and Max Latency - AC11i: 32_2_gr, 16_2_gs	GMAP/UGT/LLU/BV-80-C GMAP/UGT/MXLT/BV-137-C GMAP/UGT/MXLT/BV-147-C
GMAP 40/65	Low Latency Streaming and Max Latency - AC11i: 48_1_gr, 16_1_gs	GMAP/UGT/LLU/BV-81-C GMAP/UGT/MXLT/BV-138-C GMAP/UGT/MXLT/BV-148-C
GMAP 40/66	Low Latency Streaming and Max Latency - AC11i: 48_2_gr, 16_2_gs	GMAP/UGT/LLU/BV-82-C GMAP/UGT/MXLT/BV-139-C GMAP/UGT/MXLT/BV-149-C
GMAP 40/67	Low Latency Streaming and Max Latency - AC11i: 32_1_gr, 32_1_gs	GMAP/UGT/LLU/BV-63-C GMAP/UGT/MXLT/BV-140-C GMAP/UGT/MXLT/BV-150-C
GMAP 40/68	Low Latency Streaming and Max Latency - AC11i: 32_2_gr, 32_2_gs	GMAP/UGT/LLU/BV-64-C GMAP/UGT/MXLT/BV-141-C GMAP/UGT/MXLT/BV-151-C
GMAP 40/69	Low Latency Streaming and Max Latency - AC11i: 48_1_gr, 32_1_gs	GMAP/UGT/LLU/BV-31-C GMAP/UGT/MXLT/BV-142-C GMAP/UGT/MXLT/BV-152-C
GMAP 40/70	Low Latency Streaming and Max Latency - AC11i: 48_2_gr, 32_2_gs	GMAP/UGT/LLU/BV-32-C GMAP/UGT/MXLT/BV-143-C GMAP/UGT/MXLT/BV-153-C
GMAP 40/71	Low Latency Streaming and Max Latency - AC11i: 48_3_gr, 32_1_gs	GMAP/UGT/LLU/BV-35-C GMAP/UGT/MXLT/BV-144-C GMAP/UGT/MXLT/BV-154-C
GMAP 40/72	Low Latency Streaming and Max Latency - AC11i: 48_4_gr, 32_2_gs	GMAP/UGT/LLU/BV-36-C GMAP/UGT/MXLT/BV-145-C GMAP/UGT/MXLT/BV-155-C
GMAP 34/2 AND GMAP 35/9	Two UGTs Sync - AC6ii: 48_1_gr	GMAP/UGT/SYNC/BV-16-C
GMAP 34/2 AND GMAP 35/10	Two UGTs Sync - AC6ii: 48_2_gr	GMAP/UGT/SYNC/BV-17-C
GMAP 34/2 AND GMAP 35/11	Two UGTs Sync - AC6ii: 48_3_gr	GMAP/UGT/SYNC/BV-07-C
GMAP 34/2 AND GMAP 35/12	Two UGTs Sync - AC6ii: 48_4_gr	GMAP/UGT/SYNC/BV-08-C

Item	Feature	Test Case(s)
GMAP 34/3 AND GMAP 35/9 AND GMAP 35/3	Two UGTs Sync - AC8ii: 48_1_gr, 32_1_gs	GMAP/UGT/SYNC/BV-01-C
GMAP 34/3 AND GMAP 35/10 AND GMAP 35/4	Two UGTs Sync - AC8ii: 48_2_gr, 32_2_gs	GMAP/UGT/SYNC/BV-02-C
GMAP 34/3 AND GMAP 35/9 AND GMAP 35/5	Two UGTs Sync - AC8ii: 48_1_gr, 48_1_gs	GMAP/UGT/SYNC/BV-20-C
GMAP 34/3 AND GMAP 35/10 AND GMAP 35/6	Two UGTs Sync - AC8ii: 48_2_gr, 48_2_gs	GMAP/UGT/SYNC/BV-21-C
GMAP 34/3 AND GMAP 35/11 AND GMAP 35/3	Two UGTs Sync - AC8ii: 48_3_gr, 32_1_gs	GMAP/UGT/SYNC/BV-22-C
GMAP 34/3 AND GMAP 35/12 AND GMAP 35/4	Two UGTs Sync - AC8ii: 48_3_gr, 32_2_gs	GMAP/UGT/SYNC/BV-23-C
GMAP 34/4 AND GMAP 35/9 AND GMAP 35/3	Two UGTs Sync - AC11ii: 48_1_gr, 32_1_gs	GMAP/UGT/SYNC/BV-03-C
GMAP 34/4 AND GMAP 35/10 AND GMAP 35/4	Two UGTs Sync - AC11ii: 48_2_gr, 32_2_gs	GMAP/UGT/SYNC/BV-04-C
GMAP 34/4 AND GMAP 35/11 AND GMAP 35/3	Two UGTs Sync - AC11ii: 48_3_gr, 32_1_gs	GMAP/UGT/SYNC/BV-24-C
GMAP 34/4 AND GMAP 35/12 AND GMAP 35/4	Two UGTs Sync - AC11ii: 48_4_gr, 32_2_gs	GMAP/UGT/SYNC/BV-25-C
GMAP 34/5 AND GMAP 40/39	UGT Audio Outs Sync - AC5: 48_1_gr, 32_1_gs	GMAP/UGT/SYNC/BV-10-C
GMAP 34/5 AND GMAP 40/40	UGT Audio Outs Sync - AC5: 48_2_gr, 32_2_gs	GMAP/UGT/SYNC/BV-11-C
GMAP 34/5 AND GMAP 40/41	UGT Audio Outs Sync - AC5: 48_1_gr, 48_1_gs	GMAP/UGT/SYNC/BV-05-C
GMAP 34/5 AND GMAP 40/42	UGT Audio Outs Sync - AC5: 48_2_gr, 48_2_gs	GMAP/UGT/SYNC/BV-06-C
GMAP 34/5 AND GMAP 40/43	UGT Audio Outs Sync - AC5: 48_3_gr, 32_1_gs	GMAP/UGT/SYNC/BV-26-C
GMAP 34/5 AND GMAP 40/44	UGT Audio Outs Sync - AC5: 48_4_gr, 32_2_gs	GMAP/UGT/SYNC/BV-27-C
GMAP 34/5 AND GMAP 40/47	UGT Audio Outs Sync - AC6i: 48_1_gr	GMAP/UGT/SYNC/BV-18-C
GMAP 34/5 AND GMAP 40/48	UGT Audio Outs Sync - AC6i: 48_2_gr	GMAP/UGT/SYNC/BV-19-C
GMAP 34/5 AND GMAP 40/49	UGT Audio Outs Sync - AC6i: 48_3_gr	GMAP/UGT/SYNC/BV-28-C

Item	Feature	Test Case(s)
GMAP 34/5 AND GMAP 40/50	UGT Audio Outs Sync - AC6i: 48_4_gr	GMAP/UGT/SYNC/BV-29-C
GMAP 34/5 AND GMAP 40/57	UGT Audio Outs Sync - AC8i: 48_1_gr, 32_1_gs	GMAP/UGT/SYNC/BV-12-C
GMAP 34/5 AND GMAP 40/58	UGT Audio Outs Sync - AC8i: 48_2_gr, 32_2_gs	GMAP/UGT/SYNC/BV-13-C
GMAP 34/5 AND GMAP 40/59	UGT Audio Outs Sync - AC8i: 48_1_gr, 48_1_gs	GMAP/UGT/SYNC/BV-30-C
GMAP 34/5 AND GMAP 40/60	UGT Audio Outs Sync - AC8i: 48_2_gr, 48_2_gs	GMAP/UGT/SYNC/BV-31-C
GMAP 34/5 AND GMAP 40/61	UGT Audio Outs Sync - AC8i: 48_3_gr, 32_1_gs	GMAP/UGT/SYNC/BV-32-C
GMAP 34/5 AND GMAP 40/62	UGT Audio Outs Sync - AC8i: 48_4_gr, 32_2_gs	GMAP/UGT/SYNC/BV-33-C
GMAP 34/5 AND GMAP 40/69	UGT Audio Outs Sync - AC11i: 48_1_gr, 32_1_gs	GMAP/UGT/SYNC/BV-14-C
GMAP 34/5 AND GMAP 40/70	UGT Audio Outs Sync - AC11i: 48_2_gr, 32_2_gs	GMAP/UGT/SYNC/BV-15-C
GMAP 34/5 AND GMAP 40/71	UGT Audio Outs Sync - AC11i: 48_3_gr, 32_1_gs	GMAP/UGT/SYNC/BV-34-C
GMAP 34/5 AND GMAP 40/72	UGT Audio Outs Sync - AC11i: 48_4_gr, 32_2_gs	GMAP/UGT/SYNC/BV-35-C
GMAP 60/2	BGS metadata updates	GMAP/BGS/META/BV-01-C
GMAP 53/1	Discovery of BGS	GMAP/BGS/DDI/BV-01-C
GMAP 103/3	BGS Characteristic over LE	GMAP/BGS/GRC/BV-01-C
GMAP 103/3 AND GMAP 108/2	BGS Characteristic over BR/EDR	GMAP/BGS/GRC/BV-02-C
GMAP 106/1	BGS Features Characteristic over LE - BGS 96 kbps	GMAP/BGS/GRC/BV-03-C
GMAP 106/1 AND GMAP 108/2	BGS Features Characteristic over BR/EDR - BGS 96 kbps	GMAP/BGS/GRC/BV-04-C
GMAP 59/1	Low Latency Streaming - AC12: 48_1_g	GMAP/BGS/LLB/BV-05-C
GMAP 59/1 AND GMAP 55/1	Audio In to SDU Sync Latency - AC12: 48_1_g	GMAP/BGS/MXLT/BV-05-C
GMAP 59/2	Low Latency Streaming - AC12: 48_2_g	GMAP/BGS/LLB/BV-06-C
GMAP 59/2 AND GMAP 55/1	Audio In to SDU Sync Latency - AC12: 48_2_g	GMAP/BGS/MXLT/BV-06-C
GMAP 59/3	Low Latency Streaming - AC12: 48_3_g	GMAP/BGS/LLB/BV-07-C
GMAP 59/3 AND GMAP 55/1	Audio In to SDU Sync Latency - AC12: 48_3_g	GMAP/BGS/MXLT/BV-07-C
GMAP 59/4	Low Latency Streaming - AC12: 48_4_g	GMAP/BGS/LLB/BV-08-C
GMAP 59/4 AND GMAP 55/1	Audio In to SDU Sync Latency - AC12: 48_4_g	GMAP/BGS/MXLT/BV-08-C
GMAP 59/5	Low Latency Streaming - AC13: 48_1_g	GMAP/BGS/LLB/BV-01-C
GMAP 59/5 AND GMAP 55/1	Audio In to SDU Sync Latency - AC13: 48_1_g	GMAP/BGS/MXLT/BV-01-C

Item	Feature	Test Case(s)
GMAP 59/6	Low Latency Streaming - AC13: 48_2_g	GMAP/BGS/LLB/BV-02-C
GMAP 59/6 AND GMAP 55/1	Audio In to SDU Sync Latency - AC13: 48_2_g	GMAP/BGS/MXLT/BV-02-C
GMAP 59/7	Low Latency Streaming - AC13: 48_3_g	GMAP/BGS/LLB/BV-03-C
GMAP 59/7 AND GMAP 55/1	Audio In to SDU Sync Latency - AC13: 48_3_g	GMAP/BGS/MXLT/BV-03-C
GMAP 59/8	Low Latency Streaming - AC13: 48_4_g	GMAP/BGS/LLB/BV-04-C
GMAP 59/8 AND GMAP 55/1	Audio In to SDU Sync Latency - AC13: 48_4_g	GMAP/BGS/MXLT/BV-04-C
GMAP 59/9	Low Latency Streaming - AC14: 48_1_g	GMAP/BGS/LLB/BV-09-C
GMAP 59/9 AND GMAP 55/1	Audio In to SDU Sync Latency - AC14: 48_1_g	GMAP/BGS/MXLT/BV-09-C
GMAP 59/10	Low Latency Streaming - AC14: 48_2_g	GMAP/BGS/LLB/BV-10-C
GMAP 59/10 AND GMAP 55/1	Audio In to SDU Sync Latency - AC14: 48_2_g	GMAP/BGS/MXLT/BV-10-C
GMAP 59/11	Low Latency Streaming - AC14: 48_3_g	GMAP/BGS/LLB/BV-11-C
GMAP 59/11 AND GMAP 55/1	Audio In to SDU Sync Latency - AC14: 48_3_g	GMAP/BGS/MXLT/BV-11-C
GMAP 59/12	Low Latency Streaming - AC14: 48_4_g	GMAP/BGS/LLB/BV-12-C
GMAP 59/12 AND GMAP 55/1	Audio In to SDU Sync Latency - AC14: 48_4_g	GMAP/BGS/MXLT/BV-12-C
GMAP 111/1	BGR Includes Game Context Type	GMAP/BGR/SAC/BV-01-C
GMAP 73/1	Discovery of BGR	GMAP/BGR/DDI/BV-01-C
GMAP 103/4	BGR Characteristic over LE	GMAP/BGR/GRC/BV-01-C
GMAP 103/4 AND GMAP 108/2	BGR Characteristic over BR/EDR	GMAP/BGR/GRC/BV-02-C
GMAP 107/1	BGR Features Characteristic over LE - BGR Multisink	GMAP/BGR/GRC/BV-03-C
GMAP 107/2	BGR Features Characteristic over LE - BGR Multiplex	GMAP/BGR/GRC/BV-04-C
GMAP 107/1 AND GMAP 108/2	BGR Features Characteristic over BR/EDR - BGR Multisink	GMAP/BGR/GRC/BV-05-C
GMAP 107/2 AND GMAP 108/2	BGR Features Characteristic over BR/EDR - BGR Multiplex	GMAP/BGR/GRC/BV-06-C
GMAP 79/1	Low Latency Streaming and SDU Sync to Audio Out Latency - AC12: 48_1_g	GMAP/BGR/LLB/BV-13-C GMAP/BGR/MXLT/BV-05-C
GMAP 79/2	Low Latency Streaming and SDU Sync to Audio Out Latency - AC12: 48_2_g	GMAP/BGR/LLB/BV-14-C GMAP/BGR/MXLT/BV-06-C
GMAP 79/3	Low Latency Streaming and SDU Sync to Audio Out Latency - AC12: 48_3_g	GMAP/BGR/LLB/BV-15-C GMAP/BGR/MXLT/BV-07-C
GMAP 79/4	Low Latency Streaming and SDU Sync to Audio Out Latency - AC12: 48_4_g	GMAP/BGR/LLB/BV-16-C GMAP/BGR/MXLT/BV-08-C
GMAP 79/9	Low Latency Streaming - AC13: 48_1_g, 2 BGR	GMAP/BGR/LLB/BV-01-C

Item	Feature	Test Case(s)
GMAP 79/10	Low Latency Streaming - AC13: 48_2_g, 2 BGR	GMAP/BGR/LLB/BV-02-C
GMAP 79/11	Low Latency Streaming - AC13: 48_3_g, 2 BGR	GMAP/BGR/LLB/BV-03-C
GMAP 79/12	Low Latency Streaming - AC13: 48_4_g, 2 BGR	GMAP/BGR/LLB/BV-04-C
GMAP 79/5	Low Latency Streaming - AC13: 48_1_g, right and left	GMAP/BGR/LLB/BV-09-C
GMAP 79/6	Low Latency Streaming - AC13: 48_2_g, right and left	GMAP/BGR/LLB/BV-10-C
GMAP 79/7	Low Latency Streaming - AC13: 48_3_g, right and left	GMAP/BGR/LLB/BV-11-C
GMAP 79/8	Low Latency Streaming - AC13: 48_4_g, right and left	GMAP/BGR/LLB/BV-12-C
GMAP 79/13	Low Latency Streaming and SDU Sync to Audio Out Latency - AC14: 48_1_g	GMAP/BGR/LLB/BV-17-C GMAP/BGR/MXLT/BV-09-C
GMAP 79/14	Low Latency Streaming and SDU Sync to Audio Out Latency - AC14: 48_2_g	GMAP/BGR/LLB/BV-18-C GMAP/BGR/MXLT/BV-10-C
GMAP 79/15	Low Latency Streaming and SDU Sync to Audio Out Latency - AC14: 48_3_g	GMAP/BGR/LLB/BV-19-C GMAP/BGR/MXLT/BV-11-C
GMAP 79/16	Low Latency Streaming and SDU Sync to Audio Out Latency - AC14: 48_4_g	GMAP/BGR/LLB/BV-20-C GMAP/BGR/MXLT/BV-12-C
GMAP 79/5 OR GMAP 79/9	SDU Sync to Audio Out Latency - AC13: 48_1_g	GMAP/BGR/MXLT/BV-01-C
GMAP 79/6 OR GMAP 79/10	SDU Sync to Audio Out Latency - AC13: 48_2_g	GMAP/BGR/MXLT/BV-02-C
GMAP 79/7 OR GMAP 79/11	SDU Sync to Audio Out Latency - AC13: 48_3_g	GMAP/BGR/MXLT/BV-03-C
GMAP 79/8 OR GMAP 79/12	SDU Sync to Audio Out Latency - AC13: 48_4_g	GMAP/BGR/MXLT/BV-04-C
GMAP 75/1 AND GMAP 79/9	Two BGRs Sync - AC13: 48_1_g	GMAP/BGR/SYNC/BV-03-C
GMAP 75/1 AND GMAP 79/10	Two BGRs Sync - AC13: 48_2_g	GMAP/BGR/SYNC/BV-04-C
GMAP 75/1 AND GMAP 79/11	Two BGRs Sync - AC13: 48_3_g	GMAP/BGR/SYNC/BV-01-C
GMAP 75/1 AND GMAP 79/12	Two BGRs Sync - AC13: 48_4_g	GMAP/BGR/SYNC/BV-02-C
GMAP 75/2 AND GMAP 79/5	BGR Audio Outs Sync - AC13: 48_1_g	GMAP/BGR/SYNC/BV-07-C
GMAP 75/2 AND GMAP 79/6	BGR Audio Outs Sync - AC13: 48_2_g	GMAP/BGR/SYNC/BV-08-C
GMAP 75/2 AND GMAP 79/7	BGR Audio Outs Sync - AC13: 48_3_g	GMAP/BGR/SYNC/BV-05-C
GMAP 75/2 AND GMAP 79/8	BGR Audio Outs Sync - AC13: 48_4_g	GMAP/BGR/SYNC/BV-06-C

Item	Feature	Test Case(s)
GMAP 75/2 AND GMAP 79/13	BGR Audio Outs Sync - AC14: 48_1_g	GMAP/BGR/SYNC/BV-09-C
GMAP 75/2 AND GMAP 79/14	BGR Audio Outs Sync - AC14: 48_2_g	GMAP/BGR/SYNC/BV-10-C
GMAP 75/2 AND GMAP 79/15	BGR Audio Outs Sync - AC14: 48_3_g	GMAP/BGR/SYNC/BV-11-C
GMAP 75/2 AND GMAP 79/16	BGR Audio Outs Sync - AC14: 48_4_g	GMAP/BGR/SYNC/BV-12-C
GMAP 93/2 OR GMAP 93/3	GMAS Service Discovery	GMAP/CL/CGGIT/SER/BV-01-C
GMAP 92/1	GMAP Role Read Characteristic, Client	GMAP/CL/CGGIT/CHA/BV-01-C GMAP/CL/GMAS/BI-01-C
GMAP 92/2	UGG Features Characteristic	GMAP/CL/CGGIT/CHA/BV-03-C GMAP/CL/GMAS/BI-03-C
GMAP 92/3	UGT Features Characteristic	GMAP/CL/CGGIT/CHA/BV-02-C GMAP/CL/GMAS/BI-02-C
GMAP 92/4	BGS Features Characteristic	GMAP/CL/CGGIT/CHA/BV-04-C GMAP/CL/GMAS/BI-04-C
GMAP 92/5	BGR Features Characteristic	GMAP/CL/CGGIT/CHA/BV-05-C GMAP/CL/GMAS/BI-05-C
GMAP 1/6	Service GGIT - GMAS	GMAP/SR/SGGIT/SER/BV-01-C
GMAP 102/1	Characteristic GGIT - GMAP Role	GMAP/SR/SGGIT/CHA/BV-01-C
GMAP 102/2	Characteristic GGIT - UGG Features	GMAP/SR/SGGIT/CHA/BV-03-C
GMAP 102/3	Characteristic GGIT - UGT Features	GMAP/SR/SGGIT/CHA/BV-02-C
GMAP 102/4	Characteristic GGIT - BGS Features	GMAP/SR/SGGIT/CHA/BV-04-C
GMAP 102/5	Characteristic GGIT - BGR Features	GMAP/SR/SGGIT/CHA/BV-05-C
GMAP 109/1	SDP Record	GMAP/SR/SGGIT/SDP/BV-01-C
GMAP 78/1	BGR Audio Location Front Left	GMAP/BGR/AL/BV-01-C
GMAP 78/2	BGR Audio Location Front Right	GMAP/BGR/AL/BV-02-C
GMAP 78/3	BGR Audio Location Front Right and Front Left	GMAP/BGR/AL/BV-03-C

Table 5.1: Test case mapping

6 Revision history and acknowledgments

Revision History

Publication Number	Revision Number	Date	Comments
0	p0	2023-11-14	Approved by BTI on 2023-10-22. GMAP v1.0 adopted by the BoD on 2023-11-14. Prepared for initial publication.
	p1r00–r09	2024-11-07 – 2025-03-31	<p>TSE 23703 (rating 1): Added Appendix A to provide an example of Member-defined latency test approaches. Updated the Test Strategy section to include a pointer to this new appendix.</p> <p>TSE 24704 (rating 1): Removed content from the Test Strategy section because it was moved to the TSTO.</p> <p>TSE 25191 (rating 1): Added Instrumentation Delay to the list of additional definitions.</p> <p>TSE 25884 (rating 4): Per E25789, added new test cases GMAP/UGG/META/BV-01-C and -02-C. Updated the TCMT accordingly. Updated reference [12], test groups, and the TCID conventions table.</p> <p>TSE 25885 (rating 4): Per E25641, added an Updating Metadata section, including new TC GMAP/BGS/META/BV-01-C. Updated the references list, test groups, and TCID conventions table.</p> <p>TSE 27218 (rating 4): Per E25641, added one new TC: GMAP/BGR/SAC/BV-01-C. Updated the TCMT accordingly. Updated the test groups section and the TCID conventions table.</p> <p>TSE 27392 (rating 1): Updated the initial conditions for GMAP/BGS/LLB/BV-01-C – -12-C, GMAP/BGR/LLB/BV-01-C – -04-C and -09-C – -20-C.</p>
1	p1	2025-05-06	Approved by BTI on 2025-04-07. GMAP v1.0.1 adopted by the BoD on 2025-05-05. Prepared for TCRL 2025-1-addition publication.
	p2r00–r01	2025-07-23 – 2025-08-07	TSE 27639 (rating 2): Updated Initial Condition in Low Latency Audio Streaming – BGS. Updated Initial Condition, Test Procedure and Expected Outcome in Low Latency Audio Streaming – BGR.
2	p2	2025-11-04	Approved by BTI on 2025-09-29. Prepared for TCRL pkg101 publication.

Acknowledgments

Name	Company
Dejan Berec	Bluetooth SIG, Inc.
Tharon Hall	Bluetooth SIG, Inc.
Oren Haggai	Intel Corporation
Andrew Estrada	Sony Group Corporation
Masahiko Seki	Sony Group Corporation
Akio Tanaka	Sony Group Corporation
Jeff Solum	Starkey Labs



Appendix A Examples of Member-defined latency test approaches

A.1 Injecting an audio test pattern

Figure A.1 describes one approach for measuring latency. An audio test pattern is injected into the source audio using a multiplexer.

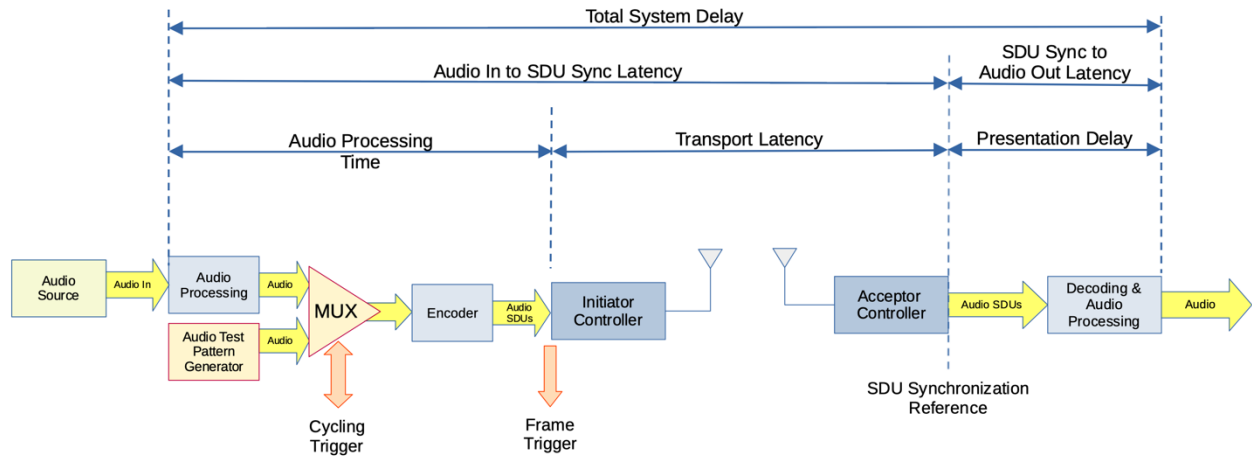

Figure A.1: Injection of Audio Test Pattern and Detection of Transport Latency Start

A cycling trigger switches the audio input from the conventional audio source to the audio test pattern generator. When test pattern SDUs arrive at the Initiator Controller, their arrival is detected externally. The audio output is monitored directly and the arrival of the audio test pattern at Audio Out is detected. The Transport Latency plus the Presentation Delay is measured directly. The SDU Synchronization Reference can be determined over-the-air, and thus Transport Latency and Presentation Delay can also be determined.