

# Cycling Power Profile (CPP)

## **Bluetooth® Test Suite**

---

- **Revision:** CPP.TS.p14
- **Revision Date:** 2025-11-04
- **Prepared By:** BTI
- **Published during TCRL:** TCRL.pkg101



This document, regardless of its title or content, is not a Bluetooth Specification as defined in the Bluetooth Patent/Copyright License Agreement (“PCLA”) and Bluetooth Trademark License Agreement. Use of this document by members of Bluetooth SIG is governed by the membership and other related agreements between Bluetooth SIG Inc. (“Bluetooth SIG”) and its members, including the PCLA and other agreements posted on Bluetooth SIG’s website located at [www.bluetooth.com](http://www.bluetooth.com).

THIS DOCUMENT IS PROVIDED “AS IS” AND BLUETOOTH SIG, ITS MEMBERS, AND THEIR AFFILIATES MAKE NO REPRESENTATIONS OR WARRANTIES AND DISCLAIM ALL WARRANTIES, EXPRESS OR IMPLIED, INCLUDING ANY WARRANTY OF MERCHANTABILITY, TITLE, NON-INFRINGEMENT, FITNESS FOR ANY PARTICULAR PURPOSE, THAT THE CONTENT OF THIS DOCUMENT IS FREE OF ERRORS.

TO THE EXTENT NOT PROHIBITED BY LAW, BLUETOOTH SIG, ITS MEMBERS, AND THEIR AFFILIATES DISCLAIM ALL LIABILITY ARISING OUT OF OR RELATING TO USE OF THIS DOCUMENT AND ANY INFORMATION CONTAINED IN THIS DOCUMENT, INCLUDING LOST REVENUE, PROFITS, DATA OR PROGRAMS, OR BUSINESS INTERRUPTION, OR FOR SPECIAL, INDIRECT, CONSEQUENTIAL, INCIDENTAL OR PUNITIVE DAMAGES, HOWEVER CAUSED AND REGARDLESS OF THE THEORY OF LIABILITY, AND EVEN IF BLUETOOTH SIG, ITS MEMBERS, OR THEIR AFFILIATES HAVE BEEN ADVISED OF THE POSSIBILITY OF SUCH DAMAGES.

This document is proprietary to Bluetooth SIG. This document may contain or cover subject matter that is intellectual property of Bluetooth SIG and its members. The furnishing of this document does not grant any license to any intellectual property of Bluetooth SIG or its members.

This document is subject to change without notice.

Copyright © 2013–2025 by Bluetooth SIG, Inc. The Bluetooth word mark and logos are owned by Bluetooth SIG, Inc. Other third-party brands and names are the property of their respective owners.



# Contents

<b>1</b>	<b>Scope</b> .....	<b>6</b>
<b>2</b>	<b>References, definitions, and abbreviations</b> .....	<b>7</b>
2.1	References .....	7
2.2	Definitions .....	7
2.3	Acronyms and abbreviations .....	7
<b>3</b>	<b>Test Suite Structure (TSS)</b> .....	<b>8</b>
3.1	Overview .....	8
3.2	Test Strategy .....	8
3.2.1	Test database requirements .....	9
3.3	Test groups .....	9
<b>4</b>	<b>Test cases (TC)</b> .....	<b>10</b>
4.1	Introduction .....	10
4.1.1	Test case identification conventions .....	10
4.1.2	Conformance .....	10
4.1.3	Pass/Fail verdict conventions .....	11
4.2	Setup preambles .....	11
4.2.1	ATT Bearer on LE Transport .....	11
4.2.2	ATT Bearer on BR/EDR Transport .....	11
4.2.3	Collector: Configure CP Sensor for use with Cycling Power Control Point .....	12
4.2.4	LE Collector: Scan to detect Sensor Connectable Advertisements and initiate a connection .....	12
4.2.5	LE CP Observer: Scan to detect Sensor Non-Connectable Advertisements .....	13
4.2.6	BR/EDR Collector .....	13
4.3	Generic GATT Integrated Tests .....	15
	CPP/COL/CGGIT/SER/BV-01-C [Service GGIT – Cycling Power Service] .....	15
	CPP/COL/CGGIT/CHA/BV-01-C [Characteristic GGIT – Cycling Power Feature] .....	15
	CPP/COL/CGGIT/CHA/BV-02-C [Characteristic GGIT – Cycling Power Measurement] .....	15
	CPP/COL/CGGIT/CHA/BV-03-C [Characteristic GGIT – Sensor Location] .....	15
	CPP/COL/CGGIT/CHA/BV-04-C [Characteristic GGIT – Cycling Power Control Point] .....	15
	CPP/COL/CGGIT/CHA/BV-05-C [Characteristic GGIT – Cycling Power Vector] .....	15
	CPP/COL/CGGIT/SER/BV-02-C [Service GGIT – Device Information Service] .....	15
	CPP/COL/CGGIT/SER/BV-03-C [Service GGIT – Battery Service] .....	15
	CPP/COL/CGGIT/CHA/BV-06-C [Characteristic GGIT – Battery Level] .....	15
	CPP/SEN/SGGIT/SDPNF/BV-01-C [Not discoverable over BR/EDR – Cycling Power Service] .....	15
4.3.1	Generic GATT Indication Supported Features characteristic .....	16
	CPP/COL/CGGIT/ISFC/BV-01-C [Characteristic GGIT – Cycling Power Feature indication] .....	16
4.4	Discover Services and Characteristics .....	17
	CPP/COL/CPD/BV-15-C [Discover Device Information Service Characteristics] .....	17
	CPP/COL/CPD/BV-16-C [Read Device Information Service Characteristics] .....	18
4.5	Cycling Power Features .....	19
	CPP/SEN/CPF/BV-01-C [Cycling Power Service UUID in AD] .....	19
	CPP/SEN/CPF/BV-02-C [Local Name included in AD or Scan Response] .....	19
	CPP/SEN/CPF/BV-03-C [Appearance included in AD or Scan Response] .....	20
	CPP/COL/CPF/BI-01-C [Read Cycling Power Feature characteristic with reserved value] .....	21
	CPP/COL/CPF/BV-05-C [Configure Cycling Power Measurement for Notification] .....	22
	CPP/COL/CPF/BV-06-C [Receive Cycling Power Measurement Notifications] .....	23
	CPP/COL/CPF/BV-07-C [Receive Cycling Power Measurement Notifications – Accumulated Torque Roll Over] .....	25



CPP/COL/CPF/BV-08-C [Receive Cycling Power Measurement Notifications – Last Wheel Event Time Roll Over] .....	26
CPP/COL/CPF/BV-09-C [Receive Cycling Power Measurement Notifications – Cumulative Crank Revolutions Roll Over] .....	27
CPP/COL/CPF/BV-10-C [Receive Cycling Power Measurement Notifications – Last Crank Event Time Roll Over] .....	28
CPP/COL/CPF/BV-11-C [Receive Cycling Power Measurement Notifications – Accumulated Energy Roll Over] .....	29
CPP/COL/CPF/BV-12-C [Receive Cycling Power Measurement Notifications – Wheel Revolution Data After Link Loss] .....	30
CPP/COL/CPF/BV-13-C [Receive Cycling Power Measurement Notifications – Crank Revolution Data After Link Loss] .....	31
CPP/COL/CPF/BV-14-C [Receive Cycling Power Measurement Notifications – Reverse Wheel Revolution] .....	32
CPP/COL/CPF/BV-15-C [Receive Cycling Power Measurement Notifications – Accumulated Torque Value Decreases] .....	33
CPP/COL/CPF/BI-02-C [Receive Cycling Power Measurement Notifications with reserved flags] .....	34
CPP/COL/CPF/BI-03-C [Receive Cycling Power Measurement Notifications with additional octets not represented in the flags field] .....	35
CPP/COL/CPF/BV-17-C [Receive Cycling Power Measurement Notifications from a Distributed Power System – Calculates Total Instantaneous Power] .....	37
CPP/COL/CPF/BV-18-C [Receive Cycling Power Measurement Notifications from a Distributed Power System – Calculates Pedal Power Balance] .....	38
CPP/COL/CPF/BI-04-C [Read Sensor Location characteristic with reserved value] .....	39
CPP/COL/CPF/BV-20-C [Configure Cycling Power Vector for Notification] .....	40
CPP/COL/CPF/BV-21-C [Receive Cycling Power Vector Notifications] .....	41
CPP/COL/CPF/BV-22-C [Receive Cycling Power Vector Notifications – Cumulative Crank Revolutions Roll Over] .....	42
CPP/COL/CPF/BV-23-C [Receive Cycling Power Vector Notifications – Last Crank Event Time Roll Over] .....	43
CPP/COL/CPF/BI-05-C [Receive Cycling Power Vector Notifications with reserved flags] .....	44
CPP/COL/CPF/BV-24-C [Lost Bond Procedure when using LE Transport] .....	45
CPP/COL/CPF/BV-25-C [Lost Bond Procedure when using BR/EDR transport] .....	46
CPP/COL/CPF/BV-26-C [Configure Cycling Power Measurement for Broadcast] .....	47
CPP/OBS/CPF/BV-27-C [Receive Cycling Power Measurement Broadcast] .....	48
CPP/OBS/CPF/BV-28-C [Receive Cycling Power Measurement Broadcast – Accumulated Torque Roll Over] .....	49
CPP/OBS/CPF/BV-29-C [Receive Cycling Power Measurement Broadcast – Last Wheel Event Time Roll Over] .....	50
CPP/OBS/CPF/BV-30-C [Receive Cycling Power Measurement Broadcast – Cumulative Crank Revolutions Roll Over] .....	51
CPP/OBS/CPF/BV-31-C [Receive Cycling Power Measurement Broadcast – Last Crank Event Time Roll Over] .....	52
CPP/OBS/CPF/BV-32-C [Receive Cycling Power Measurement Broadcast – Accumulated Energy Roll Over] .....	53
CPP/OBS/CPF/BI-06-C [Receive Cycling Power Measurement Broadcast with reserved flags] .....	54
CPP/OBS/CPF/BI-07-C [Receive Cycling Power Measurement Broadcast with additional octets not represented in the flags field] .....	55
CPP/OBS/CPF/BV-33-C [Receive Cycling Power Measurement Broadcast from a Distributed Power System] .....	55
CPP/OBS/CPF/BV-34-C [Receive Cycling Power Measurement Broadcast from a Distributed Power System – Calculates Total Instantaneous Power] .....	56
CPP/OBS/CPF/BV-35-C [Receive Cycling Power Measurement Broadcast from a Distributed Power System – Calculates Pedal Power Balance] .....	57
CPP/COL/CPF/BV-36-C [Receive Cycling Power Measurement Notifications from a Legacy CP Sensor] .....	58



CPP/COL/CPF/BV-37-C [Receive Cycling Power Measurement Notifications from a CP Sensor – Not For Use In A Distributed Power System].....	60
CPP/COL/CPF/BV-38-C [Receive Cycling Power Measurement Notifications from a CP Sensor – Can Be Used In A Distributed Power System].....	62
CPP/COL/CPF/BV-39-C [Receive Cycling Power Measurement Notifications from two CP Sensors – Can Be Used In A Distributed Power System – Total Instantaneous Power].....	64
CPP/COL/CPF/BV-40-C [Receive Cycling Power Measurement Notifications from two CP Sensors – Can Be Used in A Distributed Power System – Pedal Power Balance] .....	65
CPP/COL/CPF/BV-41-C [Receive Cycling Power Measurement Notifications from two Legacy CP Sensors].....	66
CPP/COL/CPF/BV-42-C [Read Cycling Power Feature Characteristic with Bonding Enabled] .....	68
CPP/COL/CPF/BV-43-C [Enable Cycling Power Feature Characteristic for Indication or Read Feature Characteristic Upon Reconnection].....	69
<b>4.6 Service Procedures – Set Cumulative Value.....</b>	<b>70</b>
CPP/COL/SPS/BV-01-C [Set Cumulative Value – Set to zero].....	70
CPP/COL/SPS/BV-02-C [Set Cumulative Value - Set to non-zero] .....	71
<b>4.7 Service Procedures – Handle CP Sensor Parameters.....</b>	<b>71</b>
<b>4.7.1 Cycling Power Control Point Procedures: Update and Set .....</b>	<b>72</b>
CPP/COL/SPP/BV-01-C [Update Sensor Location] .....	72
CPP/COL/SPP/BV-03-C [Set Crank Length].....	72
CPP/COL/SPP/BV-05-C [Set Chain Length].....	72
CPP/COL/SPP/BV-07-C [Set Chain Weight].....	72
CPP/COL/SPP/BV-09-C [Set Span Length].....	72
<b>4.7.2 Cycling Power Control Point Procedures: Request.....</b>	<b>73</b>
CPP/COL/SPP/BV-02-C [Request Supported Sensor Locations] .....	73
CPP/COL/SPP/BV-04-C [Request Crank Length].....	73
CPP/COL/SPP/BV-06-C [Request Chain Length].....	73
CPP/COL/SPP/BV-08-C [Request Chain Weight].....	73
CPP/COL/SPP/BV-10-C [Request Span Length].....	73
CPP/COL/SPP/BV-11-C [Request Factory Calibration Date].....	73
CPP/COL/SPP/BV-12-C [Request Sampling Rate].....	73
<b>4.8 Service Procedure – Offset Compensation .....</b>	<b>74</b>
CPP/COL/SPO/BV-01-C [Start Offset Compensation – Force Based CP Sensor] .....	74
CPP/COL/SPO/BV-02-C [Start Offset Compensation – Torque Based CP Sensor] .....	74
<b>4.9 Service Procedure – Mask Characteristic Content.....</b>	<b>75</b>
CPP/COL/SPM/BV-01-C [Mask Cycling Power Measurement Characteristic Content] .....	75
<b>4.10 Service Procedure – Enhanced Offset Compensation .....</b>	<b>75</b>
CPP/COL/SPO/BV-03-C [Start Enhanced Offset Compensation – Force Based CP Sensor] .....	75
CPP/COL/SPO/BV-04-C [Start Enhanced Offset Compensation – Torque Based CP Sensor] .....	76
CPP/COL/SPO/BI-01-C [Start Enhanced Offset Compensation – Incorrect Calibration Position].....	77
CPP/COL/SPO/BI-02-C [Start Enhanced Offset Compensation – Manufacturer Specific Error].....	78
<b>4.11 Service Procedures – General Error Handling .....</b>	<b>78</b>
<b>4.11.1 General Error Handling .....</b>	<b>78</b>
CPP/COL/SPE/BI-01-C [Unsupported Op Code].....	79
CPP/COL/SPE/BI-02-C [Invalid Parameter].....	79
CPP/COL/SPE/BI-03-C [Operation Failed] .....	79
CPP/COL/SPE/BI-04-C [Cycling Power Control Point Procedure Timeout].....	79
<b>5 Test case mapping .....</b>	<b>81</b>
<b>6 Revision history and acknowledgments .....</b>	<b>85</b>

# 1 Scope

---

This Bluetooth document contains the Test Suite Structure (TSS) and test cases to test the implementation of the Bluetooth Cycling Power Profile Specification with the objective to provide a high probability of air interface interoperability between the tested implementation and other manufacturers' Bluetooth devices.

## 2 References, definitions, and abbreviations

### 2.1 References

This document incorporates provisions from other publications by dated or undated reference. These references are cited at the appropriate places in the text, and the publications are listed hereinafter. Additional definitions and abbreviations can be found in [1], [2], and [3].

- [1] Test Strategy and Terminology Overview
- [2] Bluetooth Core Specification, Version 4.0 or later
- [3] Cycling Power Profile Specification, Version 1.0 or later
- [4] Cycling Power Profile ICS, CPP.ICS
- [5] GATT Test Suite, GATT.TS
- [6] Cycling Power Service Specification, Version 1.0 or later
- [7] Cycling Power Service Test Suite, CPS.TS
- [8] Device Information Service Specification, Version 1.1 or later
- [9] Battery Service Specification, Version 1.0 or later
- [10] Cycling Power Profile Implementation eXtra Information for Test, IXIT
- [11] Characteristic and Descriptor descriptions are accessible via the Bluetooth SIG Assigned Numbers
- [12] [Appropriate Language Mapping Tables](#) document
- [13] Cycling Power Profile Specification, Version 1.1.1

### 2.2 Definitions

In this Bluetooth document, the definitions from [1] and [2] apply.

Certain terms that were identified as inappropriate have been replaced. For a list of the original terms and their replacement terms, see the Appropriate Language Mapping Tables document [12].

### 2.3 Acronyms and abbreviations

In this Bluetooth document, the definitions, acronyms, and abbreviations from [1] and [2] apply.

Acronyms and abbreviations	Definition
CP Sensor	Cycling Power Sensor

Table 2.1: Acronyms and abbreviations

## 3 Test Suite Structure (TSS)

### 3.1 Overview

The Cycling Power Profile requires the presence of GAP, SM, and GATT. This is illustrated in [Figure 3.1](#).

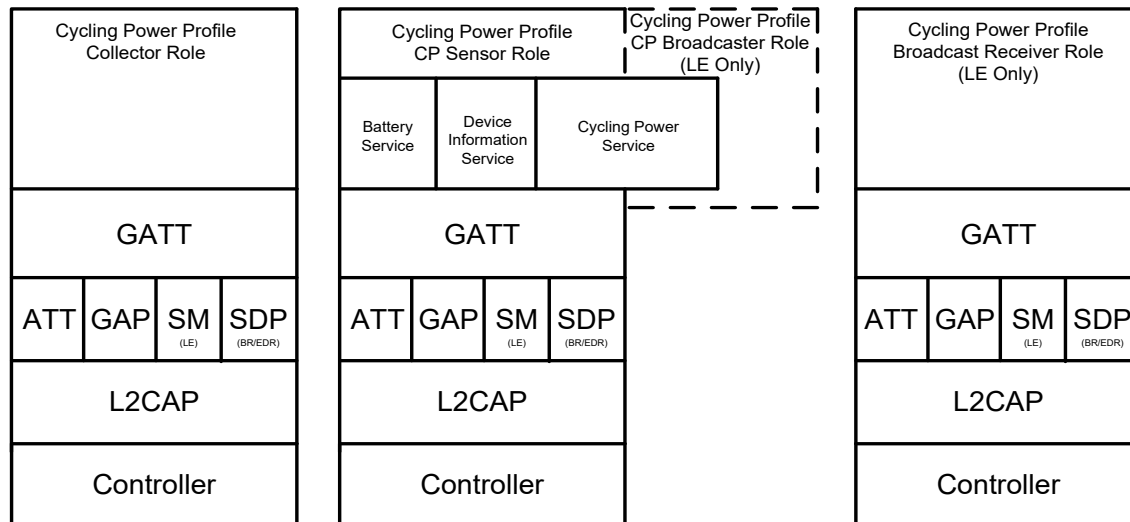

Figure 3.1: Cycling Power test Model

### 3.2 Test Strategy

The test objectives are to verify the functionality of the Cycling Power Profile within a Bluetooth Host and enable interoperability between Bluetooth Hosts on different devices. The testing approach covers mandatory and optional requirements in the specification and matches these to the support of the IUT as described in the ICS. Any defined test herein is applicable to the IUT if the ICS logical expression defined in the Test Case Mapping Table (TCMT) evaluates to true.

The test equipment provides an implementation of the Radio Controller and the parts of the Host needed to perform the test cases defined in this Test Suite. A Lower Tester acts as the IUT's peer device and interacts with the IUT over-the-air interface. The configuration, including the IUT, needs to implement similar capabilities to communicate with the test equipment. For some test cases, it is necessary to stimulate the IUT from an Upper Tester. In practice, this could be implemented as a special test interface, a Man Machine Interface (MMI), or another interface supported by the IUT.

Some test cases in this Test Suite emulate simultaneous connection with two Sensors and therefore require two Lower Testers that are independent of each other.

This Test Suite contains Valid Behavior (BV) tests complemented with Invalid Behavior (BI) tests where required. The test coverage mirrored in the Test Suite Structure is the result of a process that started with catalogued specification requirements that were logically grouped and assessed for testability enabling coverage in defined test purposes.

### 3.2.1 Test database requirements

The following requirements apply to the set of databases used by the Lower Tester for testing of GATT Client functionality:

- The Lower Tester includes one instantiation of each of the services used by this profile, including all defined characteristics.
- Each service instantiation also contains two «future» characteristics.
  - If possible, with one inserted before the first characteristic defined
  - If possible, with one appended after the last characteristic defined
- Each «future» characteristic has a 16-bit UUID randomly selected from unassigned UUIDs at the time of the test.

### 3.3 Test groups

The following test groups have been defined:

- Generic GATT Integrated Tests
- Discovery of Services and Characteristics
- Features
- Service Procedures

## 4 Test cases (TC)

### 4.1 Introduction

#### 4.1.1 Test case identification conventions

Test cases are assigned unique identifiers per the conventions in [1]. The convention used here is: **<spec abbreviation>/<IUT role>/<class>/<feat>/<func>/<subfunc>/<cap>/<xx>-<nn>-<y>**.

Additionally, testing of this specification includes tests from the GATT Test Suite [5] referred to as Generic GATT Integrated Tests (GGIT); when used, the test cases in GGIT are referred to through a TCID string using the following convention:

**<spec abbreviation>/<IUT role>/<GGIT test group>/< GGIT class >/<xx>-<nn>-<y>**.

Identifier Abbreviation	Spec Identifier <spec abbreviation>
CPP	Cycling Power Profile
Identifier Abbreviation	Role Identifier <IUT role>
COL	Collector Role
SEN	CP Sensor Role and CP Broadcaster Role
Identifier Abbreviation	Reference Identifier <GGIT test group>
CGGIT	Client Generic GATT Integrated Tests
SGGIT	Server Generic GATT Integrated Tests
Identifier Abbreviation	Reference Identifier <GGIT class>
CHA	Characteristic
ISFC	Indication Supported Features Characteristic
SDPNF	SDP Record Not Found
SER	Service
Identifier Abbreviation	Class identifier <class>
CPD	Discovery of Services and Characteristics
CPF	Features
OBS	CP Observer Role
SPE	Service Procedure – Error Handling
SPM	Service Procedure – Mask Characteristic Content
SPO	Service Procedure – Start Offset Compensation
SPP	Service Procedures – Handle CP Sensor Parameters
SPS	Service Procedures – Set Cumulative Value

Table 4.1: CPP TC feature naming conventions

#### 4.1.2 Conformance

When conformance is claimed for a particular specification, all capabilities are to be supported in the specified manner. The mandated tests from this Test Suite depend on the capabilities to which conformance is claimed.

The Bluetooth Qualification Program may employ tests to verify implementation robustness. The level of implementation robustness that is verified varies from one specification to another and may be revised for cause based on interoperability issues found in the market.



Such tests may verify:

- That claimed capabilities may be used in any order and any number of repetitions not excluded by the specification
- That capabilities enabled by the implementations are sustained over durations expected by the use case
- That the implementation gracefully handles any quantity of data expected by the use case
- That in cases where more than one valid interpretation of the specification exists, the implementation complies with at least one interpretation and gracefully handles other interpretations
- That the implementation is immune to attempted security exploits

A single execution of each of the required tests is required to constitute a Pass verdict. However, it is noted that to provide a foundation for interoperability, it is necessary that a qualified implementation consistently and repeatedly pass any of the applicable tests.

In any case, where a member finds an issue with the test plan generated by the Bluetooth SIG qualification tool, with the test case as described in the Test Suite, or with the test system utilized, the member is required to notify the responsible party via an erratum request such that the issue may be addressed.

### 4.1.3 Pass/Fail verdict conventions

Each test case has an Expected Outcome section. The IUT is granted the Pass verdict when all the detailed pass criteria conditions within the Expected Outcome section are met.

The convention in this Test Suite is that, unless there is a specific set of fail conditions outlined in the test case, the IUT fails the test case as soon as one of the pass criteria conditions cannot be met. If this occurs, the outcome of the test is a Fail verdict.

## 4.2 Setup preambles

The procedures defined in this section are used to achieve specific conditions on the IUT and the test equipment within the tests defined in this document. The preambles here are commonly used to establish initial conditions.

### 4.2.1 ATT Bearer on LE Transport

- Preamble Procedure
  1. Establish an LE transport connection between the IUT and the Lower Tester.
  2. Establish an L2CAP channel 0x0004 between the IUT and the Lower Tester over that LE transport.

### 4.2.2 ATT Bearer on BR/EDR Transport

- Preamble Procedure
  1. Establish a BR/EDR transport connection between the IUT and the Lower Tester.
  2. Establish several L2CAP channels (PSM 0x001F) between the IUT and the Lower Tester over that BR/EDR transport.

### 4.2.3 Collector: Configure CP Sensor for use with Cycling Power Control Point

- Preamble Purpose

This preamble procedure specifies how the Collector IUT configures the CP Sensor for use with Cycling Power Control Point and is valid for LE and BR/EDR transports.

- Preamble Procedure

1. Establish an ATT Bearer connection between the Lower Tester and IUT as described in Section 4.2.1 if using an LE transport or Section 4.2.2 if using a BR/EDR transport.
2. The handles of the Cycling Power Measurement, the Cycling Power Feature, the Sensor Location, the Cycling Power Control Point, and the Cycling Power Vector characteristics have been previously discovered by the Lower Tester during the test procedures in Section 4.3 or are known to the Lower Tester by other means.
3. The handles of the Client Characteristic Configuration descriptor of the Cycling Power Measurement characteristic and Cycling Power Control Point characteristic have been previously discovered by the Lower Tester during the test procedure in Section 4.3 or are known to the Lower Tester by other means.
4. The Lower Tester may perform a bonding procedure. If previously bonded, enable encryption if not already enabled.
5. The Cycling Power Measurement characteristic is configured for notifications.
6. The Cycling Power Control Point characteristic is configured for indications.
7. The Cycling Power Vector characteristic, if discovered, is configured for notifications.

### 4.2.4 LE Collector: Scan to detect Sensor Connectable Advertisements and initiate a connection

- Preamble Purpose

This LE preamble procedure specifies how the Collector IUT scans for CP Sensor connectable advertisements for the case when a Sensor has new data available.

- Reference

[3] 7.2

[2] 9.3.3 and 9.3.4

- Preamble Procedure

1. Configure the Collector IUT to accept commands from the Upper Tester to receive data from the CP Sensor (Lower Tester).
2. The Upper Tester commands the Collector IUT to initiate a connection and the IUT starts scanning.
3. The CP Sensor (Lower Tester) advertises to the Collector IUT either using:
  - ALT 1: GAP Directed Connectable Mode (send ADV\_DIRECT\_IND packets); or
  - ALT 2: GAP Undirected Connectable Mode (send ADV\_IND packets).
4. The Lower Tester waits for responses from the Collector IUT.
5. The Collector IUT sends a CONNECT\_REQ and an optionally empty PDU to the Lower Tester.

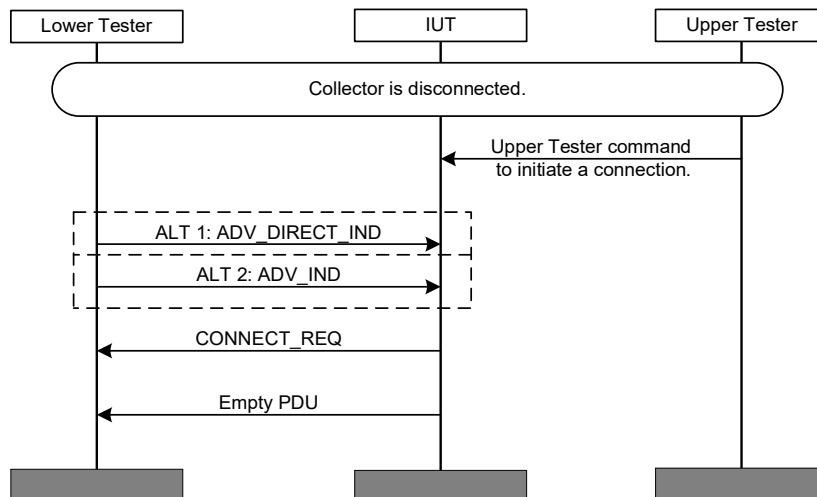

Figure 4.1: Cycling Power test model MSC

#### 4.2.5 LE CP Observer: Scan to detect Sensor Non-Connectable Advertisements

- Preamble Purpose

This LE preamble procedure specifies how the CP Observer IUT scans for CP Sensor (Lower Tester) non-connectable advertisements for the case when a CP Sensor is broadcasting the Cycling Power Measurement characteristic value.

- Reference

[3] 7

- Preamble Procedure

1. Configure the CP Observer IUT to accept commands from the Upper Tester to receive data from the CP Sensor (Lower Tester).
2. The Upper Tester commands the CP Observer IUT to scan with an appropriate filter policy (e.g., the address of the Lower Tester).
3. The CP Sensor (Lower Tester) advertises using undirected non-connectable advertisement including the Cycling Power Measurement characteristic to be broadcasted as defined in [6].

#### 4.2.6 BR/EDR Collector

##### 4.2.6.1 Unbonded Devices

- Preamble Purpose

This BR/EDR preamble procedure specifies how the Collector IUT scans for the CP Sensor for the case when a CP Sensor has new records available.

- Reference

[3] 7.3

[2] 4.1 and 4.2

- Preamble Procedure

1. Configure the Collector IUT to accept commands to receive data from the CP Sensor (Lower Tester).
2. Put the CP Sensor in General Discoverable mode.

3. The Upper Tester commands the Collector IUT to initiate a connection and the IUT starts scanning.
4. The CP Sensor (Lower Tester) exposes the SDP record for the Cycling Power Service.
5. The Collector IUT validates the SDP record and establishes a connection to the CP Sensor.
6. The Collector uses the GAP General Discovery procedure to discover a CP Sensor to establish a connection to a CP Sensor.

#### 4.2.6.2 Bonded Devices

- Preamble Purpose

In the case of BR/EDR, either a CP Sensor or Collector could initiate a connection when they are bonded. The device initiating the connection becomes a Central and is referred to herein as a paging device, and the device accepting the connection becomes a Peripheral and is referred to herein as a page scanning device.

This BR/EDR preamble procedure specifies how a paging device connects to a page scanning device.

- Reference

[3] 7.3

[2] 4.1, 4.2

- Preamble Procedure

1. Configure the Collector IUT to accept commands to receive data from the CP Sensor (Lower Tester).
2. Put the page scanning device in the connectable mode to accept a connection from the paging device.
3. The connection is initiated by the paging device.
4. The page scanning device exposes the SDP record for the Cycling Power Service.
5. The paging device validates the SDP record and establishes a connection to the page scanning device.
6. The paging device uses the GAP Link Establishment Procedure to connect to any bonded device.

### 4.3 Generic GATT Integrated Tests

Execute the Generic GATT Integrated Tests defined in Section 6.3, Server test procedures (SGGIT), and Section 6.4, Client test procedures (CGGIT), in [5] using Table 4.2 below as input:

TCID	Service / Characteristic / Descriptor	Reference	Properties	Value Length (Octets)	Service Type
CPP/COL/CGGIT/SER/BV-01-C [Service GGIT – Cycling Power Service]	Cycling Power Service	[3] 4.2	-	-	Primary Service
CPP/COL/CGGIT/CHA/BV-01-C [Characteristic GGIT – Cycling Power Feature]	Cycling Power Feature Characteristic	[3] 4.3.1	0x22 (Read, Indicate)	4	-
CPP/COL/CGGIT/CHA/BV-02-C [Characteristic GGIT – Cycling Power Measurement]	Cycling Power Measurement Characteristic	[3] 3.1	0x11 (Broadcast, Notify)	Skip	-
CPP/COL/CGGIT/CHA/BV-03-C [Characteristic GGIT – Sensor Location]	Sensor Location Characteristic	[3] 4.3.1	0x02 (Read)	1	-
CPP/COL/CGGIT/CHA/BV-04-C [Characteristic GGIT – Cycling Power Control Point]	Cycling Power Control Point Characteristic	[3] 4.3.1	0x20 (Indicate)	Skip	-
CPP/COL/CGGIT/CHA/BV-05-C [Characteristic GGIT – Cycling Power Vector]	Cycling Power Vector Characteristic	[3] 4.3.1	0x10 (Notify)	Skip	-
CPP/COL/CGGIT/SER/BV-02-C [Service GGIT – Device Information Service]	Device Information Service	[3] 4.2	-	-	Primary Service
CPP/COL/CGGIT/SER/BV-03-C [Service GGIT – Battery Service]	Battery Service	[3] 4.2	-	-	Primary Service
CPP/COL/CGGIT/CHA/BV-06-C [Characteristic GGIT – Battery Level]	Battery Level Characteristic	[3] 4.10	0x12 (Read, Notify)	1	-
CPP/SEN/SGGIT/SDPNF/BV-01-C [Not discoverable over BR/EDR – Cycling Power Service]	Cycling Power Service	[3] 2.5	-	--	-

Table 4.2: Input for the GGIT Client test procedure



### 4.3.1 Generic GATT Indication Supported Features characteristic

Execute the Generic GATT Indication Supported Features characteristic tests defined in Section 6.4, Client test procedures (CGGIT), in [5] using Table 4.3 below as input:

TCID	Characteristic	Reference	TC Configuration
CPP/COL/CGGIT/ISFC/BV-01-C [Characteristic GGIT – Cycling Power Feature indication]	Cycling Power Feature	[13] 4.4	N/A

Table 4.3: Input for the GGIT Indication Supported Features Characteristic tests



## 4.4 Discover Services and Characteristics

The procedures defined in this test group verify IUT's ability to discover the services and characteristics exposed by a CP Sensor (Lower Tester).

### CPP/COL/CPD/BV-15-C [Discover Device Information Service Characteristics]

- Test Purpose

Verify that a Collector IUT can discover all characteristics of a Device Information Service supported by the IUT.

- Reference

[3] 4.3.2

- Initial Condition

- Via IXIT [10] the IUT manufacturer specifies all characteristics of the Device Information Service supported by the IUT.
- Run the preamble procedure to enable the Collector to initiate a connection to a CP Sensor included in Section 4.2.4 if using an LE transport or 4.2.6 if using a BR/EDR transport.
- The IUT has the handle range for the instantiation of the Device Information Service contained in the Lower Tester. The Device Information Service contains one or more characteristics. DIS was previously discovered using GATT-based methods as in CPP/COL/CGGIT/SER/BV-02-C [Service GGIT – Device Information Service].

- Test Procedure

1. The Upper Tester issues a command to the IUT to discover all characteristics of the Device Information Service supported by the IUT.
2. The IUT executes either alternative 2A or 2B.

Alternative 2A (Discover All Characteristics of a Service sub-procedure):

2A: Discover All Characteristics of a Service, using the specified handle range, with the Lower Tester instantiating the database specified in Section 3.2.1.

Alternative 2B (Discover Characteristics by UUID sub-procedure):

2B: Discover Characteristics by UUID, using each of the UUIDs for the characteristics of the Device Information Service supported by the IUT, with the Lower Tester instantiating the database specified in Section 3.2.1.

- Expected Outcome

Pass verdict

For each characteristic supported by the IUT contained in the Lower Tester's instantiation of the Device Information Service, the IUT reports an attribute handle/value pair for each characteristic specified in the IXIT [10] to the Upper Tester.

## CPP/COL/CPD/BV-16-C [Read Device Information Service Characteristics]

- Test Purpose
 

Verify that a Collector IUT can read all characteristics of a Device Information Service supported by the IUT.
- Reference
 

[3] 4.3.2 and 4.9
- Initial Condition
  - Via IXIT [10] the IUT manufacturer specifies all characteristics of the Device Information Service supported by the IUT.
  - Run the preamble procedure for the Collector to initiate a connection to a CP Sensor included in Section 4.2.4 if using an LE transport or 4.2.6 if using a BR/EDR transport.
  - The Lower Tester includes one instantiation of the Device Information Service [8] including all defined characteristics.
  - The IUT has previously executed the procedure included in CPP/COL/CPD/BV-15-C [Discover Device Information Service Characteristics], so it has the handle/value pairs for all characteristics of the Device Information Service supported by the IUT.
- Test Procedure
  1. For string based characteristics (i.e., Manufacturer Name String, Model Number String, Serial Number String, Hardware Revision String, Firmware Revision String and Software Revision String), this test is run twice and a disconnection may occur between the two tests. In the first pass, the string includes only character values in the ASCII printable range (i.e., 0x20 – 0x7E). In the second pass, the string includes character values outside the ASCII printable range. For System ID characteristic, the Manufacturer Identifier is set to 0xFFFE9ABCDE and Organizationally Unique Identifier is set to 0x123456. For 11073-20601 Regulatory Certification Data List characteristic, the Data field is set to 0x0000-0002-8008-0200-0001-0105-0008-0201-0012-0002. For PnP\_ID characteristic, the Vendor ID Source is set to 0x01, the Vendor ID is set to 0x006B, the Product ID is set to 0x1234 and the Product Version is set to 0x0102.
  2. The Upper Tester issues a command to the IUT to read all characteristics of the Device Information Service supported by the IUT.
  3. For each characteristic of the Device Information Service supported by the IUT, the IUT sends an ATT\_Read\_Request to the Lower Tester containing the handle specified by the Upper Tester.
  4. The IUT receives an ATT\_Read\_Response and reports the value to the Upper Tester.
- Expected Outcome
 

Pass verdict

For each characteristic contained in the Lower Tester's instantiation of the Device Information Service supported by the IUT, the IUT reports the characteristic value for all characteristics specified in the IXIT [10] to the Upper Tester, including:

For string-based characteristics, any printable or non-printable ASCII values.

For System ID characteristic, the Manufacturer Identifier and Organizationally Unique Identifier.

For 11073-20601 Regulatory Certification Data List characteristic, the IEEE 11073-20601 Regulatory Certification Data List (note that this value is defined in big endian format).

For PnP\_ID characteristic, the Vendor ID Source, the Vendor ID, the Product ID, and the Product Version.

## 4.5 Cycling Power Features

The procedures defined in this test group verify Cycling Power Sensor IUT implementation of the features defined in the Cycling Power Profile Specification [3] by a CP Sensor IUT and usage of the same features by a Collector IUT.

### CPP/SEN/CPF/BV-01-C [Cycling Power Service UUID in AD]

- Test Purpose

Verify that the Cycling Power Service UUID is included in AD (Advertising Data) from the CP Sensor IUT when using the LE Transport.

- Reference

[3] 3.1.1.1

- Initial Condition

- The IUT is powered on in GAP Discoverable Mode.
- The IUT is induced to generate Advertising Packets using preamble defined in Section 4.2.3.

- Test Procedure

The Lower Tester listens for Advertising Packets from the IUT.

- Expected Outcome

Pass verdict

At least, one received Advertising Packet contains the defined Service UUID for «Cycling Power Service».

### CPP/SEN/CPF/BV-02-C [Local Name included in AD or Scan Response]

- Test Purpose

Verify that the Local Name is included in AD (Advertising Data) or Scan Response data from the CP Sensor IUT when using the LE Transport.

- Reference

[3] 3.1.1.2

- Initial Condition

- The IUT is powered on in GAP Discoverable Mode.
- The IUT is induced to generate Advertising Packets using the preamble in Section 4.2.3.

- Test Procedure

The Lower Tester listens for Advertising Packets from the IUT. When the Lower Tester receives an Advertising Packet from IUT, it sends a Scan Request to the IUT. Then the Lower Tester listens for a Scan Response from the IUT.

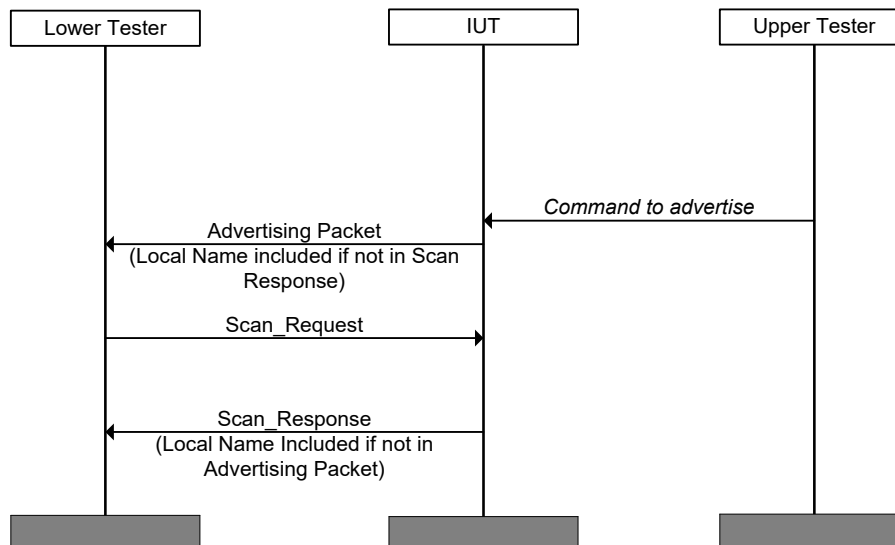

Figure 4.2: Local Name included in AD or Scan Response MSC

- Expected Outcome

Pass verdict

The IUT sends an Advertising packet and a Scan Response packet.

The IUT includes the Local Name in either the Advertising packet or Scan Response packet, but not both.

### CPP/SEN/CPF/BV-03-C [Appearance included in AD or Scan Response]

- Test Purpose

Verify that the Appearance characteristic value is included in AD (Advertising Data) or Scan Response data from the CP Sensor IUT when using the LE Transport.

- Reference

[3] 3.1.1.4

- Initial Condition

- The IUT is powered on in GAP Discoverable Mode.
- The IUT is induced to generate Advertising Packets using the preamble in Section 4.2.3.

- Test Procedure

The Lower Tester listens for Advertising Packets from the IUT. When the Lower Tester receives an Advertising Packet from IUT, it sends a Scan Request to the IUT. Then the Lower Tester listens for a Scan Response from the IUT.

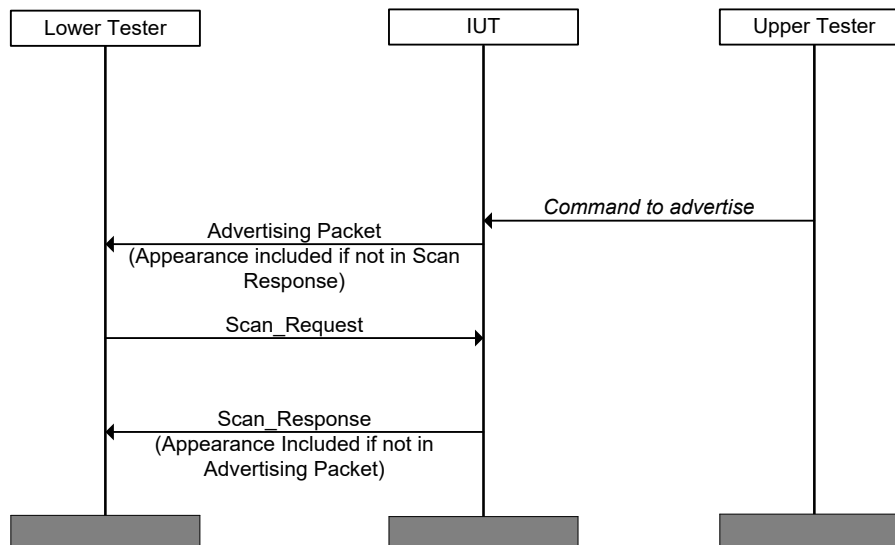

Figure 4.3: Appearance included in AD or Scan Response MSC

- Expected Outcome

Pass verdict

The IUT sends an Advertising packet and a Scan Response packet.

The IUT includes the Appearance characteristic value in either the Advertising packet or Scan Response packet, but not both.

### CPP/COL/CPF/BI-01-C [Read Cycling Power Feature characteristic with reserved value]

- Test Purpose

Verify that the Collector IUT can read the Cycling Power Feature characteristic from a CP Sensor, and ignore reserved bits.

- Reference

[3] 4.4

- Initial Condition

- A preamble procedure defined in Section 4.2.4 if using an LE transport or 4.2.6 if using a BR/EDR transports used to set up the transport and L2CAP channel and initiate connection to a CP Sensor.
- The Upper Tester knows the handle of a Cycling Power Feature characteristic contained in the Lower Tester.

- Test Procedure

1. Send a command from Upper Tester to request the IUT to read a Cycling Power Feature Characteristic from the Lower Tester, e.g., *CPP\_ReadRequest* (handle, value).
2. After receipt of the expected result by the Lower Tester from the IUT, send an *ATT\_Read\_Response* (0x0B) from the Lower Tester to the IUT containing values with some reserved bits set to 1.

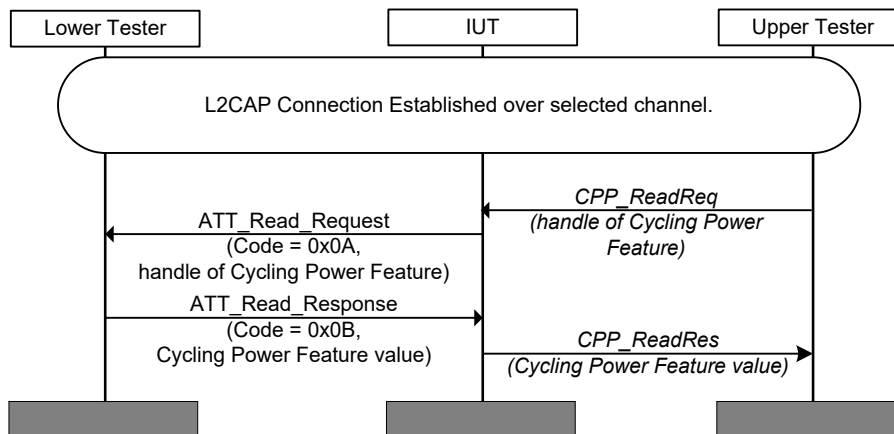

Figure 4.4: Read Cycling Power Feature characteristic with reserved value MSC

- Expected Outcome

Pass verdict

The IUT sends a correctly formatted *ATT\_Read\_Request* (0x0A) to the Lower Tester, containing the handle specified by the Upper Tester.

The IUT receives the response from the Lower Tester, ignores the reserved bits and continues to operate as if the reserved bits were not set.

### CPP/COL/CPF/BV-05-C [Configure Cycling Power Measurement for Notification]

- Test Purpose

Verify that the Collector IUT can configure a CP Sensor (Lower Tester) to notify Cycling Power Measurement characteristics.

- Reference

[3] 4.5

- Initial Condition

- A preamble procedure defined in Section 4.2.4 if using an LE transport or 4.2.6 if using a BR/EDR transport is used to set up the transport and L2CAP channel and initiate connection to a CP Sensor.
- The IUT has discovered the Client Characteristic Configuration Descriptor for a Cycling Power Measurement characteristic contained in the Lower Tester.

- Test Procedure

The Upper Tester sends a command to the IUT to configure the CP Sensor to send Cycling Power Measurement characteristics.

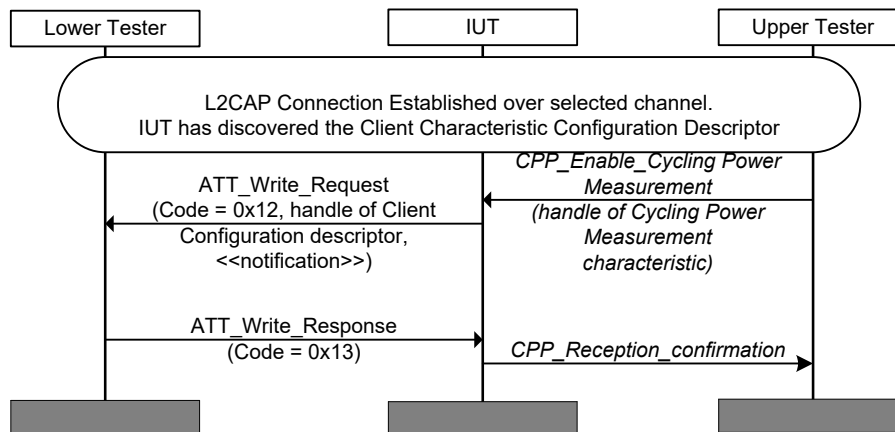

Figure 4.5: Configure Cycling Power Measurement for Notification MSC

- Expected Outcome

#### Pass verdict

The IUT sends a correctly formatted *ATT\_Write\_Request* (0x12) to the Lower Tester, with the handle set to that of the Client Characteristic Configuration Descriptor for a Cycling Power Measurement characteristic, and the value set to «notification».

### CPP/COL/CPF/BV-06-C [Receive Cycling Power Measurement Notifications]

- Test Purpose

Verify that the Collector IUT can receive notifications of the Cycling Power Measurement Characteristic, including all variants.

- Reference

[3] 4.5

- Initial Condition

- A preamble procedure defined in Section 4.2.4 if using an LE transport or 4.2.6 if using a BR/EDR transport is used to set up the transport and L2CAP channel and initiate connection to a CP Sensor.
- The IUT has executed the procedure included in CPP/COL/CPF/BV-05-C [Configure Cycling Power Measurement for Notification], which configures it to expect Cycling Power Measurement Notifications.
- The IUT knows the handle of the Cycling Power Measurement characteristic.

- Test Procedure

1. The Lower Tester sends an *ATT\_Handle\_Value\_Notification* containing a Cycling Power Measurement characteristic value to the IUT.
2. The Lower Tester sends one Cycling Power Measurement characteristic notification for each Test Pattern shown in the following table. For each Test Pattern, the value of the Flags field is shown along with the corresponding pass criteria.

Test Pattern	Flags Field Value (bit15 ... bit0)	Pass Criteria
1	00000000 – 00000001	Only optional field present is Pedal Power Balance with the Pedal Power Balance Reference set to “Unknown”.
2	00000000 – 00000011	Only optional field present is Pedal Power Balance with the Pedal Power Balance Reference set to “Left”.
3	00000000 – 00000100	Only optional field present is Accumulated Torque with the Accumulated Torque Source set to “Wheel based”.
4	00000000 – 00001100	Only optional field present is Accumulated Torque with the Accumulated Torque Source set to “Crank based”.
5	00000000 – 00010000	Only optional fields present are Cumulative Wheel Revolutions and Last Wheel Event Time.
6	00000000 – 00100000	Only optional fields present are Cumulative Crank Revolutions and Last Crank Event Time.
7	00000000 – 01000000	Only optional fields present are Maximum Force Magnitude and Minimum Force Magnitude.
8	00000000 – 10000000	Only optional fields present are Maximum Torque Magnitude and Minimum Torque Magnitude.
9	00000001 – 00000000	Only optional fields present are Maximum Angle and Minimum Angle.
10	00000010 – 00000000	Only optional field present is Top Dead Spot.
11	00000100 – 00000000	Only optional field present is Bottom Dead Spot.
12	00001000 – 00000000	Only optional field present is Accumulated Energy.
13	00010000 – 00000000	No optional field present. Offset Compensation Indicator set to True.

Table 4.4: Receive Cycling Power Measurement Notifications

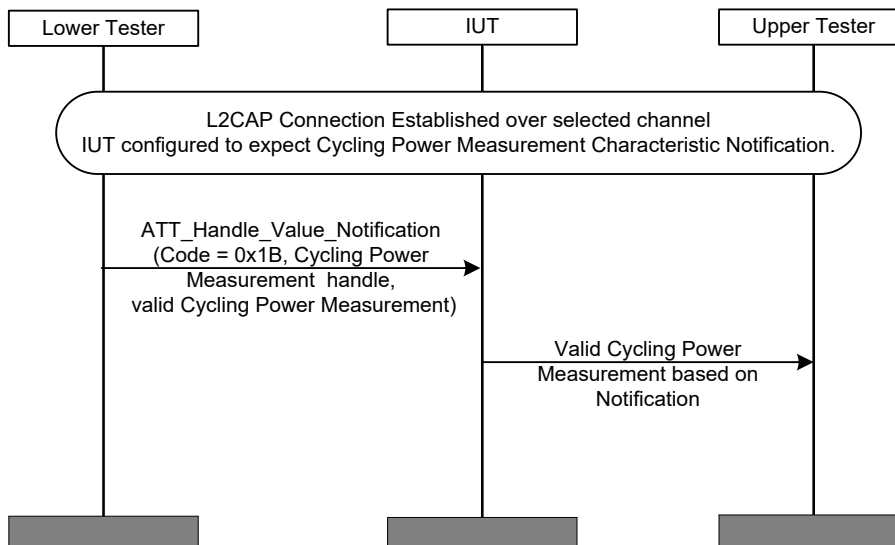

Figure 4.6: Receive Cycling Power Measurement Notifications MSC

- Expected Outcome

Pass verdict

The IUT is able to correctly parse the received Cycling Power Measurement values according to the pass criteria in the table above. The reported Cycling Power Measurement field values match the ones sent by the Lower Tester.

## CPP/COL/CPF/BV-07-C [Receive Cycling Power Measurement Notifications – Accumulated Torque Roll Over]

- Test Purpose

Verify that the Collector IUT can receive notifications of the Cycling Power Measurement Characteristic and properly calculate accumulated torque when the value of the Accumulated Torque field rolls over.

- Reference

[3] 4.5

- Initial Condition

- A preamble procedure defined in Section 4.2.4 if using an LE transport or 4.2.6 if using a BR/EDR transport is used to set up the transport and L2CAP channel and initiate connection to a CP Sensor.
- The IUT has executed the procedure included in CPP/COL/CPF/BV-05-C [Configure Cycling Power Measurement for Notification], which configures it to expect Cycling Power Measurement Notifications.
- The IUT knows the handle of the Cycling Power Measurement characteristic.

- Test Procedure

1. Perform an action on the Lower Tester that will induce setting the Accumulated Torque values in the table below such as to induce an Accumulated Torque rollover event.

	Accumulated Torque Value [1/32 Nm]	Expected Accumulated Torque at IUT [Nm]
1	64960 (0xFDC0)	2030.0
2	65280 (0xFF00)	2040.0
3	64 (0x0040)	2050.0
4	384 (0x0180)	2060.0
5	704 (0x02C0)	2070.0

Table 4.5: Receive Cycling Power Measurement Notifications – Accumulated Torque Rollover

2. The Lower Tester sends five *ATT\_Handle\_Value\_Notifications* containing a Cycling Power Measurement characteristic value to the IUT (corresponding to the sequence of rows in the table above) that simulate a regular and consistent torque accumulation as on a bike including an Accumulated Torque field rollover event.
3. The IUT responds correctly when the Accumulated Torque value rolls over.

- Expected Outcome

### Pass verdict

The IUT receives notifications of Cycling Power Measurement values from the Lower Tester that include Accumulated Torque field.

The IUT correctly calculates consistent accumulated torque values before and after the rollover event.

## CPP/COL/CPF/BV-08-C [Receive Cycling Power Measurement Notifications – Last Wheel Event Time Roll Over]

- Test Purpose

Verify that the Collector IUT can receive notifications of the Cycling Power Measurement Characteristic and properly calculate speed when the value of the Last Wheel Event Time field rolls over.

- Reference

[3] 4.5

- Initial Condition

- A preamble procedure defined in Section 4.2.4 if using an LE transport or 4.2.6 if using a BR/EDR transport is used to set up the transport and L2CAP channel and initiate connection to a CP Sensor.
- The IUT has executed the procedure included in CPP/COL/CPF/BV-05-C [Configure Cycling Power Measurement for Notification], which configures it to expect Cycling Power Measurement Notifications.
- The IUT knows the handle of the Cycling Power Measurement characteristic.

- Test Procedure

1. Configure the IUT for Instantaneous Speed calculation with a wheel circumference of 210 centimeters. An IUT may be configured to an alternative value for calculation. Any alternative value is noted and included in testing evidence to support the calculated value of Instantaneous Speed.
2. Perform an action on the Lower Tester that will induce setting the Cumulative Wheel Revolutions values and the Last Wheel Event Time values in the table below such as to induce a Last Wheel Event Time rollover event.

	Cumulative Wheel Revolution	Last Wheel Event Time [1/2048s]	Expected Instantaneous Speed at IUT [km/h]
1	1000	63000	N/A
2	1008	65048	60.48
3	1016	1560	60.48
4	1024	3608	60.48
5	1032	5656	60.48

Table 4.6: Receive Cycling Power Measurement Notifications – Last Wheel Event Time Rollover

3. The Lower Tester sends five *ATT\_Handle\_Value\_Notifications* containing a Cycling Power Measurement characteristic value to the IUT (corresponding to the sequence of rows in the table above) that simulate a regular and consistent wheel rotation as on a bike including a Last Wheel Event Time field rollover event.
4. The IUT responds correctly when the Last Wheel Event Time value rolls over.

- Expected Outcome

Pass verdict

The IUT receives notifications of Cycling Power Measurement values from the Lower Tester that include Wheel Revolution Data.

IUT correctly calculates consistent instantaneous speed values before and after the rollover event.

### CPP/COL/CPF/BV-09-C [Receive Cycling Power Measurement Notifications – Cumulative Crank Revolutions Roll Over]

- Test Purpose

Verify that the Collector IUT can receive notifications of the Cycling Power Measurement Characteristic and properly calculate cadence when the value of the Cumulative Crank Revolutions field rolls over.

- Reference

[3] 4.5

- Initial Condition

- A preamble procedure defined in Section 4.2.4 if using an LE transport or 4.2.6 if using a BR/EDR transport is used to set up the transport and L2CAP channel and initiate connection to a CP Sensor.
- The IUT has executed the procedure included in CPP/COL/CPF/BV-05-C [Configure Cycling Power Measurement for Notification], which configures it to expect Cycling Power Measurement Notifications.
- The IUT knows the handle of the Cycling Power Measurement characteristic.

- Test Procedure

1. Perform an action on the Lower Tester that will induce setting the Cumulative Crank Revolutions values and the Last Crank Event Time values in the table below such as to induce a Cumulative Crank Revolutions rollover event.

	Cumulative Crank Revolutions	Last Crank Event Time [1/1024s]	Expected Instantaneous Cadence [rpm]
1	65534	9300	N/A
2	65535	9982	90
3	1	11348	90
4	2	12030	90
5	4	13396	90

Table 4.7: Receive Cycling Power Measurement Notifications – Cumulative Crank Revolutions Rollover

2. The Lower Tester sends five *ATT\_Handle\_Value\_Notifications* containing a Cycling Power Measurement characteristic value to the IUT (corresponding to the sequence of rows in the table above) that simulate a regular and consistent crank rotation as on a bike including a Cumulative Crank Revolutions field rollover event.
3. The IUT responds correctly when the Cumulative Crank Revolutions value rolls over.

- Expected Outcome

Pass verdict

The IUT receives notifications of Cycling Power Measurement values from the Lower Tester that include Crank Revolution Data.

The IUT correctly calculates consistent instantaneous cadence values before and after the rollover event.

### CPP/COL/CPF/BV-10-C [Receive Cycling Power Measurement Notifications – Last Crank Event Time Roll Over]

- Test Purpose

Verify that the Collector IUT can receive notifications of the Cycling Power Measurement Characteristic and properly calculate cadence when the value of the Last Crank Event Time field rolls over.

- Reference

[3] 4.5

- Initial Condition

- A preamble procedure defined in Section 4.2.4 if using an LE transport or 4.2.6 if using a BR/EDR transport is used to set up the transport and L2CAP channel and initiate connection to a CP Sensor.
- The IUT has executed the procedure included in CPP/COL/CPF/BV-05-C [Configure Cycling Power Measurement for Notification], which configures it to expect Cycling Power Measurement Notifications.
- The IUT knows the handle of the Cycling Power Measurement characteristic.

- Test Procedure

1. Perform an action on the Lower Tester that will induce setting the Cumulative Crank Revolutions values and the Last Crank Event Time values in the table below such as to induce a Last Crank Event Time rollover event.

	Cumulative Crank Revolutions	Last Crank Event Time [1/1024s]	Expected Instantaneous Cadence [rpm]
1	0	64000	N/A
2	1	64682	90
3	3	512	90
4	4	1194	90
5	6	2560	90

Table 4.8: Receive Cycling Power Measurement Notifications – Last Crank Event Time Rollover

2. The Lower Tester sends five *ATT\_Handle\_Value\_Notifications* containing a Cycling Power Measurement characteristic value to the IUT (corresponding to the sequence of rows in the table above) that simulate a regular and consistent crank rotation as on a bike including a Last Crank Event Time field rollover event.
3. The IUT responds correctly when the Last Crank Event Time value rolls over.

- Expected Outcome

Pass verdict

The IUT receives notifications of Cycling Power Measurement values from the Lower Tester that include Crank Revolution Data.

The IUT correctly calculates consistent instantaneous cadence values before and after the rollover event.

### CPP/COL/CPF/BV-11-C [Receive Cycling Power Measurement Notifications – Accumulated Energy Roll Over]

- Test Purpose

Verify that the Collector IUT can receive notifications of the Cycling Power Measurement Characteristic and properly calculate accumulated energy when the value of the Accumulated Energy field rolls over.

- Reference

[3] 4.5

- Initial Condition

- A preamble procedure defined in Section 4.2.4 if using an LE transport or 4.2.6 if using a BR/EDR transport is used to set up the transport and L2CAP channel and initiate connection to a CP Sensor.
- The IUT has executed the procedure included in CPP/COL/CPF/BV-05-C [Configure Cycling Power Measurement for Notification], which configures it to expect Cycling Power Measurement Notifications.
- The IUT knows the handle of the Cycling Power Measurement characteristic.

- Test Procedure

1. Perform an action on the Lower Tester that will induce setting the Accumulated Energy values in the table below such as to induce an Accumulated Energy rollover event.

	Accumulated Energy Value [kJ]	Expected Accumulated Energy at IUT [kJ]
1	65532	65532
2	65534	65534
3	0	65536
4	2	65538
5	4	65540

Table 4.9: Receive Cycling Power Measurement Notifications – Accumulated Energy Rollover

2. The Lower Tester sends five *ATT\_Handle\_Value\_Notifications* containing a Cycling Power Measurement characteristic value to the IUT (corresponding to the sequence of rows in the table above) that simulate a regular and consistent energy accumulation as on a bike including an Accumulated Energy field rollover event.
3. The IUT responds correctly when the Accumulated Energy value rolls over.

- Expected Outcome

Pass verdict

The IUT receives notifications of Cycling Power Measurement values from the Lower Tester that include Accumulated Energy field.

The IUT correctly calculates consistent accumulated energy values before and after the rollover event.

### CPP/COL/CPF/BV-12-C [Receive Cycling Power Measurement Notifications – Wheel Revolution Data After Link Loss]

- Test Purpose

Verify that the Collector IUT can receive notifications of the Cycling Power Measurement Characteristic that contain Wheel Revolution Data and that it properly recovers following a link loss.

- Reference

[3] 4.5

- Initial Condition

- A preamble procedure defined in Section 4.2.4 if using an LE transport or 4.2.6 if using a BR/EDR transport is used to set up the transport and L2CAP channel and initiate connection to a CP Sensor.
- The IUT has executed the procedure included in CPP/COL/CPF/BV-05-C [Configure Cycling Power Measurement for Notification], which configures it to expect Cycling Power Measurement Notifications.
- The IUT knows the handle of the Cycling Power Measurement characteristic.

- Test Procedure

- Configure the IUT for Instantaneous Speed calculation with a wheel circumference of 210 centimeters. An IUT may be configured to an alternative value for calculation. Any alternative value is noted and included in testing evidence to support the calculated value of Instantaneous Speed.
- Perform an action on the Lower Tester that will induce setting the Cumulative Wheel Revolutions values and the Last Wheel Event Time values in the following table.

	Cumulative Wheel Revolution	Last Wheel Event Time [1/2048s]	Expected Instantaneous Speed at IUT [km/h]
1	1000	1200	N/A
2	1008	3248	60.48
Link Loss and Reconnection (simulated for 10 seconds)			
3	1088	23728	60.48
4	1096	25776	60.48
5	1104	27824	60.48

Table 4.10: Receive Cycling Power Measurement Notifications – Wheel Revolution Data After Link Loss

- The Lower Tester sends two *ATT\_Handle\_Value\_Notifications* containing a Cycling Power Measurement characteristic value to the IUT (corresponding to the sequence of rows 1 and 2 in

the table above) that simulate a regular and consistent wheel rotation as on a bike for several seconds.

4. Perform an action on the Lower Tester that will cause the link to be lost for several seconds while continuing to simulate wheel rotation for several seconds at the IUT.
  5. Perform an action on the Lower Tester that allows the link to be restored.
  6. The Lower Tester sends the three remaining *ATT\_Handle\_Value\_Notifications* containing a Cycling Power Measurement characteristic value to the IUT (corresponding to the sequence of rows 3, 4 and 5 in the table above) that simulate a regular and consistent wheel rotation as on a bike for several seconds.
  7. The IUT responds correctly during the link loss and after the link is restored.
- Expected Outcome

Pass verdict

The IUT receives notifications of Cycling Power Measurement values from the Lower Tester that include Wheel Revolution Data.

The IUT correctly calculates consistent instantaneous speed values despite the link loss.

### CPP/COL/CPF/BV-13-C [Receive Cycling Power Measurement Notifications – Crank Revolution Data After Link Loss]

- Test Purpose
 

Verify that the Collector IUT can receive notifications of the Cycling Power Measurement Characteristic that contain Crank Revolution Data and that it properly recovers following a link loss.
- Reference
 

[3] 4.5
- Initial Condition
  - A preamble procedure defined in Section 4.2.4 if using an LE transport or 4.2.6 if using a BR/EDR transport is used to set up the transport and L2CAP channel and initiate connection to a CP Sensor.
  - The IUT has executed the procedure included in CPP/COL/CPF/BV-05-C [Configure Cycling Power Measurement for Notification], which configures it to expect Cycling Power Measurement Notifications.
  - The IUT knows the handle of the Cycling Power Measurement characteristic.
- Test Procedure
  1. Perform an action on the Lower Tester that will induce setting the Cumulative Crank Revolutions values and the Last Crank Event Time values in the following table.

	Cumulative Crank Revolutions	Last Crank Event Time [1/1024s]	Expected Instantaneous Cadence [rpm]
1	1000	10000	N/A
2	1001	10682	90
	Link Loss and Reconnection (simulated for 10 seconds)		
3	1016	20922	90

	Cumulative Crank Revolutions	Last Crank Event Time [1/1024s]	Expected Instantaneous Cadence [rpm]
4	1018	22288	90
5	1019	22970	90

Table 4.11: Receive Cycling Power Measurement Notifications – Crank Revolution Data After Link Loss

2. The Lower Tester sends two *ATT\_Handle\_Value\_Notifications* containing a Cycling Power Measurement characteristic value to the IUT (corresponding to the sequence of rows 1 and 2 in the table above) that simulate a regular and consistent crank rotation as on a bike for several seconds.
  3. Perform an action on the Lower Tester that will cause the link to be lost for several seconds while continuing to simulate crank rotation for several seconds at the IUT.
  4. Perform an action on the Lower Tester that allows the link to be restored.
  5. The Lower Tester sends the three remaining *ATT\_Handle\_Value\_Notifications* containing a Cycling Power Measurement characteristic value to the IUT (corresponding to the sequence of rows 3, 4, and 5 in the table above) that simulate a regular and consistent crank rotation as on a bike for several seconds.
  6. The IUT responds correctly during the link loss and after the link is restored.
- Expected Outcome

#### Pass verdict

The IUT receives notifications of Cycling Power Measurement values from the Lower Tester that include Crank Revolution Data.

The IUT correctly calculates consistent instantaneous cadence values despite the link loss.

### CPP/COL/CPF/BV-14-C [Receive Cycling Power Measurement Notifications – Reverse Wheel Revolution]

- Test Purpose
 

Verify that the Collector IUT is tolerant of CP Sensors that have the capability to decrement the Cumulative Wheel Revolutions field (e.g., when the wheel rotates in reverse).
- Reference
 

[3] 4.5
- Initial Condition
  - A preamble procedure defined in Section 4.2.4 if using an LE transport or 4.2.6 if using a BR/EDR transport is used to set up the transport and L2CAP channel and initiate connection to a CP Sensor.
  - The IUT has executed the procedure included in CPP/COL/CPF/BV-05-C [Configure Cycling Power Measurement for Notification], which configures it to expect Cycling Power Measurement Notifications.
  - The IUT knows the handle of the Cycling Power Measurement characteristic.

- Test Procedure
  1. Configure the IUT for Instantaneous Speed calculation with a wheel circumference of 210 centimeters. An IUT may be configured to an alternative value for calculation. Any alternative value is noted and included in testing evidence to support the calculated value of Instantaneous Speed.
  2. Perform an action on the Lower Tester that will induce setting the Cumulative Wheel Revolutions values and the Last Wheel Event Time values in the following table.

	Cumulative Wheel Revolution	Last Wheel Event Time [1/2048s]	Expected Instantaneous Speed at IUT [km/h]
1	1010	512	N/A
2	1012	2560	15.12
3	1008	4608	N/A
4	1006	6656	N/A
5	1007	8704	7.56
6	1009	10752	15.12
7	1011	12800	15.12

Table 4.12: Receive Cycling Power Measurement Notifications – Reverse Wheel Revolution

3. The Lower Tester sends six *ATT\_Handle\_Value\_Notifications* containing a Cycling Power Measurement characteristic value to the IUT (corresponding to the sequence of rows in the table above) that simulate an initial consistent forward rotation, followed by consistent reverse wheel rotation followed by consistent forward wheel rotation as on a bike.
  4. The IUT responds correctly when the Cumulative Wheel Revolutions value initially increases.
- Expected Outcome

#### Pass verdict

The IUT receives notifications of Cycling Power Measurement values from the Lower Tester that include Wheel Revolution Data.

The IUT correctly calculates consistent instantaneous speed values when the wheel rotates forward both before and after the Cumulative Wheel Revolutions value decreases.

Note that the behavior of the IUT while the wheel rotates in reverse corresponding to rows 3 and 4 is left to the implementation (e.g., the implementation may or may not calculate and display reverse speed during that time).

### CPP/COL/CPF/BV-15-C [Receive Cycling Power Measurement Notifications – Accumulated Torque Value Decreases]

- Test Purpose
 

Verify that the Collector IUT is tolerant of CP Sensors that have the capability to decrement the Accumulated Torque field (e.g., when the user pulls the pedals).

- Reference

[3] 4.5



- Initial Condition
  - A preamble procedure defined in Section 4.2.4 if using an LE transport or 4.2.6 if using a BR/EDR transport is used to set up the transport and L2CAP channel and initiate connection to a CP Sensor.
  - The IUT has executed the procedure included in CPP/COL/CPF/BV-05-C [Configure Cycling Power Measurement for Notification], which configures it to expect Cycling Power Measurement Notifications.
  - The IUT knows the handle of the Cycling Power Measurement characteristic.
- Test Procedure
  1. Perform an action on the Lower Tester that will induce setting the Accumulated Torque values in the following table such as to induce an Accumulated Torque rollover event (when the value decreases).

	Accumulated Torque Value [1/32 Nm]	Expected Accumulated Torque at IUT [Nm]
1	64960 (0xFDC0)	2030.0
2	65280 (0xFF00)	2040.0
3	64 (0x0040)	2050.0
4	384 (0x0180)	2060.0
5	704 (0x02C0)	2070.0
6	384 (0x0180)	2060.0
7	64 (0x0040)	2050.0
8	65280 (0xFF00)	2040.0
9	64960 (0xFDC0)	2030.0

Table 4.13: Receive Cycling Power Measurement Notifications – Accumulated Torque Value Decreases

2. The Lower Tester sends two *ATT\_Handle\_Value\_Notifications* containing a Cycling Power Measurement characteristic value to the IUT (corresponding to the sequence of rows the table above) that simulate a regular and consistent torque accumulation as on a bike for several seconds including two Accumulated Torque field rollover events.
  3. The IUT responds correctly when the Accumulated Torque value rolls over.
- Expected Outcome

Pass verdict

The IUT receives notifications of Cycling Power Measurement values from the Lower Tester that include Accumulated Torque field.

The IUT correctly calculates consistent accumulated torque values before and after the rollover event.

### CPP/COL/CPF/BI-02-C [Receive Cycling Power Measurement Notifications with reserved flags]

- Test Purpose
 

Verify that the Collector IUT can receive notifications of the Cycling Power Measurement Characteristic from a CP Sensor including reserved flags.

- Reference

[3] 4.5

- Initial Condition

- A preamble procedure defined in Section 4.2.4 if using an LE transport or 4.2.6 if using a BR/EDR transport is used to set up the transport and L2CAP channel and initiate connection to a CP Sensor.
- The IUT has executed the procedure included in [CPP/COL/CPF/BV-05-C \[Configure Cycling Power Measurement for Notification\]](#), which configures it to expect Cycling Power Measurement Notifications.
- The IUT knows the handle of the Cycling Power Measurement characteristic.

- Test Procedure

The Lower Tester sends an *ATT\_Handle\_Value\_Notification* containing a Cycling Power Measurement characteristic value to the IUT. There are many combinations of reserved flag settings. For this test use Flags = 0xE000. This includes reserved bits 15, 14, and 13 = 111. Optional fields are not present in the Cycling Power Measurement characteristic, so other bits of the Flags field are set to 0 as well as the Offset Compensation Indicator.

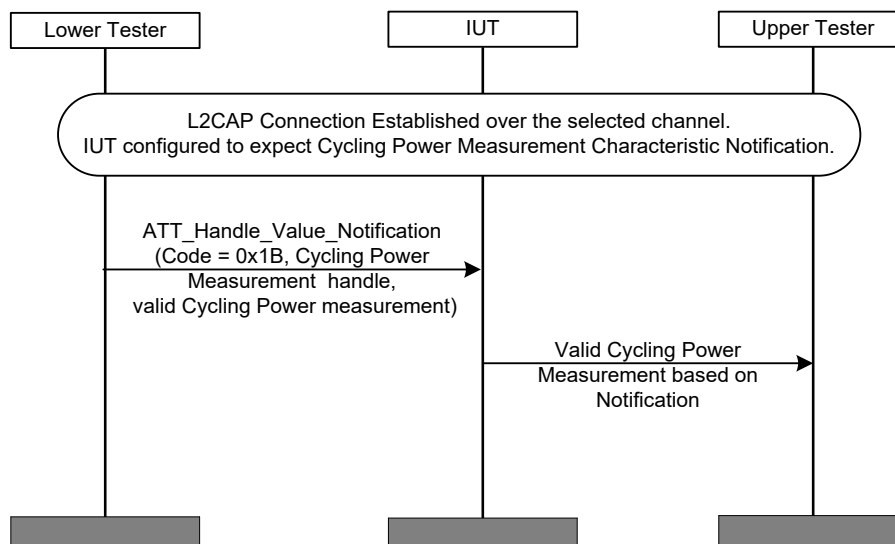

Figure 4.7: Receive Cycling Power Measurement Notifications with reserved flags MSC

- Expected Outcome

Pass verdict

The IUT reports the received Cycling Power Measurement value to the Upper Tester. The reported Cycling Power Measurement value matches the one sent by the Lower Tester, including the reserved bits of the Flags field.

### CPP/COL/CPF/BI-03-C [Receive Cycling Power Measurement Notifications with additional octets not represented in the flags field]

- Test Purpose

Verify that the Collector IUT can receive notifications of the Cycling Power Measurement Characteristic from a CP Sensor including additional octets not represented in the flags field.

- Reference

[3] 4.5

- Initial Condition

- A preamble procedure defined in Section 4.2.4 if using an LE transport or 4.2.6 if using a BR/EDR transport is used to set up the transport and L2CAP channel and initiate connection to a CP Sensor.
- The IUT has executed the procedure included in CPP/COL/CPF/BV-05-C [Configure Cycling Power Measurement for Notification], which configures it to expect Cycling Power Measurement Notifications.
- The IUT knows the handle of the Cycling Power Measurement characteristic.

- Test Procedure

The Lower Tester sends an *ATT\_Handle\_Value\_Notification* containing a Cycling Power Measurement characteristic value to the IUT. That value contains: Flags = 0x0000 and Instantaneous Power. The optional fields are not present, and, at least, two additional octets not represented in the flags field are present. The total number of octets does not exceed the maximum MTU size.

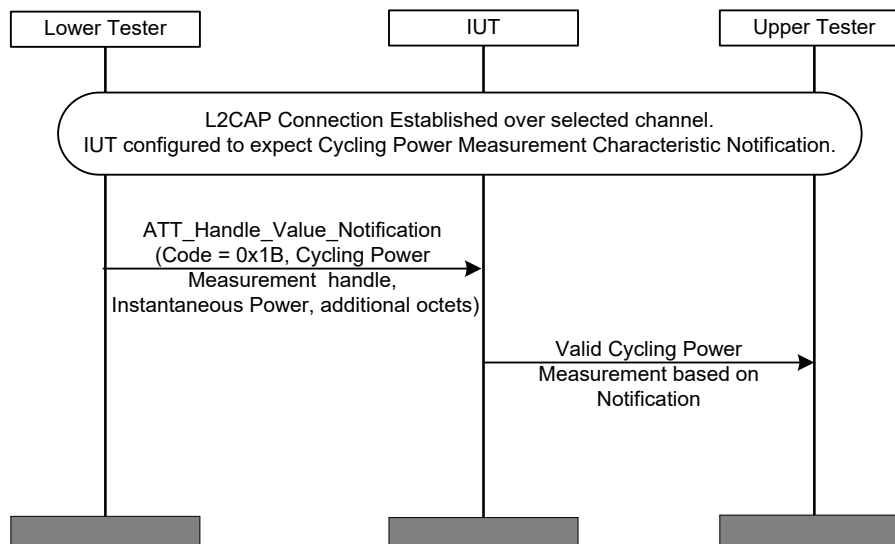

Figure 4.8: Receive Cycling Power Measurement Notifications with additional octets not represented in the flags field MSC

- Expected Outcome

Pass verdict

The IUT reports the received Cycling Power Measurement value to the Upper Tester with no additional octets. The reported Cycling Power Measurement value matches the one sent by the Lower Tester.

## CPP/COL/CPF/BV-17-C [Receive Cycling Power Measurement Notifications from a Distributed Power System – Calculates Total Instantaneous Power]

- Test Purpose

Verify that the collector IUT can receive multiple Cycling Power Measurement notifications from a distributed power system (e.g., 2 CP Sensors) and calculates the total instantaneous power based on each instantaneous power component.

- Reference

[3] 4.5

- Initial Condition

- A preamble procedure defined in Section 4.2.4 if using an LE transport or 4.2.6 if using a BR/EDR transport is used to set up the transport and L2CAP channel and initiate connection to a CP Sensor. This preamble is repeated to initiate a connection to both CP Sensors (Lower Tester) involved in this test case. The first Lower Tester is configured with a Sensor Location set to “Left Pedal” (0x07) and the second Lower Tester is configured with a Sensor Location set to “Right Pedal” (0x08).
- The IUT has executed the procedure included in CPP/COL/CPF/BV-05-C [Configure Cycling Power Measurement for Notification], which configures it to expect Cycling Power Measurement Notifications for both CP Sensors.
- The IUT knows the handle of the Cycling Power Measurement characteristic of both CP Sensors.

- Test Procedure

1. Perform an action on the Lower Tester that will induce setting the Instantaneous Power values in the table below.

	Instantaneous Power [W]		Expected Total Instantaneous Power [W]
	Lower Tester 1 (Left Pedal)	Lower Tester 2 (Right Pedal)	
1	200	220	Not checked by the Lower Tester
2	200	220	420
3	180	200	Not checked by the Lower Tester
4	180	200	380

Table 4.14: Receive Cycling Power Measurement Notifications from a Distributed Power System – Calculates Total Instantaneous Power

2. The Lower Testers send three *ATT\_Handle\_Value\_Notifications* containing a Cycling Power Measurement characteristic value to the IUT (corresponding to the sequence of rows in the table above) that simulate a regular and consistent power measurement as on a bike.
3. The IUT displays the value of the total instantaneous power value calculated by summing both values coming from the two different Lower Testers.

- Expected Outcome

Pass verdict

The IUT receives notifications of Cycling Power Measurement values from the Lower Testers that include the Flags field and, at least, the Instantaneous Power field.

The IUT correctly calculates consistent total instantaneous power.

### CPP/COL/CPF/BV-18-C [Receive Cycling Power Measurement Notifications from a Distributed Power System – Calculates Pedal Power Balance]

- Test Purpose

Verify that the collector IUT can receive multiple Cycling Power Measurement notifications from a distributed power system (e.g., 2 CP Sensors) and calculates the total instantaneous power based on each instantaneous power component.

- Reference

[3] 4.5

- Initial Condition

- A preamble procedure defined in Section 4.2.4 if using an LE transport or 4.2.6 if using a BR/EDR transport is used to set up the transport and L2CAP channel and initiate connection to a CP Sensor. This preamble is repeated to initiate a connection to both CP Sensors (Lower Tester) involved in this test case. The first Lower Tester is configured with a Sensor Location set to “Left Pedal” (0x07) and the second Lower Tester is configured with a Sensor Location set to “Right Pedal” (0x08).
- The IUT has executed the procedure included in CPP/COL/CPF/BV-05-C [Configure Cycling Power Measurement for Notification], which configures it to expect Cycling Power Measurement Notifications for both CP Sensors.
- The IUT knows the handle of the Cycling Power Measurement characteristic of both CP Sensors.

- Test Procedure

1. Perform an action on the Lower Tester that will induce setting the Instantaneous Power values in the table below.

	Instantaneous Power [W]		Expected Pedal Power Balance [%] (Left Pedal as the reference)
	Lower Tester 1 (Left Pedal)	Lower Tester 2 (Right Pedal)	
1	200	220	Not checked by the Lower Tester
2	200	220	47.6
3	180	220	Not checked by the Lower Tester
4	180	220	45.0

Table 4.15: Receive Cycling Power Measurement Notifications from a Distributed Power System – Calculates Pedal Power Balance

2. The Lower Testers send three *ATT\_Handle\_Value\_Notifications* containing a Cycling Power Measurement characteristic value to the IUT (corresponding to the sequence of rows in the table above) that simulate a regular and consistent power measurement as on a bike.
3. The IUT displays the value of the pedal power balance value calculated with the values coming from the two different Lower Testers.

- Expected Outcome

Pass verdict

The IUT receives notifications of Cycling Power Measurement values from the Lower Testers that include the Flags field and, at least, the Instantaneous Power field.

The IUT correctly calculates consistent pedal power balance.

### CPP/COL/CPF/BI-04-C [Read Sensor Location characteristic with reserved value]

- Test Purpose

Verify that the Collector IUT can read the Sensor Location characteristic from a CP Sensor, and discard a reserved value or change it to 'Other'.

- Reference

[3] 4.6

- Initial Condition

- A preamble procedure defined in Section 4.2.4 if using an LE transport or 4.2.6 if using a BR/EDR transport is used to set up the transport and L2CAP channel and initiate connection to a CP Sensor.
- The Upper Tester knows the handle of a Sensor Location characteristic contained in the Lower Tester.

- Test Procedure

1. Send a command from Upper Tester to request IUT to read a Sensor Location Characteristic from the Lower Tester, e.g., *CPP\_ReadReq* (handle, value).
2. After receipt of the expected result by the Lower Tester from the IUT, send an *ATT\_Read\_Response* (0x0B) from the Lower Tester to the IUT containing a reserved value.

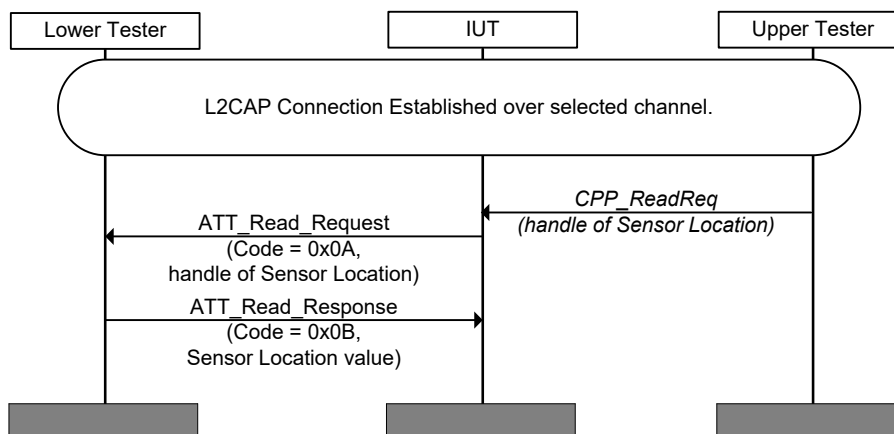

Figure 4.9: Read Sensor Location characteristic with reserved value MSC

- Expected Outcome

Pass verdict

The IUT sends a correctly formatted *ATT\_Read\_Request* (0x0A) to the Lower Tester, containing the handle specified by the Upper Tester.

The IUT receives the response from the Lower Tester and discards it or changes it to 'Other'.

## CPP/COL/CPF/BV-20-C [Configure Cycling Power Vector for Notification]

- Test Purpose
 

Verify that the Collector IUT can configure a CP Sensor (Lower Tester) to notify Cycling Power Vector characteristics.
- Reference
 

[3] 4.7 and 4.8
- Initial Condition
  - A preamble procedure defined in Section 4.2.4 if using an LE transport or 4.2.6 if using a BR/EDR transport is used to set up the transport and L2CAP channel and initiate connection to a CP Sensor.
  - The IUT has discovered the Client Characteristic Configuration Descriptor for a Cycling Power Vector characteristic contained in the Lower Tester.
  - Following the completion of the discovery procedures, the Lower Tester requests slow connection parameters (e.g., connection interval of one second using the GAP Connection Parameter Update procedure), and the IUT has updated the connection parameters as requested.
- Test Procedure
  1. The Upper Tester sends a command to the IUT to configure the CP Sensor to receive Cycling Power Vector characteristics.
  2. The IUT writes 0x0001 to the Client Characteristic Configuration descriptor of the Cycling Power Vector characteristic to enable the notification.
  3. The Lower Tester requests faster connection parameters in order to send the notification of the Cycling Power Vector characteristic (e.g., connection interval of 200 milliseconds using the GAP Connection Parameter Update procedure).
  4. The IUT accepts the request and updates the connection parameters as requested by the Lower Tester.
  5. The Lower Tester sends a Write Response to the IUT to acknowledge the write request sent in Step 2.

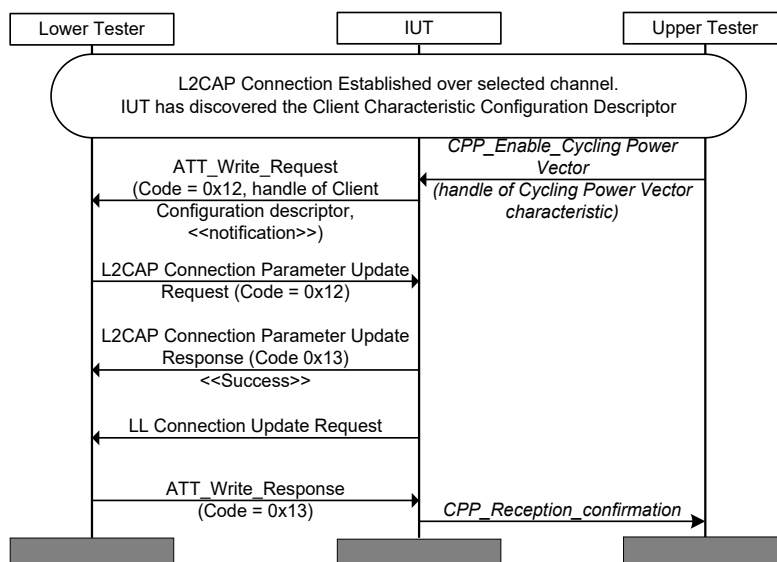

Figure 4.10: Configure Cycling Power Vector for Notification MSC

- Expected Outcome

Pass verdict

The IUT sends a correctly formatted *ATT\_Write\_Request* (0x12) to the Lower Tester, with the handle set to that of the Client Characteristic Configuration Descriptor for a Cycling Power Vector characteristic, and the value set to «notification».

The IUT accepts a request from the Lower Tester and updates the connection parameter as requested.

### CPP/COL/CPF/BV-21-C [Receive Cycling Power Vector Notifications]

- Test Purpose

Verify that the Collector IUT can receive notifications of the Cycling Power Vector Characteristic, including all variants.

- Reference

[3] 4.7 and 4.8

- Initial Condition

- A preamble procedure defined in Section 4.2.4 if using an LE transport or 4.2.6 if using a BR/EDR transport is used to set up the transport and L2CAP channel and initiate connection to a CP Sensor.
- The IUT has executed the procedure included in [CPP/COL/CPF/BV-20-C \[Configure Cycling Power Vector for Notification\]](#), which configures it to expect Cycling Power Vector Notifications.
- The IUT knows the handle of the Cycling Power Vector characteristic.

- Test Procedure

1. The Lower Tester sends an *ATT\_Handle\_Value\_Notification* containing a Cycling Power Vector characteristic value to the IUT.
2. The Lower Tester sends one Cycling Power Vector characteristic notification for each Test Pattern shown in the following table. For each Test Pattern, the value of the Flags field is shown along with the corresponding pass criteria.

Test Pattern	Sensor Measurement Context of the Cycling Power Feature characteristic	Flags Field Value	Pass Criteria
1	Force based (0)	00000100	Only optional field present is Instantaneous Force Magnitude Array.
2	Force based (0)	00000111	Only optional fields present are Cumulative Crank Revolutions, Last Crank Event Time, First Crank Measurement Angle and Instantaneous Force Magnitude Array.
3	Torque based (1)	00001000	Only optional field present is Instantaneous Torque Magnitude Array.

Test Pattern	Sensor Measurement Context of the Cycling Power Feature characteristic	Flags Field Value	Pass Criteria
4	Torque based (1)	00001011	Only optional fields present are Cumulative Crank Revolutions, Last Crank Event Time, First Crank Measurement Angle and Instantaneous Torque Magnitude Array.

Table 4.16: Receive Cycling Power Vector Notifications

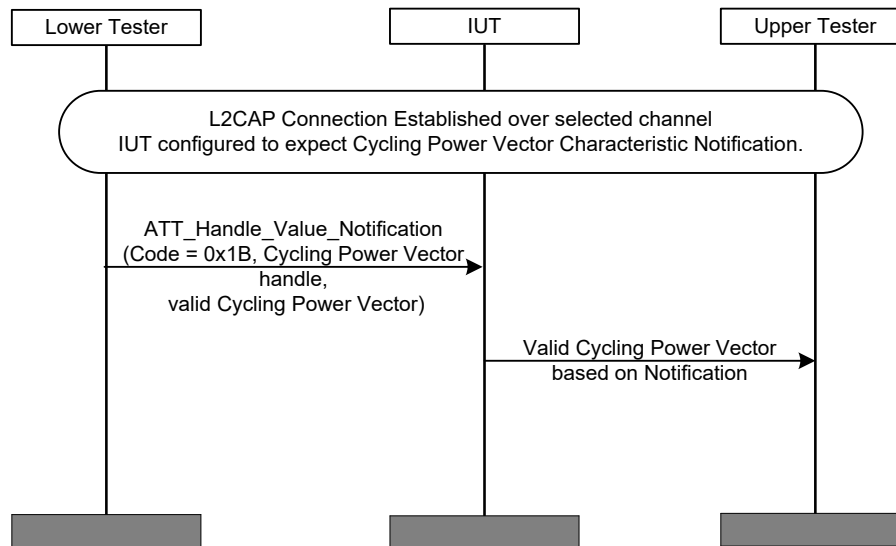

Figure 4.11: Receive Cycling Power Vector Notifications MSC

- Expected Outcome

#### Pass verdict

The IUT is able to correctly parse the received Cycling Power Vector values according to the pass criteria in the table above. The reported Cycling Power Measurement field values match the ones sent by the Lower Tester.

### CPP/COL/CPF/BV-22-C [Receive Cycling Power Vector Notifications – Cumulative Crank Revolutions Roll Over]

- Test Purpose

Verify that the Collector IUT can receive notifications of the Cycling Power Vector Characteristic and properly calculate cadence when the value of the Cumulative Crank Revolutions field rolls over.

- Reference

[3] 4.7 and 4.8

- Initial Condition
  - A preamble procedure defined in Section 4.2.4 if using an LE transport or 4.2.6 if using a BR/EDR transport is used to set up the transport and L2CAP channel and initiate connection to a CP Sensor.
  - The IUT has executed the procedure included in [CPP/COL/CPF/BV-20-C \[Configure Cycling Power Vector for Notification\]](#), which configures it to expect Cycling Power Vector Notifications.
  - The IUT knows the handle of the Cycling Power Vector characteristic.

- Test Procedure

Perform an action on the Lower Tester that will induce setting the Cumulative Crank Revolutions values and the Last Crank Event Time values in the table below such as to induce a Cumulative Crank Revolutions rollover event.

	Cumulative Crank Revolutions	Last Crank Event Time [1/1024s]	Expected Instantaneous Cadence [rpm]
1	65534	9300	N/A
2	65535	9982	90
3	1	11348	90
4	2	12030	90
5	4	13396	90

Table 4.17: Receive Cycling Power Vector Notifications – Cumulative Crank Revolutions Rollover

The Lower Tester sends five *ATT\_Handle\_Value\_Notifications* containing a Cycling Power Vector characteristic value to the IUT (corresponding to the sequence of rows in the table above) that simulate a regular and consistent crank rotation as on a bike including a Cumulative Crank Revolutions field rollover event.

The IUT responds correctly when the Cumulative Crank Revolutions value rolls over.

- Expected Outcome

Pass verdict

The IUT receives notifications of Cycling Power Vector values from the Lower Tester that include Crank Revolution Data.

The IUT correctly calculates consistent instantaneous cadence values before and after the rollover event.

### CPP/COL/CPF/BV-23-C [Receive Cycling Power Vector Notifications – Last Crank Event Time Roll Over]

- Test Purpose

Verify that the Collector IUT can receive notifications of the Cycling Power Vector Characteristic and properly calculate cadence when the value of the Last Crank Event Time field rolls over.

- Reference

[3] 4.7 and 4.8

- Initial Condition
  - A preamble procedure defined in Section 4.2.4 if using an LE transport or 4.2.6 if using a BR/EDR transport is used to set up the transport and L2CAP channel and initiate connection to a CP Sensor.
  - The IUT has executed the procedure included in [CPP/COL/CPF/BV-20-C \[Configure Cycling Power Vector for Notification\]](#), which configures it to expect Cycling Power Vector Notifications.
  - The IUT knows the handle of the Cycling Power Vector characteristic.

- Test Procedure

1. Perform an action on the Lower Tester that will induce setting the Cumulative Crank Revolutions values and the Last Crank Event Time values in the table below such as to induce a Last Crank Event Time rollover event.

	Cumulative Crank Revolutions	Last Crank Event Time [1/1024s]	Expected Instantaneous Cadence [rpm]
1	0	64000	N/A
2	1	64682	90
3	3	512	90
4	4	1194	90
5	6	2560	90

Table 4.18: Receive Cycling Power Vector Notifications – Last Crank Event Time Rollover

2. The Lower Tester sends five *ATT\_Handle\_Value\_Notifications* containing a Cycling Power Vector characteristic value to the IUT (corresponding to the sequence of rows in the table above) that simulate a regular and consistent crank rotation as on a bike including a Last Crank Event Time field rollover event.
3. The IUT responds correctly when the Last Crank Event Time value rolls over.

- Expected Outcome

Pass verdict

The IUT receives notifications of Cycling Power Vector values from the Lower Tester that include Crank Revolution Data.

The IUT correctly calculates consistent instantaneous cadence values before and after the rollover event.

### [CPP/COL/CPF/BI-05-C \[Receive Cycling Power Vector Notifications with reserved flags\]](#)

- Test Purpose

Verify that the Collector IUT can receive notifications of the Cycling Power Vector Characteristic from a CP Sensor including reserved flags.

- Reference

[3] 4.7 and 4.8

- Initial Condition
  - A preamble procedure defined in Section 4.2.4 if using an LE transport or 4.2.6 if using a BR/EDR transport is used to set up the transport and L2CAP channel and initiate connection to a CP Sensor.
  - The IUT has executed the procedure included in CPP/COL/CPF/BV-20-C [Configure Cycling Power Vector for Notification], which configures it to expect Cycling Power Vector Notifications.
  - The IUT knows the handle of the Cycling Power Vector characteristic.
- Test Procedure

The Lower Tester sends an *ATT\_Handle\_Value\_Notification* containing a Cycling Power Vector characteristic value to the IUT. There are many combinations of reserved flag settings. For this test use Flags = 0xC4. This includes reserved bits 7 and 6 = 11. Only optional fields present in the Cycling Power Vector characteristic is the Instantaneous Force Magnitude Array, so bit 2 of the Flags field is set to 1 and other bits are set to 0.

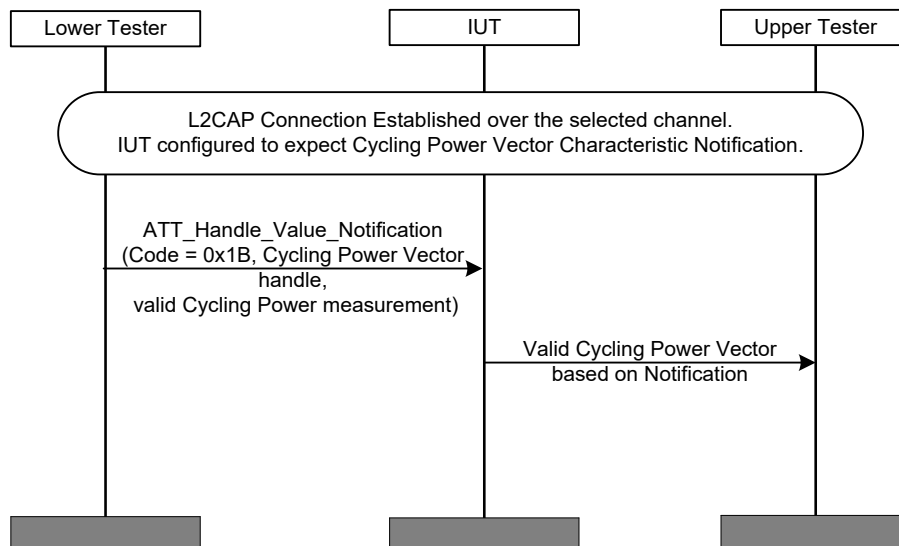

Figure 4.12: Receive Cycling Power Vector Notifications with reserved flags MSC

- Expected Outcome

#### Pass verdict

The IUT reports the received Cycling Power Vector value to the Upper Tester. The reported Cycling Power Measurement value matches the one sent by the Lower Tester, including the reserved bits of the Flags field.

### CPP/COL/CPF/BV-24-C [Lost Bond Procedure when using LE Transport]

- Test Purpose

Verify that the Collector IUT starts encryption with a bonded CP Sensor on reconnection and rediscovers and reconfigures CP Sensor if bond is lost.

- Reference

[3] 7.2.1

- Initial Condition
  - The IUT and the Lower Tester have previously bonded.
  - The IUT has configured the Lower Tester to enable notifications on the Cycling Power Measurement characteristic of the Lower Tester's Cycling Power Service.
  - The Lower Tester has the «Service Changed» characteristic.
  - No connection is established between the IUT and Lower Tester.
  - The bond is deleted at the Lower Tester.
- Test Procedure
  1. The Lower Tester begins advertising using GAP undirected connectable mode.
  2. The IUT establishes a connection to the Lower Tester.
  3. The Lower Tester does not send any notifications to IUT.
  4. The IUT starts encryption when the connection is established and rediscovers and reconfigures the CP Sensor upon detection of the lost bond.

- Expected Outcome

Pass verdict

The IUT starts encryption when the connection is established.

The IUT rediscovers the Cycling Power Service.

The IUT reconfigures the Client Characteristic Configuration descriptors of the Cycling Power Measurement characteristic, the Cycling Power Control Point characteristic and the Cycling Power Vector (if supported).

### CPP/COL/CPF/BV-25-C [Lost Bond Procedure when using BR/EDR transport]

- Test Purpose

Verify that the Collector IUT reconfigures the CP Sensor if the bond is lost.

In case of BR/EDR, either the Lower Tester or the Collector IUT could initiate a connection when they are bonded. The device initiating the connection becomes a Central and is referred to herein as a paging device, and the device accepting the connection becomes a Peripheral and is referred to herein as a page scanning device. Verify that the Central starts encryption with a bonded Peripheral on reconnection.

- Reference

[3] 7.3. 2

- Initial Condition

- The IUT and the Lower Tester have previously bonded.
- The IUT has configured the Lower Tester to enable notifications on the Cycling Power Measurement characteristic of the Lower Tester's Cycling Power Service.
- The Lower Tester has the «Service Changed» characteristic.
- No connection is established between the IUT and Lower Tester.
- The bond is deleted at the Lower Tester.

- Test Procedure
  1. The page scanning device is in connectable mode.
  2. The paging device establishes a connection to the page scanning device.
  3. The Lower Tester does not send any notifications to the IUT.
  4. The Central starts encryption when the connection is established.
  5. The IUT rediscovers and reconfigures the CP Sensor upon detection of the lost bond.

- Expected Outcome

Pass verdict

The paging device starts encryption when the connection is established.

The IUT rediscovers the Cycling Power Service.

The IUT reconfigures the Client Characteristic Configuration descriptors of the Cycling Power Measurement characteristic, the Cycling Power Control Point characteristic and the Cycling Power Vector (if supported).

### CPP/COL/CPF/BV-26-C [Configure Cycling Power Measurement for Broadcast]

- Test Purpose

Verify that the Collector IUT can configure a CP Sensor (Lower Tester) to broadcast Cycling Power Measurement characteristics (e.g., include the characteristic value in a undirected non-connectable advertisement).

- Reference

[3] 4.5.1

- Initial Condition

- A preamble procedure defined in Section 4.2.4 if using an LE transport or 4.2.6 if using a BR/EDR transport is used to set up the transport and L2CAP channel and initiate connection to a CP Sensor.
- The IUT has discovered the Server Characteristic Configuration Descriptor for a Cycling Power Measurement characteristic contained in the Lower Tester.

- Test Procedure

The Upper Tester sends a command to the IUT to configure the CP Sensor to broadcast the Cycling Power Measurement characteristics (e.g., include the characteristic value in an undirected non-connectable advertisement).

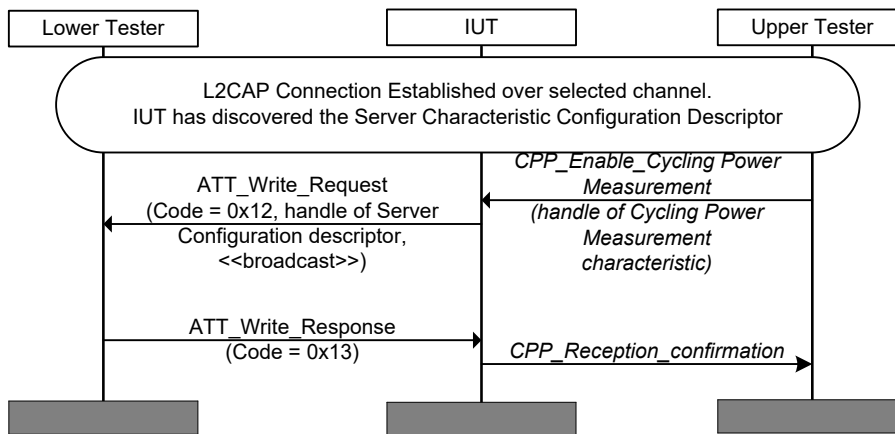

Figure 4.13: Configure Cycling Power Measurement for Broadcast MSC

- Expected Outcome

Pass verdict

The IUT sends a correctly formatted *ATT\_Write\_Request* (0x12) to the Lower Tester, with the handle set to that of the Server Characteristic Configuration Descriptor for a Cycling Power Measurement characteristic, and the value set to «broadcast».

### CPP/OBS/CPF/BV-27-C [Receive Cycling Power Measurement Broadcast]

- Test Purpose

Verify that the CP Observer IUT can receive undirected non-connectable advertisement with the Cycling Power Measurement Characteristic, including all variants.

- Reference

[3] 6.1

- Initial Condition

- Perform the preamble described in Section 4.2.5.
- The IUT knows the UUID of the Cycling Power Service.

- Test Procedure

The Lower Tester sends one or more undirected non-connectable advertisements including the Cycling Power Measurement characteristic value for each Test Pattern shown in the following table. For each Test Pattern, the value of the Flags field is shown along with the corresponding pass criteria.

Test Pattern	Flags Field Value (bit15 ... bit0)	Pass Criteria
1	00000000 – 00000001	Only optional field present is Pedal Power Balance with the Pedal Power Balance Reference set to “Unknown”.
2	00000000 – 00000011	Only optional field present is Pedal Power Balance with the Pedal Power Balance Reference set to “Left”.
3	00000000 – 00000100	Only optional field present is Accumulated Torque with the Accumulated Torque Source set to “Wheel based”.

Test Pattern	Flags Field Value (bit15 ... bit0)	Pass Criteria
4	00000000 – 00001100	Only optional field present is Accumulated Torque with the Accumulated Torque Source set to “Crank based”.
5	00000000 – 00010000	Only optional fields present are Cumulative Wheel Revolutions and Last Wheel Event Time.
6	00000000 – 00100000	Only optional fields present are Cumulative Crank Revolutions and Last Crank Event Time.
7	00000000 – 01000000	Only optional fields present are Maximum Force Magnitude and Minimum Force Magnitude.
8	00000000 – 10000000	Only optional fields present are Maximum Torque Magnitude and Minimum Torque Magnitude.
9	00000001 – 00000000	Only optional fields present are Maximum Angle and Minimum Angle.
10	00000010 – 00000000	Only optional field present is Top Dead Spot.
11	00000100 – 00000000	Only optional field present is Bottom Dead Spot.
12	00001000 – 00000000	Only optional field present is Accumulated Energy.
13	00010000 – 00000000	No optional field present. Offset Compensation Indicator set to True.

Table 4.19: Receive Cycling Power Measurement Broadcast

- Expected Outcome

Pass verdict

The IUT is able to correctly parse the received Cycling Power Measurement values according to the pass criteria in the table above. The reported Cycling Power Measurement field values match the ones sent by the Lower Tester.

### CPP/OBS/CPF/BV-28-C [Receive Cycling Power Measurement Broadcast – Accumulated Torque Roll Over]

- Test Purpose

Verify that the Collector IUT can receive undirected non-connectable advertisement with the Cycling Power Measurement characteristic and properly calculate accumulated torque when the value of the Accumulated Torque field rolls over.

- Reference

[3] 6.1

- Initial Condition

- Perform the preamble described in Section 4.2.5.
- The IUT knows the UUID of the Cycling Power Service.

- Test Procedure
  1. Perform an action on the Lower Tester that will induce setting the Accumulated Torque values in the table below such as to induce an Accumulated Torque rollover event.

	Accumulated Torque Value [1/32 Nm]	Expected Accumulated Torque at IUT [Nm]
1	64960 (0xFDC0)	2030.0
2	65280 (0xFF00)	2040.0
3	96 (0x0060)	2050.0
4	416 (0x01A0)	2060.0
5	736 (0x02E0)	2070.0

Table 4.20: Receive Cycling Power Measurement Broadcast – Accumulated Torque Rollover

2. The Lower Tester sends five undirected non-connectable advertisements containing a Cycling Power Measurement characteristic value to the IUT (corresponding to the sequence of rows in the table above) that simulate a regular and consistent torque accumulation as on a bike including an Accumulated Torque field rollover event.
  3. The IUT responds correctly when the Accumulated Torque value rolls over.
- Expected Outcome

Pass verdict

The IUT receives notifications of Cycling Power Measurement values from the Lower Tester that include Accumulated Torque field.

The IUT correctly calculates consistent accumulated torque values before and after the rollover event.

### CPP/OBS/CPF/BV-29-C [Receive Cycling Power Measurement Broadcast – Last Wheel Event Time Roll Over]

- Test Purpose
 

Verify that the Collector IUT can receive undirected non-connectable advertisement with the Cycling Power Measurement characteristic and properly calculate accumulated torque when the value of the Last Wheel Event Time field rolls over.
- Reference
 

[3] 6.1
- Initial Condition
  - Perform the preamble described in Section 4.2.5.
  - The IUT knows the UUID of the Cycling Power Service.

- Test Procedure
  1. Configure the IUT for Instantaneous Speed calculation with a wheel circumference of 210 centimeters. An IUT may be configured to an alternative value for calculation. Any alternative value is noted and included in testing evidence to support the calculated value of Instantaneous Speed.
  2. Perform an action on the Lower Tester that will induce setting the Cumulative Wheel Revolutions values and the Last Wheel Event Time values in the table below such as to induce a Last Wheel Event Time rollover event.

	Cumulative Wheel Revolution	Last Wheel Event Time [1/2048s]	Expected Instantaneous Speed at IUT [km/h]
1	1000	63000	N/A
2	1008	65048	60.48
3	1016	1560	60.48
4	1024	3608	60.48
5	1032	5656	60.48

Table 4.21: Receive Cycling Power Measurement Broadcast – Last Wheel Event Time Rollover

3. The Lower Tester sends five undirected non-connectable advertisements containing a Cycling Power Measurement characteristic value to the IUT (corresponding to the sequence of rows in the table above) that simulate a regular and consistent wheel rotation as on a bike including a Last Wheel Event Time field rollover event.
  4. The IUT responds correctly when the Last Wheel Event Time value rolls over.
- Expected Outcome

Pass verdict

The IUT receives notifications of Cycling Power Measurement values from the Lower Tester that include Wheel Revolution Data.

The IUT correctly calculates consistent instantaneous speed values before and after the rollover event.

### CPP/OBS/CPF/BV-30-C [Receive Cycling Power Measurement Broadcast – Cumulative Crank Revolutions Roll Over]

- Test Purpose
 

Verify that the Collector IUT can receive undirected non-connectable advertisement with the Cycling Power Measurement characteristic and properly calculate accumulated torque when the value of the Cumulative Crank Revolutions field rolls over.
- Reference
 

[3] 6.1
- Initial Condition
  - Perform the preamble described in Section 4.2.5.
  - The IUT knows the UUID of the Cycling Power Service.

- Test Procedure
  1. Perform an action on the Lower Tester that will induce setting the Cumulative Crank Revolutions values and the Last Crank Event Time values in the table below such as to induce a Cumulative Crank Revolutions rollover event.

	Cumulative Crank Revolutions	Last Crank Event Time [1/1024s]	Expected Instantaneous Cadence [rpm]
1	65470	9300	N/A
2	65530	9982	90
3	54	11348	90
4	114	12030	90
5	174	13396	90

Table 4.22: Receive Cycling Power Measurement Broadcast – Cumulative Crank Revolutions Rollover

2. The Lower Tester sends five undirected non-connectable advertisements containing a Cycling Power Measurement characteristic value to the IUT (corresponding to the sequence of rows in the table above) that simulate a regular and consistent crank rotation as on a bike including a Cumulative Crank Revolutions field rollover event.
  3. The IUT responds correctly when the Cumulative Crank Revolutions value rolls over.
- Expected Outcome

#### Pass verdict

The IUT receives notifications of Cycling Power Measurement values from the Lower Tester that include Crank Revolution Data.

The IUT correctly calculates consistent instantaneous cadence values before and after the rollover event.

### CPP/OBS/CPF/BV-31-C [Receive Cycling Power Measurement Broadcast – Last Crank Event Time Roll Over]

- Test Purpose
 

Verify that the Collector IUT can receive undirected non-connectable advertisement with the Cycling Power Measurement characteristic and properly calculate accumulated torque when the value of the Last Crank Event Time field rolls over.
- Reference
 

[3] 6.1
- Initial Condition
  - Perform the preamble described in Section 4.2.5.
  - The IUT knows the UUID of the Cycling Power Service.

- Test Procedure
  1. Perform an action on the Lower Tester that will induce setting the Cumulative Crank Revolutions values and the Last Crank Event Time values in the table below such as to induce a Last Crank Event Time rollover event.

	Cumulative Crank Revolutions	Last Crank Event Time [1/1024s]	Expected Instantaneous Cadence [rpm]
<b>1</b>	0	64000	N/A
<b>2</b>	1	64682	90
<b>3</b>	3	512	90
<b>4</b>	4	1194	90
<b>5</b>	6	2560	90

Table 4.23: Receive Cycling Power Measurement Broadcast – Last Crank Event Time Rollover

2. The Lower Tester sends five undirected non-connectable advertisements containing a Cycling Power Measurement characteristic value to the IUT (corresponding to the sequence of rows in the table above) that simulate a regular and consistent crank rotation as on a bike including a Last Crank Event Time field rollover event.
  3. The IUT responds correctly when the Last Crank Event Time value rolls over.
- Expected Outcome

Pass verdict

The IUT receives notifications of Cycling Power Measurement values from the Lower Tester that include Crank Revolution Data.

The IUT correctly calculates consistent instantaneous cadence values before and after the rollover event.

### CPP/OBS/CPF/BV-32-C [Receive Cycling Power Measurement Broadcast – Accumulated Energy Roll Over]

- Test Purpose
 

Verify that the Collector IUT can receive five undirected non-connectable advertisements of the Cycling Power Measurement Characteristic and properly calculate accumulated energy when the value of the Accumulated Energy field rolls over.
- Reference
 

[3] 6.1
- Initial Condition
  - Perform the preamble described in Section 4.2.5.
  - The IUT knows the UUID of the Cycling Power Service.

- Test Procedure
  1. Perform an action on the Lower Tester that will induce setting the Accumulated Energy values in the table below such as to induce an Accumulated Energy rollover event.

	Accumulated Energy Value [kJ]	Expected Accumulated Energy at IUT [kJ]
1	65532	65532
2	65534	65534
3	1	65536
4	3	65538
5	5	65540

Table 4.24: Receive Cycling Power Measurement Broadcast – Accumulated Energy Rollover

2. The Lower Tester sends five undirected non-connectable advertisements containing a Cycling Power Measurement characteristic value to the IUT (corresponding to the sequence of rows in the table above) that simulate a regular and consistent energy accumulation as on a bike including an Accumulated Energy field rollover event.
  3. The IUT responds correctly when the Accumulated Energy value rolls over.
- Expected Outcome

Pass verdict

The IUT receives notifications of Cycling Power Measurement values from the Lower Tester that include Accumulated Energy field.

The IUT correctly calculates consistent accumulated energy values before and after the rollover event.

### CPP/OBS/CPF/BI-06-C [Receive Cycling Power Measurement Broadcast with reserved flags]

- Test Purpose
 

Verify that the CP Observer IUT can receive undirected non-connectable advertisement with the Cycling Power Measurement Characteristic, including reserved flags.
- Reference
 

[3] 6.1
- Initial Condition
  - Perform the preamble described in Section 4.2.5.
  - The IUT knows the UUID of the Cycling Power Service.
- Test Procedure
 

The Lower Tester sends one or more undirected non-connectable advertisements including the Cycling Power Measurement characteristic value to the IUT. There are many combinations of reserved flag settings. For this test use Flags = 0xE000. This includes reserved bits 15, 14, and 13 = 111. Optional fields are not present in the Cycling Power Measurement characteristic, so other bits of the Flags field are set to 0 as well as the Offset Compensation Indicator.

- Expected Outcome

Pass verdict

The IUT is able to correctly parse the received Cycling Power Measurement values according to the pass criteria in the table above. The reported Cycling Power Measurement field values match the ones sent by the Lower Tester, including the reserved bits of the Flags field.

### CPP/OBS/CPF/BI-07-C [Receive Cycling Power Measurement Broadcast with additional octets not represented in the flags field]

- Test Purpose

Verify that the CP Observer IUT can receive undirected non-connectable advertisement with the Cycling Power Measurement Characteristic, including additional octets not represented in the flags field.

- Reference

[3] 6.1

- Initial Condition

- Perform the preamble described in Section 4.2.5.
- The IUT knows the UUID of the Cycling Power Service.

- Test Procedure

The Lower Tester sends one or more undirected non-connectable advertisements including the Cycling Power Measurement characteristic value to the IUT. That value contains: Flags = 0x00 and Instantaneous Power. The optional fields are not present, and, at least, two additional octets not represented in the flags field are present. The total number of octets does not exceed the maximum size allowed in an advertisement event.

- Expected Outcome

Pass verdict

The IUT reports the received Cycling Power Measurement value to the Upper Tester with no additional octets. The reported Cycling Power Measurement value matches the one sent by the Lower Tester.

### CPP/OBS/CPF/BV-33-C [Receive Cycling Power Measurement Broadcast from a Distributed Power System]

- Test Purpose

Verify that the collector IUT can receive multiple Cycling Power Measurement broadcast from a distributed power system (e.g., 2 CP Sensors).

- Reference

[3] 6.1

- Initial Condition
  - A preamble procedure defined in Section 4.2.5 is used to set up the IUT to receive the broadcast from the Lower Tester 1 including the Cycling Power Measurement characteristic. This preamble is repeated to set up the IUT to receive the broadcast from the Lower Tester 1 including the Cycling Power Measurement characteristic. The Lower Tester 1 simulates a CP Sensor located on the left pedal and the Lower Tester 2 simulates a CP Sensor located on the right pedal.
  - The IUT knows the UUID of the Cycling Power Service.
  - The IUT knows which Lower Tester corresponds to which measured data (e.g., left or right).
- Test Procedure
  1. The Lower Testers send one or more undirected non-connectable advertisements the Cycling Power Measurement characteristic value with at least the mandatory fields (e.g., the Flags field and the Instantaneous Power).
  2. The IUT displays the values of the Instantaneous Power for each CP Sensor and decodes properly the other optional fields, if present.

- Expected Outcome

Pass verdict

For each undirected non-connectable advertisement sent to the IUT:

- The IUT reports the received Cycling Power Measurement values to the Upper Tester.
- The reported Cycling Power Measurement values match that sent by the Lower Tester.

### CPP/OBS/CPF/BV-34-C [Receive Cycling Power Measurement Broadcast from a Distributed Power System – Calculates Total Instantaneous Power]

- Test Purpose

Verify that the collector IUT can receive multiple Cycling Power Measurement broadcast from a distributed power system (e.g., 2 CP Sensors) and calculates the total instantaneous power based on each instantaneous power component.

- Reference

[3] 6.1

- Initial Condition

- A preamble procedure defined in Section 4.2.5 is used to set up the IUT to receive broadcast from the Lower Tester 1 including the Cycling Power Measurement characteristic. This preamble is repeated to set up the IUT to receive broadcast from the Lower Tester 1 including the Cycling Power Measurement characteristic. The Lower Tester 1 simulates a CP Sensor located on the left pedal and the Lower Tester 2 simulates a CP Sensor located on the right pedal.
- The IUT knows the UUID of the Cycling Power Service.
- The IUT knows which Lower Tester corresponds to which sensor (e.g., left or right).

- Test Procedure
  1. Perform an action on the Lower Testers that will induce setting the Instantaneous Power values in the table below.

	Instantaneous Power [W]		Expected Total Instantaneous Power [W]
	Lower Tester 1 (Left Pedal)	Lower Tester 2 (Right Pedal)	
<b>1</b>	200	220	420
<b>2</b>	200	220	420
<b>3</b>	200	220	420

Table 4.25: Receive Cycling Power Measurement Broadcast from a Distributed Power System – Calculates Total Instantaneous Power

2. The Lower Testers send three undirected non-connectable advertisements containing a Cycling Power Measurement characteristic value to the IUT (corresponding to the sequence of rows in the table above) that simulate a regular and consistent power measurement as on a bike.
  3. The IUT displays the value of the total instantaneous power value calculated by summing both values coming from the two different Lower Testers.
- Expected Outcome

#### Pass verdict

The IUT receives undirected non-connectable advertisements containing Cycling Power Measurement values from the Lower Testers that include the Flags field and, at least, the Instantaneous Power field.

The IUT correctly calculates consistent total instantaneous power.

### CPP/OBS/CPF/BV-35-C [Receive Cycling Power Measurement Broadcast from a Distributed Power System – Calculates Pedal Power Balance]

- Test Purpose
 

Verify that the collector IUT can receive multiple Cycling Power Measurement broadcast from a distributed power system (e.g., 2 CP Sensors) and calculates the pedal power balance based on each instantaneous power component.
- Reference
 

[3] 6.1
- Initial Condition
  - A preamble procedure defined in Section 4.2.5 is used to set up the IUT to receive broadcast from the Lower Tester 1 including the Cycling Power Measurement characteristic. This preamble is repeated to set up the IUT to receive broadcast from the Lower Tester 1 including the Cycling Power Measurement characteristic. The Lower Tester 1 simulates a CP Sensor located on the left pedal and the Lower Tester 2 simulates a CP Sensor located on the right pedal.
  - The IUT knows the UUID of the Cycling Power Service.
  - The IUT knows which Lower Tester corresponds to which sensor (e.g., left or right).

- Test Procedure
  1. Perform an action on the Lower Testers that will induce setting the Instantaneous Power values in the table below.

	Instantaneous Power [W]		Expected Pedal Power Balance [%] (Left Pedal as the reference)
	Lower Tester 1 (Left Pedal)	Lower Tester 2 (Right Pedal)	
1	200	220	47.6
2	200	220	47.6
3	200	220	47.6

Table 4.26: Receive Cycling Power Measurement Broadcast from a Distributed Power System – Calculates Pedal Power Balance

2. The Lower Testers send three undirected non-connectable advertisements containing a Cycling Power Measurement characteristic value to the IUT (corresponding to the sequence of rows in the table above) that simulate a regular and consistent power measurement as on a bike.
  3. The IUT displays the value of the pedal power balance value calculated with the values coming from the two different Lower Testers.
- Expected Outcome

#### Pass verdict

The IUT receives undirected non-connectable advertisements containing Cycling Power Measurement values from the Lower Testers that include the Flags field and, at least, the Instantaneous Power field.

The IUT correctly calculates consistent pedal power balance.

### CPP/COL/CPF/BV-36-C [Receive Cycling Power Measurement Notifications from a Legacy CP Sensor]

- Test Purpose
 

Verify that the Collector IUT can receive notifications of the Cycling Power Measurement Characteristic, including all variants.
- Reference
 

[3] 4.5
- Initial Condition
  - A preamble procedure defined in Section 4.2.4 if using an LE transport or 4.2.6 if using a BR/EDR transport is used to set up the transport and L2CAP channel and initiate connection to a CP Sensor.
  - The Lower Tester has the Distributed System Support bits of the Cycling Power Feature characteristic set to “Unspecified” (0b00).
  - The IUT has read the Cycling Power Feature characteristic.
  - The IUT has executed the procedure included in CPP/COL/CPF/BV-05-C [Configure Cycling Power Measurement for Notification], which configures it to expect Cycling Power Measurement Notifications.
  - The IUT knows the handle of the Cycling Power Measurement characteristic.



- Test Procedure
  1. The Lower Tester sends an *ATT\_Handle\_Value\_Notification* containing a Cycling Power Measurement characteristic value to the IUT.
  2. The Lower Tester sends one Cycling Power Measurement characteristic notification for each Test Pattern shown in the following table. For each Test Pattern, the value of the Flags field is shown along with the corresponding pass criteria.

Test Pattern	Flags Field Value (bit15 ... bit0)	Pass Criteria
1	00000000 – 00000001	Only optional field present is Pedal Power Balance with the Pedal Power Balance Reference set to “Unknown”.
2	00000000 – 00000011	Only optional field present is Pedal Power Balance with the Pedal Power Balance Reference set to “Left”.
3	00000000 – 00000100	Only optional field present is Accumulated Torque with the Accumulated Torque Source set to “Wheel based”.
4	00000000 – 00001100	Only optional field present is Accumulated Torque with the Accumulated Torque Source set to “Crank based”.
5	00000000 – 00010000	Only optional fields present are Cumulative Wheel Revolutions and Last Wheel Event Time.
6	00000000 – 00100000	Only optional fields present are Cumulative Crank Revolutions and Last Crank Event Time.
7	00000000 – 01000000	Only optional fields present are Maximum Force Magnitude and Minimum Force Magnitude.
8	00000000 – 10000000	Only optional fields present are Maximum Torque Magnitude and Minimum Torque Magnitude.
9	00000001 – 00000000	Only optional fields present are Maximum Angle and Minimum Angle.
10	00000010 – 00000000	Only optional field present is Top Dead Spot.
11	00000100 – 00000000	Only optional field present is Bottom Dead Spot.
12	00001000 – 00000000	Only optional field present is Accumulated Energy.
13	00010000 – 00000000	No optional field present. Offset Compensation Indicator set to True.

Table 4.27: Receive Cycling Power Measurement Notifications from a Legacy CP Sensor

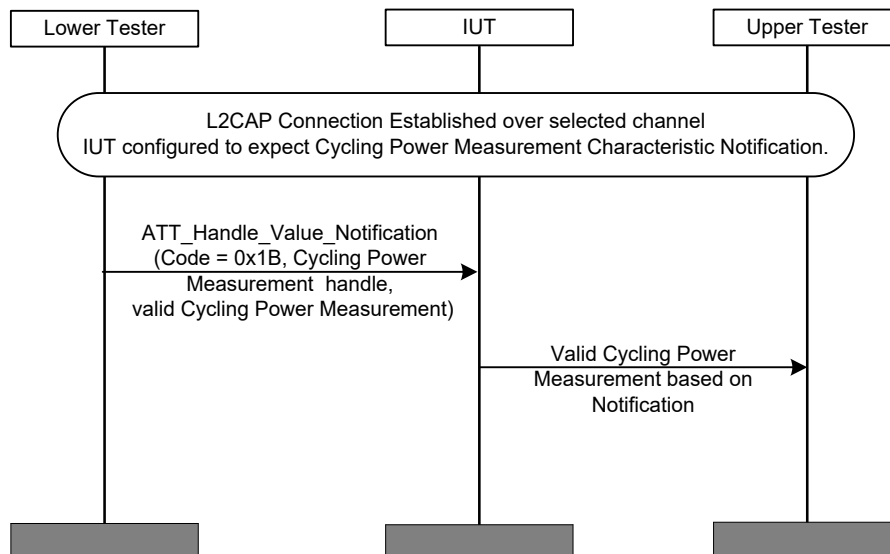

Figure 4.14: Receive Cycling Power Measurement Notifications from a Legacy CP Sensor MSC

- Expected Outcome

Pass verdict

The IUT is able to correctly parse the received Cycling Power Measurement values according to the pass criteria in the table above. The reported Cycling Power Measurement field values match the ones sent by the Lower Tester.

### CPP/COL/CPF/BV-37-C [Receive Cycling Power Measurement Notifications from a CP Sensor – Not For Use In A Distributed Power System]

- Test Purpose

Verify that the Collector IUT can receive notifications of the Cycling Power Measurement Characteristic, including all variants.

- Reference

[3] 4.5

- Initial Condition

- A preamble procedure defined in Section 4.2.4 if using an LE transport or 4.2.6 if using a BR/EDR transport is used to set up the transport and L2CAP channel and initiate connection to a CP Sensor.
- The Lower Tester has the Distributed System Support bits of the Cycling Power Feature characteristic set to “Not For Use In A Distributed Power System” (0b01).
- The IUT has read the Cycling Power Feature characteristic.
- The IUT has executed the procedure included in CPP/COL/CPF/BV-05-C [Configure Cycling Power Measurement for Notification], which configures it to expect Cycling Power Measurement Notifications.
- The IUT knows the handle of the Cycling Power Measurement characteristic.

- Test Procedure
  1. The Lower Tester sends an *ATT\_Handle\_Value\_Notification* containing a Cycling Power Measurement characteristic value to the IUT.
  2. The Lower Tester sends one Cycling Power Measurement characteristic notification for each Test Pattern shown in the following table. For each Test Pattern, the value of the Flags field is shown along with the corresponding pass criteria. The value of the Instantaneous Power value is set to 150 Watts.

Test Pattern	Flags Field Value (bit15 ... bit0)	Pass Criteria
1	00000000 – 00000001	Only optional field present is Pedal Power Balance with the Pedal Power Balance Reference set to “Unknown”.
2	00000000 – 00000011	Only optional field present is Pedal Power Balance with the Pedal Power Balance Reference set to “Left”.
3	00000000 – 00000100	Only optional field present is Accumulated Torque with the Accumulated Torque Source set to “Wheel based”.
4	00000000 – 00001100	Only optional field present is Accumulated Torque with the Accumulated Torque Source set to “Crank based”.
5	00000000 – 00010000	Only optional fields present are Cumulative Wheel Revolutions and Last Wheel Event Time.
6	00000000 – 00100000	Only optional fields present are Cumulative Crank Revolutions and Last Crank Event Time.
7	00000000 – 01000000	Only optional fields present are Maximum Force Magnitude and Minimum Force Magnitude.
8	00000000 – 10000000	Only optional fields present are Maximum Torque Magnitude and Minimum Torque Magnitude.
9	00000001 – 00000000	Only optional fields present are Maximum Angle and Minimum Angle.
10	00000010 – 00000000	Only optional field present is Top Dead Spot.
11	00000100 – 00000000	Only optional field present is Bottom Dead Spot.
12	00001000 – 00000000	Only optional field present is Accumulated Energy.
13	00010000 – 00000000	No optional field present. Offset Compensation Indicator set to True.

Table 4.28: Receive Cycling Power Measurement Notifications from a CP Sensor – Not For Use In A Distributed Power System

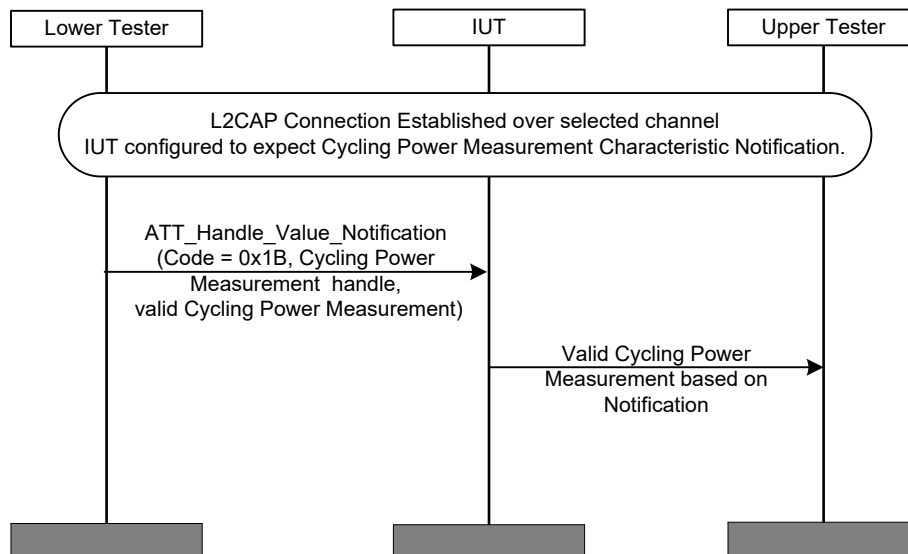

Figure 4.15: Receive Cycling Power Measurement Notifications from a CP Sensor – Not For Use In A Distributed Power System MSC

- Expected Outcome

Pass verdict

The IUT is able to correctly parse the received Cycling Power Measurement values according to the pass criteria in the table above. The reported Cycling Power Measurement field values match the ones sent by the Lower Tester and the Instantaneous Power value is equal to 150 Watts.

### CPP/COL/CPF/BV-38-C [Receive Cycling Power Measurement Notifications from a CP Sensor – Can Be Used In A Distributed Power System]

- Test Purpose

Verify that the Collector IUT can receive notifications of the Cycling Power Measurement Characteristic, including all variants.

- Reference

[3] 4.5

- Initial Condition

- A preamble procedure defined in Section 4.2.4 if using an LE transport or 4.2.6 if using a BR/EDR transport is used to set up the transport and L2CAP channel and initiate connection to a CP Sensor. The Lower Tester is configured with a Sensor Location set to “Left Pedal” (0x07).
- The Lower Tester has the Distributed System Support bits of the Cycling Power Feature characteristic set to “Can be used in a distributed power system” (0b10).
- The IUT has read the Cycling Power Feature characteristic.
- The IUT has executed the procedure included in CPP/COL/CPF/BV-05-C [Configure Cycling Power Measurement for Notification], which configures it to expect Cycling Power Measurement Notifications.
- The IUT knows the handle of the Cycling Power Measurement characteristic.

- Test Procedure
  1. The Lower Tester sends an *ATT\_Handle\_Value\_Notification* containing a Cycling Power Measurement characteristic value to the IUT.
  2. The Lower Tester sends one Cycling Power Measurement characteristic notification for each Test Pattern shown in the following table. For each Test Pattern, the value of the Flags field is shown along with the corresponding pass criteria. The value of the Instantaneous Power value sent by the Lower Tester 1 is set to 75 Watts.

Test Pattern	Flags Field Value (bit15 ... bit0)	Pass Criteria
1	00000000 – 00000001	Only optional field present is Pedal Power Balance with the Pedal Power Balance Reference set to “Unknown”.
2	00000000 – 00000011	Only optional field present is Pedal Power Balance with the Pedal Power Balance Reference set to “Left”.
3	00000000 – 00000100	Only optional field present is Accumulated Torque with the Accumulated Torque Source set to “Wheel based”.
4	00000000 – 00001100	Only optional field present is Accumulated Torque with the Accumulated Torque Source set to “Crank based”.
5	00000000 – 00010000	Only optional fields present are Cumulative Wheel Revolutions and Last Wheel Event Time.
6	00000000 – 00100000	Only optional fields present are Cumulative Crank Revolutions and Last Crank Event Time.
7	00000000 – 01000000	Only optional fields present are Maximum Force Magnitude and Minimum Force Magnitude.
8	00000000 – 10000000	Only optional fields present are Maximum Torque Magnitude and Minimum Torque Magnitude.
9	00000001 – 00000000	Only optional fields present are Maximum Angle and Minimum Angle.
10	00000010 – 00000000	Only optional field present is Top Dead Spot.
11	00000100 – 00000000	Only optional field present is Bottom Dead Spot.
12	00001000 – 00000000	Only optional field present is Accumulated Energy.
13	00010000 – 00000000	No optional field present. Offset Compensation Indicator set to True.

Table 4.29: Receive Cycling Power Measurement Notifications from a CP Sensor – Can Be Used In A Distributed Power System

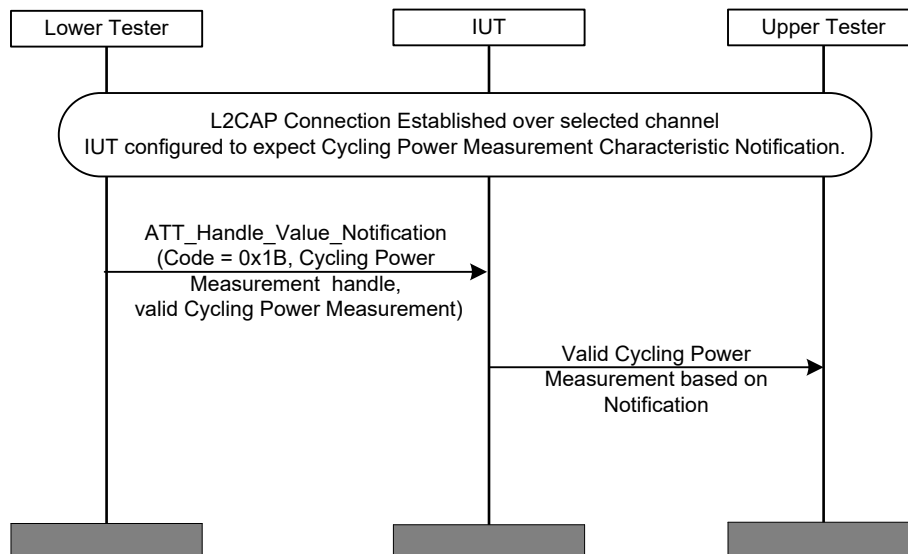

Figure 4.16: Receive Cycling Power Measurement Notifications from a CP Sensor – Can Be Used In A Distributed Power System MSC

- Expected Outcome

Pass verdict

The IUT is able to correctly parse the received Cycling Power Measurement values according to the pass criteria in the table above. The reported Cycling Power Measurement field values match the ones sent by the Lower Tester except the Instantaneous Power value that may be multiplied by two by the IUT (i.e., 150 Watts).

- Notes

The Instantaneous Power value reported by the IUT may be multiplied by two as explained in [3] 4.4.

### CPP/COL/CPF/BV-39-C [Receive Cycling Power Measurement Notifications from two CP Sensors – Can Be Used In A Distributed Power System – Total Instantaneous Power]

- Test Purpose

Verify that the collector IUT can receive multiple Cycling Power Measurement notifications from a distributed power system (e.g., two CP Sensors) and calculates the total instantaneous power based on each instantaneous power component.

- Reference

[3] 4.5

- Initial Condition

- A preamble procedure defined in Section 4.2.4 if using an LE transport or 4.2.6 if using a BR/EDR transport is used to set up the transport and L2CAP channel and initiate connection to a CP Sensor. This preamble is repeated to initiate a connection to both CP Sensors (Lower Tester) involved in this test case. The first Lower Tester is configured with a Sensor Location set to “Left Pedal” (0x07) and the second Lower Tester is configured with a Sensor Location set to “Right Pedal” (0x08).
- Both Lower Testers have the Distributed System Support bits of the Cycling Power Feature characteristic set to “Can be used in a distributed system” (0b10).

- The IUT has read the Cycling Power Feature characteristic.
  - The IUT has executed the procedure included in [CPP/COL/CPF/BV-05-C \[Configure Cycling Power Measurement for Notification\]](#), which configures it to expect Cycling Power Measurement Notifications for both CP Sensors.
  - The IUT knows the handle of the Cycling Power Measurement characteristic of both CP Sensors.
- Test Procedure
    1. Perform an action on the Lower Tester that will induce setting the Instantaneous Power values in the table below.

	Instantaneous Power [W]		Expected Total Instantaneous Power [W]
	Lower Tester 1 (Left Pedal)	Lower Tester 2 (Right Pedal)	
1	200	220	Not checked by the Lower Tester
2	200	220	420
3	180	200	Not checked by the Lower Tester
4	180	200	380

*Table 4.30: Receive Cycling Power Measurement Notifications from two CP Sensors – Can Be Used In A Distributed Power System – Total Instantaneous Power*

2. The Lower Testers send three *ATT\_Handle\_Value\_Notifications* containing a Cycling Power Measurement characteristic value to the IUT (corresponding to the sequence of rows in the table above) that simulate a regular and consistent power measurement as on a bike.
  3. The IUT displays the value of the total instantaneous power value calculated by summing both values coming from the two different Lower Testers (e.g., 420 Watts).
- Expected Outcome

Pass verdict

The IUT receives notifications of Cycling Power Measurement values from the Lower Testers that include the Flags field and, at least, the Instantaneous Power field.

The IUT correctly calculates consistent total instantaneous power.

### **CPP/COL/CPF/BV-40-C [Receive Cycling Power Measurement Notifications from two CP Sensors – Can Be Used in A Distributed Power System – Pedal Power Balance]**

- Test Purpose
 

Verify that the collector IUT can receive multiple Cycling Power Measurement notifications from a distributed power system (e.g., two CP Sensors) and calculates the total instantaneous power based on each instantaneous power component.
- Reference
 

[3] 4.5

- Initial Condition
  - A preamble procedure defined in Section 4.2.4 if using an LE transport or 4.2.6 if using a BR/EDR transport is used to set up the transport and L2CAP channel and initiate connection to a CP Sensor. This preamble is repeated to initiate a connection to both CP Sensors (Lower Tester) involved in this test case. The first Lower Tester is configured with a Sensor Location set to “Left Pedal” (0x07) and the second Lower Tester is configured with a Sensor Location set to “Right Pedal” (0x08).
  - Both Lower Testers have the Distributed System Support bits of the Cycling Power Feature characteristic set to “Can be used in a distributed system” (0b10).
  - The IUT has read the Cycling Power Feature characteristic.
  - The IUT has executed the procedure included in [CPP/COL/CPF/BV-05-C \[Configure Cycling Power Measurement for Notification\]](#), which configures it to expect Cycling Power Measurement Notifications for both CP Sensors.
  - The IUT knows the handle of the Cycling Power Measurement characteristic of both CP Sensors.
- Test Procedure
  1. Perform an action on the Lower Tester that will induce setting the Instantaneous Power values in the table below.

	Instantaneous Power [W]		Expected Pedal Power Balance [%] (Left Pedal as the reference)
	Lower Tester 1 (Left Pedal)	Lower Tester 2 (Right Pedal)	
1	200	220	Not checked by the Lower Tester
2	200	220	47.6
3	180	220	Not checked by the Lower Tester
4	180	220	45.0

Table 4.31: Receive Cycling Power Measurement Notifications from two CP Sensors – Can Be Used in A Distributed Power System – Pedal Power Balance

2. The Lower Testers send three *ATT\_Handle\_Value\_Notifications* containing a Cycling Power Measurement characteristic value to the IUT (corresponding to the sequence of rows in the table above) that simulate a regular and consistent power measurement as on a bike.
  3. The IUT displays the value of the pedal power balance value calculated with the values coming from the two different Lower Testers.
- Expected Outcome

#### Pass verdict

The IUT receives notifications of Cycling Power Measurement values from the Lower Testers that include the Flags field and, at least, the Instantaneous Power field.

The IUT correctly calculates consistent pedal power balance.

### [CPP/COL/CPF/BV-41-C \[Receive Cycling Power Measurement Notifications from two Legacy CP Sensors\]](#)

- Test Purpose
 

Verify that the Collector IUT can receive notifications of the Cycling Power Measurement Characteristic, including all variants.



- Reference
  - [3] 4.5
- Initial Condition
  - A preamble procedure defined in Section 4.2.4 if using an LE transport or 4.2.6 if using a BR/EDR transport is used to set up the transport and L2CAP channel and initiate connection to a CP Sensor. This preamble is repeated to initiate a connection to both CP Sensors (Lower Tester) involved in this test case. The first Lower Tester is configured with a Sensor Location set to “Left Pedal” (0x07) and the second Lower Tester is configured with a Sensor Location set to “Right Pedal” (0x08).
  - Both Lower Testers have the Distributed System Support bits of the Cycling Power Feature characteristic set to “Undefined” (0b00).
  - The IUT has read the Cycling Power Feature characteristic.
  - The IUT has executed the procedure included in CPP/COL/CPF/BV-05-C [Configure Cycling Power Measurement for Notification], which configures it to expect Cycling Power Measurement Notifications for both CP Sensors.
  - The IUT knows the handle of the Cycling Power Measurement characteristic of both CP Sensors.
- Test Procedure
  1. The Lower Testers send each an *ATT\_Handle\_Value\_Notification* containing a Cycling Power Measurement characteristic value to the IUT.
  2. The Lower Testers send one Cycling Power Measurement characteristic notification for each Test Pattern shown in the following table. For each Test Pattern, the value of the Flags field is shown along with the corresponding pass criteria.

Test Pattern	Flags Field Value (bit15 ... bit0)	Pass Criteria
1	00000000 – 00000001	Only optional field present is Pedal Power Balance with the Pedal Power Balance Reference set to “Unknown”.
2	00000000 – 00000011	Only optional field present is Pedal Power Balance with the Pedal Power Balance Reference set to “Left”.
3	00000000 – 00000100	Only optional field present is Accumulated Torque with the Accumulated Torque Source set to “Wheel based”.
4	00000000 – 00001100	Only optional field present is Accumulated Torque with the Accumulated Torque Source set to “Crank based”.
5	00000000 – 00010000	Only optional fields present are Cumulative Wheel Revolutions and Last Wheel Event Time.
6	00000000 – 00100000	Only optional fields present are Cumulative Crank Revolutions and Last Crank Event Time.
7	00000000 – 01000000	Only optional fields present are Maximum Force Magnitude and Minimum Force Magnitude.
8	00000000 – 10000000	Only optional fields present are Maximum Torque Magnitude and Minimum Torque Magnitude.
9	00000001 – 00000000	Only optional fields present are Maximum Angle and Minimum Angle.
10	00000010 – 00000000	Only optional field present is Top Dead Spot.
11	00000100 – 00000000	Only optional field present is Bottom Dead Spot.

Test Pattern	Flags Field Value (bit15 ... bit0)	Pass Criteria
12	00001000 – 00000000	Only optional field present is Accumulated Energy.
13	00010000 – 00000000	No optional field present. Offset Compensation Indicator set to True.

Table 4.32: Receive Cycling Power Measurement Notifications from two Legacy CP Sensors

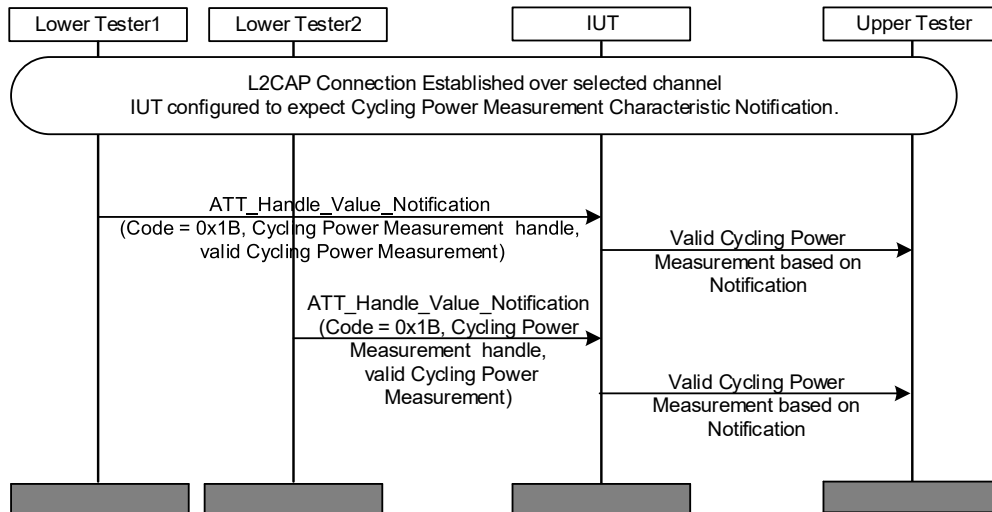

Figure 4.17: Receive Cycling Power Measurement Notifications from two Legacy CP Sensors MSC

- Expected Outcome

Pass verdict

The IUT is able to correctly parse the received Cycling Power Measurement values according to the pass criteria in the table above. The reported Cycling Power Measurement field values match the ones sent by the Lower Testers.

**CPP/COL/CPF/BV-42-C [Read Cycling Power Feature Characteristic with Bonding Enabled]**

- Test Purpose

Verify that, after the initial connection and bonding, the Collector IUT can read the Cycling Power Feature characteristic.

- Reference

[13] 4.4

- Initial Condition

- Establish an ATT Bearer connection between the Lower Tester and IUT as described in Section 4.2.1 if using an LE transport, or Section 4.2.2 if using a BR/EDR transport.
- The IUT is bonded with the Lower Tester.
- The Upper Tester knows the handle of the Cycling Power Feature characteristic contained in the Lower Tester.

- Test Procedure
  1. The Upper Tester commands the IUT to read the Cycling Power Feature characteristic from the Lower Tester.
  2. The IUT sends an ATT\_Read\_Request to the Lower Tester containing the handle specified by the Upper Tester.
  3. The Lower Tester receives the ATT\_Read\_Request and then sends an ATT\_Read\_Response to the IUT containing the value of the characteristic.
  4. The IUT receives the ATT\_Read\_Response and reports the value to the Upper Tester.

- Expected Outcome

Pass verdict

The IUT reads the Cycling Power Feature characteristic and reports its value to the Upper Tester.

Reserved for future use bit values are ignored.

### CPP/COL/CPF/BV-43-C [Enable Cycling Power Feature Characteristic for Indication or Read Feature Characteristic Upon Reconnection]

- Test Purpose

Verify that the Collector IUT can either enable the Cycling Power Feature characteristic for indication or read the Cycling Power Feature characteristic upon reconnection.

- Reference

[13] 4.4

- Initial Condition

- The handles of the Cycling Power Feature characteristic and Client Characteristic Configuration descriptor have been previously discovered by the Upper Tester during the test procedures in Section 4.3.1 or are known to the Upper Tester by other means.
- Establish an ATT Bearer connection between the Lower Tester and the IUT as described in Section 4.2.1 if using an LE transport or Section 4.2.2 if using a BR/EDR transport.
- The IUT is not paired and bonded with the Lower Tester.

- Test Procedure

1. The Upper Tester orders the IUT to initiate pairing and bonding.
2. The Upper Tester commands the IUT to perform either alternative 2A or 2B:

Alternative 2A (Configure the Cycling Power Feature characteristic for indication):

- 2A.1. The IUT configures the Cycling Power Feature characteristic for indication.

Or

Alternative 2B (Read the Cycling Power Feature characteristic upon reconnection):

2B.1. The Upper Tester commands the IUT to disconnect, and the IUT terminates the connection with the Lower Tester.

2B.2. The Upper Tester commands the IUT to reconnect to the Lower Tester.

2B.3. The IUT reads the Cycling Power Feature characteristic from the Lower Tester and reports the value to the Upper Tester.

- Expected Outcome

Pass verdict

In Step 1, the IUT successfully completes pairing and bonding.

In Step 2A.1, the IUT enables the Cycling Power Feature characteristic for indication.

In Step 2B.3, the IUT reads the Cycling Power Feature characteristic and reports its value to the Upper Tester.

Reserved for future use bit values are ignored.

## 4.6 Service Procedures – Set Cumulative Value

This test group contains test cases to verify compliant operation when the Cycling Power Control Point Set Cumulative Value procedure is used.

### CPP/COL/SPS/BV-01-C [Set Cumulative Value – Set to zero]

- Test Purpose

Verify that the Collector IUT can perform the Set Cumulative Value procedure to set a zero value.

- Reference

[3] 4.7.2.1

- Initial Condition

- Perform the preamble described in Section 4.2.3.
- The value of Cumulative Wheel Revolutions in the Lower Tester is set to a known non-zero value.

- Test Procedure

1. A connection is established between the IUT and Lower Tester using the Preamble defined in Section 4.2.4 if using an LE transport or 4.2.6 if using a BR/EDR transport.
2. The Lower Tester sends one or more notifications of the Cycling Power Measurement characteristic with the Cumulative Wheel Revolutions field set to a non-zero value.
3. The IUT writes the Set Cumulative Value Op Code (0x01) to the Cycling Power Control Point with a Parameter Value of 0x00000000.
4. The Lower Tester sends an indication of the Cycling Power Control Point characteristic with the Response Code Op Code (0x20) and a Parameter representing Request Op Code (0x01) followed by the Response Code for 'success' (0x01).
5. The IUT sends ATT\_Handle\_Value\_Confirmation to the Lower Tester.
6. The Lower Tester sends a notification of the Cycling Power Measurement characteristic with the Cumulative Wheel Revolutions field set to 0 (or close to 0).

- Expected Outcome

Pass verdict

The IUT receives one or more notifications of the Cycling Power Measurement characteristic with the Cumulative Wheel Revolutions field set to a non-zero value.

After setting the value to zero, the IUT receives the next notification of the Cycling Power Measurement characteristic containing the Cumulative Wheel Revolutions with the value of the Cumulative Wheel Revolutions field set to 0 (or slightly higher in case of movement).

### CPP/COL/SPS/BV-02-C [Set Cumulative Value - Set to non-zero]

- Test Purpose

Verify that the Collector IUT can perform the Set Cumulative Value procedure to set a non-zero value.

- Reference

[3] 4.7.2.1

- Initial Condition

- Perform the preamble described in Section 4.2.3.
- The value of Cumulative Wheel Revolutions in the Lower Tester is set to a known value.

- Test Procedure

1. A connection is established between the IUT and Lower Tester using the Preamble defined in Section 4.2.4 if using an LE transport or 4.2.6 if using a BR/EDR transport.
2. The Lower Tester sends one or more notifications of the Cycling Power Measurement characteristic with the Cumulative Wheel Revolutions field set to any value.
3. The IUT writes the Set Cumulative Value Op Code (0x01) to the Cycling Power Control Point with a Parameter Value that is different than the initial value (e.g., 0x0000FFFF).
4. The Lower Tester sends an indication of the Cycling Power Control Point characteristic with the Response Code Op Code (0x20) and a Parameter representing Request Op Code (0x01) followed by the Response Code for 'success' (0x01).
5. The IUT sends ATT\_Handle\_Value\_Confirmation to the Lower Tester.
6. The Lower Tester sends a notification of the Cycling Power Measurement characteristic with the Cumulative Wheel Revolutions field set to the specified value (or close to the specified value).

- Expected Outcome

Pass verdict

The IUT receives one or more notifications of the Cycling Power Measurement characteristic with the Cumulative Wheel Revolutions field set to the specified non-zero value.

After setting the value, the IUT receives the next notification of the Cycling Power Measurement characteristic containing the Cumulative Wheel Revolutions field with the value of the Cumulative Wheel Revolutions field set to the specified value (or slightly higher in case of movement).

## 4.7 Service Procedures – Handle CP Sensor Parameters

This test group contains test cases to verify compliant operation when the IUT uses the Cycling Power Control Point to handle internal CP Sensor parameters (e.g., Set or Request).

### 4.7.1 Cycling Power Control Point Procedures: Update and Set

- Test Purpose  
Verify that the Collector IUT can perform the Update and Set Cycling Power Control Point procedures.
- Reference  
[\[3\]](#) 4.7.2.2, 4.7.2.4, 4.7.2.6, 4.7.2.8, 4.7.2.10
- Initial Condition
  - Perform the preamble described in Section [4.2.3](#).
- Test Case Configuration

Test Case	Procedure (Op Code)	Parameter	Parameter Value
<a href="#">CPP/COL/SPP/BV-01-C</a> <a href="#">[Update Sensor Location]</a>	Update Sensor Location (0x02)	Sensor Location	Supported Location Value
<a href="#">CPP/COL/SPP/BV-03-C</a> <a href="#">[Set Crank Length]</a>	Set Crank Length (0x04)	Crank Length	Valid crank length value (Uint16) in millimeters with a resolution of 1/2 millimeter
<a href="#">CPP/COL/SPP/BV-05-C</a> <a href="#">[Set Chain Length]</a>	Set Chain Length (0x06)	Chain Length	Valid chain length value (Uint16) in millimeters with a resolution of 1 millimeter
<a href="#">CPP/COL/SPP/BV-07-C</a> <a href="#">[Set Chain Weight]</a>	Set Chain Weight (0x08)	Chain Weight	Valid chain weight value (Uint16) in grams with a resolution of 1 gram
<a href="#">CPP/COL/SPP/BV-09-C</a> <a href="#">[Set Span Length]</a>	Set Span Length (0x0A)	Span Length	Valid span length value (Uint16) in millimeters with a resolution of 1 millimeter

Table 4.33: Cycling Power Control Point Procedures: Update and Set test cases

- Test Procedure
  1. A connection is established between the IUT and Lower Tester using the Preamble defined in Section [4.2.4](#) if using an LE transport or Section [4.2.6](#) if using a BR/EDR transport.
  2. The IUT writes the Op Code from [Table 4.33](#) to the Cycling Power Control Point with the Parameter Value of this Control Point set to the value from [Table 4.33](#).
  3. The Lower Tester sends an indication of the Cycling Power Control Point characteristic with the Response Code Op Code (0x20) and a Parameter representing the Request Op Code from [Step 2](#) followed by the Response Code for 'success' (0x01).
  4. The IUT sends ATT\_Handle\_Value\_Confirmation to the Lower Tester.

- Expected Outcome

#### Pass verdict

The Parameter from [Table 4.33](#) is updated with the correct value.

The IUT receives the Request Op Code 'success'.



## 4.7.2 Cycling Power Control Point Procedures: Request

- Test Purpose
 

Verify that the Collector IUT can perform the Request Cycling Power Control Point procedures.
- Reference
 

[3] 4.7.2.3, 4.7.2.5, 4.7.2.7, 4.7.2.9, 4.7.2.11, 4.7.2.14, 4.7.2.15
- Initial Condition
  - Perform the preamble described in Section 4.2.3.
- Test Case Configuration

Test Case	Procedure (Op Code)	Response Value
CPP/COL/SPP/BV-02-C [Request Supported Sensor Locations]	Request Supported Sensor Location Op Code (0x03)	List of supported sensor locations
CPP/COL/SPP/BV-04-C [Request Crank Length]	Request Crank Length (0x05)	Value of the crank length (UInt16) in millimeters with a resolution of 1/2 millimeter
CPP/COL/SPP/BV-06-C [Request Chain Length]	Request Chain Length (0x07)	Value of the chain length (UInt16) in millimeters with a resolution of 1 millimeter
CPP/COL/SPP/BV-08-C [Request Chain Weight]	Request Chain Weight (0x09)	Value of the chain weight (UInt16) in grams with a resolution of 1 gram
CPP/COL/SPP/BV-10-C [Request Span Length]	Request Span Length (0x0B)	Value of the span length (UInt16) in millimeters with a resolution of 1 millimeter
CPP/COL/SPP/BV-11-C [Request Factory Calibration Date]	Request Factory Calibration Date (0x0F)	Factory calibration date (see Date Time characteristic format in [11])
CPP/COL/SPP/BV-12-C [Request Sampling Rate]	Request Sampling Rate (0x0E)	Value of the sampling rate (UInt8) in Hertz with a resolution of 1 Hertz

Table 4.34: Cycling Power Control Point Procedures: Request test cases

- Test Procedure
  1. A connection is established between the IUT and Lower Tester using the Preamble defined in Section 4.2.4 if using an LE transport or 4.2.6 if using a BR/EDR transport.
  2. The IUT writes the Op Code from Table 4.34 to the Cycling Power Control Point with no Parameter.
  3. The Lower Tester sends an indication of the Cycling Power Control Point characteristic with the Response Code Op Code (0x20) and a Parameter representing the Request Op Code from Step 2 followed by the Response Code for 'success' (0x01) and the Response Value from Table 4.34.
  4. The IUT sends ATT\_Handle\_Value\_Confirmation to the Lower Tester.
- Expected Outcome
 

Pass verdict

The IUT receives the Response Value from Table 4.34.

## 4.8 Service Procedure – Offset Compensation

### CPP/COL/SPO/BV-01-C [Start Offset Compensation – Force Based CP Sensor]

- Test Purpose

Verify that the Collector IUT can perform the Start Offset Compensation procedure and interpret correctly the Response Parameter from a Force-based CP Sensor.

- Reference

[3] 4.7.2.13

- Initial Condition

- Perform the preamble described in Section 4.2.3.

- Test Procedure

1. A connection is established between the IUT and Lower Tester using the Preamble defined in Section 4.2.4 if using an LE transport or 4.2.6 if using a BR/EDR transport.
2. The IUT writes the Start Offset Compensation Op Code (0x0C) to the Cycling Power Control Point with no Parameter.
3. The Lower Tester sends an indication of the Cycling Power Control Point characteristic with the Response Code Op Code (0x20) and a Parameter representing the Request Op Code (0x0C), the Response Code for 'success' (0x01) followed by the Response Parameter representing the value of the offset before the offset is compensated (SINT16) in Newtons with a resolution of 1 Newton.
4. The IUT sends ATT\_Handle\_Value\_Confirmation to the Lower Tester.

- Expected Outcome

Pass verdict

The IUT receives valid offset value and interprets the unit correctly, based on the Sensor Measurement Context bit of the Cycling Power Measurement context.

### CPP/COL/SPO/BV-02-C [Start Offset Compensation – Torque Based CP Sensor]

- Test Purpose

Verify that the Collector IUT can perform the Start Offset Compensation procedure and interpret correctly the Response Parameter from a Torque-based CP Sensor.

- Reference

[3] 4.7.2.13

- Initial Condition

- Perform the preamble described in Section 4.2.3.

- Test Procedure

1. A connection is established between the IUT and Lower Tester using the Preamble defined in Section 4.2.4 if using an LE transport or 4.2.6 if using a BR/EDR transport.
2. The IUT writes the Start Offset Compensation Op Code (0x0C) to the Cycling Power Control Point with no Parameter.
3. The Lower Tester sends an indication of the Cycling Power Control Point characteristic with the Response Code Op Code (0x20) and a Parameter representing the Request Op Code (0x0C),



the Response Code for 'success' (0x01) followed by the Response Parameter representing the value of the offset before the offset is compensated (SINT16) in Newton meters with a resolution of 1/32 Newton meter.

4. The IUT sends ATT\_Handle\_Value\_Confirmation to the Lower Tester.

- Expected Outcome

Pass verdict

The IUT receives valid offset value and interprets the unit correctly, based on the Sensor Measurement Context bit of the Cycling Power Measurement context.

## 4.9 Service Procedure – Mask Characteristic Content

### CPP/COL/SPM/BV-01-C [Mask Cycling Power Measurement Characteristic Content]

- Test Purpose

Verify that the Collector IUT can perform the Mask Cycling Power Measurement Characteristic Content procedure.

- Reference

[3] 4.7.2.13

- Initial Condition

- Perform the preamble described in Section 4.2.3.

- Test Procedure

1. A connection is established between the IUT and Lower Tester using the Preamble defined in Section 4.2.4 if using an LE transport or 4.2.6 if using a BR/EDR transport.
2. The IUT writes the Mask Cycling Power Measurement Characteristic Content Op Code (0x0D) to the Cycling Power Control Point with a Parameter Value set to a valid mask value (Uint16).
3. The Lower Tester sends an indication of the Cycling Power Control Point characteristic with the Response Code Op Code (0x20) and a Parameter representing Request Op Code (0x0D) followed by the Response Code for 'success' (0x01).
4. The IUT sends ATT\_Handle\_Value\_Confirmation to the Lower Tester.
5. The Lower Tester sends one or more ATT\_Handle\_Value\_Notifications of the Cycling Power Measurement characteristic with the masked fields not present.

- Expected Outcome

Pass verdict

The mask value is updated with the correct value.

The IUT receives the Request Op Code 'success'.

## 4.10 Service Procedure – Enhanced Offset Compensation

### CPP/COL/SPO/BV-03-C [Start Enhanced Offset Compensation – Force Based CP Sensor]

- Test Purpose

Verify that the Collector IUT can perform the Start Enhanced Offset Compensation procedure and interpret correctly the Response Parameter from a Force-based CP Sensor.



- Reference
  - [3] 4.7.2.16
- Initial Condition
  - Perform the preamble described in Section 4.2.3.
  - The IUT has read the Cycling Power Feature characteristic showing that the CP Sensor is Force Based.
- Test Procedure
  1. A connection is established between the IUT and Lower Tester using the Preamble defined in Section 4.2.4 if using an LE transport or 4.2.6 if using a BR/EDR transport.
  2. The IUT writes the Start Enhanced Offset Compensation Op Code (0x10) to the Cycling Power Control Point with no Parameter.
  3. The Lower Tester sends an indication of the Cycling Power Control Point characteristic with the Response Code Op Code (0x20) and a Parameter representing the Request Op Code (0x10), the Response Code for 'success' (0x01) followed by the Response Parameter representing the value of the offset before the offset is compensated (Sint16) in Newtons with a resolution of 1 Newton followed by a Uint16 value representing the manufacturer Company ID as given in the SIG assigned numbers (e.g., 0x003F for Bluetooth SIG), a Uint8 representing the number of octets (e.g., 0x03) of manufacturer specific data (e.g., Analog to Digital Conversion data), and the corresponding manufacturer specific data in the Response Parameter (e.g., 0x123456).
  4. The IUT sends ATT\_Handle\_Value\_Confirmation to the Lower Tester.
- Expected Outcome
  - Pass verdict
  - The IUT receives valid offset value and interprets the unit correctly, based on the Sensor Measurement Context bit of the Cycling Power Measurement context. The IUT may ignore the manufacturer specific data included in the Response Parameter.

### CPP/COL/SPO/BV-04-C [Start Enhanced Offset Compensation – Torque Based CP Sensor]

- Test Purpose
 

Verify that the Collector IUT can perform the Start Enhanced Offset Compensation procedure and interpret correctly the Response Parameter from a Torque-based CP Sensor.
- Reference
  - [3] 4.7.2.16
- Initial Condition
  - Perform the preamble described in Section 4.2.3.
  - The IUT has read the Cycling Power Feature characteristic showing that the CP Sensor is Torque Based.
- Test Procedure
  1. A connection is established between the IUT and Lower Tester using the Preamble defined in Section 4.2.4 if using an LE transport or 4.2.6 if using a BR/EDR transport.
  2. The IUT writes the Start Enhanced Offset Compensation Op Code (0x10) to the Cycling Power Control Point with no Parameter.



3. The Lower Tester sends an indication of the Cycling Power Control Point characteristic with the Response Code Op Code (0x20) and a Parameter representing the Request Op Code (0x10), the Response Code for 'success' (0x01) followed by the Response Parameter representing the value of the offset before the offset is compensated (SINT16) in Newton meters with a resolution of 1/32 Newton meter followed by a Uint16 value representing the manufacturer Company ID as given in the SIG assigned numbers (e.g., 0x003F for Bluetooth SIG), a Uint8 representing the number of octets (e.g., 0x03) of manufacturer specific data (e.g., Analog to Digital Conversion data), and the corresponding manufacturer specific data in the Response Parameter (e.g., 0x123456).
4. The IUT sends ATT\_Handle\_Value\_Confirmation to the Lower Tester.

- Expected Outcome

Pass verdict

The IUT receives valid offset value and interprets the unit correctly, based on the Sensor Measurement Context bit of the Cycling Power Measurement context. The IUT may ignore the manufacturer specific data included in the Response Parameter.

### CPP/COL/SPO/BI-01-C [Start Enhanced Offset Compensation – Incorrect Calibration Position]

- Test Purpose

Verify that the Collector IUT can perform the Start Enhanced Offset Compensation procedure and interpret correctly the Response Parameter when the CP Sensor is in an incorrect calibration position.

- Reference

[3] 4.7.2.16

- Initial Condition

- Perform the preamble described in Section 4.2.3.

- Test Procedure

1. A connection is established between the IUT and Lower Tester using the Preamble defined in Section 4.2.4 if using an LE transport or 4.2.6 if using a BR/EDR transport.
2. The IUT writes the Start Enhanced Offset Compensation Op Code (0x10) to the Cycling Power Control Point with no Parameter.
3. The Lower Tester sends an indication of the Cycling Power Control Point characteristic with the Response Code Op Code (0x20) and a Parameter representing the Request Op Code (0x10), the Response Code for 'operation failed' (0x04) followed by the Response Parameter value set to Incorrect Calibration Position (0x01).
4. The IUT sends ATT\_Handle\_Value\_Confirmation to the Lower Tester.

- Expected Outcome

Pass verdict

The IUT interprets the Response Code and the Response Parameter correctly.



## CPP/COL/SPO/BI-02-C [Start Enhanced Offset Compensation – Manufacturer Specific Error]

- Test Purpose

Verify that the Collector IUT can perform the Start Enhanced Offset Compensation procedure and interpret correctly the Response Parameter when the CP Sensor returns a Manufacturer Specific Error.

- Reference

[3] 4.7.2.16

- Initial Condition

- Perform the preamble described in Section 4.2.3.

- Test Procedure

1. A connection is established between the IUT and Lower Tester using the Preamble defined in Section 4.2.4 if using an LE transport or 4.2.6 if using a BR/EDR transport.
2. IUT writes the Start Enhanced Offset Compensation Op Code (0x10) to the Cycling Power Control Point with no Parameter.
3. The Lower Tester sends an indication of the Cycling Power Control Point characteristic with the Response Code Op Code (0x20) and a Parameter representing the Request Op Code (0x10), the Response Code for 'operation failed' (0x04) followed by the Response Parameter value set to Manufacturer Specific Error (0xFF) followed by a Uint16 value representing the manufacturer Company ID as given in the SIG assigned numbers (e.g., 0x003F for Bluetooth SIG), a Uint8 representing the number of octets (e.g., 0x03) of manufacturer specific data (e.g., Analog to Digital Conversion data), and the corresponding manufacturer specific data in the Response Parameter (e.g., 0x123456).
4. The IUT sends ATT\_Handle\_Value\_Confirmation to the Lower Tester.

- Expected Outcome

Pass verdict

The IUT interprets the Response Code and the Response Parameter correctly. The IUT may ignore the manufacturer specific data included in the Response Parameter.

## 4.11 Service Procedures – General Error Handling

This test group contains test cases to verify compliant operation when an error is caused by the Server side.

### 4.11.1 General Error Handling

- Test Purpose

Verify that the Collector IUT behaves appropriately when it receives an error handling Cycling Power Control Point Response Code.

- Reference

[3] 4.7.3

- Initial Condition

- Perform the preamble described in Section 4.2.3.



- Test Case Configuration

Test Case	Procedure (Op Code)	Parameter/Parameter Value	Response Code Value
<a href="#">CPP/COL/SPE/BI-01-C [Unsupported Op Code]</a>	Any Supported Op Code	Valid Parameter and Parameter Values if required by Op Code	Op Code not supported (0x02)
<a href="#">CPP/COL/SPE/BI-02-C [Invalid Parameter]</a>	Update Sensor Location (0x02)	Parameter: Sensor Location Parameter Value: Any Sensor Location Value	Invalid Parameter (0x03)
<a href="#">CPP/COL/SPE/BI-03-C [Operation Failed]</a>	Any Supported Op Code	Valid Parameter and Parameter Values if required by Op Code	Operation Failed (0x04)

Table 4.35: General Error Handling test cases

- Test Procedure

1. A connection is established between the IUT and Lower Tester using the Preamble defined in Section 4.2.4 if using an LE transport or 4.2.6 if using a BR/EDR transport.
2. The IUT writes the Op Code from Table 4.35 to the Cycling Power Control Point using the Parameter and Parameter Values from Table 4.35 for the Op Code.
3. The Lower Tester sends an indication of the Cycling Power Control Point characteristic with the Response Code Op Code (0x20) and a Parameter representing Request Op Code followed by the Response Code Value from Table 4.35.
4. The IUT considers the procedure to have failed.

- Expected Outcome

Pass verdict

The IUT returns to stable state and can process commands normally.

### CPP/COL/SPE/BI-04-C [Cycling Power Control Point Procedure Timeout]

- Test Purpose

Verify that if the Collector IUT does not receive a response to a Cycling Power Control Point Op Code, it will time out after the Attribute Transaction Timeout.

- Reference

[3] 4.7.4

- Initial Condition

- Perform the preamble described in Section 4.2.3.

- Test Procedure

1. A connection is established between the IUT and Lower Tester using the Preamble defined in Section 4.2.4 if using an LE transport or 4.2.6 if using a BR/EDR transport.
2. The IUT writes any of the supported Op Codes to the Cycling Power Control Point using an appropriate Parameter for the Op Code.
3. The Lower Tester does not send an indication of the Cycling Power Control Point characteristic for at least longer than the Attribute Protocol Timeout.
4. After the specified timeout the IUT sends a notification of Attribute Transaction Timeout to the Upper Tester and the IUT considers the procedure to have failed.



- Expected Outcome

Pass verdict

The IUT returns to a stable state and can process commands normally.

## 5 Test case mapping

The Test Case Mapping Table (TCMT) maps test cases to specific requirements in the ICS. The IUT is tested in all roles for which support is declared in the ICS document.

The columns for the TCMT are defined as follows:

**Item:** Contains a logical expression based on specific entries from the associated ICS document. Contains a logical expression (using the operators AND, OR, NOT as needed) based on specific entries from the applicable ICS document(s). The entries are in the form of y/x references, where y corresponds to the table number and x corresponds to the feature number as defined in the ICS document for Cycling Power Profile [4].

If a test case is mandatory within the respective layer, then the y/x reference is omitted.

**Feature:** A brief, informal description of the feature being tested.

**Test Case(s):** The applicable test case identifiers are required for Bluetooth Qualification if the corresponding y/x references defined in the Item column are supported. Further details about the function of the TCMT are elaborated in [1].

For the purpose and structure of the ICS/IXIT, refer to [1].

Item	Feature	Test Case(s)
CPP 7/1	Discover Cycling Power Service	CPP/COL/CGGIT/SER/BV-01-C
CPP 8/1	Discover Device Information Service and characteristics	CPP/COL/CPD/BV-15-C CPP/COL/CPD/BV-16-C CPP/COL/CGGIT/SER/BV-02-C
CPP 9/1	Discover Battery Service and characteristics	CPP/COL/CGGIT/SER/BV-03-C CPP/COL/CGGIT/CHA/BV-06-C
(CPP 2/2 AND NOT CPP 2/1) AND GATT 1a/4	Discover Cycling Power Service – Not Discoverable over BR/EDR	CPP/SEN/SGGIT/SDPNF/BV-01-C
CPP 7/2	Discover Cycling Power Feature Characteristic	CPP/COL/CGGIT/CHA/BV-01-C
CPP 11a/1	Characteristic GGIT – Cycling Power Feature indication	CPP/COL/CGGIT/ISFC/BV-01-C
CPP 11a/2 AND (CPP 13/3 OR CPP 13/6)	Read Cycling Power Feature characteristic – Bonding enabled	CPP/COL/CPF/BV-42-C
(CPP 11a/1 OR CPP 11a/2) AND (CPP 13/3 OR CPP 13/6)	Enable Cycling Power Feature characteristic for indication or read characteristic upon reconnection	CPP/COL/CPF/BV-43-C
CPP 7/3	Discover Cycling Power Measurement Characteristic	CPP/COL/CGGIT/CHA/BV-02-C
CPP 7/6	Discover Sensor Location Characteristic	CPP/COL/CGGIT/CHA/BV-03-C
CPP 7/7	Discover Cycling Power Control Point Characteristic	CPP/COL/CGGIT/CHA/BV-04-C
CPP 7/9	Discover Cycling Power Vector Characteristic	CPP/COL/CGGIT/CHA/BV-05-C

Item	Feature	Test Case(s)
CPP 3/2	Cycling Power Service UUID in AD in GAP Discoverable Mode	CPP/SEN/CPF/BV-01-C
CPP 3/3	Local Name in AD or Scan Response	CPP/SEN/CPF/BV-02-C
CPP 3/4	Appearance in AD or Scan Response	CPP/SEN/CPF/BV-03-C
CPP 11/1	Read Cycling Power Feature characteristic	CPP/COL/CPF/BI-01-C
CPP 11/2	Configure Cycling Power Measurement characteristic for notifications	CPP/COL/CPF/BV-05-C
CPP 11/3	Receive Cycling Power Measurement characteristic notifications	CPP/COL/CPF/BV-06-C CPP/COL/CPF/BI-02-C CPP/COL/CPF/BI-03-C
CPP 10/10	Calculates Accumulated Torque	CPP/COL/CPF/BV-07-C CPP/COL/CPF/BV-15-C
CPP 10/11	Calculates Instantaneous Speed	CPP/COL/CPF/BV-08-C CPP/COL/CPF/BV-14-C
CPP 10/11 AND CPP 13/3	Calculates Instantaneous Speed	CPP/COL/CPF/BV-12-C
CPP 10/12	Calculates Instantaneous Cadence	CPP/COL/CPF/BV-09-C CPP/COL/CPF/BV-10-C
CPP 10/12 AND CPP 13/3	Calculates Instantaneous Speed	CPP/COL/CPF/BV-13-C
CPP 10/13	Calculates Accumulated Energy	CPP/COL/CPF/BV-11-C
CPP 10/4	Calculates Total Instantaneous Power from a Distributed Power System	CPP/COL/CPF/BV-17-C
CPP 10/5	Calculates Power Balance from a Distributed Power System	CPP/COL/CPF/BV-18-C
CPP 11/5	Read Sensor Location characteristic	CPP/COL/CPF/BI-04-C
CPP 11/25	Configure Cycling Power Vector for Notification	CPP/COL/CPF/BV-20-C
CPP 11/26	Receive Cycling Power Vector Notifications	CPP/COL/CPF/BV-21-C CPP/COL/CPF/BI-05-C
CPP 10/12 AND CPP 10/22	Cycling Power Vector – Calculates Instantaneous Cadence	CPP/COL/CPF/BV-22-C CPP/COL/CPF/BV-23-C
CPP 2/2 AND CPP 13/4 AND CPP 11/27	Verify Bond Status on Reconnection – LE	CPP/COL/CPF/BV-24-C
CPP 2/1 AND CPP 4/1 AND CPP 11/27	Verify Bond Status on Reconnection – BR/EDR	CPP/COL/CPF/BV-25-C
CPP 11/4	Configure Cycling Power Measurement for broadcast	CPP/COL/CPF/BV-26-C
CPP 15/1	Receive Cycling Power Measurement Broadcast	CPP/OBS/CPF/BV-27-C CPP/OBS/CPF/BI-06-C CPP/OBS/CPF/BI-07-C
CPP 15/1 AND CPP 15/5	Cycling Power Measurement Broadcast – Calculates Accumulated Torque	CPP/OBS/CPF/BV-28-C

Item	Feature	Test Case(s)
CPP 15/1 AND CPP 15/6	Cycling Power Measurement Broadcast – Calculates Instantaneous Speed	CPP/OBS/CPF/BV-29-C
CPP 15/1 AND CPP 15/7	Cycling Power Measurement Broadcast - Calculates Instantaneous Cadence	CPP/OBS/CPF/BV-30-C CPP/OBS/CPF/BV-31-C
CPP 15/1 AND CPP 15/8	Cycling Power Measurement Broadcast – Calculates Accumulated Energy	CPP/OBS/CPF/BV-32-C
CPP 15/2	Receive Cycling Power Measurement Broadcast from a Distributed Power System	CPP/OBS/CPF/BV-33-C
CPP 15/2 AND CPP 15/3	Calculates Total Instantaneous Power from a Distributed Power System	CPP/OBS/CPF/BV-34-C
CPP 15/2 AND CPP 15/4	Calculates Power Balance from a Distributed Power System	CPP/OBS/CPF/BV-35-C
CPP 10/6	Set Cumulative Value – Set to zero	CPP/COL/SPS/BV-01-C
CPP 10/7	Set Cumulative Value – Set to non- zero	CPP/COL/SPS/BV-02-C
CPP 10/8	Update Sensor Location	CPP/COL/SPP/BV-01-C
CPP 10/9	Request Supported Sensor Locations	CPP/COL/SPP/BV-02-C
CPP 10/14	Set Crank Length	CPP/COL/SPP/BV-03-C
CPP 10/15 AND CPP 11/13	Request Crank Length	CPP/COL/SPP/BV-04-C
CPP 10/16	Set Chain Length	CPP/COL/SPP/BV-05-C
CPP 10/17 AND CPP 11/15	Request Chain Length	CPP/COL/SPP/BV-06-C
CPP 10/18	Set Chain Weight	CPP/COL/SPP/BV-07-C
CPP 10/19 AND CPP 11/17	Request Chain Weight	CPP/COL/SPP/BV-08-C
CPP 10/20	Set Span Length	CPP/COL/SPP/BV-09-C
CPP 10/21 AND CPP 11/19	Request Span Length	CPP/COL/SPP/BV-10-C
CPP 10/26 AND CPP 11/22	Request Factory Calibration Date	CPP/COL/SPP/BV-11-C
CPP 10/25 AND CPP 11/22	Request Sampling Rate	CPP/COL/SPP/BV-12-C
CPP 10/23 AND CPP 11/20	Start Offset Compensation	CPP/COL/SPO/BV-01-C CPP/COL/SPO/BV-02-C
CPP 10/24 AND CPP 11/21	Mask Characteristic Content	CPP/COL/SPM/BV-01-C
CPP 11/6 AND CPP 11/7	Write to SC Control Point characteristic and Receive SC Control Point characteristic indications	CPP/COL/SPE/BI-01-C CPP/COL/SPE/BI-02-C CPP/COL/SPE/BI-03-C
CPP 11/24	SC Control Point Characteristic – Procedure Time Out	CPP/COL/SPE/BI-04-C

Item	Feature	Test Case(s)
CPP 10/3	Receive Cycling Power Measurement characteristic notifications from a Distributed Power System	CPP/COL/CPF/BV-36-C CPP/COL/CPF/BV-37-C CPP/COL/CPF/BV-38-C
CPP 10/3 AND CPP 10/4	Receive Cycling Power Measurement characteristic notifications from two sensors (calculate Total Instantaneous Power)	CPP/COL/CPF/BV-39-C CPP/COL/CPF/BV-41-C
CPP 10/3 AND CPP 10/5	Calculates Power Balance from two sensors which can be used in a distributed power system	CPP/COL/CPF/BV-40-C
CPP 11/28	Enhanced Offset Compensation	CPP/COL/SPO/BV-03-C CPP/COL/SPO/BV-04-C CPP/COL/SPO/BI-01-C CPP/COL/SPO/BI-02-C

Table 5.1: Test case mapping

## 6 Revision history and acknowledgments

### Revision History

Publication Number	Revision Number	Date	Comments
0	1.0.0	2013-04-30	Release for publication.
	1.0.1r1	2013-05-16	TSE 5175: Updated TCMT mapping for TP/CPF/CO/BV-16-I to "CPP 10/3 and CPP 11/3"
1	1.0.1	2013-07-02	Prepare for Publication
	1.02r1	2013-08-16	TCRL 2013-2 TSE 5240: Updated reserved bits value from "0xA4" to "0xC4" in TP/CPF/CO/BI-05-I. TSE 5296: Updated first sentence of the test procedure in TP/CPD/CO/BV-16-I to add, "and a disconnection may occur between the two tests" for clarification.
2	1.0.2	2013-12-03	Prepare for Publication
	1.0.3r00	2014-04-11	TSE 5452: Updated TCMT Mapping for TP/CPD/CO/BV-01-I.
	1.0.3r01	2014-06-01	Added Pass/Fail Verdict Conventions according to applicable test specification template.
3	1.0.3	2014-07-07	TCRL 2014-1 Publication
	1.04r01	2014-09-05	TSE 5891: Updated the values in the test procedure of TP/CPF/CO/BV-22-I. TSE 5870: Updated the value for "Right Pedal" to 0x80 in TP/CPF/CO/BV-16-I, TP/CPF/CO/BV-17-I and TP/CPF/CO/BV-18-I.
	1.0.4r02	2014-10-06	TSE 5958: Updated TCMT mapping for TP/CPF/CO/BV-24-I.
4	1.0.4	2014-12-05	Prepare for TCRL 2014-2 publication
	1.0.5r00	2015-05-10	TSE 6126: Revised accumulated torque values in TP/CPF/CO/BV-07-I TSE 6379: Revised mapping in TCMT for TP/CPF/OB/BV-28-I through 35-I
5	1.0.5	2015-07-14	Prepared for TCRL 2015-1 publication
	1.1.0r00	2015-11-02	Added tests cases for Cycling Power Profile v1.1
	1.1.0r01	2015-11-02	Updated Test Case Mapping Table to match added table in the ICS Removed test case [Receive Cycling Power Measurement Notifications from a CP Sensor – Unknown Distributed System Configuration] since the team agrees that no specific behavior can be described as of now in the specification for this situation.
	1.1.0r02	2015-11-04	Fixed Test Case Mapping Table; Fixed numbering formatting issue in section 4.3.13 Fixed test procedure and pass criteria in section 4.4.48.

Publication Number	Revision Number	Date	Comments
	1.1.0r03	2015-11-11	Removed one remaining 'Fail verdict' in section 4.4.18.
	1.1.0r04	2016-01-05	Converted to current document template.
	1.1.0r05	2016-02-15	Minor editorial changes (formatting, spelling and punctuation). Fixed Test Case Mapping table Fixed reference in "Initial Condition" of test cases in section 4.3 Updated Test Case Mapping Table.
	1.1.0r06	2016-04-04	Addressed BTI comments; fixed cross-reference; changed Test Case Mapping Table to simplify triggering of tests cases specific to V1.0 or to V1.1.
	1.1.0r07	2016-04-04	Updated TCMT to match removal of table 12 in the ICS
	1.1.0r08	2016-04-07	Updated section 3.2 with test indicating that some tests cases require 2 Lower Testers Updated figure 4.19 with two Lower Testers.
	1.1.0r09	2016-04-08	Fixed indent on test case section heading
	1.1.0	2016-04-19	Approved by BTI
	1.1.0	2016-05-03	Specification version 1.1 adopted by the Bluetooth SIG BoD. TSE 6936: Updated Initial Condition of test case TP/CPF/CO/BV-20-I.
6	1.1.0	2016-05-09	Prepared for publication
	1.1.1r00	2016-05-20	Converted to new Test Case ID conventions as defined in TSTO v4.1.
7	1.1.1	2016-07-14	Prepared for TCRL 2016-1 publication.
	1.1.2r00	2016-02-17	TSE 7497: Updated mapping for CPP/COL/CPF/BV-22-I and CPP/COL/CPF/BV-23-I to CPP 10/12 AND CPP 10/22. TSE 8445: Corrected values in CPP/COL/CPF/BV-15-I Accumulated Torque column for rows 3-7 to Table 4.11: Receive Cycling Power Measurement Notifications – Accumulated Torque Value Decreases.
	1.1.2r01	2017-03-20	TSE 8428: Updated Test Case Mapping Table for CPP/COL/CPF/BV-12-I and CPP/COL/CPF/BV-13-I. Removed CPP/COL/CPF/BV-12-I from CPP 10/11 and added it to new mapping CPP 10/11 AND CPP 13/3. Removed CPP/COL/CPF/BV-13-I from CPP 10/12 and added it to new mapping CPP 10/12 AND CPP 13/3. TSE 8444: Corrected values in Accumulated Energy Value column for rows 3-5 to Table 4.7 in CPP/COL/CPF/BV-11-I.
	1.1.2r02	2017-04-20	TSE 8518: Updated table 4.12 for CPP/COL/CPF/BV-17-I by modifying row 1 and 3, and adding row 4. Updated Table 4.28 for CPP/COL/CPF/BV-39-I by modifying row 1 and 3, and adding row 4.

Publication Number	Revision Number	Date	Comments
			TSE 8519: Updated Table 4.13 for CPP/COL/CPF/BV-18-I by modifying row 1 and 3, and adding row 4. Updated Table 4.29 for CPP/COL/CPF/BV-40-I by modifying row 1 and 3, and adding row 4.
8	1.1.2	2017-06-26	Approved by BTI. Prepared for TCRL 2017-1 publication.
	1.1.3r00	2017-08-21	TSE 9248: Updated Initial Condition text for CPP/COL/CPF/BV-38-I.
9	1.1.3	2017-11-28	Approved by BTI. Prepared for TCRL 2017-2 publication.
	p10r00–r05	2022-03-14 – 2022-05-18	<p>TSE 17255 (rating 2): Converted tests to GGIT: the new GGIT TCIDs are: CPP/COL/CGGIT/SER/BV-01-C – -03-C, CPP/COL/CGGIT/CHA/BV-01-C – -06-C, and CPP/SEN/SGGIT/SDPNF/BV-01-C, and the deleted TCIDs are CPP/COL/CPD/BV-01-I – -04-I, -06-I – -14-I, -17-I, and -18-I; CPP/COL/CPF/BV-04-I, and -19-I; and CPP/SEN/CPD/BV-05-I. Also added a “Test database requirements” section, updated the “Test groups” section, and added the GGIT material to the TCID conventions section. Updated initial condition for CPP/COL/CPD/BV-15-I to cite a GGIT test case. Updated TCMT accordingly.</p> <p>TSE 18436 (rating 1): Removed direct references to GATT test cases in CPP/COL/CPD/BV-15-I and -16-I, and in the Preambles sections for ATT Bearer on LE Transport and ATT Bearer on BR/EDR Transport.</p> <p>TSE 18579 (rating 1): Fixed typo in TCMT entry for CPP/OBS/CPF/BV-33-I.</p> <p>TSE 18667 (rating 1): To address a deprecation issue, deleted CPP/COL/CPF/BV-16-I and updated the TCMT accordingly, and moved the TCMT entry for CPP/COL/CPF/BV-39-I.</p> <p>TSE 18710 (rating 1): Editorials to align the document with the latest TS template in anticipation of a future .Z release.</p> <p>Performed template-related formatting fixes. Assigned publication number 9 to previous v1.1.3 and aligned copyright page with v2 of the DNMD. Consistency check update.</p>
10	p10	2022-06-28	Approved by BTI on 2022-05-31. Prepared for TCRL 2022-1 publication.
	p11r00	2022-08-18	TSE 19019 (rating 2): Updated properties for the CPP/COL/CGGIT/CHA/BV-02-C GGIT test.
11	p11	2023-02-07	Approved by BTI on 2022-12-28. Prepared for TCRL 2022-2 publication.
	p12r00–r05	2023-08-30 – 2023-12-18	TSE 17222 (rating 4): Per E16588, added new test group ISFC and three new test cases: CPP/COL/CGGIT/ISFC/BV-01-C, CPP/COL/CPF/BV-42-C and -43-C. Updated the TCMT accordingly. Updated the Properties value for

Publication Number	Revision Number	Date	Comments
			<p>CPP/COL/CGGIT/CHA/BV-01-C. Updated the references list and the TCID conventions table.</p> <p>TSE 18588 (rating 1): Per E15782, made Appropriate Language updates to align with CPP v1.1.1 adoption. Updated the Bonded Devices preamble purpose and preamble procedure and the test purpose, test procedure, and expected outcome for CPP/COL/CPF/BV-25-C. Added the Appropriate Language Mapping Tables document to the references list.</p> <p>TSE 23265 (rating 1): Converted the following TCs to -C tests: CPP/COL/CPD/BV-15-C and -16-C; CPP/COL/CPF/BI-01-C – -05-C; CPP/COL/CPF/BV-05-C – -15-C, -17-C, -18-C, -20-C – -26-C, and -36-C – -41-C; CPP/COL/SPM/BV-01-C; CPP/COL/SPO/BI-01-C and -02-C; CPP/COL/SPO/BV-01-C – -04-C; CPP/COL/SPP/BV-01-C – -12-C; CPP/COL/SPS/BV-01-C and -02-C; CPP/OBS/CPF/BI-06-C and -07-C; CPP/OBS/CPF/BV-27-C – -35-C; CPP/SEN/CPD/BV-05-C; and CPP/SEN/CPF/BV-01-C – -03-C. Updated the TCMT accordingly.</p> <p>Editorials to align the document with the latest TS template.</p>
12	p12	2024-07-01	Approved by BTI on 2024-04-21. Prepared for TCRL 2024-1 publication.
	p13r00	2024-11-05	TSE 24019 (rating 2): Converted the following individual test cases to the table-driven format: CPP/COL/SPP/BV-01-C to -12-C and CPP/COL/SPE/BI-01-C to -03-C.
13	p13	2025-02-18	Approved by BTI on 2024-12-23. Prepared for TCRL 2025-1 publication.
	p14r00	2025-07-17	TSE 27514 (rating 2): Removed reference to GAP 0/3 in the TCMT entry for CPP/SEN/SGGIT/SDPNF/BV-01-C.
14	p14	2025-11-04	Approved by BTI on 2025-10-02. Prepared for TCRL pkg101 publication.

### Acknowledgments

Name	Company
Dejan Berec	Bluetooth SIG, Inc.
Jawid Mirani	Bluetooth SIG, Inc.
Bob Hughes	Intel
Leif-Alexandre Aschehoug	Nordic Semiconductor
Guillaume Schatz	Polar